

REVUE TECHNIQUE

A700I



HS700ATV-4 (C)

FOREWORD

Brief introduction to maintenance handbook of HS700ATV-4

The handbook is edited by Technical Center of Chongqing Huansong Science And Technology Industrial Co.,Ltd, and is supplied to dealers and technicians as document of technique. Mainly, the handbook gives methods to check, maintain and repair four wheel all-terrain vehicles (ATV), and supplies some relevant technique and performance data. Some techniques and method inside may be used to check, maintain and repair other models of ATV, although it is mainly for HS700ATV-4.

Please read the handbook through and fully understand it; otherwise, any improper repairing and amounting would bring you problems, and accident may occur in your use.

Proper use and maintenance can guarantee ATV being driven safely, reduce its malfunction, and help the vehicle remain its best performance.

The standards, performances and specifications mentioned in interpretation are based on the sample in design, and they are subject to changes according to the product's improvement without prior notice.

First version , December,2014

Published by Chongqing Huansong Science And Technology Industrial Co.,Ltd

Chongqing Huansong Science And Technology Industrial Co.,Ltd holds the copy right.

No publishing and reprinting without permission.

CONTENT

CHAPTER 1 GENERAL INFORMATION

GENERAL INFORMATION	1
WARNING, CAUTIONS AND NOTES	1
DESCRIPTION	2
IDENTIFICATION CODE	3
Frame No.	3
Engine No.	3
SAFETY	4
Handling gasoline safely.....	4
Cleaning parts.....	5
Warning labels.....	5
SERIAL NUMBERS	6
FASTENERS	6
Torque specifications	6
Self-locking fasteners.....	6
Washers.....	7
Cotter pins.....	7
Snap rings and E-clips	7
SHOP SUPPLIES	8
Lubricants and Fluids.....	8
Engine oils.....	8
Greases.....	9
Brake fluid.....	9
Coolant.....	9
Cleaners, Degreasers and solvents	10
Gasket sealant.....	10
Gasket remover	10
Thread locking compound.....	10
BASIC TOOLS	11
Screwdrivers.....	11

Wrenches	12
Adjustable wrenches	12
Socket wrenches, ratchets and handles	13
Impact drivers	14
Allen wrenches.....	14
Torque wrenches.....	14
Torque adapters	15
Pliers.....	16
Snap ring pliers.....	16
Hammers	16
Ignition grounding tool.....	17
PRECISION MEASURING TOOLS	17
Feeler gauge	18
Calipers.....	18
Micrometers.....	18
Adjustment	19
Care	20
Metric micrometer.....	20
Standard inch micrometer.....	21
Telescoping and small bore gauges.....	22
Dial Indicator.....	22
Compression gauge.....	23
Multimeter.....	23
Clip-on ammeter.....	23
Magneto puller.....	24
ELECTRICAL SYSTEM FUNDAMENTALS.....	24
Voltage	24
Resistance.....	24
Amperage.....	24
BASIC SERVICE METHODS.....	25
Removing frozen fasteners.....	26
Removing broken fasteners	27
Repairing damaged threads	27
Stud Removal/Installation	27

Removing hoses	28
Bearings.....	28
Removal.....	28
Installation.....	29
Interference fit	30
Seal replacement.....	31
STORAGE.....	32
Storage area selection.....	32
Preparing the motorcycle for storage	32
Returning the ATV to service.....	33
TROUBLESHOOTING.....	33
ENGINE PRINCIPLES AND OPERATING REQUIREMENTS.....	34
STARTING THE ENGINE	34
Engine is cold	35
Engine is warm.....	35
Starting the engine after a fall or after the engine stalls.....	35
Flooded engine.....	35
ENGINE WILL NOT START	36
Identifying the problem	36
Spark test.....	37
Starter does not turn over or turns over slowly	38
POOR ENGINE PERFORMANCE.....	38
Engine starts slowly or difficultly.....	38
Engine backfires, cuts out or misfires during acceleration.....	39
Engine backfires on deceleration.....	39
Poor fuel mileage.....	39
Engine will not idle or idles roughly	39
Low engine power.....	40
Poor idle or low speed performance.....	41
Poor high speed performance	41
FUEL SYSTEM.....	42
Rich mixture.....	42
Lean mixture.....	42
ENGINE.....	43

Engine smoke.....	43
Black smoke.....	43
Blue smoke.....	43
White smoke or steam.....	43
Low engine compression.....	43
High engine compression	44
Engine overheating (cooling system)	44
Engine overheating (engine).....	44
Ignition advance angle too large.....	45
Detonation.....	45
Power loss	45
engine noises.....	45
ENGLNE LUBRICATION.....	46
HIGH OIL CONSUMPTION OR EXCESSIVE.....	46
Exhaust smoke.....	46
Low oil pressure	46
High oil pressure	46
No oil pressure.....	47
Oil level too low.....	47
Oil contamination.....	47
CYLINDER LEAK DOWN TEST.....	47
ELECTRICAL TESTING.....	50
Preliminary checks and precautions.....	50
Intermittent problems.....	50
Electrical component replacement.....	51
Test equipment.....	52
Ammeter.....	52
Self-powered test light.....	52
Ohmmeter.....	52
Jumper wire.....	53
TEST PROCEDURES.....	54
Voltage test.....	54
Voltage drop test.....	54
Peak voltage test.....	55

Continuity test.....	55
Testing for a short with a self-powered test light or ohmmeter.....	55
Testing for a short with a test light or voltmeter.....	56
BRAKE SYSTEM.....	56
Soft or spongy brake lever or pedal.....	56
Brake drag.....	57
Hard brake lever or pedal operation.....	58
Brake Grabs.....	58
Brake squeal or chatter	58
Leaking brake caliper	59
Leaking master cylinder.....	59

CHAPTER 2 SPECIFICATIONS

HOW TO USE CONVERSION TABLE OF UNIT.....	60
How to use conversion table.....	60
Definition of unit	60
GEBERAR SPECIFICATIONS.....	61
ENGINE SPECIFICATIONS.....	64
CHASSIS SPECIFICATIONS.....	70
ELECTRICAL SPECIFICATIONS.....	72
TIGHTENING TORQUES	74
Engine tightening torques.....	74
Chassis tightening torques.....	77
GENERAL TIGHTENING TORQUE SPECIFICATIONS	79
LUBRICATION PIONTS AND LUBRICANT TYPES.....	80
Engine.....	80
Chassis.....	81
HYDROGRAPHIC CHART.....	82
LUBRICATION OIL WAY.....	83

CHAPTER 3 MAINTENCE AND ADJUSTMENT OF THE ATV

MAINTENANCE SCHEDULE	84
ENGINE	
Adjusting the valve clearance.....	86
Checking the spark plug.....	88
Checking the ignition timing.....	89
Measuring the compression pressure.....	90
Checking the engine oil level.....	91
Changing the engine oil	92
CHASSIS	
Cleaning the air filter.....	95
Checking the coolant level	96
Changing the coolant.....	97
Checking the coolant temperature warning light	100
Checking the v-belt.....	101
Cleaning the spark arrester	101
Adjusting the brake pedal.....	102
Checking the brake fluid level	103
Checking the front brake pads.....	104
Checking the rear brake pads.....	104
Checking the brake hoses and brake pipes	105
Bleeding the hydraulic brake system	105
Adjusting the select lever shift rod	107
Adjusting the brake light switch	107
Checking the final gear oil level	108
Changing the final gear oil.....	108
Checking the differential gear oil.....	109
Changing the differential gear oil.....	109
Checking the constant velocity joint dust boots.....	110
Checking the steering system.....	111
Adjusting the toe-in	111
Adjusting the front shock absorbers.....	113
Adjusting the rear shock absorbers.....	113
Checking the tires	114
Checking the wheels.....	115

Checking and lubricating the cables	116
ELECTRICAL	
Checking and charging the battery.....	117
Checking the fuses.....	122
Adjusting the headlight beam	124
Changing the headlight bulb	124
Changing the tail/brake light bulb	125

CHAPTER 4 ENGINE

ENGINE NOTE.....	126
ENGINE REMOVAL.....	127
CYLINDER HEAD.....	130
VALVE SWING ARM COMP & VALVE.....	136
CAMSHAFT CHAIN.....	138
VALVES AND VALVE SPRINGS	143
CYLINDER AND PISTON.....	149
ENGINE COOLING FAN AND A.C. MAGNETO	153
BALANCER GEARS AND OIL PUMP GEARS.....	157
PRIMARY AND SECONDARY SHEAVES	
Primary and secondary sheaves.....	160
Primary sheave.....	161
Secondary sheave.....	162
CLUTCH.....	167
CLUTCH HOUSING.....	168
CRANKCASE STARTER MOTORAND OIL FILTER	171
Crankcase	172
Crankcase bearings.....	175
CRANKSHAFT AND OIL PUMP	
Crankshaft and oil pump	179
Oil pump.....	180

TRANSMISSION

Transmission.....	183
Drive axle assembly.....	184

MIDDLE GEAR

Middle gear.....	188
Middle drive shaft.....	189

CHAPTER 5 CHASSIS

MALFUNCTION INSPECTION.....	193
------------------------------------	------------

STEERING OPERATION SYSTEM.....	196
---------------------------------------	------------

The steering stem part.....	196
The steering handle and cable.....	198
The left handle bar.....	199

BRAKE SYSTEM.....	207
--------------------------	------------

Disk brake components	208
Front brake caliper.....	212
Rear brake caliper.....	220

FOOTREST ASSEMBLY	229
--------------------------------	------------

WHEEL AND TYRE PARTS	231
-----------------------------------	------------

Front wheels.....	231
Rear wheels.....	232
Front and rear wheel rim (different model).....	233

TRANSMISSION SYSTEM	238
----------------------------------	------------

Front bridge.....	238
Rear bridge.....	248

REVERSE MECHANISM PARTS	254
--------------------------------------	------------

SUSPENSION.....	258
------------------------	------------

Front Suspension and arm	258
Rear suspension	264
Rear arm shaft.....	265

COOLING SYSTEM.....	270
----------------------------	------------

Radiator	270
Water pump.....	274
SEAT	279
FUEL TANK	281
Fuel tank cover parts	281
Fuel tank parts	283

CHAPTER 6 ELECTRICAL COMPONENTS

ELECTRICAL SYSTEM MALFUNCTION INSPECTION	286
ELECTRICAL COMPONENTS	287
Checking the switch.....	289
Checking the switch continuity	290
Checking the bulbs and bulb sockets	291
IGNITION SYSTEM	291
Circuit diagram.....	291
Troubleshooting.....	292
ELECTRIC STARTING SYSTEM	295
Circuit diagram.....	295
Troubleshooting.....	296
STARTER MOTOR	298
CHARGING SYSTEM	298
Circuit diagram.....	298
Troubleshooting.....	299
LIGHTING SYSTEM	300
Circuit diagram.....	300
Troubleshooting.....	301
Checking the lighting system.....	302
SIGNALING SYSTEM	303
Circuit diagram	303
Troubleshooting	304
Checking the signal system.....	305

COOLING SYSTEM	312
Circuit diagram	312
Troubleshooting.....	313
2WD/4WD SELECTING SYSTEM	315
Circuit diagram.....	315
Troubleshooting.....	316

CHAPTER 7 ENGINE MANAGEMENT SYSTEM

INTRODUCTION

Ems (engine management system)	317
Typical components of EMS.....	317
Layout of EMS components.....	318

COMPONENTS OF EMS

Electronic control unit	319
Multec 3.5 injectors	320
Throttle body assembly(with stepper motor)	324
Engine coolant temperature sensor	326
Intake air pressure and temperature sensor	327
Oxygen sensor	327
Ignition coil.....	327
Fuel pump module.....	331

EMS FAULT DIAGNOSIS

EME fault diagnosis	337
Fault code list.....	337

CHAPTER 8 TROUBLESHOOTING

STARTING FAILURE/HARD STARTING	339
Fuel system	339
Electrical system	339

Compression system	340
POOR IDLE SPEED PERFORMANCE	340
Poor idle speed performance.....	340
POOR MEDIUM AND HIGH-SPEED PERFORMANCE	341
Poor medium and high-speed performance.....	341
FAULTY GEAR SHIFTING.....	341
Shift lever does not move	341
Jumps out of gear.....	341
ENGINE OVERHEATING.....	342
Overheating.....	342
FAULTY BRAKE.....	342
Poor braking effect.....	342
SHOCK ABSORBER MALFUNCTION.....	343
Loss of damping function.....	343
UNSTABLE HANDLING.....	343
Unstable handling.....	343
LIGHTING SYSTEM.....	343
Head light is out of work.....	343
Bulb burnt out.....	344
Error display of meter.....	344

CHAPTER 9 WIRING DIAGRAM

WIRING DIAGRAM.....	345
WIRING ECU DIAGRAM.....	346
IGNITION SYSTEM CIRCUIT DIAGRAM.....	347
CHARGING SYSTEM CIRCUIT DIAGRAM.....	348
ELECTRIC STARTING SYSTEM CIRCUIT DIAGRAM.....	349
LIGHTING SYSTEM CIRCUIT DIAGRAM.....	350
SIGNALING SYSTEM CIRCUIT DIAGRAM.....	351
COOLING SYSTEM CIRCUIT DIAGRAM.....	352
2WD/4WD SELECTION SYSTEM CIRCUIT DIAGRAM.....	353

GENERAL INFORMATION

GENERAL INFORMATION

The text provides complete information on maintenance, tune-up repair and overhaul, Hundreds of photographs and illustrations created during the complete disassembly of four wheel all-terrain vehicles (ATV) guide the reader through every job, All procedures are in step-by-step format and designed for the reader who may be working on the ATV for the first time.

WARNINGS, CAUTIONS AND NOTES

The terms **WARNING**, **CAUTION** and **NOTE** have specific meaning in this manual.

WARNING: *emphasizes areas where injury or even death could result from negligence.*

Mechanical damage may also occur. WARNINGS are to be taken seriously

CAUTION: emphasizes areas where equipment damage could result. Disregarding a **CAUTION** could cause permanent mechanical damage. though injury is unlikely.

NOTE: provides additional information to make a step or procedure easier or clearer. Disregarding a **NOTE** could cause inconvenience. but would not cause equipment damage or injury.

GENERAL INFORMATION

DESCRIPTION

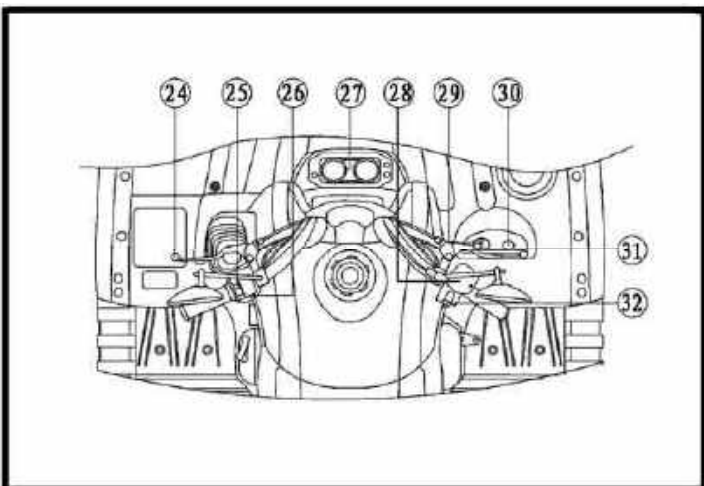
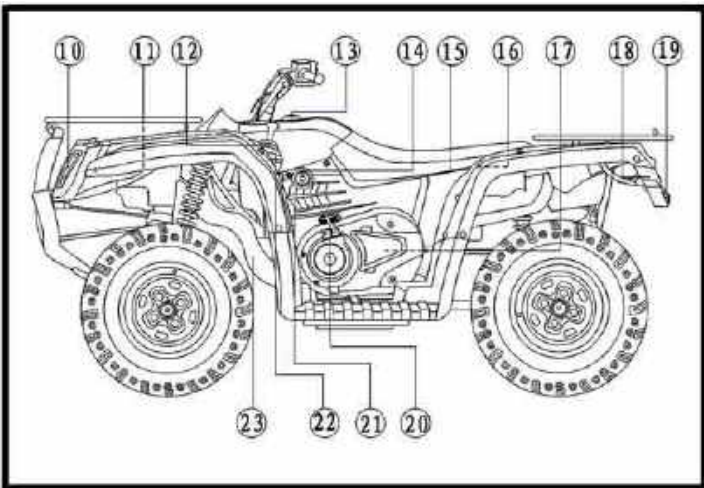
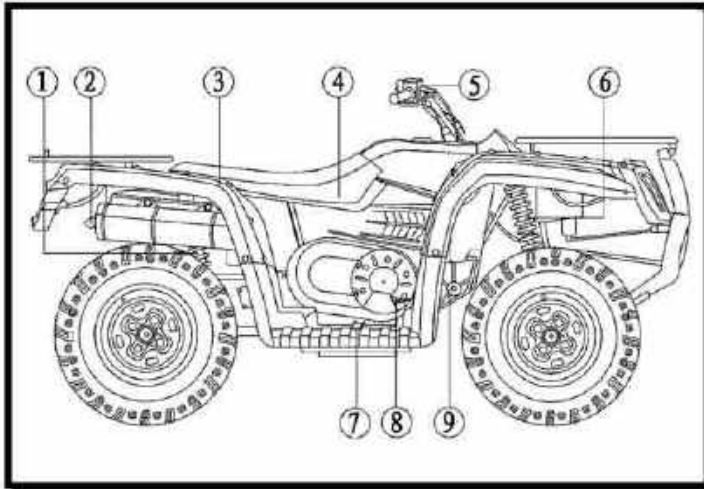

1. Rear shock absorber assembly
Adjusting ring
2. Spark arrester
3. Storage compartment and tool kit
4. Air filter case
5. Front brake fluid reservoir
6. Front shock absorber spring
preload Adjusting ring
7. V-belt case driver plug
8. Brake pedal
9. Rear brake fluid reservoir
10. Headlights
11. Radiator cap
12. Drive select lever
13. Fuel tank cap
14. Fuel cock
15. Battery
16. Fuses
17. Engine oil dipstick
18. Tail/brake lights
19. Recoil starter
20. Coolant reservoir
21. Drive select lever box check hose
22. V-belt cooling duct check hose
23. Rear brake lever
24. Left handlebar switches
25. Starter (choke)
26. Multi-function meter unit
27. Right handlebar switches
28. Main switch
29. Auxiliary DC jack
30. Front brake lever
31. Throttle lever

NOTE:

The vehicle you have purchased may differ slightly from those in the figures of this manual.

GENERAL INFORMATION

IDENTIFICATION CODE

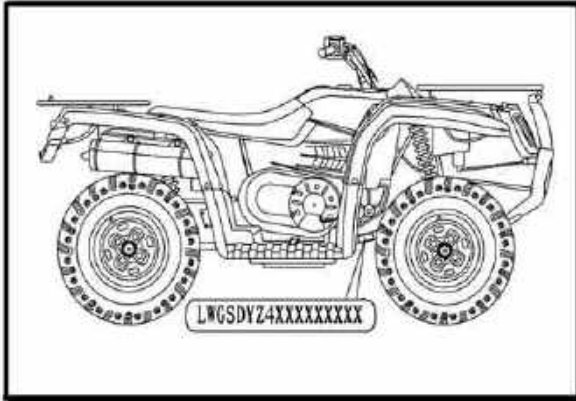

Frame No.

Frame No. is carved in the lower right side of Figure.

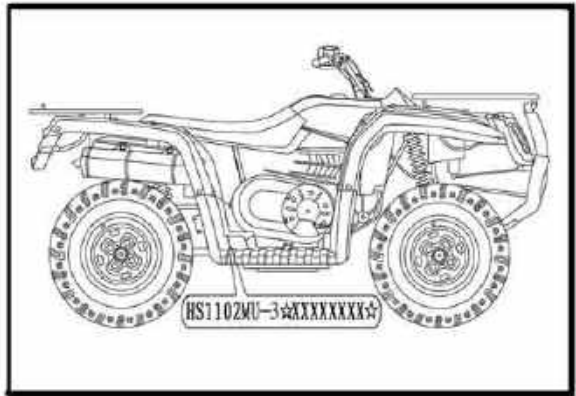

Engine No.

Engine NO. Is carved on the right side of the engine, Figure.

GENERAL INFORMATION

SAFETY

Professional mechanics can work for years and never sustain a serious injury or mishap. Follow these guidelines and practice common sense to safely service the utility terrain vehicles

1. Do not operate the utility terrain vehicles in an enclosed area. The exhaust gasses contain carbon monoxide, an odorless, colorless and tasteless poisonous gas. Carbon monoxide levels build quickly in small enclosed areas and can cause unconsciousness and death in a short time. Make sure to properly ventilate the work area or operate the ATV side.
2. Never use gasoline or any extremely flammable liquid to clean parts. Refer to *cleaning parts and handling Gasoline Safely* in this section.
3. Never smoke or use a torch in the vicinity of flammable liquids, such as gasoline or cleaning solvent.
4. If welding or brazing on the ATV, the fuel tank to a safe distance at least 50ft.(15m) away.
5. Use the correct type and size of tools to avoid damaging fasteners.
6. Keep tools clean and in good condition. Replace or repair worn or damaged equipment.
7. When loosening a tight fastener, be guided by what would happen if the tool slips.
8. When replacing fasteners, make sure the new fasteners are the same size and strength as the original ones.
9. Keep the work area clean and organized.
10. Wear eye protection anytime the safety of the eyes is in question. This includes procedures that involve drilling, grinding, hammering, compressed air and chemicals.
11. Wear the correct clothing for the job. Tie up or cover long hair so it does not get caught in moving equipment.
12. Do not carry sharp tools in clothing pockets.
13. Always have an approved fire extinguisher available. Make sure it is rated for gasoline (Class B) and electrical (Class C) fires.
14. Do not use compressed air to clean clothes, the ATV or the work area. Debris may be blown into the eyes or skin. Never direct compressed air at anyone. Do not allow children to use or play with any compressed air equipment.
15. When using compressed air to dry rotating parts, hold the part so it does not rotate. Do not allow the force of the air to spin the part. The air jet is capable of rotating parts at extreme speed. The part may disintegrate or become damaged, causing serious injury.
16. Do not inhale the dust created by brake pad and clutch wear. These particles may contain asbestos. In addition, some types of insulating materials and gaskets may contain asbestos. Inhaling asbestos particles is hazardous to one's health.
17. Never work on the ATV while someone is working under it.

Handling Gasoline Safely

Gasoline is a volatile flammable liquid and is one of the most dangerous items in the shop. Because gasoline is used so often, many people forget it is hazardous. Only use gasoline as fuel for gasoline internal combustion engines. Keep in mind when working on the machine, gasoline is always present in the fuel tank, fuel line and throttle. To avoid a disastrous accident when working

GENERAL INFORMATION

around the fuel system, carefully observe the following precautions:

1. Never use gasoline to clean parts. Refer to Cleaning Parts in this section.
2. When working of the fuel system, work outside or in a well-ventilated area.
3. Do not add fuel to the fuel tank or service the fuel system while the ATV is near open flames, sparks or where someone is smoking .Gasoline vapor is heavier than air, it collects in low areas and is more easily ignited than liquid gasoline.
4. Allow the engine to cool completely before working on any fuel system component.
5. Do not store gasoline in glass containers. If the glass breaks, a serious explosion of fire may occur.
6. Immediately wipe up spilled gasoline with rags. Store the rags in a metal container with a lid until they can be properly disposed of, or place them outside in a safe place for the fuel to evaporate.
7. Do not pour water onto a gasoline fire. Water spreads the fire and makes it more difficult to put out. Use a class B, BC or ABC fire extinguisher which are dedicated to extinguish the gasoline fire.
8. Always turn off the engine before refueling. Do not spill fuel onto the engine or exhaust system. Do not overfill the fuel tank. Leave an air space at the top of the tank to allow room for the fuel to expand due to temperature fluctuations.

Cleaning Parts

Cleaning parts is one of the more tedious and difficult service jobs performed in the home garage. Many types of chemical cleaners and solvents are available for shop use. Most are poisonous and extremely flammable. To prevent chemical exposure, vapor buildup, fire and serious injury, observe each product warning label and note the following:

1. Read and observe the entire product label before using any chemical. Always know what type of chemical is being used and whether it is poisonous and/or flammable.
2. Do not use more than one type of cleaning solvent at a time. If mixing chemicals is required, measure the proper amounts according to the manufacturer.
3. Work in a well-ventilated area.
4. Wear chemical-resistant gloves.
5. Wear safety glasses.
6. Wear a vapor respirator if the instructions call for it.
7. Wash hands and arms thoroughly after cleaning parts.
8. Keep chemical products away from children and pets.
9. Thoroughly clean all oil, grease and cleaner residue from any part that must be heated.
10. Use a nylon brush when cleaning parts. Metal brushes may cause a spark.
11. When using a parts washer, only use the solvent recommended by the manufacturer. Make sure the parts washer is equipped with a metal lid that will lower in case of fire.

Warning Labels

Most manufacturers attach information and warning labels to the ATV. These labels contain instructions that are important to personal safety when operating, servicing, transporting and storing

GENERAL INFORMATION

the ATV. Refer to the owner's manual for the description and location of labels. Order replacement labels from the dealers or manufacturer if they are missing or damaged.

SERIAL NUMBERS

Serial and identification numbers are stamped on various locations on the frame, engine and throttle body. Record these numbers in the Quick Reference Data section in the front of the manual. Have these numbers available when ordering parts.

FASTENERS

Proper fastener selection and installation is important to ensure the motorcycle operates as designed and can be serviced efficiently. The choice of original equipment fasteners is not arrived at by chance. Make sure replacement fasteners meet all the same requirements as the originals

Many screws, bolts and studs are combined with nuts to secure particular components. to indicate the size of a nut. Manufacturers specify the internal diameter and the thread pitch

The measurement across two flats on a nut or bolt indicates the wrench size

WARNING

Do not install fasteners with a strength classification lower than what was originally installed by the manufacturer doing so may cause equipment failure and or damage

Torque Specifications

The material used in the manufacturing of the ATV may be subjected to uneven stresses if the fasteners of the various subassemblies are not installed and tightened correctly. Fasteners that are improperly installed or work loose can cause extensive damage. it is essential to use an accurate torque wrench as described in this chapter

Self-Locking Fasteners

Several types of bolts, screws and nuts incorporate a system that creates interference between the two fasteners. Interference is achieved in various ways. The most common types are the nylon insert nut and a dry adhesive coating on the threads of a bolt.

Self-locking fasteners offer greater holding strength than standard fasteners, which improves their resistance to vibration. All self-locking fasteners cannot be reused. The materials used to form the lock become distorted after the initial installation and removal. Discard and replace self-locking fasteners after removing them. Do not replace self-locking fasteners with standard fasteners.

GENERAL INFORMATION

Washers

The two basic types of washers are flat washers and lock washers. Flat washers are simple discs with a hole to fit a screw or bolt. Lock washers are used to prevent a fastener from working loose. Washers can be used as spacers and seals. Or can help distribute fastener load and prevent the fastener from damaging the component

As with fasteners. When replacing washers make sure the replacement washers are of the same design and quality

Cotter Pins

A cotter pin is a split metal pin inserted into a hole or slot to prevent a fastener from loosening. In certain applications, such as the rear axle on an ATV or motorcycle, the fastener must be secured in this way. For these applications. A cotter pin and castellated (slotted) nut is used.

To use a cotter pin, first make sure the diameter is correct for the hole in the fastener. After correctly tightening the fastener and aligning the holes, insert the cotter pin through the hole and bend the ends over the fastener, Unless instructed to do so, never loosen a tightened fastener to align the holes. If the holes do not align. Tighten the fastener enough to achieve alignment

Cotter pins are available in various diameters and lengths. Measure the length from the bottom of the head to the tip of the shortest pin

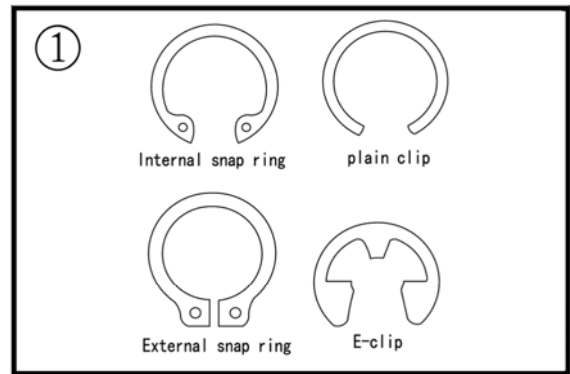

Snap Rings and E-clips

Snap rings (**Figure 1**) are circular-shaped metal retaining clips. They secure parts in place on parts such as shafts. External type snap rings are used to retain items on shafts. Internal type snap rings secure parts within housing bores. In some applications. in addition to securing the component(s). snap rings of varying thicknesses also determine endplay. These are usually called selective snap rings.

The two basic types of snap rings are machined and stamped snap rings. Machined snap rings (**Figure 2**) can be installed in either direction. Because both faces have sharp edges. Stamped snap rings (**Figure 3**) are manufactured with a sharp and a round edge. When installing a stamped snap ring in a thrust application, install the sharp edge

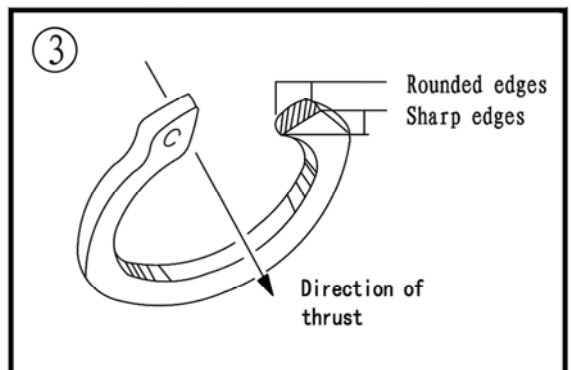
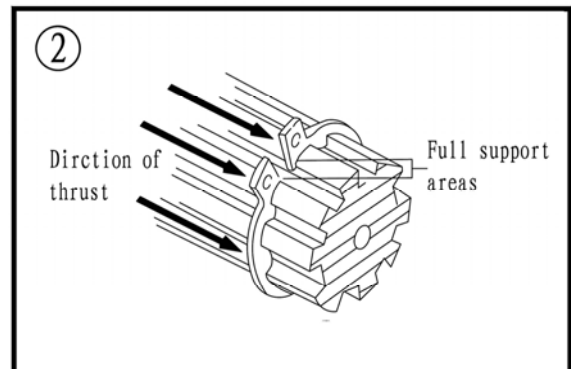

GENERAL INFORMATION

facing away from the part producing the thrust.

E-clips are used when it is not practical to use a snap ring. Remove E-clips with a flat blade screwdriver by prying between the shaft and E-clip. To install an E-clip. Center it over the shaft groove and push or tap it into place

Observe the following when installing snap rings:

1. Remove and install snap rings with snap rings pliers. Refer to *Basic Tools* in this chapter
2. In some applications, it may be necessary to replace snap rings after removing them
3. Compress or expand snap rings only enough to install them. If overly expanded, Lose their retaining ability
4. After installing a snap ring. Make sure it seats completely
5. Wear eye protection when removing and installing snap rings

SHOP SUPPLIES

Lubricants and Fluids

Periodic lubrication help ensure a long service life for any type of equipment. Using the correct type of lubricant is as important as performing the lubrication service. Although in an emergency the wrong type is better than not using one, The following section describes the types of lubricants most often required. Make sure to follow the manufacturer's recommendations for lubricant types

Engine oils

Engine oil for four-stroke the ATV engine use is classified by two standards: the American Petroleum Institute (API) service classification. The Society of Automotive Engineers (SAE) viscosity rating Standard classification

The API and SAE information is on all oil container labels. Two letters indicate the API service classification. The number or sequence of numbers and letter (10W-40SG for example) is the oil's viscosity rating. The API service classification and the SAE viscosity index are not indications of oil quality.

The APL service classification standards, The first letter in the classification S indicates that the oil is for gasoline engines. The second letter indicates the standard the oil satisfies . The classifications are: MA (high friction applications) and MB(low frication applications).

NOTE

Refer to Engine Oil and Filter in Chapter Three for further information on API, SAE classifications.

Always use an oil with a classification recommended by the manufacturer, Using an oil with a different classification can cause engine damage.

Viscosity is an indication of the oil's thickness. Thin oils have a lower number while thick oil have a higher number. Engine oils fall into the 5-to50-weight range for single-grade oils.

GENERAL INFORMATION

Most manufactures recommend multi-grade oil. These oils perform efficiently across a wide range of operating conditions. Multi-grade oils are identified by a W after the first number, which indicates the low-temperature viscosity.

Engine oils are most commonly mineral (petroleum) based, but synthetic and semi-synthetic types are used more frequently. When selecting engine oil, follow the manufacturer's recommendation for type, classification and viscosity.

Greases

Grease is lubricating oil with thickening agents added to it. The National Lubricating Grease Institute (NLGI) grades grease. Grades range from No.000 to No.6, with No.6 being the thickest. Typical multipurpose grease is NLGI No.2. For specific applications, manufacturers may recommend water-resistant type grease or one with an additive such as molybdenum disulfide (MoS₂).

Brake fluid

Brake fluid is the hydraulic fluid used to transmit hydraulic pressure (force) to the wheel brakes. Brake fluid is classified by the Department of Transportation (DOT). Current designations for brake fluid are DOT 3, DOT 4 and DOT 5, this classification appears on the fluid container.

Each type of brake fluid has its own definite characteristics. Do not intermix different types of brake fluid as this may cause brake system failure. DOT 5 brake fluid is silicone based. DOT 5 is not compatible with other brake fluids may cause brake system failure. When adding brake fluid, only use the fluid recommended by the manufacturer.

Brake fluid will damage any plastic, painted or plated surface it contacts. Use extreme care when working with brake fluid and remove any spills immediately with soap and water.

Hydraulic brake systems require clean and moisture free brake fluid. Never reuse brake fluid. Keep containers and reservoirs properly sealed.

WARNING

Never put a mineral-based (Petroleum) oil into the brake system. Mineral oil causes rubber parts in the system to causing complete brake failure.

Coolant

Coolant is a mixture of water and antifreeze used to dissipate engine heat. Ethylene glycol is the most common form of antifreeze. Check the ATV Manufacturer's recommendations when selecting antifreeze. Most require one specifically designed for aluminum engines. There types of antifreeze have additives that inhibit corrosion.

Only mix antifreeze with distilled water. Impurities in tap water may damage internal cooling system passages.

GENERAL INFORMATION

Cleaners, Degreasers and Solvents

Many chemicals are available to remove oil, grease and other residue from the ATV. Before using cleaning solvents, consider how they will be used and disposed of, particularly if they are not water-soluble. Local ordinances may types of cleaning chemicals. Refer to Safer in this chapter.

Use brake parts cleaner to brake system components. Brake parts cleaner leaves no residue. Use electrical contact cleaner is a powerful solvent used to remove fuel deposits and varnish from fuel system components. Use this cleaner carefully, as it may damage finishes.

Most solvents are designed to be used with a parts washing cabinet for individual component cleaning. For safety, use only nonflammable or high flash point solvents.

Gasket Sealant

Sealant is used in combination with a gasket or seal. In other applications, such as between crankcase halves, only a sealant is used. Follow the manufacturer's recommendation when using a sealant. Use extreme care when choosing a sealant different sealant based on its resistance to heat, various fluids and its sealing capabilities.

Gasket Remover

Aerosol gaskets remover can help remove stubborn gasket. This product can speed up the removal process and prevent damage to the mating surface that may be caused by using a scraping tool. Most of these types of products are very caustic. Follow the gasket remover manufacturer's instructions for use.

Thread locking Compound

A thread locking compound is a fluid applied to the threads of fasteners. After tightening the fastener, the fluid dries and becomes a solid filler between the threads. This makes it difficult for the fastener to work loose from vibration or hear expansion and contraction. Some thread locking compound sparingly. Excess fluid can run into adjoining parts.

CAUTION

Thread locking compounds are anaerobic and will stress, crack and attack most plastics. Use caution when using these products in areas where there are plastic components.

Thread locking compounds are available in a wide range of compounds for various strength, temperature and repair applications. Follow the manufacturer's recommendations regarding compound selection.

GENERAL INFORMATION

BASIC TOOLS

Most of the procedures in this manual can be carried out with basic hand tools and test equipment familiar to the home mechanic. Always use the correct tools for the job. Keep tools organized and clean. Store them in a tool chest with related tools organized together.

Quality tools are essential. The best are constructed of high-strength alloy steel. These tools are light, easy to use and resistant to wear. Their working surface is devoid of sharp edges and carefully polished. They have an easy-to-clean finish and are comfortable to use. Quality tools are a good investment.

Some of the procedures in this manual specify special tools. In many cases the tools is illustrated in use. Those with a large tool kit may be able to replacement. However, in some cases, the specialized equipment or expertise may make it impractical for the home mechanic to attempt the procedure. When necessary, such operations are recommended to have a dealership or specialist perform the task. It may be less expensive to have a professional perform these jobs, especially when considering the cost of equipment.

When purchasing tools to perform the procedures covered in this manual, consider the tool's potential frequency of use. If a tool kit is just now being started. Consider purchasing a basic tool set from a quality tool combinations and offer substantial savings when complicated, specialized tools can be added.

Screwdrivers

Screwdrivers of various lengths and types are mandatory for the simplest tool kit. The two basic types are the slotted tip (flat blade) and the Phillips tip. These are available in sets that often include an assortment of tip size and shaft lengths.

As with all tools, use a screwdriver designed for the job. Make sure the size of the fastener. Use them only for driving screws. Never use a screwdriver for prying or chiseling metal. Repair or replace worn or damaged screwdrivers. A worn tip may damage the fastener, making it difficult to remove.

Phillips-head screws are often damaged by incorrectly fitting screwdrivers. Quality Phillips screwdrivers are manufactured with their crosshead tip machined to Phillips Screw Company specifications. Poor quality or damaged Phillips screwdrivers can back out (cam out) and round over the screw head. In addition. Weak or soft screw materials can make removal difficult.

The best type of screwdriver to use on Phillips screw is the ACR Phillips II screwdriver, patented by the horizontal anti-cam out ribs found on the driving faces or flutes of the screwdriver's tip (**figure 4**). ACR Phillips II screwdrivers were designed as part of a manufacturing drive system to be used with ACR Phillips II screws, but they work of tool companies offer ACR Phillips II screwdrivers in different Tip size and interchangeable bits to fit screwdriver bit holders.

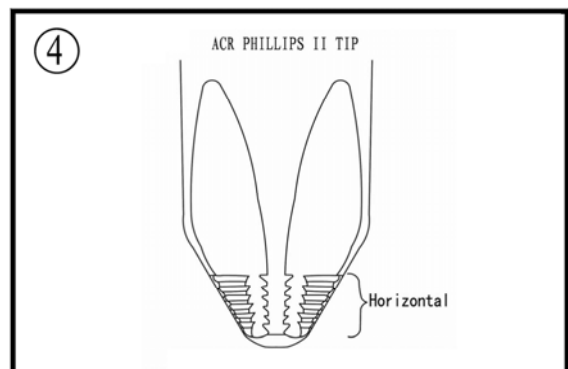

GENERAL INFORMATION

NOTE

Another way to prevent cam out and to increase the grip of a Phillips screwdriver is to apply valve grinding compound or permute screw & socket Gripper onto the screwdriver tip. After loosening/tightening the screw, clean the screw recess to prevent engine oil contamination.

Wrenches

Open-end, box-end and combination wrenches (figure 5) are available in a variety of types and sizes.

The number stamped on the wrench refers to the distance of the fastener head.

The box-end wrench is an excellent tool because it grips the fastener on all sides. This reduces the chance of the tool slipping. The box-end wrench is designed with either a 6 or 12-point opening. For stubborn or damaged fasteners, the 6-point provides superior holding because it contacts the fastener across a wider area at all six edges. For general use, the 12-point works well. It allows the wrench to be removed and reinstalled without moving the handle over such a wide area.

An open-end wrench is fast and works best in areas with limited overhead access. It contacts the fastener at only two points and is subject to slipping if under heavy force, or if the tool or fastener is worn. A box-end wrench is preferred in most instances, especially when braking loose and applying the final tightness to a fastener.

An open-end wrench is fast and works best in areas with limited overhead access. It contacts the fastener at only two points and is subject to slipping if under heavy force, or if the tool or fastener is worn. A box-end wrench is preferred in most instances, especially when braking loose and applying the final tightness to a fastener.

The combination wrench has a box-end on one end and an open-end on one end and an open-end on the other. This combination makes it a convenient tool.

Adjustable wrenches

An adjustable wrench or Crescent wrench (Figure 6) can fit nearly any nut or bolt head that has clear access around its entire perimeter. An adjustable wrench is best used as a backup wrench to keep a large nut or bolt from turning while the other end is being loosened or tightened with a box-end or socket wrench.

Adjustable wrenches contact the fastener at only two points, which makes them more subject to slipping off the fastener. Because one jaw is adjustable and may become loose, this shortcoming is aggravated.

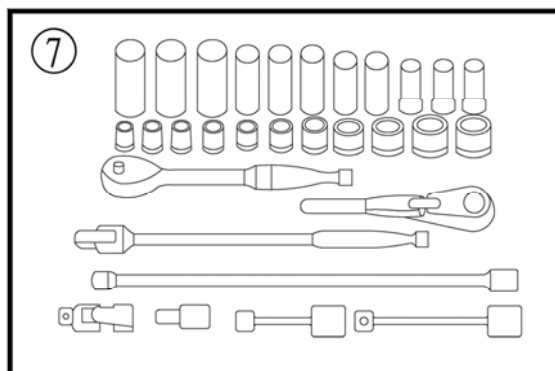
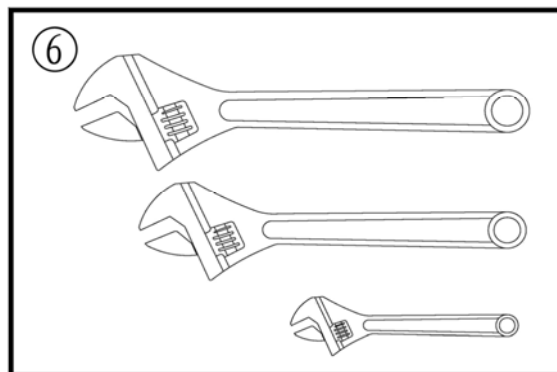
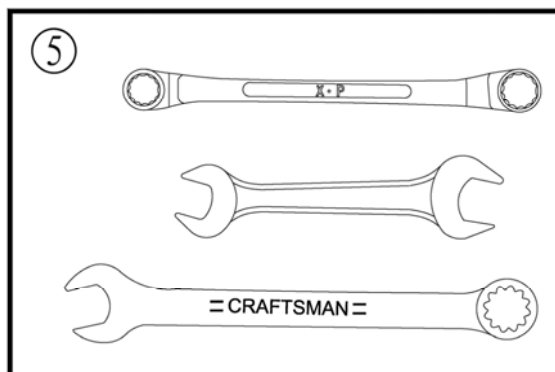

GENERAL INFORMATION

Make certain the solid jaw is the one transmitting the force.

Socket Wrenches, Ratchets and Handles

Sockets that attach to a ratchet handle (**Figure 7**) are available with 6-point or 12-point openings (**Figure 8**) and different drive sizes. The drive size indicates the size of the square hole that accepts the ratchet handle. The number stamped on the socket is the size of the work area and must match the fastener head

As with wrenches, a 6-point provides superior-holding ability. While a 12-point socket needs to be moved only half as far to reposition it on the fastener

Sockets are designated for either hand or impact use. Impact sockets are made of thicker material for more durability. Compare the size and wall thickness of a 19-mm hand socket (A, **Figure 9**) and the 19-mm impact socket (B). Use impact sockets when using an impact driver or air tools. Use hand sockets with hand-driven attachments

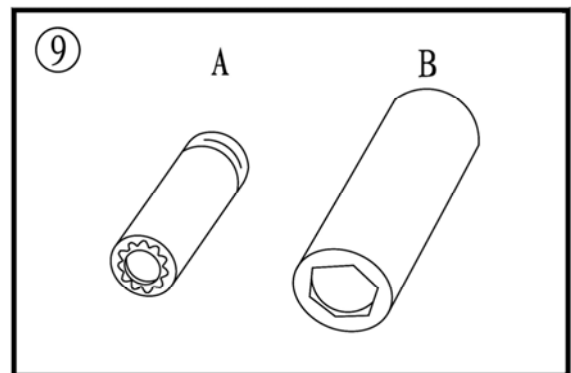
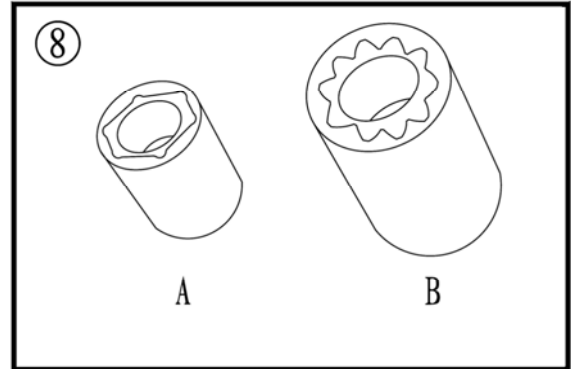

WARNING

Do not use hand sockets with air or impact tools because they may shatter and cause injury. Always wear eye protection when using impact or air tools

Various handles are available for sockets. Use the speed handle for fast operation. Flexible ratchet heads in varying length allow the socket to be turned with varying force and at odd angles. Extension bars allow the socket setup to reach difficult areas. The ratchet is the most versatile. It allows the user to install or remove the nut without removing the socket

Sockets combined with any number of drivers make them undoubtedly the fastest, safest and most convenient tool for fastener removal and installation

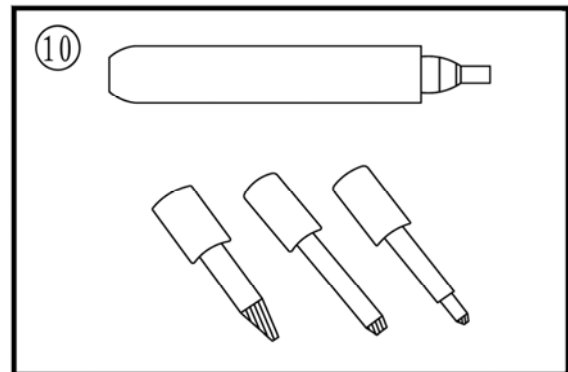

GENERAL INFORMATION

Impact Drivers

An impact driver provides extra force for removing fasteners by converting the impact of a hammer into a turning motion. This makes it possible to remove stubborn fasteners without damaging them. Impact drivers and interchangeable bits (**Figure 10**) are available from most tool suppliers. When using a socket with an impact driver. Make sure the socket is designed for impact use. Refer to *Socket Wrenches. Ratchets and handles* in this section.

WARNING

Do not use hand sockets with air or impact tools because they may shatter and cause injury. Always wear eye protection when using impact or air tools

Allen Wrenches

Use Allen or setscrew wrenches (**Figure 11**) on fasteners with hexagonal recesses in the fastener head. These wrenches are available in L-shaped bar. Socket and T-handle types. A metric set is required when working on most motorcycles. Allen bolts are sometimes called socket bolts.

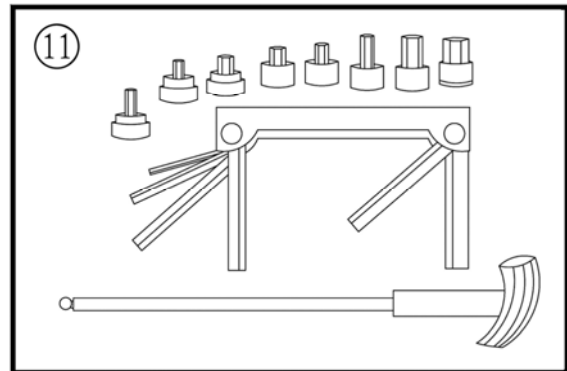

Torque Wrenches

Use a torque wrench with a socket, torque adapter or similar extension to tighten a fastener to a measured torque. Torque wrenches come in several drive sizes (1/4, 3/8, 1/2 and 3/4) and have various methods of reading the torque value. The drive size indicates the size of the square drive that accepts the socket, adapter or extension. Common methods of reading the torque value are the deflecting beam, the dial indicator and the audible click (**Figure 12**).

When choosing a torque wrench, consider the torque range, drive size and accuracy. The torque specifications in this manual provide an indication of the range required.

A torque wrench is a precision tool that must be properly cared for to remain accurate. Store torque wrenches in cases or separate padded drawers within a toolbox. Please refer to the followed manufacturer's instructions for their care and calibration.

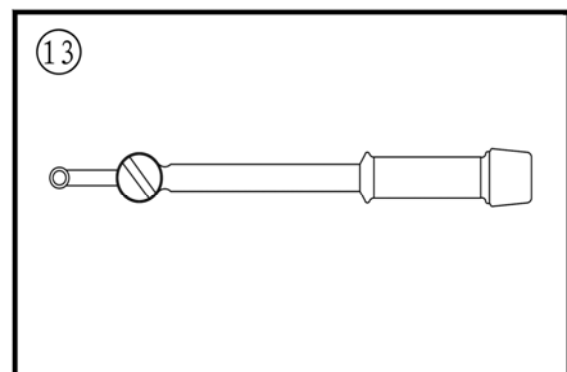
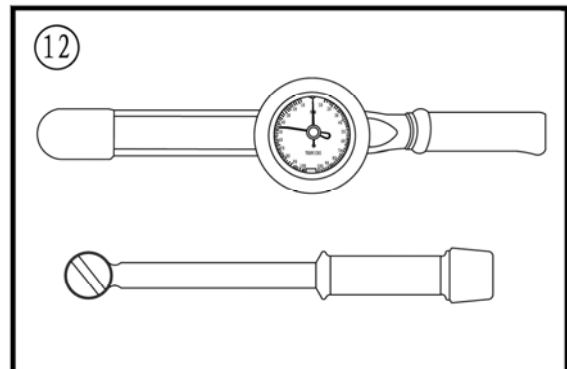

Torque Adapters

Torque adapters or extensions extend or reduce the reach of a torque wrench. The torque adapter shown in (Figure 13) is used to tighten a fastener that cannot be reached because of the size of the torque wrench head, drive, and socket. If a torque adapter changes the effective lever length (Figure 14), the torque reading on the wrench will not equal the actual torque applied to the fastener. It is necessary to recalibrate the torque setting on the wrench to compensate for the change of lever length. When using a torque adapter at a right angle to the drive head, calibration is not required, because the effective length has not changed.

To recalculate a torque reading when using a torque adapter, use the following formula and refer to Figure 14:

$$TW = \frac{TA \times L}{L + A}$$

TW is the torque setting or dial reading on the wrench.

TA is the torque specification and the actual amount of torque that is applied to the fastener.

A is the amount that the adapter increases (or in some cases reduces) the effective lever length as measured along the centerline of the torque wrench.

L is the lever length of the wrench as measured from the center of the drive to the center of the grip.

The effective length is the sum of *L* and *A*.

Example:

TA=20 ft.-lb.

A=3in.

L=14in.

$$TW = \frac{20 \times 14}{14 + 3} = \frac{280}{17} = 16.5 \text{ ft. - lb.}$$

In this example, the torque wrench would be set to the recalculated torque value (*TW* = 16.5 ft. -lb.). When using a beam-type wrench, tighten the fastener until the pointer aligns with 16.5 ft. -lb. In

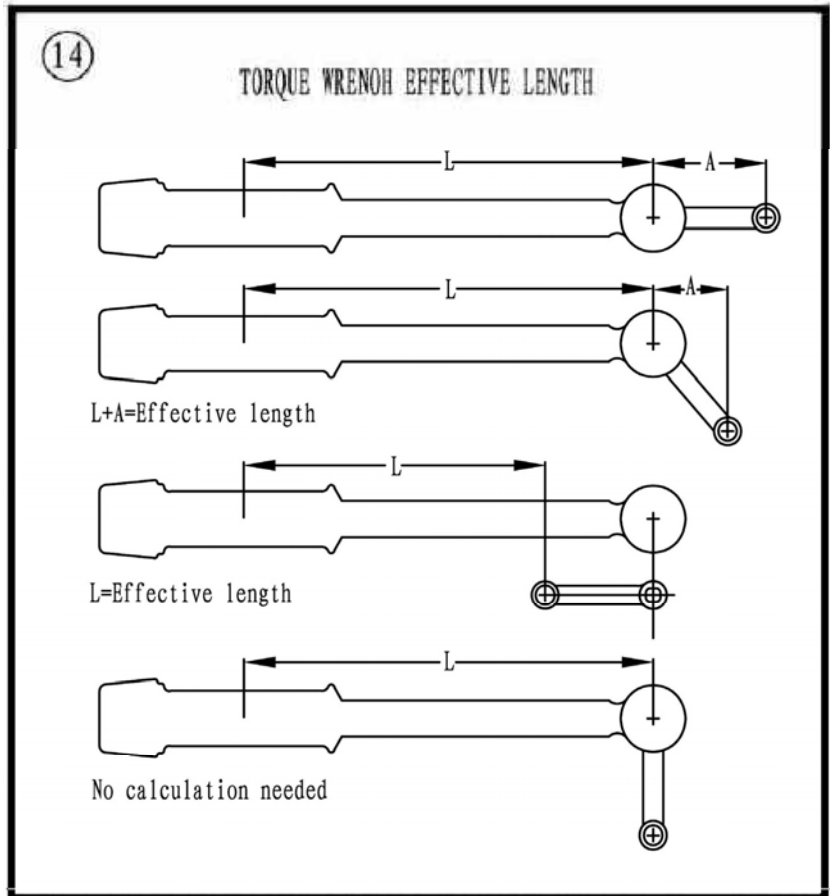

GENERAL INFORMATION

this example, although the torque wrench is pre set to 16.5 ft. –lb., the actual torque is 20 ft. –lb.

Pliers

Pliers come in a wide range of types and sizes. Pliers are useful for holding, cutting, bending, and crimping. Do not use them to turn fasteners. **Figure 15 and Figure 16** show several types of useful pliers. Each design has a specialized function. Slip-joint pliers are general – purpose pliers used for gripping and bending. Diagonal cutting pliers are needed to cut wire and can be used to remove cotter pins. Use needle nose pliers to hold or bend small objects.

Locking pliers (**Figure 16**), sometimes called Vise-Grips, are used to hold objects very tightly. They have many uses ranging from holding two parts together, to gripping the end of a broken stud. Use caution when using locking pliers, as the sharp jaws will damage the objects they hold.

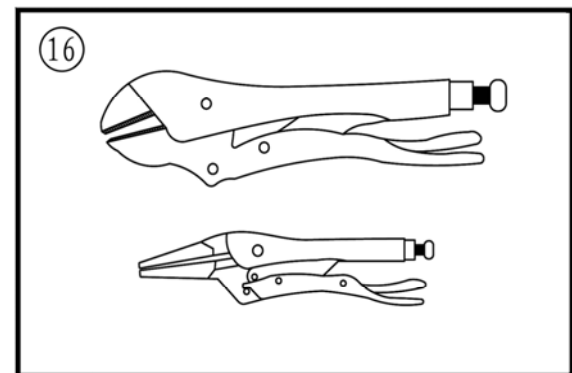
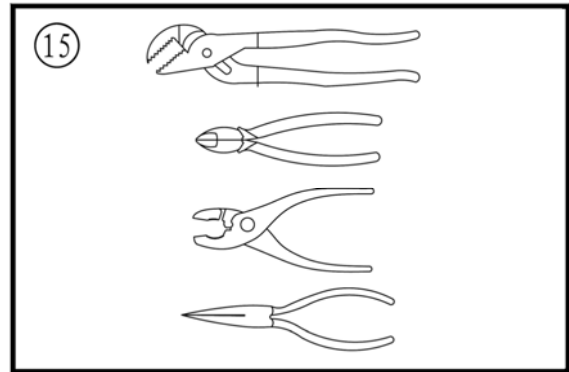

Snap Ring Pliers

Snap ring pliers are specialized pliers with tips that fit into the ends of snap rings to remove and install them.

Snap ring pliers (**Figure 17**) are available with a fixed action (either internal or external) or convertible (one tool works on both internal and external snap rings). They may have fixed tips or interchangeable ones of various sizes and angles. For general use, select a convertible type pliers with interchangeable tips (**Figure 17**).

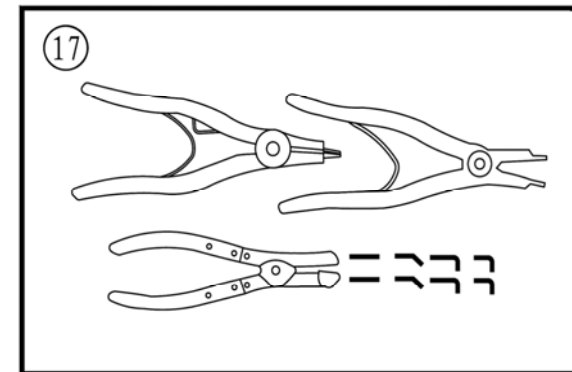

WARNING

Snap rings can slip and fly off when removing and installing them. Also, the snap ring pliers tips may break. Always wear eye protection when using snap ring pliers.

Hammers

Various types of hammers are available to fit a number of applications. Use a ball-peen hammer to strike another tool, such as a punch or chisel. Use soft-faced hammers when a metal object must

GENERAL INFORMATION

be struck without damaging it. Never use a metal-faced hammer on engine and suspension components because damage occurs in most cases.

Always wear eye protection when using hammers. Make sure the hammer face is in good condition and the handle is not cracked. Select the correct hammer for the job and make sure to strike the object squarely. Do not use the handle or the side of the hammer to strike an object.

Ignition Grounding Tool

Some test procedures require turning the engine over without starting it. To prevent damage to the ignition system from excessive resistance or the possibility of fuel vapor being ignited by an open spark, remove the spark plug cap and ground it directly to a good engine ground with the tool shown in **(Figure 18)**.

Make the tool shown from a No.6 screw and nut, two washers, length of tubing, alligator clip, electrical eyelet and a length of wire.

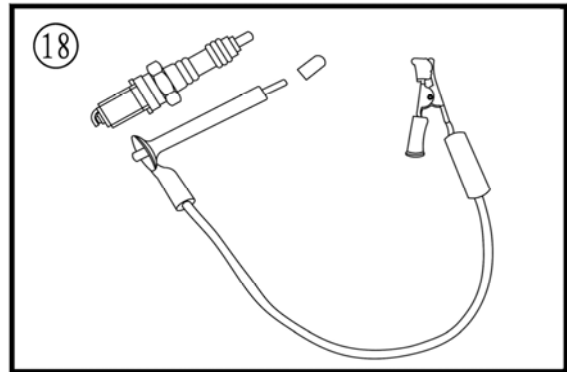

PRECISION MEASURING TOOLS

The ability to accurately measure components is essential to perform many of the procedures described in this manual. Equipment is manufactured to close tolerances, and obtaining consistently accurate measurements is essential to determine which components require replacement or further service.

Each type of measuring instrument is designed to measure a dimension with a certain degree of accuracy and within a certain range. When selecting the measuring tool, make sure it is applicable to the task.

As with all tools, measuring tools provide the best results if cared for properly. Improper use can damage the tool and cause inaccurate results. If any measurement is questionable, verify the measurement using another tool. A standard gauge is usually provided with micrometers to check accuracy and calibrate the tool if necessary.

Precision measurements can vary according to the experience of the person performing the procedure. Accurate results are only possible if the mechanic possesses a feel for using the tool. Heavy-handed use of measuring tools produces less accurate results. Hold the tool gently by the fingertips to easily feel the point at which the tool contacts the object. This feel for the equipment produces more accurate measurements and reduces the risk of damaging the tool or component. Refer to the following sections for specific measuring tools.

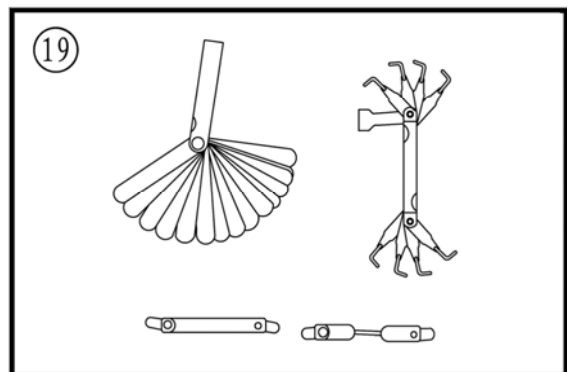

GENERAL INFORMATION

Feeler Gauge

Use feeler or thickness gauges (**Figure 19**) for measuring the distance between two surfaces.

A feeler gauge set consists of an assortment of steel strips of graduated thickness. Each blade is marked with its thickness. Blades can be of various lengths and angles for different procedures.

A common use for a feeler gauge is to measure valve clearance. Use wire (round) type gauges to measure spark plug gap.

Calipers

Calipers (**Figure 20**) are excellent tools for obtaining inside, outside and depth measurements. Although not as precise as a micrometer, they allow reasonable precision, typically to within 0.02mm or 0.05 mm (0.001 in.). Most calipers have a range up to 150 mm (6 in.).

Calipers are available in dial, vernier or digital versions. Dial calipers have a dial readout that provides convenient reading. Vernier calipers have marked scales that must be compared to determine the measurement. The digital caliper uses a liquid-crystal display (LCD) to show the measurement.

Properly maintain the measuring surfaces of the caliper. There must not be any dirt or burrs between the tool and the object being measured. Never force the caliper to close around an object. Close the caliper around the highest point so it can be removed with a slight drag. Some calipers require calibration. Always refer to the manufacturer's instructions when using a new or unfamiliar caliper.

To read a vernier. Calipers refer to **Figure 21**. The fixed scale is marked in 1-mm increments. Ten individual lines on the fixed scale equal 1 cm. The movable scale is marked in 0.05 mm (hundredth) increments. To obtain a reading, establish the first number by the location of the 0 line on the movable scale in relation to the first line to the left on the fixed scale. In this example, the number is 10 mm. To determine the next number, note which of the lines on the movable scale align with a mark on the fixed scale. A number of lines will seem close, but only one will align exactly. In this case, 0.50 mm is the reading to add to the first number. Adding 10 mm and 0.50 mm equals a measurement of 10.50 mm.

Micrometers

A micrometer is an instrument designed for linear measurement using the decimal divisions of the inch or meter (**Figure 22**). While there are many types and styles of micrometers, most of the

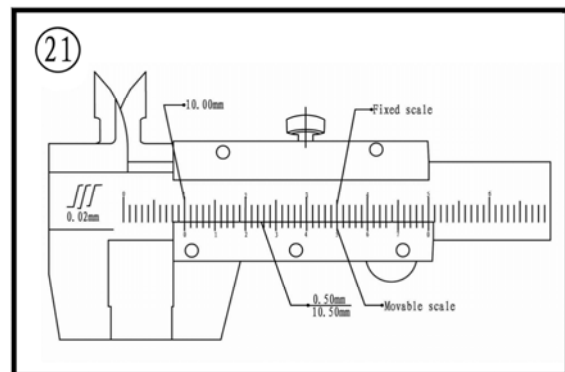
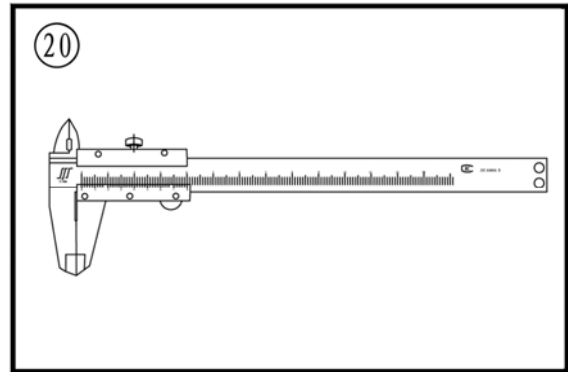

GENERAL INFORMATION

22

DECIMAL PLACE VALUES*

0.1	Indicates 1/10 (one tenth of an inch or millimeter)
0.01	Indicates 1/100 (one one-hundredth of an inch or millimeter)
0.001	Indicates 1/1000 (one one-thousandth of an inch or millimeter)

*This chart represents the values of figures placed to the right of the decimal point. Use it when reading decimals from one-tenth to one one-thousandth of an inch or millimeter. It is not a conversion chart (for example: 0.001 in. is not equal to 0.001 mm).

procedures in this manual call for an outside micrometer. Use the outside micrometer to measure the outside diameter of cylindrical forms and the thickness of materials.

A micrometer's size indicates the minimum and maximum size of a part that it can measure. The usual sizes (**Figure 23**) are 0-25mm (0-1 in.), 25-50 mm (1-2 in.), 50-75 mm (2-3 in.) and 75-100 mm (3-4 in.).

Micrometers that cover a wider range of measurements are available. These use a large frame with interchangeable anvils of various lengths. This type of micrometer offers a cost savings, but its overall size may make it less convenient.

When reading a micrometer, numbers are taken from different scales and added together. The following sections describe how to adjust, care for and read the measurements of various types of outside micrometers.

For accurate results, properly maintain the measuring surfaces of the micrometer. There cannot be any dirt or burrs between the tool and the measured object. Never force the micrometer to close around an object. Close the micrometer around the highest point so it can be removed with a slight drag.

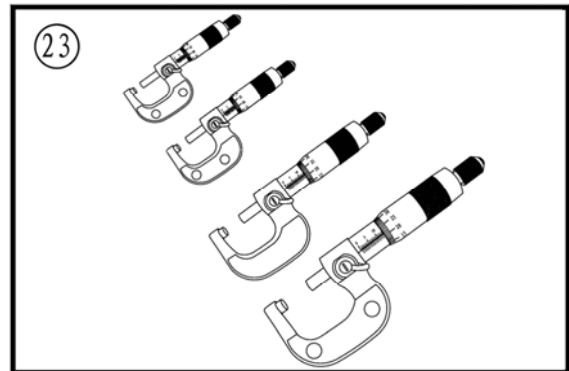

Adjustment

Before using a micrometer, check its adjustment as follows:

1. Clean the anvil and spindle faces.
- 2A. To check a 0-1 in. or 0-25 mm micrometer:
 - a. Turn the thimble until the spindle contacts the anvil. If the micrometer has a ratchet stop, use it to ensure that the proper amount of pressure is applied.
 - b. If the adjustment is correct, the 0 mark on the thimble will align exactly with the 0 mark on the sleeve line. If the marks do not align, the micrometer is out of adjustment.
 - c. Follow the manufacturer's instructions to adjust the micrometer.

GENERAL INFORMATION

- 2B. To check a micrometer larger than 1 in. or 25 mm use the standard gauge supplied by the manufacturer. A standard gauge is a steel block, disc or rod that is machined to an exact size.
- Place the standard gauge between the spindle and anvil, and measure its outside diameter or length. If the micrometer has a ratchet stop, use it to ensure that the proper amount of pressure is applied.
 - If the adjustment is correct, the 0 mark on the thimble will align exactly with the 0 mark on the sleeve line. If the marks do not align, the micrometer is out of adjustment.
 - Follow the manufacturer's instructions to adjust the micrometer.

Care

Micrometers are precision instruments. They must be used and maintained with great care. Note the following:

- Store micrometers in protective cases or separate padded drawers in a tool box.
- When in storage, make sure the spindle and anvil faces do not contact each other or another object. If they do, temperature changes and corrosion may damage the contact faces.
- Do not clean a micrometer with compressed air. Dirt forced into the tool will cause wear.
- Lubricate micrometers with WD-40 to prevent corrosion.

Metric micrometer

The standard metric micrometer (**Figure 24**) is accurate to one one-hundredth of a millimeter (0.01 mm). The sleeve line is graduated in millimeter and half millimeter increments. The marks on the upper half of the sleeve line equal 1.00 mm. Each fifth mark above the sleeve line is identified with a number. The number sequence depends on the size of the micrometer. A 0-25 mm micrometer, for example, will have sleeve marks numbered 0 through 25 in 5 mm increments. This numbering sequence continues with larger micrometers. On all metric micrometers, each mark on the lower half of the sleeve equals 0.50 mm.

The tapered end of the thimble has 50 lines marked around it. Each mark equals 0.01 mm. One complete turn of the thimble aligns its 0 mark with the first line lower half of the sleeve line or 0.50mm.

When reading a metric micrometer, add the number of millimeters and half-millimeters on the sleeve line to the number of one one-hundredth millimeters on the thimble. Perform the following steps while referring to **Figure 25**.

- Read the upper half of the sleeve line and count the number of lines visible. Each upper line

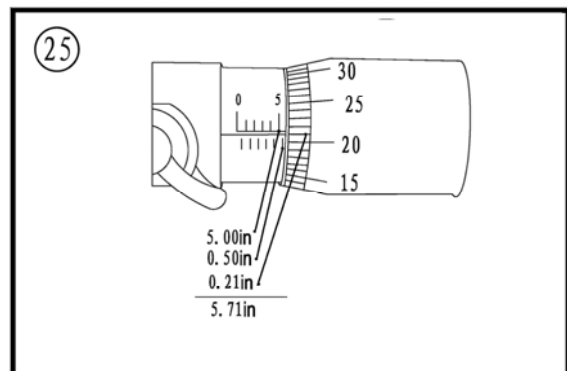
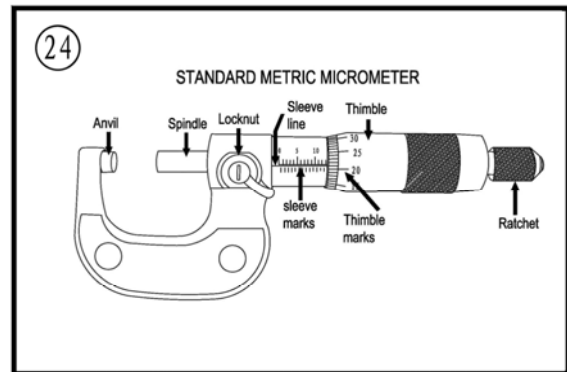

GENERAL INFORMATION

equals 1mm.

2. See if the half –millimeter line is visible on the lower sleeve line. If so, add 0.50mm to the reading in Step 1.
3. Read the thimble mark that aligns with the sleeve line. Each thimble mark equals 0.01mm.

NOTE

If a thimble mark does not align exactly with the sleeve line. Estimate the amount between the lines. For accurate readings in two-thousandths of a millimeter (0.002mm), use a metric vernier micrometer.

4. Add the readings from Steps 1-3.

Standard inch micrometer

The standard inch micrometer (**Figure 26**) is accurate to one-thousandth of an inch or 0.001. The sleeve is marked in 0.025 in. increments. Every fourth sleeve mark is numbered 1,2,3,4,5,6,7,8,9. These numbers indicate 0.100, 0.200, 0.300, and so on.

The tapered end of the thimble has 25 lines marked around it. Each mark equals 0.001 in. One complete turn of the thimble will align its zero mark with the first mark on the sleeve or 0.025 in.

To read a standard inch micrometer, perform the following steps and refer to **Figure 27**.

1. Read the sleeve and find the largest number visible. Each sleeve number equals 0.100 in.
2. Count the number of lines between the numbered sleeve mark and the edge of the thimble. Each sleeve mark equals 0.025 in.
3. Read the thimble mark that aligns with the sleeve line. Each thimble mark equals 0.01 in.

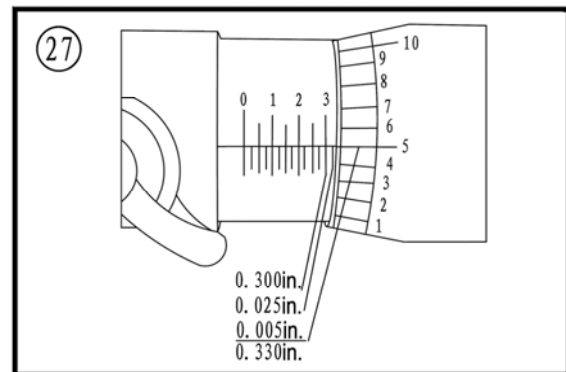
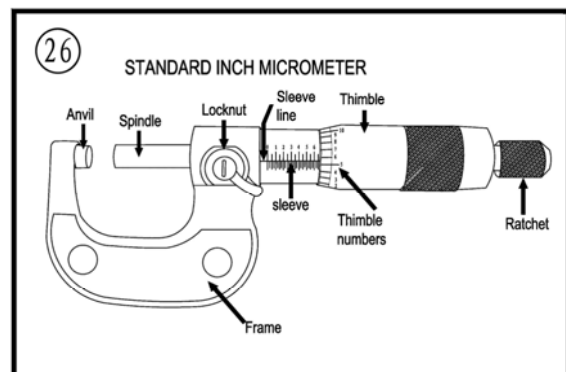

NOTE

If a thimble mark does not align exactly with the sleeve line, estimate the amount between the lines. For accurate readings in ten-thousandths of an inch (0.0001 in), use a vernier inch micrometer.

4. Add the readings from Steps 1-3.

GENERAL INFORMATION

Telescoping and Small Bore Gauges

Use telescoping gauges (**Figure 28**) and small bore gauges (**Figure 29**) to measure bores. Neither gauge has a scale for direct readings. Use an outside micrometer to determine the reading.

To use a telescoping gauge, select the correct size gauge for the bore. Compress the movable post and. Care fully insert the gauge into the bore. Carefully move the gauge in the bore to make sure it is centered. Tighten the knurled end of the gauge to hold the movable post in position. Remove the gauge and measure the length of the posts. Telescoping gauges are typically used to measure cylinder bores.

To use a small bore gauge, select the correct size gauge for the bore. Carefully insert the gauge into the bore. Tighten the knurled end of the gauge to carefully expand the gauge fingers to the limit within the bore. Do not over tighten the gauge because there is no built-in release. Excessive tightening can damage the bore surface and damage the tool. Remove the gauge and measure the outside dimension (**Figure 30**). Small bore gauges are typically used to measure valve guides.

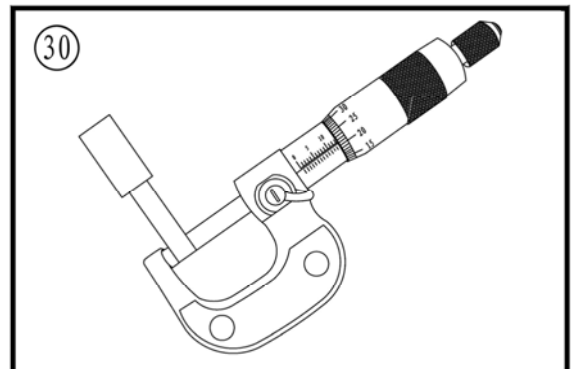
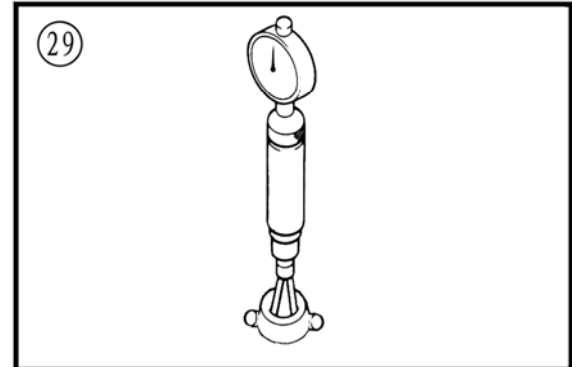
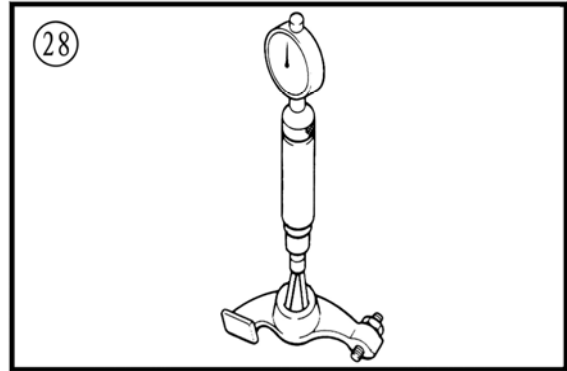

Dial Indicator:

A dial indicator (**Figure 31**) is a gauge with a dial face and needle used to measure variations in dimensions and movements. Measuring brake rotor runout is a typical use for a dial indicator.

Dial indicators are available in various ranges and graduations and with three basic types of mounting bases: magnetic (B, **Figure 31**). Clamp, or screw-in stud. When purchasing a dial indicator, select on with a continuous dial (A, **Figure 31**).

Cylinder Bore Gauge

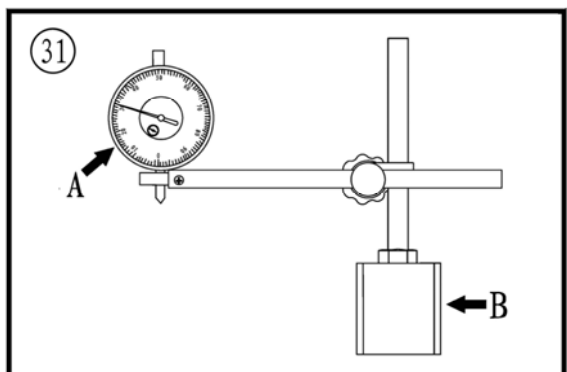

A cylinder bore gauge is similar to a dial indicator. The gauge set shown in **Figure 32** consists of a dial indicator, handle, and different length adapters (anvils) to fit the gauge to various bore sizes. The bore gauge is used to measure bore size, taper and out-of-round. When using a bore gauge, follow the manufacturer's instructions.

Compression Gauge

A compression gauge (**Figure 33**) measures combustion chamber (cylinder) pressure, usually in PSI or kg/ cm². The gauge adapter is either inserted or screwed into the spark plug hole to obtain the reading. Disable the engine so it does not start and hold the throttle in the wide-open position when performing a compression test. An engine that does not have adequate compression cannot be properly tuned. Refer to Chapter Three.

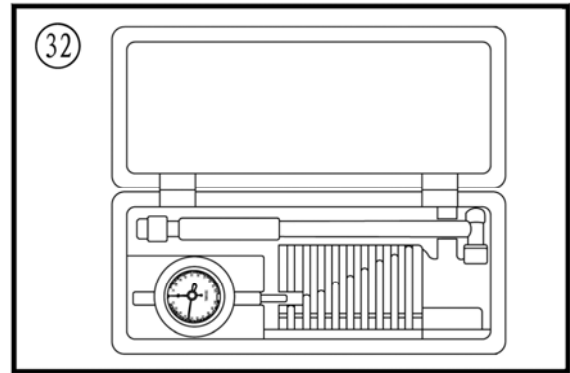

Multimeter

A multimeter (**Figure 34**) is an essential tool for electrical system diagnosis. The voltage function indicates the voltage applied or available to various electrical components. The ohmmeter function tests circuits for continuity, or lack of continuity, and measures the resistance of a circuit.

Some manufacturer's specifications for electrical components are based on results using a specific test meter. Results may vary if using a meter not recommended by the manufacturer. Such requirements are noted when applicable.

Ohmmeter (analog) calibration

Each time an analog ohmmeter is used or if the scale is changed, the ohmmeter must be calibrated. Digital ohmmeters do not require calibration.

1. Make sure the meter battery is in good condition.
2. Make sure the meter probes are in good condition.
3. Touch the two probes together and observe the needle location on the ohms scale. The needle must Align with the 0 mark to obtain accurate measurements.
4. If necessary, rotate the meter ohms adjust knob until the needle and 0 mark align.

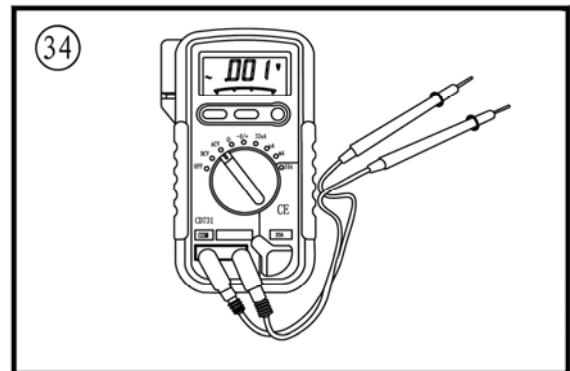
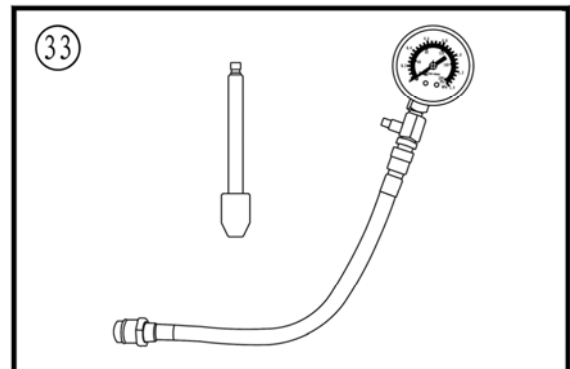

Clip-on ammeter

1. Clip-on ammeter (**Figure 35**) is the basic tool for electrical system diagnosis which is used to measure the current of charging system and other electrical components work current.

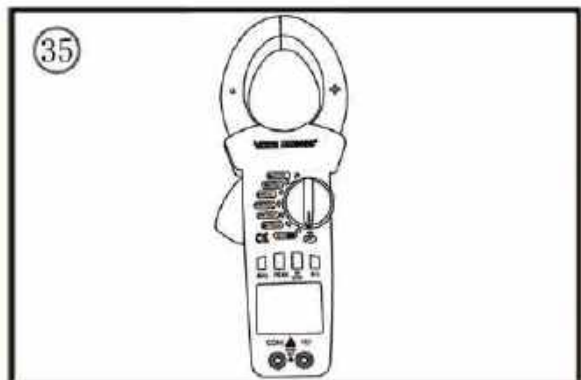

GENERAL INFORMATION

- Clip-on ammeter can measure direct current and alternating current. Please ensure that the instrument battery capacity is sufficient when work.

When measure the current, the calliper must seize the positive pole of the power. If seize the negative pole mistakenly, wrong result will appear.

Magneto puller

Magneto drawing (**figure 36**) is special tool to dismount magneto rotor. firstly put the mandril into the inside of shaft hole, Turn the magneto rotor accordingly, screw magneto drawing and push-out magneto rotor

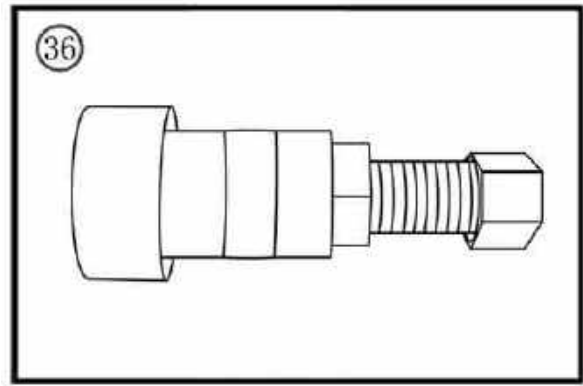

ELECTRICAL SYSTEM FUNDAMENTALS

A thorough study of the many types of electrical systems used in today's motorcycles is beyond the scope of this manual. However, a basic understanding of electrical basics is necessary to perform simple diagnostic tests.

Refer to Electrical Testing in Chapter Two for typical test procedures and equipment. Refer to Chapter Ten for specific system test procedures.

Voltage

Voltage is the electrical potential or pressure in an electrical circuit and is expressed in volts. The more pressure (voltage) in a circuit the more work can be performed.

Direct current (DC) voltage means the electricity flows in one direction. All circuits powered by a battery are DC circuits.

Alternating current (AC) means the electricity flows in one direction momentarily and then switches to the opposite direction. Alternator output is an example of AC voltage. This voltage must be changed or rectified to direct current to operate in a battery powered system.

Resistance

Resistance is the opposition to the flow of electricity within a circuit or component and is measured in ohms. Resistance causes a reduction in available current and voltage

Resistance is measured in an inactive circuit with an ohmmeter. The ohmmeter sends a small amount of current into the circuit and measures how difficult it is to push the current through the circuit.

An ohmmeter, although useful, is not always a good indicator of a circuit's actual ability under operating conditions. This is because of the low voltage (6-9 volts) the meter uses to test the circuit. The voltage in an ignition coil secondary winding can be several thousand volts. Such high voltage can cause the coil to malfunction, even though it tests acceptable during a resistance test.

Resistance generally. Increases with temperature. Perform all testing with the component or

GENERAL INFORMATION

circuit at room temperature. Resistance tests performed at high temperatures may indicate high resistance readings and cause unnecessary replacement of a component.

Amperage

Amperage is the unit of measurement for the amount of current within a circuit. Current is the actual flow of electricity. The higher the current, the more work can be performed up to a given point. If the current flow exceeds the circuit or component capacity, it will damage the system.

Warning

If the current insulation damage, may cause short circuit fault which lead to short circuit or large current in components. It may cause a fire.

Thus, if the current of circuit or components measured by amperage exceeds the standard level, must check and repair electrical system at once.

BASIC SERVICE METHODS

Most of the procedures in this manual are straightforward and can be performed by anyone reasonably competent with tools. However, consider personal capabilities carefully before attempting any operation involving major disassembly.

1. Front, in this manual, riders to the front of the ATV, The front of any component is the end closest to the front the ATV. The left and right sides refer to the position of the parts as viewed by the rider sitting on the seat facing forward.
2. Whenever servicing an engine or suspension component, secure the ATV in a safe manner.
3. Tag all similar parts for location and mark all mating parts for position. Record the number and thickness of any shims when removing them. Identify parts by placing them in sealed and labeled plastic sandwich bags.
4. Tag disconnected wires and connectors with masking tape and a marking pen. Do not rely on memory alone.
5. Protect finished surfaces from physical damage or corrosion. Keep gasoline and other chemicals off painted surfaces.
6. Use penetrating oil on frozen or tight bolts. Avoid using heat where possible. Heat can warp, melt or affect the temper of parts. Heat also damages the finish of paint and plastics.
7. When a part is a press fit or requires a special tool to remove, the information or type of tool is identified in the text. Otherwise, if a part is difficult to remove or install, determine the cause before proceeding.
8. To prevent objects or debris from falling into the engine, cover all openings.
9. Read each procedure thoroughly and compare the illustrations to the actual components before starting the procedure. Perform the procedure in
10. Recommendations are occasionally made to refer service to a dealership or specialist. In these cases, the work can be performed more economically by the specialist than by the home mechanic.
11. The term replaces means to discard a defective part and replace it with a new part. Overhaul

GENERAL INFORMATION

means to remove, disassemble, inspect, measure, repair and/or replace parts as required to recondition an assembly.

12. Some operations require using a hydraulic press. If a press is not available, have these operations performed by a shop equipped with the necessary equipment. Do not use makeshift equipment that may damage the motorcycle.
13. Repairs are much faster and easier if the ATV is clean before starting work. Degrease the motorcycle with a commercial degreaser; follow the directions on the container for the best results. Clean all parts with cleaning solvent when removing them.

CAUTION

Do not direct high-pressure water at steering bearings, fuel hoses, wheel bearings, suspension and electrical components. Water may force grease out of the bearings and possibly damage the seals

14. If special tools are required, have them available before starting the procedure. When special tools are required, they are described at the beginning of the procedure.
15. Make diagrams of similar-appearing parts. For instance, crankcase bolts are often not the same lengths. Do not rely on memory alone. Carefully laid out parts can become disturbed, making it difficult to reassemble the components correctly.
16. Make sure all shims and washers are reinstalled in the same location and position.
17. Whenever rotating parts contact a stationary part, look for a shim or washer.
18. Use new gaskets if there is any doubt about the condition of old ones.
19. If using self-locking fasteners, replace them with new ones. Do not install standard fasteners in place of self-locking ones.
20. Use grease to hold small parts in place if they tend to fall out during assembly. Do not apply grease to electrical or brake components.

Removing Frozen Fasteners

If a fastener cannot be removed, several methods may be used to loosen it. First, apply a penetrating fluid. Apply it liberally and let it penetrate for 10-15 minutes. Rap the fastener several times with a small hammer. Do not hit it hard enough to cause damage. Reapply the penetrating fluid if necessary.

For frozen screws, apply penetrating fluid as described, then insert a screwdriver in the slot and rap the top of the screwdriver with a hammer. This loosens the rust so the screw can be removed in the normal way. If the screw head is too damaged to use this method, grip the head with locking pliers and twist the screw out.

Avoid applying heat unless specifically instructed. Heat may melt, warp or remove the temper from parts.

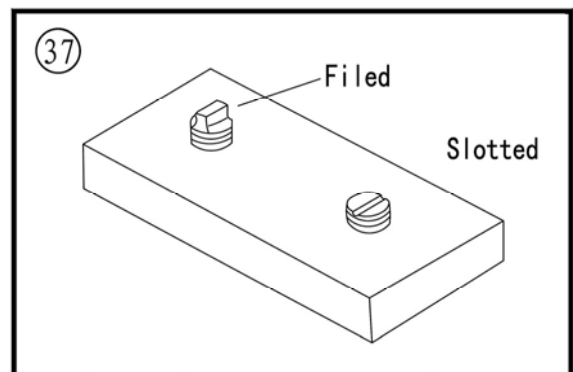

GENERAL INFORMATION

Removing Broken Fasteners

If the head breaks off a screw or bolt, several methods are available for removing the remaining portion. If a large portion of the remainder projects out, try gripping it with locking pliers. If the projecting portion is too small, file it to fit a wrench of cut a slot in it to fit a screwdriver (**Figure 37**)

If the head breaks off flush, use a screw extractor. To do this, center punch the exact center of the remaining portion of the screw or bolt. Drill a small hole in the screw and tap the extractor into the hole. Back the screw out with a wrench on the extractor (**Figure 38**)

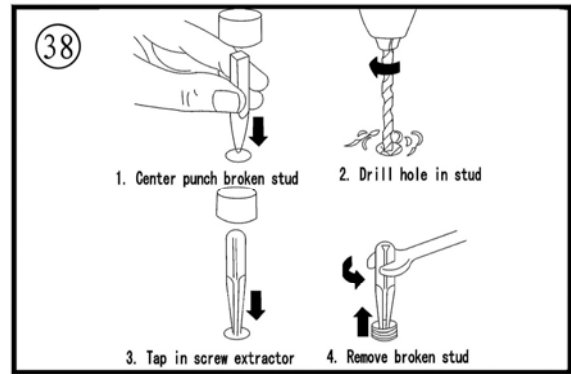

Repairing Damaged Threads

Occasionally, threads are stripped through carelessness or impact damage. Often the threads can be repaired by running a tap (for internal threads on nuts) or die (for external threads on bolts) through the threads (**Figure 39**). To clean or repair spark plug threads, use a spark plug tap.

If an internal thread is damaged, it may be necessary to install a Helical or some other type of thread insert. Follow the manufacturer's instructions when installing their insert.

If it is necessary to drill and tap a hole, refer to **Table 8** for metric tap and drill sizes.

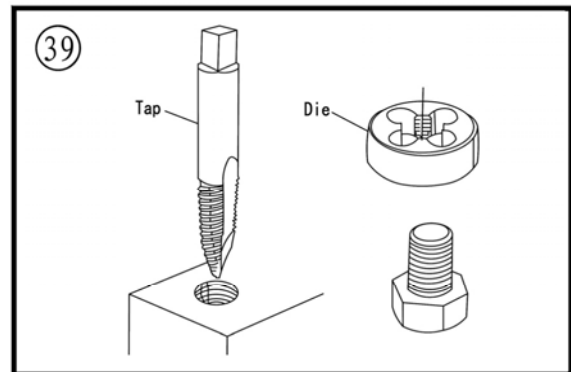

Stud Removal/Installation

A stud removal tool (**Figure 40**) is available from most tool suppliers. This tool makes the removal and installation of studs easier. If one is not available, thread two nuts onto the stud and tighten them against each other. Remove the stud by turning the lower nut (**Figure 41**).

1. Measure the height of the stud above the surface.
2. Thread the stud removal tool onto the stud and tighten it, or thread two nuts onto the stud.
3. Remove the stud by turning the stud remover or the lower nut.

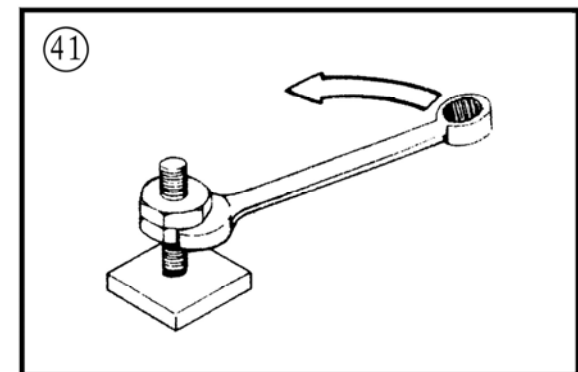
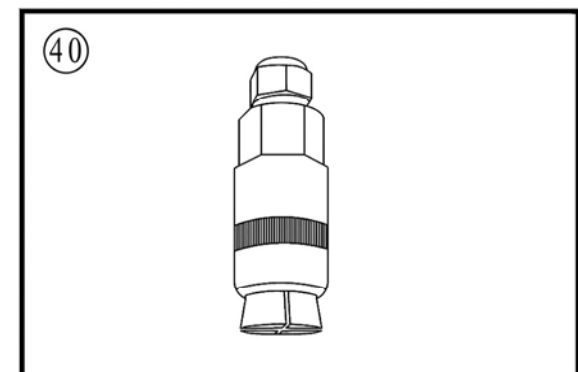

GENERAL INFORMATION

4. Remove any thread locking compound from the threaded hole. Clean the threads with an aerosol parts cleaner.
5. Install the stud removal tool onto the new stud or thread two nuts onto the stud.
6. Apply thread locking compound to the threads of the stud.
7. Install the stud and tighten with the stud removal tool or the top nut.
8. Install the stud to the height noted in Step 1 or its torque specification.
9. Remove the stud removal tool or the two nuts.

Removing Hoses

When removing stubborn hoses, do not exert excessive force on the hose or fitting. Remove the hose, do not exert excessive force on the hose or fitting. Remove the hose clamp and carefully insert a small screwdriver or pick tool between the fitting and hose. Apply a spray lubricant under the hose and carefully twist the hose off the fitting. Clean the fitting of any corrosion or rubber hose material with a wire brush. Clean the inside of the hose thoroughly. Do not use any lubricant when installing the hose (new or old). The lubricant may allow the hose to come off the fitting, even with the clamp secure.

Bearings

Bearings are used in the engine and transmission assembly to reduce power loss, heat and noise resulting from friction. Because bearings are precision parts, they must be maintained with proper lubrication and maintenance. If a bearing is damaged, replace it immediately. When installing a new bearing, take care to prevent damaging it. Bearing replacement procedures are included in the individual chapters where applicable; however, use the following sections as a guideline.

NOTE

Unless otherwise specified, install bearings with the manufacturer's mark or number facing outward.

Removal

While bearings are normally removed only when damaged, there may be times when it is necessary to remove a bearing that is in good condition. However, improper bearing removal will damage the bearing and possibly the shaft or case. Note the following when removing bearings:

1. When using a puller to remove a bearing from a shaft, take care that the shaft is not damaged. Always place a piece of metal

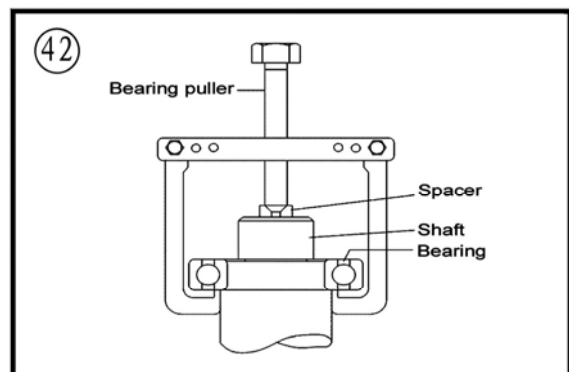

GENERAL INFORMATION

between the end of the shaft and the puller screw. In addition, place the puller arms next to the inner bearing race. See **Figure 42**.

2. When using a hammer to remove a bearing from a shaft, do not strike the hammer directly against the shaft. Instead, use a brass or aluminum rod between the hammer and shaft (**Figure 43**) and make sure to support both bearing races with wooden blocks as shown.
3. The ideal method of bearing removal is with a hydraulic press. Note the following when using a press:
 - a. Always support the inner and outer bearing races with a suitable size wooden or aluminum spacer (**Figure 44**). If only the outer race is supported, pressure applied against the balls and/or the inner race will damage them.
 - b. Always make sure the press arm (**Figure 44**) aligns with the center of the shaft. If the arm is not centered, it may damage the bearing and/or shaft.
 - c. The moment the shaft is free of the bearing, it drops to the floor. Secure or hold the shaft to prevent it from falling.

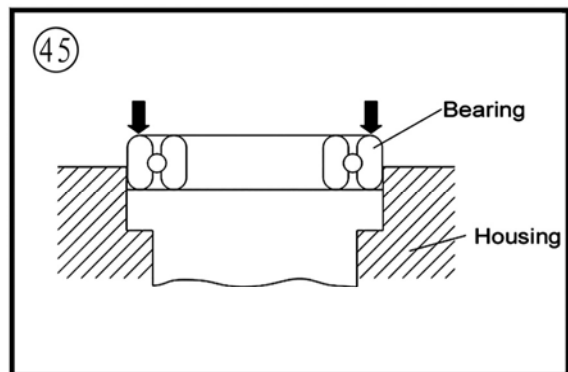
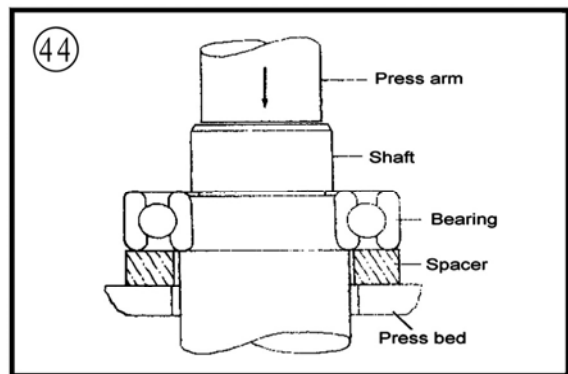
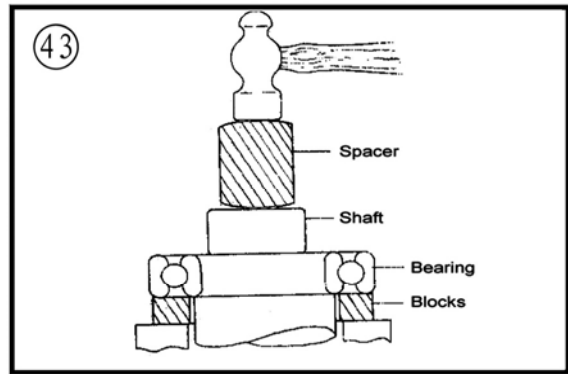

Installation

1. When installing a bearing in a housing, apply pressure to the outer bearing race (**Figure 45**). When installing a bearing on a shaft, apply pressure to the inner bearing race (**Figure 46**).
2. When installing a bearing as described in Step 1, some type of driver is required. Never strike the bearing directly with a hammer or it will damage the bearing. When installing a bearing, use a piece of pipe or a driver with a diameter that matches the bearing inner race. **Figure 47** Shows the correct way to use a driver and hammer to install a bearing.
3. Step 1 describes how to install a bearing in a case half or over a shaft. However, when installing a bearing over a shaft and into the housing at the same time, a tight fit is required for

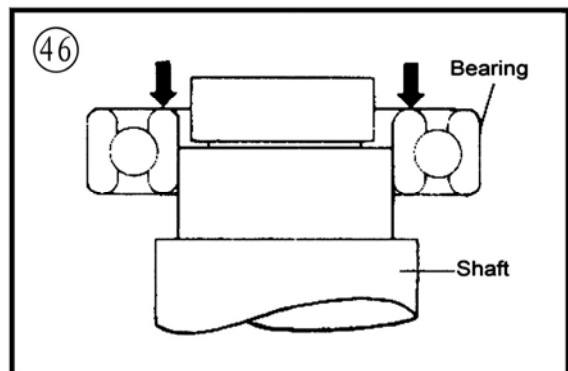

GENERAL INFORMATION

both outer and inner bearing races. In this situation, install a spacer underneath the driver tool so that pressure is applied evenly across both races. See **Figure 48**. If the outer race is not supported as shown, the balls will push against the outer bearing race and damage it

Interference fit

1. Follow this procedure when installing a bearing over a shaft. When a tight fit is required, the bearing inside diameter is smaller than the shaft. In this case, driving the bearing on the shaft using normal methods may cause bearing damage. Instead, heat the bearing before installation. Note the following:

- a. Secure the shaft so it is ready for bearing installation.
- b. Clean all residues from the bearing surface of the shaft. Remove burrs with a file or sandpaper.
- c. Fill a suitable pot or beaker with clean mineral oil. Place a thermometer rated above 120°C (248°F) in the oil. Support the thermometer so it does not rest on the bottom or side of the pot.
- d. Remove the bearing from its wrapper and secure it with a piece of heavy wire bent to hold it in the pot. Hang the bearing in the pot so it does not touch the bottom or sides of the pot.
- e. Turn the heat on and monitor the thermometer. When the oil temperature rises to approximately 120°C (248°F), remove the bearing from the pot and quickly install it. If necessary, place a socket on the inner bearing race and tap the bearing into place. As the bearing chills, it will tighten on the shaft, so install it quickly. Make sure the bearing is installed completely.

2. Follow this step when installing a bearing in a housing. Bearings are general installed in a housing with a slight interference fit Driving the bearing into the housing using normal methods may damage the housing or cause bearing damage. Instead, heat the housing before the bearing is installed. Note the following:

CAUTION

Before heating the housing in this procedure, wash the housing thoroughly with detergent and water. Rinse and rewash the cases as required to remove all traces of oil and other chemical deposits

- a. Heat the housing to approximately 100°C (212°F) in an oven or on a hot plate. An easy way to check that it is the proper temperature is to place tiny drops of water on the housing; if they

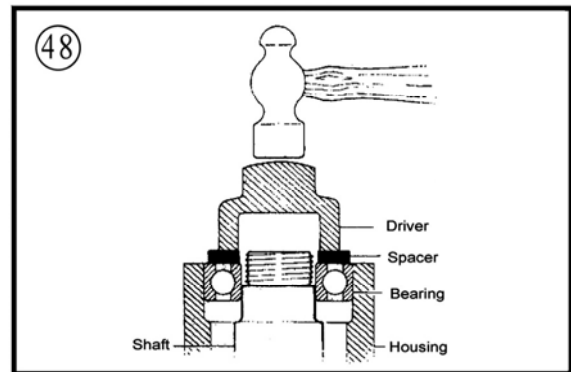
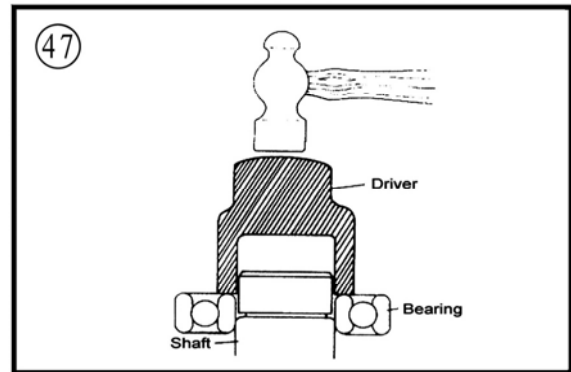

GENERAL INFORMATION

sizzle and evaporate immediately, the temperature is correct. Heat only one housing at a time.

CAUTION

Do not heat the housing with a propane or acetylene torch. Never bring a flame into contact with the bearing or housing. The direct heat will destroy the case hardening of the bearing and will likely warp the housing.

- b. Remove the housing from the oven or hot plate, and hold onto the housing with welding gloves. It is hot!

NOTE

Remove and install the bearings with a suitable size socket and extension.

- c. Hold the housing with the bearing side down and tap the bearing out. Repeat for all bearings in the housing.
- d. Before heating the bearing housing, place the new bearing in a freezer if possible. Chilling a bearing slightly reduces its outside diameter while the heated bearing housing assembly is slightly larger due to heat expansion. This makes bearing installation easier.

NOTE

Always install bearings with the manufacturer's mark or number facing outward.

- e. While the housing is still hot. Install the new bearing(s) into the housing. Install the bearings by hand, if possible. If necessary, lightly tap the bearing(s) into the housing with a driver placed on the outer bearing race (**Figure 45**). Do not install new bearings by driving on the inner-bearing race. Install the bearing(s) until it seats completely.

Seal Replacement

Seals (**Figure 49**) contain oil, water, grease or combustion gasses in a housing or shaft. Improperly removing a seal can damage the housing or shaft. Improperly installing the seal can damage the seat. Note the following:

1. Prying is generally the easiest and most effective method of removing a seal from the housing. However, Always place a rag underneath the pry tool to prevent damage to the housing. Note the seal's installed depth or if it is installed flush.
2. Pack waterproof grease in the seal lips before the seal is installed.
3. In most cases, install seals with the manufacturer's numbers or marks facing out.

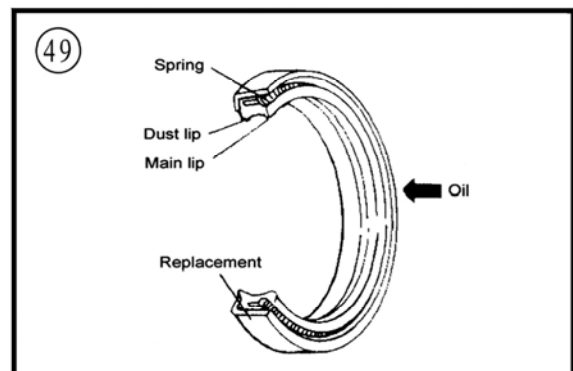

GENERAL INFORMATION

4. Install seals with a socket or driver placed on the outside of the seal as shown in. Drive the seal squarely into the housing until it is to the correct depth or flush as noted during removal. Never install a seal by hitting against the top of it with a hammer.

STORAGE

Several months of non-use can cause a general deterioration of the motorcycle, ATV. This is especially true in areas of extreme temperature variations. This deterioration can be minimized with careful preparation for storage. A properly stored motorcycle is much easier to return to service.

Storage Area Selection

When selecting a storage area, consider the following:

1. The storage area must be dry. A heated area is best, but not necessary. It should be insulated to minimize extreme temperature variations.
2. If the building has large window areas, mask them to keep sunlight off the ATV.
3. Avoid buildings in industrial areas where corrosive emissions may be present. Avoid areas close to saltwater.
4. Consider the area's risk of fire, theft or vandalism. Check with an insurer regarding ATV coverage while in storage.

Preparing the Motorcycle for Storage

The amount of preparation a motorcycle should undergo before storage depends on the expected length of non-use, storage area conditions and personal preference. Consider the following list the minimum requirement:

1. Wash the ATV thoroughly. Make sure all dirt, mud and other debris are removed.
2. Lubricate the drive chain.
3. Start the engine and allow it to reach operating temperature. Drain the engine oil regardless of the riding time since the last service. Fill the engine with the recommended type of oil.
4. Drain the fuel tank, fuel lines and throttle.
5. Remove the spark plug and ground the ignition system with a grounding tool as described in this chapter. Then pour a teaspoon (15-20ml) of engine oil into the cylinder. Place a rag over the opening and start the engine over to distribute the oil. Remove the grounding tool and reinstall the spark plug.
6. When the engine has cooled to room temperature, drain the cooling system. Drain the coolant in the coolant reserve tank and all tank lines.
7. Cover the exhaust and intake opening.
8. Apply a protective substance to the plastic and rubber components. Make sure to follow the manufacturer's instructions for each type of product being used.
9. Place the ATV on a work stand with both wheels off the ground.
10. Cover the ATV with old bed sheets or something similar. Do not cover it with any plastic material that will trap moisture.

GENERAL INFORMATION

Returning the ATV to Service

The amount of service required when returning a ATV to service after storage depends on the length of non-use and storage conditions. In addition to performing the reverse of the procedure, note the following:

1. Remove the covers from the intake and exhaust openings.
2. Service the air filter as described in Chapter Three.
3. Inspect the cooling system. Check the drain plug and hose connections for leaks.
4. Refill the fuel tank. Turn the fuel shutoff valve on and check for fuel leaks.
5. Make sure the brakes, clutch, throttle and engine stop switch work properly before operating the ATV. Evaluate the service intervals to determine which areas require service.
6. If the ATV has been in storage for longer than four months, change the engine oil as and filter, and the transmission oil as described

TROUBLESHOOTING

Diagnose electrical and mechanical problems by following an orderly procedure and remembering the basic operating requirements

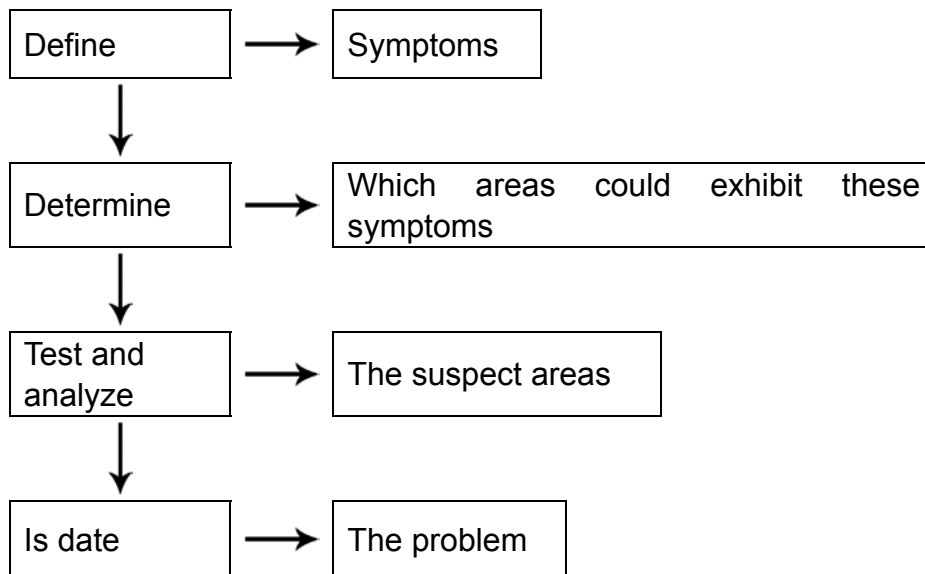

By following a systematic approach, the possibility of unnecessary parts replacement can be avoided, always start with the simple and most obvious checks when troubleshooting, This would include the engine stop switch, fuel quantity and condition, fuel vale position and spark plug cap tightness

Proper maintenance as described in Chapter Three reduces the necessity for troubleshooting. Even with the best of care, however, the motorcycle may develop problems that require trouble shooting.

If the problem cannot be solved. Stop and evaluate all conditions prior to the problem. If the motorcycle must be taken to a repair facility, the mechanic will want to know as many details as

GENERAL INFORMATION

possible.

For removal, installation and test procedures for some components, refer to the specific chapter. When applicable, tables at the end of each chapter also provide specifications and service limits.

ENGINE PRINCIPLES AND OPERATING REQUIREMENTS

An engine needs three basics to run properly:

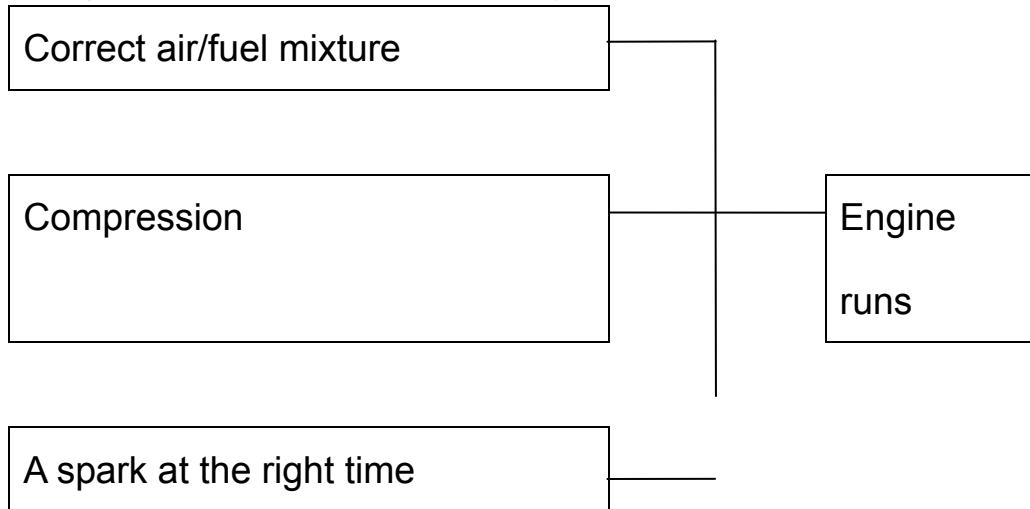

If one basic requirement is missing the engine will not run.

STARTING THE ENGINE

When experiencing engine-starting troubles, it is easy to work out of sequence and forget basic starting procedures. The following sections describe the recommended starting procedures.

Several special faults and countermeasures of EFI engine system

1.Special fault:

Idle speed is too high at starting moment.

The engine start normally, the engine speed will be a little higher than normal idle speed (1400rpm) within the first 10 seconds. According to different temperature of engine coolant, the process will continue from several seconds to tens of seconds.

Finally, the engine speed will decrease to normal idle speed automatically.

Reason: The intelligent control function of EFI automatically forces to complete the engine warm-up process and enhance the oil pressure to correct level at the same time.

Result: Ensure the engine can work with steady idle speed and conducive to complete the engine warm-up process quickly after start engine in low temperature.

2.Special fault:

Idle instability, CH and CO of off-gas out of limits

Reason: Oxygen sensor loosing cause slight leakage or pipe slight leakage and makes the oxygen sensor collect too much oxygen ion signal. The wrong signal transmits to the ECU which result the increasing of oil supply. Finally, it causes the oil too thick.

3.Special fault:

GENERAL INFORMATION

In the vehicle driving process, there is no idle speed or too low idle speed when restart it after storage battery power off abnormally.

Countermeasure: Step on the throttle slightly when start the engine and maintain for a few seconds. And then let go of the throttle, remove the key and switch off the vehicle. After waiting for ten minutes, switch on with the key that could restart the engine.

4.Special fault:

The engine can't start normally after changing air filter or air throttle

Reason: The inner cleanness of old air filter and air throttle is poor after long running. The idle speed step motor will revise the volume of air up automatically. If change to new air filter or air throttle, idle speed step motor inside ECU need to match the volume of oil when in idle speed automatically.

Countermeasure: When start the engine, run 2 to 3 minutes in idle speed. If it can't run normally in idle, turn off the engine and restart it repeatedly 10 seconds later until it can run normally in idle. Or switch on and off the key 5 times in a row which can reset all saved data in ECU.

Engine is cold

1. Shift the transmission into neutral.
2. Turn the fuel valve on or confirm if the fuel is in upper or below retile in the fuel tank.
3. Start the engine and run in neutral for 1 minute to enhance the temperature of engine. If it runs normally in neutral, you can drive the ATV.

NOTE

Race the engine with high power in low temperature will cause damage to the engine.

Engine is warm

1. Shift the transmission into neutral.
2. Confirm if the fuel is in upper or below retied in the tank.
3. Start the engine. If the engine can run in idle speed steady and the engine speed is lower than 1600RPM, the ATV can shift driving forward.

NOTE

Shift operation must be after ATV has stopped and the engine speed has reduced to idle speed (1450RPM).

Starting the engine after a fall or after the engine stalls

1. Shift the transmission into neutral.
2. Release the hot start lever as the engine starts.
3. If the engine fails to start, refer to Flooded Engine in this section.

Flooded engine

GENERAL INFORMATION

If the engine fails to start after several attempts, it is probably flooded. This occurs when too much fuel is drawn into the engine and the spark plug fails to ignite it. The smell of gasoline is often evident when the engine is flooded. Troubleshoot a flooded engine as follows:

1. Open the throttle fully and hold in this position. Then start the engine firmly through its entire stroke ten times to clear the engine. Close the throttle.
2. Check and repair ignition system.
3. If the engine still does not start, refer to Engine will Not Start this chapter.

ENGINE WILL NOT START

Identifying the Problem

If the engine does not start, perform the following steps in order while remembering the Engine Principals and Operating Requirements described in this chapter. If the engine fails to start after performing these checks, refer to the troubleshooting procedures indicated in the steps. If the engine starts, but idles or runs roughly, refer to Poor Engine Performance in this chapter.

1. Refer to Starting the Engine in this chapter to make sure all starting procedures are correct.
2. If the engine seems flooded, refer to Starting The Engine in this chapter. If the engine is not flooded, continue with Step 3.
3. Remove the cap from the fuel tank and make sure the fuel tank and make sure the fuel tank has a sufficient amount of fuel to start the engine.
4. If there is sufficient fuel in the fuel tank, remove the spark plug immediately after attempting to start the engine. The plug's insulator should be wet, indicating that fuel is reaching the engine. If the plug tip is dry, fuel is not reaching the engine. Refer to Fuel System in this chapter. If there is fuel on the spark plug and the engine will not start, the engine may not have adequate spark. Continue with Step 5.
5. Make sure the direct ignition coil or spark plug wire is secure. Push the direct ignition coil or spark plug cap and slightly rotate it to clean the electrical connection between the plug and the connector. If the engine does not start. Continue with step 6

NOTE

A cracked or damaged direct ignition coil or spark plug cap and cable can cause intermittent problems that are difficult to diagnose. If the engine occasionally misfires or cuts out, use a spray bottle to wet the direct ignition coil or plug cap and plug cable while the engine is running. Water that enters one of these areas causes an arc through the insulating material, causing an engine misfire.

NOTE

GENERAL INFORMATION

Engine misfire can also be caused by water that enters through connectors. Check the connectors for loose wire ends. On waterproof connectors, check for damage where the wires enter the connector.

6. Perform the Spark Test in this section. If there is a strong spark, perform Step 7. If there is no spark or if the spark is very weak, refer to Ignition System Testing in Chapter Ten.
7. If the fuel and ignition systems are working correctly, perform a leak down test (this chapter) and cylinder compression test. If the leak down test indicates a problem, or the compression under Engine in this chapter.

Spark Test

Perform a spark test to determine if the ignition system is producing adequate spark. This test should be performed with a spark tester. A spark tester looks like a spark plug with an adjustable gap between the center electrode and grounded base. Because the voltage required to jump the spark tester gap is sufficiently larger than that of a normally gapped spark plug, the test results are more accurate than with a spark plug. Do not assume that because a spark jumped across a spark plug gap, the ignition system is working correctly.

Perform this test on the engine when it is both cold and hot, if possible. If the test results are positive for each test, the ignition system is working correctly.

CAUTION

After removing the direct ignition coil or spark plug cap and before removing the spark plug in Step 1, clean the area around the spark plug with compressed air. Dirt that falls into the cylinder causes rapid engine wear.

1. Disconnect the direct ignition coil or spark plug cap. Check for the presence of water.
2. Visually inspect the spark plug for damage.
3. Connect a spark tester to the direct ignition coil or spark plug cap. Ground the spark tester base (or spark plug) to a good ground. Position the spark tester or spark plug firing tip away from the open spark plug hole. Position the spark tester so the electrodes are visible.

WARNING

Mount the spark tester or spark plug away from the spark plug hole in the cylinder. If the engine is flooded, do not perform this test. The spark tester can ignite fuel ejected through the spark plug hole.

4. Shift the transmission into neutral.

GENERAL INFORMATION

WARNING

Do not hold the spark tester, spark plug or connector or a serious electrical shock may result.

5. Turn the engine over using the starter and push the starter button. A fat blue spark must be evident between the spark tester or spark plug terminals.
6. If there is a strong, blue spark, the ignition system is functioning properly, Check for one or more of the following possible malfunctions:
 - a. Faulty fuel system component.
 - b. Flooded engine.
 - c. engine damage(low compression).
7. If the spark was weak (white or yellow) or if there was no spark, perform the peak voltage checks described under Ignition System Testing.
8. Reinstall the fuel tank.

The Starter Cannot Work Repeatedly Or Can Only Work Slowly

Refer to Starting System Testing

POOR ENGINE PERFORMANCE

If the engine runs, but performance is unsatisfactory, refer to the following section that best describes the symptoms.

The Engine Starts Slowly Or Difficultly

Check for the following:

1. Incorrect choke operation. This can be due to improper use or a stuck choke valve in the throttle.
2. Incorrect hot start valve operation. This situation can be due to improper use or incorrect hot start valve adjustment.
3. The fuel tank connection hose is clogged.
4. The fuel hose is clogged or the oil filter is clogged.
5. The injector is clogged.

NOTE

If a warm or hot engine will start with the choke on, or if a cold engine starts and runs until the choke is turned off. The pilot jet is probably plugged.

6. Contaminated or stale fuel.
7. Clogged air filter.
8. Intake pipe air leak.
9. Plugged exhaust system. Check the silencer or muffler, especially if the utility terrain vehicle was just returned from storage.

GENERAL INFORMATION

10. Faulty ignition system component.

Engine Backfires, Cuts Out or Misfires During Acceleration

A backfire occurs when fuel is burned or ignited in the exhaust system.

1. A lean air/fuel mixture can cause these engine performance problems. Check for the following conditions:
 - a. Incorrect float level adjustment.
 - b. Plugged pilot jet or pilot system.
2. Faulty accelerator pump.
3. Loose exhaust pipe-to-cylinder head connection.
4. Intake air leak.
5. Incorrect ignition timing or a damaged ignition system can cause these conditions. Perform the Peak Voltage Tests to isolate the damaged ignition system component. Check the ignition timing as described.

NOTE

The ignition timing is controlled by the ICM and cannot be adjusted. However, checking the ignition timing can be used to diagnose problems.

6. Check the following engine components:
 - a. Broken valve springs.
 - b. Stuck or leaking valves.
 - c. Worn or damaged camshaft lobes.
 - d. Incorrect valve timing due to incorrect camshaft installation or a mechanical failure.

Engine Backfires on Deceleration

If the engine backfires when the throttle is released, check the following:

1. Lean throttle pilot system.
2. Loose exhaust pipe-to-cylinder head connection.
3. Faulty ignition system component.
4. Check the following engine components:
 - a. Broken valve springs.
 - b. Stuck or leaking valves.
 - c. Worn or damaged camshaft lobes.
 - d. Incorrect valve timing due to incorrect camshaft installation or a mechanical failure.

Poor Fuel Mileage

1. Clogged fuel system.
2. Dirty or clogged air filter.
3. Incorrect ignition timing.

Engine Will Not Idle or Idles Roughly

GENERAL INFORMATION

1. Clogged air filter element.
2. Poor fuel filter or fuel hose.
3. Faulty accelerator pump assembly.
4. Contaminated or stale fuel.
5. Incorrect throttle adjustment.
6. Leaking head gasket.
7. Intake air leak.
8. Incorrect ignition timing
9. Low engine compression

Low Engine Power

1. Support the ATV in a stand with the rear wheel off the ground. then spins freely. If the wheel does not spin freely. Check for the following conditions:
 - a. Dragging brakes. Check for this condition immediately after riding the ATV

NOTE

After riding the ATV. Come to a stop on a level surface. Turn the engine off and shift the transmission into neutral. Walk or push the ATV forward. If the ATV is harder to push than normal. Check for dragging brakes

- b. Damaged or binding drive system
 - c. Damaged drive system and gear bearing
2. Test ride the ATV and accelerate quickly from first to second gear. If the engine speed in-creased according to throttle position. Perform **Step 3**. If the engine speed did not increase. Check CVT
 - a. Warped clutch plates/discs
 - b. CVT spring
3. Test rides the ATV and accelerate lightly. If the engine speed increased according to throttle position. Perform Step 4. If the engine speed did not increase. Check for one or more of the following problems:
 - a. Clogged air filter
 - b. Restricted fuel flow
 - c. Pinched fuel tank breather hose (Figure 9).
 - d. Clogged or damaged silencer or muffler

NOTE

A clogged exhaust system will prevent some of the burned exhaust gasses from exiting the exhaust port at the end of the exhaust stroke. This condition effects the incoming air/fuel mixture on the intake stroke and reduces engine power

4. Check for retarded ignition timing. A decrease in power results when the plugs fire later than normal
5. Check for one or more of the following problems

GENERAL INFORMATION

- a. Low engine compression
 - b. Worn spark plug
 - c. Fouled spark plug
 - d. Incorrect spark plug heat range
 - e. Weak ignition coil
 - f. Incorrect ignition timing
 - g. Plugged throttle passages
 - h. Incorrect oil level (too high or too low)
 - i. Contaminated oil
 - j. Worn or damaged valve train assembly
 - k. Engine overheating
6. If the engine knocks when it is accelerated or when running at high speed. Check for one or more of the following possible malfunctions:
- a. Incorrect type of fuel
 - b. Lean fuel mixture
 - Advanced ignition timing

NOTE

Other signs of advanced ignition timing are engine overheating and hard or uneven engine starting

- d. Excessive carbon buildup in combustion chamber
- e. Worn pistons and/or cylinder bores

Poor Idle or Low Speed Performance

1. Check for an incorrect pilot screw adjustment
2. Check for damaged or loose intake pipe and air filter housing hose clamps. These conditions will cause an air leak
3. Perform the spark test in this chapter. Note the following:
 - a. If the spark is good. Go to Step 4
 - b. If the spark is weak. *Perform the Peak Voltage Testing*
4. Check the ignition timing. If ignition timing is correct. Perform Step 5. If the timing is incorrect. Perform the *Peak Voltage Testing*
5. Check the fuel system as described in this chapter

Poor High Speed Performance

1. Check ignition timing. If the ignition timing is correct. Perform Step 2. If the timing is incorrect. Perform the *Peak Voltage*
2. Check the fuel system as described in this chapter
3. Check the valve clearance as described. Note the following:
 - a. If the valve clearance as correct. Perform Step 4
 - b. If the clearance is incorrect. adjust the valves as described in Chapter Three
4. Incorrect valve timing and worn or damaged valve springs can cause poor high-speed

GENERAL INFORMATION

performance. If the camshaft was timed just before the ATV experiencing this type of problem. The cam timing may be incorrect. If the cam timing was not set or changed. And all the other inspection procedures in this section failed to locate the problem. Inspect the camshaft and calve assembly

FUEL SYSTEM

The following section isolates common fuel system problems under specific complaints. If there is a good spark. Poor fuel flow may be preventing the correct amount of fuel from being supplied to the spark plug. Troubleshoot the fuel system as follows:

1. Clogged fuel tank breather hose
2. Check that there is a sufficient amount of fuel in the tank
3. Start the engine after the following examination. Remove the spark plug, see if there is fuel on the end of it.

Note the following:

- a. If there is no visible fuel on the end of the spark plug, go to check whether the fuel valve, oil injector or fuel hose is clogged.
- b. If the spark plug at the bottom of a fuel. And the engine has spark. Check for an excessive intake air leak or the possibility of contaminated or stale fuel.

NOTE

If the ATV was not used for some time. And was not properly stored. The fuel may have gone stale. Where lighter parts of the fuel have evaporated. Depending on the condition of the fuel. a no-start condition can result

- c. If there is too much fuel on the end of the spark plug, go to check whether there is overflow at the air filter or the ducting damper.

Rich Mixture

The following conditions can cause a rich air/fuel mixture:

1. Air pressure sensor, oxygen sensor, solar term door position sensor fault
2. ECU program error or damage

Lean Mixture

The following conditions can cause a lean air/fuel mixture:

1. The injector is clogged
2. The pump pressure is not enough
3. ECU program chaos

GENERAL INFORMATION

4. ECU damage
5. The pressure sensor, oxygen sensor, solar term door position sensor fault

ENGINE

Engine Smoke

The color of engine smoke can help diagnose engine problems or operating conditions

Black smoke

Black smoke is an indication of a rich air/fuel mixture

Blue smoke

Blue smoke indicates that the engine is burning oil in the combustion chamber as it leaks past worn valve stem seals and piston rings. Excessive oil consumption is another indicator of an engine that is burning oil. Perform a compression test to isolate the problem.

White smoke or steam

It is normal to see white smoke or steam from the exhaust after first starting the engine in cold weather. This is actually condensed steam formed by the engine during combustion. If the ATV is ridden far enough, the water cannot collect in the crankcase and should not become a problem. Once the engine heats up to normal operating temperature, the water evaporates and exits the engine through the crankcase vent system. However, if the ATV is ridden for short trips or repeatedly started and stopped and allowed to cool off without the engine getting warm enough, water will start to collect in the crankcase. With each short run of the engine, more water collects. As this water mixes with the oil in the crankcase, sludge is produced. Sludge can eventually cause engine damage as it circulates through the lubrication system and blocks off oil passages.

Large amounts of steam can also be caused by a cracked cylinder head or cylinder block surface that allows coolant to leak into the combustion chamber. Perform a Coolant System Pressure Test.

Low Engine Compression

Problems with the engine top end will affect engine performance. When the engine is suspect, perform the leak down procedure in this chapter and make a compression test. Interpret the results as described in each procedure to troubleshoot the suspect area. An engine can lose compression through the following areas:

1. Valves:
 - a. The gap between the valve is not suitable.
 - b. Incorrect valve timing.
 - c. Worn or damaged valve seat surfaces.
 - d. Bent valves.

GENERAL INFORMATION

- e. Weak or broken valve springs.
2. Cylinder head:
 - a. Loose spark plug or damaged spark plug hole.
 - b. Damaged cylinder head gasket.
 - c. Warped or cracked cylinder head.
3. The pressure relief system is damaged.

High Engine Compression

1. Faulty decompress or assembly.
2. Excessive carbon buildup in the combustion chamber.

Engine Overheating

(Cooling System)

WARNING

Do not remove the radiator cap, coolant drain plug or disconnect any coolant hose immediately after or during engine operation. Scalding fluid and steam may be blown out under pressure and cause serious injury. When the engine has been operated, the coolant is very hot and under pressure. Attempting to remove the items when the engine is hot can cause the coolant to spray violently from the radiator, water pump or hose, causing severe burns and injury.

1. Low coolant level.
2. Air in cooling system.
3. Clogged radiator, hose or engine coolant passages.
4. Worn or damaged radiator cap.
5. Damaged water pump.

Engine Overheating

(Engine)

1. Improper spark plug heat range.
2. Low oil level.
3. Oil not circulating properly.
4. Valves leaking.
5. Heavy carbon deposits in the combustion chamber.
6. Dragging brake(s).
7. Slipping clutch.

The Ignition Advance Angle Is Too Large

Preignition is the premature burning of fuel and is caused by hot spots in the combustion chamber. Glowing deposits in the combustion chamber, inadequate Cooling or an overheated spark plug can all cause preignition. This is first noticed as a power loss but eventually causes damage to the internal parts of the engine because of the high combustion chamber temperature.

Detonation

Detonation is the violent explosion of fuel in the combustion chamber before the proper time of ignition. Using low octane gasoline is a common cause of detonation.

Even when using a high octane gasoline, detonation can still occur. Other causes are over-advanced ignition timing, lean air/fuel mixture at or near full throttle, inadequate engine cooling, or the excessive accumulation of carbon deposits in the combustion chamber.

Continued detonation can result in engine damage.

Power Loss

Refer to Poor Engine Performance in this chapter.

Engine Noises

Unusual noises are often the first indication of a developing problem. Investigate any new noises as soon as possible. Something that may be a minor problem, if corrected, could prevent the possibility of more extensive damage.

Use a mechanic's stethoscope or a small section of hose held near your ear (not directly on your ear) with the other end close to the source of the noise to isolate the location. Determining the exact cause of a noise can be difficult. If this is the case, consult with a professional mechanic to determine the cause. Do not disassemble major components until all other possibilities have been eliminated.

Consider the following when troubleshooting engine noises:

1. Knocking or pinging during acceleration can be caused by using a lower octane fuel than recommended. May also be caused by poor fuel. Pinging can also be caused by an incorrect spark plug heat range or carbon buildup in the combustion chamber.
2. Slapping or rattling noises at low speed or during acceleration—May be caused by excessive piston-to-cylinder wall clearance (piston slap).

NOTE

Piston slap is easier to detect when the engine is cold and before the piston has expanded. Once the engine has warmed up, piston expansion reduces piston-to-cylinder clearance.

3. Knocking or rapping while decelerating—Usually caused by excessive rod bearing clearance.

GENERAL INFORMATION

4. Persistent knocking and vibration occurring every crankshaft rotation—Usually caused by worn rod or main bearing(s). Can also be caused by broken piston rings or a damaged piston pin.
5. Rapid on-off squeal—Compression leak around cylinder head gasket or spark plug(s).
6. Valve train noise—Check for the following:
 - a. Excessive valve clearance.
 - b. Worn or damaged camshaft.
 - c. Damaged camshaft.
 - d. Worn or damaged valve train components.
 - e. The valve hose hole is damaged.
 - f. The valve sticks on the hose.
 - g. Broken valve spring.
 - h. Low oil pressure.
 - i. Clogged cylinder oil hole or oil passage.

ENGLNE LUBRICATION

An improperly operating engine lubrication system quickly leads to engine seizure. Check the engine oil level and oil pressure.

HIGH OIL CONSUMPTION OR EXCESSIVE

Exhaust Smoke

1. Worn valve guides.
2. Worn valve guide seals.
3. Worn or damaged piston rings.
4. Incorrect piston ring installation.

Low Oil Pressure

1. Low oil level.
2. Worn or damaged oil pump.
3. Clogged oil strainer screen.
4. Clogged oil filter.
5. Internal oil leakage.
6. Oil relief valve stuck open.
7. Incorrect type of engine oil.

High Oil Pressure

1. Oil relief valve stuck closed.

GENERAL INFORMATION

2. Clogged oil filter.
3. Clogged oil gallery or metering orifices.

No Oil Pressure

1. Low oil level.
2. Oil relief valve stuck closed.
3. Damaged oil pump.
4. Incorrect oil pump installation.
5. Internal oil leak.

Oil Level Too Low

1. Oil level not maintained at correct level
2. Worn piston rings.
3. Worn cylinder.
4. Worn valve guides.
5. Worn valve guide seals.
6. Piston rings incorrectly installed during engine overhaul.
7. External oil leakage.
8. Oil leaking into the cooling system.

Oil Contamination

1. Blown head gasket allowing coolant to leak into the engine.
2. Coolant leak.
3. Oil and filter not changed at specified intervals or when operating conditions demand more frequent changes.

CYLINDER LEAK DOWN TEST

A cylinder leak down test can accurately pinpoint engine leakage problems from the head gasket, water jackets in the cylinder head and cylinder, valves and valve seats, and piston rings. This test is performed by applying compressed air to the cylinder through a special tester and then measuring the percent of leakage. A cylinder leak down tester and an air compressor are needed to perform this test.

When performing a leak down test, the engine is first set at TDC on its compression stroke so that all the valves are closed. When the combustion chamber is pressurized, very little air should escape. However, the difficulty in performing a leak down test on a single cylinder engine (especially on the engines described in this manual with low static engine compression) is in preventing the piston from moving as the combustion chamber starts to pressurize. Any piston movement will force the crankshaft to turn away from TDC and allow air to escape past an open valve seat.

In this procedure it will be necessary to lock the engine at TDC on its compression stroke and

GENERAL INFORMATION

then perform the leak down test. Follow the manufacturer's directions along with the follow the manufacturer's directions along with the following information when performing a cylinder leak down test.

1. Support the ATV on a work stand with the rear wheel off the ground.
2. Remove the air filter assembly Open and secure the throttle so it is at its wide-open position.
3. Remove the spark plug.
4. Install the threaded hose adapter from the leak down kit. Then install the leak down gauge onto the hose.
5. Remove the ignition timing hole cap from the left crankcase cover.
6. Remove the crankshaft hole cap from the right crankcase cover.

NOTE

Because the following test is performed with the cylinder head cover installed on the engine, the camshaft lobes cannot be viewed to ensure that the engine is positioned at TDC on its compression stroke. To determine when the engine is approaching TDC on its compression stroke, or whether it is 360°off. Observe the following two indicators to predict engine position. First, when aligning the index marks in Step7, listen for pressure building inside the combustion chamber. Indicating that the piston is moving to TDC on its compression stroke. Second, view the gauge on the leak down tester when turning the engine. As the piston moves toward TDC on its compression stroke, compression building inside the combustion chamber may cause the gauge needle to move slightly. If the crankshaft is 360°off, these indicators will not be present.

NOTE

The decompress or mechanism will click loudly once during each crankshaft revolution. This is normal.

7. Use hex socket on the primary drive gear mounting bolt and turn the crankshaft clockwise and align the TDC mark on the flywheel with the index mark on the left crankcase cover Remove the hex socket from the primary drive gear.
8. Perform the following to lock the transmission so the engine remains at TDC on its compression stroke when performing the leak down test:

WARNING

Do not attempt to lock the engine by trying to use a tool to hold the Allen bolt on the end of the

GENERAL INFORMATION

crankshaft. Once the combustion chamber becomes pressurized, any crankshaft movement can throw the tool away from the engine under considerable force, attempting to hold the tool can cause serious injury. Engine damage may also occur to the crankshaft or right crankcase cover. Lock the engine as described in this procedure.

- a. Turn the drive sprocket by hand and shift the transmission into top gear with the shift pedal.
 - b. Mount a holding tool or equivalent onto the drive sprocket. Use a wooden block and clamp to hold the holding tool so it cannot move when the combustion chamber becomes pressurized.
 - c. Check that the TDC marks are still aligned as described in Step7, If not, turn the crankshaft as required, then relock the holding tool in position.
9. Remove the radiator cap and the oil filler cap.
10. Perform a cylinder leak down test by applying air pressure to the combustion chamber. Follow the manufacturer's instructions while reading the percent of leakage on the gauge. Listen for air leaking while noting the following:

NOTE

Because of play in the transmission gears, it is unlikely the engine will stay at TDC on the first try. If the crankshaft turns, reposition the countershaft slightly and then relock it in position with the holding tool. After several attempts, you will get a feel of the transmission play and know what direction the countershaft should be turned and locked.

NOTE

If a large amount of air escapes from the exhaust pipe or through the throttle, the air is leaking through an open valve. Check the index mark to make sure the engine is at TDC on the compression stroke. If the engine is remaining at TDC but there is still a large amount of air escaping from the engine, the crankshaft is off one revolution. Turn the engine 360° and realign the TDC mark as described in Step 7, then relock it as described in Step 8.

- a. Air leaking through the exhaust pipe indicates a leaking exhaust valve.
- b. Air leaking through the throttle indicates a leaking intake valve.
- c. Air leaking through both the intake and exhaust valves indicates the engine is not set at TDC on its compression stroke.
- d. Air leaking through the coolant filler neck indicates a leaking cylinder head gasket or a cracked cylinder head or cylinder liner.

GENERAL INFORMATION

- e. Air leaking through the oil filler hole indicates the rings are not sealing properly in the bore.
- 11. If the cylinder leak down is 10 percent or higher, further service is required.
- 12. Disconnect the test equipment and install all the parts previously removed.

ELECTRICAL TESTING

This section describes basic electrical testing and test equipment use.

Preliminary Checks and Precautions

Refer to the color wiring diagrams at the end of the manual for component and connector identification; Use the wiring diagrams to determine how the circuit should work by tracing the current paths from the power source through the circuit components to ground. Also, check any circuits that share the same fuse (if used), ground or switch. If the other circuits work properly and the shared wiring is good, the cause must be in the wiring used only by the suspect circuit. If all related circuits are faulty at the same time, the probable cause is a poor ground connection or a blown fuse (if used).

As with all troubleshooting procedures, analyze typical symptoms in a systematic manner. Never assume any thing and do not overlook the obvious like a blown fuse or an electrical connector that has separated. Test the simplest and most obvious items first and try to make tests at easily accessible points on the ATV.

Before starting any electrical troubleshooting, perform the following:

1. Check the fuse if the fuse is blown, replace it.
2. Inspect the battery. Make sure it is fully charged, and the battery leads are clean and securely attached to the battery terminals.
3. Disconnect each electrical connector in the suspect circuit and make sure there are no bent terminals in the electrical connector
4. Make sure the terminals on the end of each wire are pushed all the way into the connector. If not. Carefully push them in with a narrow blade screwdriver
5. Check the wires where they connect to the terminals for damage
6. Make sure all terminals within the connector are clean and free of corrosion. Clean them. If necessary. And pack the connectors with dielectric grease
7. Push the connectors with dielectric grease. The connectors are fully engaged and locked together
8. Never pull the electrical wires when disconnecting an electrical connector-pull only on the connector

Intermittent Problems

Intermittent problems are problems that do not occur all the time and can be difficult to locate. For example. When a problem only occurs when the ATV is ridden over rough roads (vibration) or in wet conditions (water penetration). It is intermit-ten. To locate and repair intermittent problems. Simulate the condition when testing the compo-nets. Note the following:

GENERAL INFORMATION

1. Vibration---This is a common problem with loose or damaged electrical connectors
 - a. Perform a continuity test as described in the appropriate service procedure. Or under *Continuity Test* in this section
 - b. Lightly pull or wiggle the connectors while repeating the test. Do the same when checking the wiring harness and individual components. especially where the wires enter a housing or connector
 - c. A change in meter readings indicates a poor connection. Fine and repair the problem or replace the part. Check for wires with cracked or broken insulation

NOTE

An analog ohmmeter is useful when making this type of test. Slight needle movements are apparent when indicating a loose connection

2. Heat – This is another common problem with connectors or plugs that have loose or poor connections. As these connections heat up. The connection or joint expands and separates. Causing an open circuit. Other heat related problem occur when a component creates its own heat as it starts to fail or go bad
 - a. Troubleshoot the problem to help isolate the problem or area
 - b. To check a connector. Perform a continuity test as described in the appropriate service procedure. Or under *Continuity test* in this chapter. Then repeat the test while heating the ground. If the lamp comes on. The problem is the connection between the lamp and Connector with a heat gun or hair dryer. If the meter reading was normal (continuity) when the connector was cold, then fluctuated or read infinity when heat was applied, the connection is bad.
 - c. To check a component, wait until the engine is cold, then start and run the engine. Note operational differences when the engine is cold and hot.
 - d. If the engine does not start, isolate and remove the component. First test it at room temperature, and then after heating it with a hair dryer. A change in meter readings indicates a temperature problem.

CAUTION

A heat gun or hair dryer will quickly raise the heat of the component being tested. Do not apply heat directly to the ICM or use heat in excess of 60°C (140°F) on any electrical component. If available, monitor heat with an infrared thermometer.

3. Water—when this problem occurs in wet conditions, or in areas with high humidity, start and run the engine in a dry area. Then, with the engine running, spray water related problems repair themselves after the component becomes hot enough to dry itself.

Electrical component replacement

GENERAL INFORMATION

Most ATV dealerships and parts suppliers will not accept the return of any electrical part. If you cannot determine the exact cause of any electrical system malfunction. If you purchase a new electrical component(s), install it, and then find that the system still does not work properly, you will probably be unable to return the unit for a refund.

Consider any test results carefully before replacing a component that tests only slightly out of specification, especially resistance. A number of variables can affect test results dramatically. These include: the testing meter's internal circuitry, ambient temperature and conditions under which the machine has been operated. All instructions and specifications have been for accuracy: however. Successful test results depend to a great degree upon individual accuracy.

Test Equipment

A test light can be constructed from a 12-volt light bulb with a pair of test leads carefully soldered to the bulb. To check for battery voltage in a circuit, attach one lead to ground and the other lead to various points along the circuit. The bulb lights when battery voltage is present.

A voltmeter is used in the same manner as the test light to find out if battery voltage is present in any given circuit. The voltmeter, unlike the test light, also indicates how much voltage is present at each test point. When using a voltmeter, attach the positive lead to the component or wire to be checked and the negative lead to a good ground.

Ammeter

An ammeter measures the flow of current (amps) in a circuit when connected in series in a circuit, the ammeter determines if current is flowing through the circuit and if that current flow is excessive because of a short in the circuit. Current flow is often referred to as current draw. Comparing actual current draw in the circuit or component to the manufacturer's specified current draw provides useful diagnostic information.

Self-powered test light

A self-powered test light can be constructed from a 12-volt light bulb, a pair of test leads and a 12-volt battery. When the test leads are touched together, the light bulb should go on.

Use a self-powered test light as follows:

1. Touch the test leads together to make sure the light bulb goes on. If not, correct the problem before using it in a test procedure.
2. Select two points within the circuit where there should be continuity.
3. Attach one lead of the self-powered test light to each point.
4. If there is continuity, the self-powered test light bulb will come on.
5. If there is no continuity, the self-powered test light bulb will not come on, indicating an open circuit.

Ohmmeter

GENERAL INFORMATION

An ohmmeter measures the resistance (in ohms) to current flow in a circuit or component. Like the self-powered test light, an ohmmeter contains its own power source and should not be connected to a live circuit.

Ohmmeter may be analog type (needle scale) or digital type (LCD or LED readout). Both types of ohmmeter have a switch that allows the user to select different ranges of resistance for accurate readings. The analog ohmmeter also has a set-adjust control which is used to zero or calibrate the meter (digital ohmmeters do not require calibration).

An ohmmeter is used by connecting its test leads to the terminals or leads of the circuit or component to be tested. If an analog meter is used, it must be calibrated by touching the test leads together and turning the set-adjust knob until the meter needle reads zero. When the leads are uncrossed, the needle reads zero. When the leads are uncrossed, the needle should move to the other end of the scale indicating infinite resistance.

During a continuity test, a reading of infinity indicates that there is an open in the circuit or component. A reading of zero indicates continuity, that is, there is no measurable resistance in the meter needle falls between these two ends of the scale, this indicates the actual resistance, multiply the meter reading by the ohmmeter scale. For example, a meter reading of 5 multiplied by the R×100 scale is 5000 ohms of resistance.

CAUTION

Never connect an ohmmeter to a circuit which has power applied to it. Always disconnect the battery negative lead before using an ohmmeter.

Jumper wire

A jumper wire is a simple way to bypass a potential problem and isolate it to a particular point in a circuit. If a faulty circuit works properly with a jumper wire installed, an open exists between the two jumper points in the circuit.

To troubleshoot with a jumper wire, first use the wire to determine if the problem is on the ground side or the load side of a device. Test the ground by connecting a jumper between the lamp and a good ground. If the lamp does not come on with the jumper installed. The lamp's connection to ground is good so the problem is between the lamp and the power source.

To isolate the problem. Connect the jumper between the battery and the lamp. If it comes on. The problem is between these two points. Next. Connect the jumper between the battery and the fuse side of the switch. If the lamp comes on. The switch is good. By successively moving the jumper from one point to another. The problem can be isolated to a particular place in the circuit

Pay attention to the following when using a jumper wire:

1. Make sure the jumper wire gauge (thickness) is the same as that used in the circuit being tested. Smaller gauge wire will rapidly overheat and could melt
2. Install insulated boots over alligator clips. This prevents accidental grounding. Sparks or possible shock when working in cramped quarters
3. Jumper wires are temporary test measures only. Do not leave a jumper wire installed as a

GENERAL INFORMATION

permanent solution. This creates a severe fire hazard that could easily lead to complete loss off the motorcycle

4. When using a jumper wire always install an inline fuse/fuse holder (available at most auto supply stores or electronic supply stores) to the jumper wire. Never use a jumper wire across any load (a component that is connected and turned on). This would result in a direct short and will blow the fuse(s)

Test Procedures

Voltage test

Unless otherwise specified. Make all voltage tests with the electrical connectors still connected. Insert the test leads into the backside of the connector and make sure the test lead touches the electrical wire or metal terminal within the connector housing. If the test lead only touches the wire insulation. There will be a false reading

Always check both sides of the connector as one side may be loose or corroded. Thus preventing electrical flow through the connector. This type of test can be performed with a test or a voltmeter. A voltmeter gives the best results

NOTE

If using a test light. It does not make any difference which test lead is attached to ground

1. Attach the voltmeter negative test lead to a good ground (bare metal). Make sure the part used for ground is not insulated with a rubber gasket or rubber grommet
2. Attach the voltmeter positive test lead to the point to be tested
3. Turn the ignition switch on. If using a test light. The test light will come on if voltage is present. If using a voltmeter. Note the voltage reading. The reading should be within 1 volt of battery voltage. If the voltage is less. There is a problem in the circuit

Voltage drop test

The wires. Cables. Connectors and switches in an electrical circuit are designed to carry current with low resistance. This ensures that current can flow through the circuit with a minimum loss of voltage. Voltage drop indicates where there is resistance in a circuit. A higher than normal amount of resistance in a circuit decreases the flow of current and cause the voltage to drop between the source and destination in the circuit.

Because resistance causes voltage to drop. A voltmeter is used to measure voltage drop when current is running through the circuit. If the circuit has no resistance. There is no voltage drop so the voltmeter indicates 0 volts. The greater the resistance in a circuit. The greater the voltage drop reading.

To perform a voltage drop:

1. Connect the positive meter test lead to the electrical source (where electricity is coming from).
2. Connect the voltmeter negative test lead to the electrical load (where the electricity is going).

GENERAL INFORMATION

3. If necessary, activate the component(s) in the circuit. For example. If checking the voltage in the starter circuit, it would be necessary to push the starter button.
4. Read the voltage drop (difference in voltage between the source and destination) on the voltmeter. Note the following:
 - a. The voltmeter should indicate 0 volts. If there is a drop of 0.5 volts or more. There is a problem within the circuit. A voltage drop reading of 12 volts indicates an open in the circuit.
 - b. A voltage drop of 1 or more volts indicates that a circuit has excessive resistance.
 - c. For example, consider a starting problem where the battery is fully charged but the starter motor turns over slowly. Voltage drop would be the difference in the voltage at the batter (source) and the voltage at the starter (destination) as the engine is being started (current is flowing through the batter cables). A corroded battery cable would cause a high voltage drop (high resistance) and slow engine cranking.
 - d. Common sources of voltage drop are loose or contaminated connectors and poor ground connections.

Peak voltage test

Peak voltage tests check the voltage output of the ignition coil and ignition pulse generator at normal cranking speed. These tests make it possible to identify ignition system problems quickly and accurately.

Peak voltage tests require a peak voltage adapter or tester. See Chapter Ten, Ignition System Testing.

Continuity Test

A continuity test is used to determine the integrity of a circuit, wire or component. A circuit has continuity if it forms a complete circuit, that is, if there are no opens in either the electrical wires or components within the circuit. A circuit with an open. On the other hand, has no continuity.

This type of test can be performed with a self-powered test light or an ohmmeter. An ohmmeter gives the best results. If using an analog ohmmeter, calibrate the meter by touching the leads together and turning the calibration knob until the meter reads zero.

1. Disconnect the negative battery cable.
2. Attach one test lead (test light or ohmmeter) to one end of the part of the circuit to be tested.
3. Attach the other test lead to the other end of the part or the circuit to be tested.
4. The self-powered test lead comes on if there is continuity. An ohmmeter reads 0 or very low resistance if there is continuity. A reading of infinite resistance if there is continuity. A reading of infinite resistance indicates no continuity, the circuit is open.

Testing for a short with a self-powered test light or ohmmeter

1. Disconnect the negative battery cable.
2. Remove the blown fuse.
3. Connect one test lead of the test light or ohmmeter to the load side (battery side) of the fuse

GENERAL INFORMATION

terminal in the starter relay.

4. Connect the other test lead to a good ground (bare metal). Make sure the part used for a ground is not insulated with a rubber gasket or rubber grommet.
5. With the self-powered test light or ohmmeter attached to the fuse terminal and ground, wiggle the wiring harness relating to the suspect circuit at various intervals. Start next to the fuse terminals and work away from the fuse terminal. Watch the self-powered test light or ohmmeter while progressing along the harness.
6. If the test light blinks or the needle on the ohmmeter moves, there is a short-to-ground at that point in the harness.

Testing for a short with a test light or voltmeter

1. Remove the blown fuse.
2. Connect the test light or voltmeter across the fuse terminals in the starter relay. Turn the ignition switch ON and check for battery voltage.
3. With the test light or voltmeter attached to the fuse terminals, wiggle the wiring harness relating to the suspect circuit at various intervals. Start next to the fuse terminal and work systematically away from the fuse terminal. Watch the test light or voltmeter while progressing along the harness.
4. If the test light blinks or if the needle on the voltmeter moves, there is a short-to-ground at that point in the harness.

BRAKE SYSTEM

The front and rear brake units are critical to riding performance and safety. Inspect the front and rear brakes frequently and repair any problem immediately. When replacing or refilling the brake fluid, use only DOT 4 brake fluid from a closed container.

Always check the brake operation before riding the motorcycle.

Soft or Spongy Brake Lever or Pedal

Operate the front brake lever or rear brake pedal and check to see if the lever travel distance increases. If the lever travel does increase while being operated, or feels soft or spongy, there may be air in the brake line. In this condition, the brake system is not capable of producing sufficient brake force. When there is an increase in lever or pedal travel or when the brake feels soft or spongy, check the following possible causes:

1. Air in system.

WARNING

If the fluid level drops too low, air can enter the hydraulic system through the master cylinder. Air can also enter the system from loose or damaged hose fittings. Air in the hydraulic system causes

GENERAL INFORMATION

a soft or spongy brake lever action. This condition is noticeable and reduces brake performance. When it is suspected that air has entered the hydraulic system, flush the brake system and bleed the brakes as described in Chapter Fifteen.

2. Low brake fluid level.

WARNING

As the brake pads wear, the brake fluid level in the master cylinder reservoir drops. Whenever adding brake fluid to the reservoir, visually check the brake pads for wear. If it does not appear that there is an increase in pad wear, check the brake hoses, lines and banjo bolts for leaks.

3. Leak in the brake system.
4. Contaminated brake fluid.
5. Plugged brake fluid passages.
6. Damaged brake lever or pedal assembly.
7. Worn or damaged brake pads.
8. Warped brake disc.
9. Contaminated brake pads and disc.

WARNING

A leaking fork seal can allow oil to contaminate the brake pads and disc.

10. Worn or damaged master cylinder cups and/or cylinder bore.
11. Worn or damaged brake caliper piston seals.
12. Contaminated master cylinder assembly.
13. Contaminated brake caliper assembly.
14. Brake caliper not sliding correctly on slide pins.
15. Sticking master cylinder piston assembly.
16. Sticking brake caliper pistons.

Brake Drag

When the brakes drag, the brake pads are not capable of moving away from the brake disc when the brake lever or pedal is released. Any of the following causes, if they occur, would prevent correct brake pad movement and cause brake drag.

1. Warped or damaged brake disc.
2. Brake caliper not sliding correctly on slide pins.

GENERAL INFORMATION

3. Sticking or damaged brake caliper pistons.
4. Contaminated brake pads and disc.
5. Plugged master cylinder port.
6. Contaminated brake fluid and hydraulic passages.
7. Restricted brake hose joint.
8. Loose brake disc mounting bolts.
9. Damaged or misaligned wheel.
10. Incorrect wheel alignment.
11. Incorrectly installed brake caliper.
12. Damaged front or rear wheel.

Hard Brake Lever or Pedal Operation

When applying the brakes and there is sufficient brake performance but the operation of brake lever feels excessively hard, check for the following possible causes:

1. Clogged brake hydraulic system.
2. Sticking caliper piston.
3. Sticking master cylinder piston.
4. Glazed or worn brake pads.
5. Mismatched brake pads.
6. Damaged front brake lever.
7. Damaged rear brake pedal.
8. Brake caliper not sliding correctly on slide pins.
9. Worn or damaged brake caliper seals.

Brake Grabs

1. Damaged brake pad pin bolt. Look for steps or cracks along the pad pin bolt surface.
2. Contaminated brake pads and disc.
3. Incorrect wheel alignment.
4. Warped brake disc.
5. Loose brake disc mounting bolts.
6. Brake caliper not sliding correctly on slide pins.
7. Mismatched brake pads.
8. Damaged wheel bearings.

Brake Squeal or Chatter

1. Contaminated brake pads and disc.
2. Incorrectly installed brake caliper.
3. Warped brake disc.
4. Incorrect wheel alignment.
5. Mismatched brake pads.

GENERAL INFORMATION

6. Incorrectly installed brake pads.
7. Damaged or missing brake pad spring or pad retainer.

Leaking Brake Caliper

1. Damaged dust and piston seals.
2. Damaged cylinder bore.
3. Loose caliper body bolts.
4. Loose banjo bolt.
5. Damaged banjo bolt washers.
6. Damaged banjo bolt threads in caliper body.

Leaking Master Cylinder

1. Damaged piston secondary seal.
2. Damaged piston snap ring/ snap ring groove.
3. Worn or damaged master cylinder bore.
4. Loose banjo bolt washers.
5. Damaged banjo bolt washers.
6. Damaged banjo bolt threads in master cylinder body.
7. Loose or damaged reservoir cap.

SPECIFICATIONS

SPECIFICATIONS

HOW TO CONVERSION TABLE OF UNIT

(1) How to use conversion table

All the specified documents in this manual are taken SI and Metric as unit. With the following conversion table, metric unit could be converted into imperial unit.

Sample:

METRIC	MULTIPLY	IMPERIAL
mm	0.03937	=in
2mm ×	0.03937	=0.08in

Conversion table

Conversion between metric and imperial			
	Know unit	Multiply	Product
Torque	m·kg	7.233	ft·lb
	m·kg	86.794	in·lb
	cm·kg	0.0723	ft·lb
	cm·kg	0.8679	in·lb
Weight	kg	2.205	lb
	g	0.03527	oz
Length	km/hr	0.6214	mph
	km	0.6214	mi
	m	3.281	ft
	m	1.094	yd
	cm	0.3937	in
	mm	0.03937	in
Volume/capacity	cc (cm ³)	0.03527	oz (IMP liq.)
	cc (cm ³)	0.06102	cu·in
	lit (liter)	0.8799	qt (IMP liq.)
	lit (liter)	0.2199	gal (IMP liq.)
Others	kg/mm	55.997	lb/in
	kg/cm ²	14.2234	psi (lb/in ²)
	Centigrade	9/5 (°C) +32	Fahrenheit (°F)

(2) Definition of unit

Unit	Read	Definition	Measurement
mm	Millimetre	1 mm=10 ⁻³ Meter	Length
cm	Centimetre	1 cm =10 ⁻² Meter	Length
kg	Kilogram	1 kg =10 ³ Gram	Weight
N	Newton	1N=1 kg×meter/second ²	Force
N.m	Newton meter	1 Nm=1Newton×1meter	Torque
kgf.m	Meter Kilogram	1 kgf.m =1Meter×1kgf	Torque
Pa	Pascal	1 Pa=1Newton/1meter ²	Pressure
N/mm	Newton per millimeter	1 N/mm =1Newton/ millimeter	Rigid of spring
L	Litre	—	Volume of capacity
cm ³	Cubic centimeter	—	
r/min	Revolutions per minute	—	Rotational speed

SPECIFICATIONS

GEBERAR SPECIFICATIONS

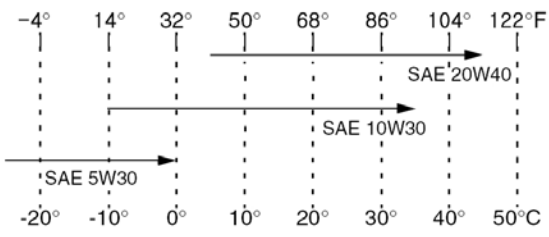
Item	Standard
Dimensions : Overall length Overall width Overall height Seat height Wheelbase Minimum ground clearance Minimum turning radius	2,250 mm (88.6in) 1,210 mm (47.6 in) 1,225mm (48.2in) 880 mm (34.6 in) 1,365 mm (53.7in) 260 mm (10.2 in) 3200mm (126.0 in)
Basic weight : With oil and full fuel tank	362 kg (798.1 lb)
Engine : Engine type Cylinder arrangement Displacement Bore×stroke Compression ratio Starting system Lubrication system	4-stroke, Water cool Forward-inclined single cylinder 686cm ³ 102×84.0mm (4.02×3.31in) 9.2:1 Electric starter and recoil starter Wet sump
Oil type or grade: Engine oil  Final gear oil Differential gear oil	API service SE,SF,SG type or higher SAE80 API GL-4 Hypoid gear oil SAE80 API GL-5 Hypoid gear oil
Oil capacity: Engine oil Periodic oil change With oil filter replacement Total amount Final gear case oil Periodic oil change Total amount Differential gear case oil Periodic oil change Total amount	1.90 L (1.67Imp qt, 2.01 US qt) 2.10 L (1.85 Imp qt, 2.22 US qt) 2.40 L (2.11 Imp qt, 2.54 US qt) 0.25 L (0.22 Imp qt, 0.26 US qt) 0.28 L (0.25 Imp qt, 0.30 US qt) 0.32 L (0.28 Imp qt, 0.34 US qt) 0.33 L (0.29 Imp qt, 0.35 US qt)

SPECIFICATIONS

Item	Standard
Air filter	Wet type element
Fuel Type Fuel tank capacity	Unleaded gasoline only 13.0L (2.86 Imp gal, 3.43 US gal)
Throttle Type/quantity	D46-4 / 1
Spark plug Type/manufacturer Spark plug gap	DCPR7E / 1 (NGK) 0.8-0.9 mm (0.031-0.035 in)
Clutch type	Wet ,centrifugal automatic
Transmission Primary reduction system Secondary reduction system Secondary reduction ratio Transmission type Operation Single speed automatic Sub transmission ratio Reverse gear	V-belt Shaft drive 16.339~2.475 V-belt automatic Right hand operation 0.75~2.45 5.3595 (30/17×41/21×24/18) 3.2230 (26/21×41/21×24/18) 3.8282 (25/17×41/21×24/18)
Chassis Frame type Camber angle Trail Toe-in	Steel tube frame 5° 26.0mm (1.02 in) 0~10 mm (0.00~0.39 in)
Tire Type Size Pressure of front wheel Pressure of rear wheel	Tubeless 25×8-12 25×10-12 70kpa 70kpa
Brake I : Front brake Rear brake II : Front brake Rear brake	Type Operation Type Operation Type Operation Type Operation Type Operation Type Operation Type Operation Type Operation
	Dual disc brake Right hand operation Single disc brake Left hand and right foot operation Dual disc brake Right hand operation Dual disc brake Left hand and right foot operation

SPECIFICATIONS

Item	Standard
Suspension Front suspension Rear suspension Shock absorber Front shock absorber Rear shock absorber Wheel travel Front wheel travel Rear wheel travel	Double wishbone Double wishbone Coil spring/oil damper Coil spring/oil damper 185 mm (7.3 in) 185 mm (7.3 in)
Electrical Ignition system Generator system Battery type Battery capacity	EFI A.C. magneto MS12-19CL-BS 12 V, 21Ah
Headlight type Bulb wattage × quantity Headlight Tail/brake light Neutral Reverse Coolant temperature Parking brake Four-wheel drive Differential gear lock	Krypton bulb 12V30.3W/35W × 2 12V5W/21W × 2 LED LED LED LED LED LED

SPECIFICATIONS

ENGINE SPECIFICATIONS

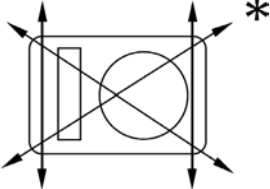
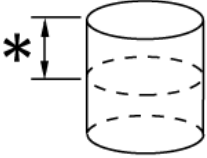
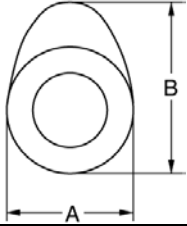
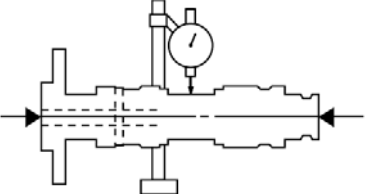
Item	Standard	Limit
Cylinder head Warp limit * 	---	0.03 mm (0.0012 in)
Cylinder Bore size Measuring point * 	100.005 ~ 100.055 mm (3.9372 ~ 3.9392 in) 50 mm (1.97 in)	100.10 mm (3.9410 in) ---
Camshaft Drive method Cam dimensions 	Chain drive (Left)	---
Intake “A” “B” Exhaust “A” “B”	30.06 ~ 30.16 mm (1.1835 ~ 1.1874 in) 35.69 ~ 35.79 mm (1.4051 ~ 1.4091 in) 30.11 ~ 30.21 mm (1.1854 ~ 1.1894 in) 36.50 ~ 36.60 mm (1.4370 ~ 1.4409 in)	(1.1795 in) 29.96 mm 35.59 mm (1.4012 in) 30.01 mm (1.1815 in) 36.40 mm (1.4331 in)
Camshaft runout limit 	---	0.03 mm (0.0012 in)

SPECIFICATIONS

Item	Standard	Limit	
Cam chain			
No. of links	126		
Cam chain adjustment method	Automatic		
Rocker arm/rocker arm shaft			
Rocker arm inside diameter	12.000 ~ 12.018 mm (0.4724 ~ 0.4731 in)		
Shaft outside diameter	11.976 ~ 11.991 mm (0.4715 ~ 0.4721 in)	----	
Arm-to-shaft clearance	0.009 ~ 0.042 mm (0.0004 ~ 0.0017 in)	----	
Valve, valve seat, valve guide			
Valve clearance (cold) IN	0.10 ~ 0.15 mm (0.0039 ~ 0.0059 in)	----	
EX	0.15 ~ 0.20 mm (0.0059 ~ 0.0079 in)	----	
Valve dimensions			
head diameter	face width	seat width	margin thickness
"A" head diameter	IN	29.9 ~ 30.1 mm (1.1772 ~ 1.1850 in)	----
	EX	31.9 ~ 32.1 mm (1.2559 ~ 1.2638 in)	----
"B" face width	IN	2.25 mm (0.0900 in)	----
	EX	2.26 mm (0.0890 in)	----
"C" seat width	IN	0.9 ~ 1.1 mm (0.0354 ~ 0.0433 in)	1.6 mm (0.0630 in)
	EX	0.9 ~ 1.1 mm (0.0354 ~ 0.0433 in)	1.6 mm (0.0630 in)
"D" margin thickness	IN	0.85 ~ 1.15 mm (0.0335 ~ 0.0453 in)	----
	EX	0.85 ~ 1.15 mm (0.0335 ~ 0.0453 in)	----
Stem outside diameter	IN	5.975 ~ 5.990 mm (0.2352 ~ 0.2358 in)	5.945 mm (0.2341 in)
	EX	5.960 ~ 5.975 mm (0.2346 ~ 0.2352 in)	5.930 mm (0.2335 in)
Guide inside diameter	IN	6.000 ~ 6.012 mm (0.2362 ~ 0.2367 in)	6.050 mm (0.2559 in)
	EX	6.000 ~ 6.012 mm (0.2362 ~ 0.2367 in)	6.050 mm (0.2559 in)

SPECIFICATIONS

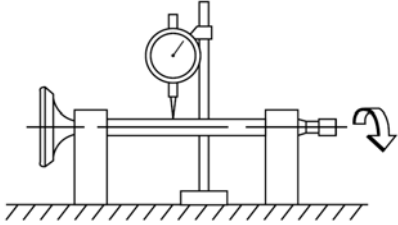
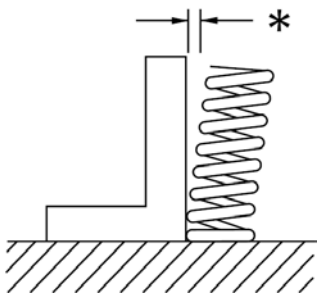
Item	Standard	Limit
Stem-to-guide clearance	IN 0.010 ~ 0.037 mm (0.0004 ~ 0.0015 in)	0.08 mm (0.0031 in)
	EX 0.025 ~ 0.052 mm (0.0010 ~ 0.0020 in)	0.10 mm (0.0039 in)
Stem runout limit	----	0.01 mm (0.0004 in)
		
Valve seat width	IN 0.9 ~ 1.1 mm (0.0354 ~ 0.0433 in)	----
	EX 0.9 ~ 1.1 mm (0.0354 ~ 0.0433 in)	----
Valve spring		
Inner spring		
Free length	IN 32.63 mm (1.28 in)	31.0 mm
	EX 36.46 mm(1.44 in)	(1.22 in)
Set length (valve closed)	IN 27.5 mm (1.08 in)	34.6 mm
	EX 31.0 mm(1.22 in)	(1.36 in)
Compressed pressure (installed)	IN 100.0 ~ 115.7 N (10.20 ~ 11.80 kg, 22.49 ~ 26.01 lb)	----
	EX 120.6 ~ 138.3 N (12.30 ~ 14.10 kg, 27.12 ~ 31.09 lb)	----
Tilt limit *	IN ----	2.5°/1.4 mm (2.5°/0.055 in)
	EX ----	2.5°/1.6 mm (2.5°/0.063 in)
		
Direction of winding (top view)	IN Clockwise	----
	EX Clockwise	----

SPECIFICATIONS

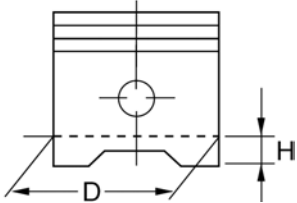
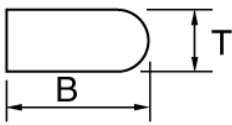
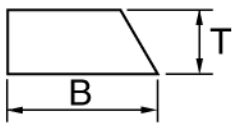
Item	Standard	Limit
Piston		
Piston to cylinder clearance	0.050 ~ 0.070 mm (0.0020 ~ 0.0028 in)	0.15 mm (0.0059 in)
Piston size "D"	99.945 ~ 99.995 mm (3.9348 ~ 3.9368 in)	----
		
Measuring point "H"	2.5 mm (0.10 in)	----
Piston off-set	1.0 mm(0.0394 in)	----
Off-set direction	Intake side	22.045 mm
Piston pin bore inside diameter	22.004 ~ 22.015 mm (0.8663 ~ 0.8667 in)	(0.8679 in)
Piston pin outside diameter	21.991 ~ 22.000 mm (0.8658 ~ 0.8661 in)	21.971 mm (0.8650 in)
Piston rings		
Top ring		
		
Type	Barrel	----
Dimensions (B× T)	1.2 × 3.8 mm (0.0472 × 0.1496 in)	----
End gap (installed)	0.30 ~ 0.45 mm (0.0118 ~ 0.0177 in)	0.70 mm (0.0276 in)
Side clearance (installed)	0.04 ~ 0.08 mm (0.0016 ~ 0.0031 in)	0.13 mm (0.0051 in)
2nd ring		
		
Type	Taper	----
Dimensions (B × T)	1.2×4.0 mm (0.0472 ×0.1575 in)	----
End gap (installed)	0.30 ~ 0.45 mm (0.0118 ~ 0.0177 in)	0.80 mm (0.0315 in)
Side clearance	0.03 ~ 0.07 mm (0.0012 ~ 0.0028 in)	0.13 mm (0.0051 in)

SPECIFICATIONS

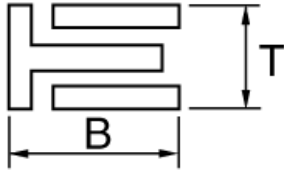
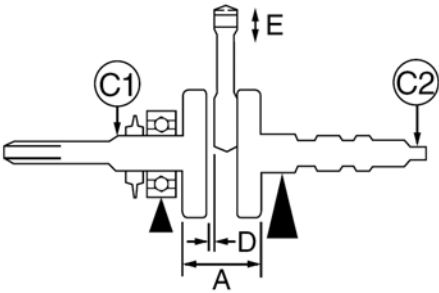
Item	Standard	Limit
<p>Oil ring</p>  <p>Dimensions (B×T)</p> <p>End gap (installed)</p> <p>Side clearance</p>	<p>2.5×3.4 mm (0.0984×0.1339 in)</p> <p>0.20 ~ 0.70 mm (0.0079 ~ 0.0276 in)</p> <p>0.06 ~ 0.15 mm (0.0024 ~ 0.0059 in)</p>	<p>----</p> <p>----</p> <p>----</p>
<p>Crankshaft</p>  <p>Crank width "A"</p> <p>Runout limit C1 C2</p> <p>Big end side clearance "D"</p> <p>Big end radial clearance "E"</p>	<p>74.95 ~ 75.00 mm (2.9508 ~ 2.9528 in)</p> <p>----</p> <p>----</p> <p>0.35 ~ 0.65 mm (0.0138 ~ 0.0256 in)</p> <p>0.010 ~ 0.025 mm (0.0004 ~ 0.0010 in)</p>	<p>----</p> <p>0.03 mm (0.0012 in)</p> <p>0.03 mm (0.0012 in)</p> <p>1.0 mm (0.0394 in)</p> <p>----</p>
<p>Balancer</p> <p>Balancer drive method</p>	<p>Gear</p>	<p>----</p>
<p>Automatic centrifugal clutch</p> <p>Clutch shoe thickness</p> <p>Clutch-in revolution</p> <p>Clutch-stall revolution</p>	<p>1.5 mm (0.06 in)</p> <p>1,900 ~ 2,300 r/min</p> <p>3,350 ~ 3,850 r/min</p>	<p>1.0 mm (0.04 in)</p> <p>----</p> <p>----</p>

SPECIFICATIONS

Item	Standard	Limit
Transmission		
Main axle deflection limit	----	0.06 mm (0.0024 in)
Drive axle deflection limit	----	0.06 mm (0.0024 in)
Shifter		
Shifter type	Shift drum and guide bar	----
Air filter oil grade		
	Engine oil	----
Oil pump		
Oil filter type	Foam	----
Oil pump type	Trochoid	----
Tip clearance	0.15 mm (0.0059 in)	0.23 mm (0.0091 in)
Side clearance	0.03 ~ 0.10 mm (0.0012 ~ 0.0039 in)	0.17 mm (0.0067 in)
Body clearance	0.09 ~ 0.17 mm (0.0035 ~ 0.0067 in)	0.24 mm (0.0094 in)
Bypass valve setting pressure	441.0 ~ 637.0 Kpa (4.41 ~ 6.37 kg/cm ² , 62.7 ~ 90.6 psi)	----
Oil pressure (hot)	65 Kpa (0.65 kg/cm ² , 9.2 psi) at 1,500 r/min	----
Pressure check location	Cylinder head	----
Water pump		
Type	Single-suction centrifugal pump	----
Reduction ratio	32/31 (1.032)	----
Shaft drive		
Middle gear backlash	0.1 ~ 0.3 mm (0.004 ~ 0.012 in)	----
Final gear backlash	0.1 ~ 0.3 mm (0.004 ~ 0.012 in)	----
Differential gear backlash	0.05 ~ 0.25 mm (0.002 ~ 0.010 in)	----
Cooling system		
Radiator core		
Width	380 mm (14.96 in)	----
Height	238 mm (9.37 in)	----
Thickness	24 mm (0.94 in)	----
Radiator cap opening pressure	107.9 ~ 137.3 Kpa (1.079~1.373 kg /cm ² , 15.35~19.53 psi)	----
Radiator capacity (including all routes)	2.5 L (2.20 Imp qt, 2.64 US qt)	----
Coolant reservoir		
Capacity	0.35 L (0.31 Imp qt, 0.37 US qt)	----
From low to full level	0.20 L (0.15 Imp qt, 0.21 US qt)	----

SPECIFICATIONS

CHASSIS SPECIFICATIONS

Item	Standard	Limit
Steering system		
Type	Rack and pinion	----
Front suspension		
Shock absorber travel	108 mm (4.25 in)	----
Spring free length	313 mm (12.32 in)	----
Spring fitting length	247.9 mm (9.76 in)	----
Spring rate	19.4 N/mm(1.94 kg/mm, 108.6 lb/in)	----
Stroke	0 ~ 108 mm (0 ~ 4.25 in)	
Rear suspension		
Shock absorber travel	81 mm (3.19 in)	----
Spring free length	328 mm (12.91 in)	----
Spring fitting length	273.2 mm (10.76 in)	----
Spring rate	44.1 N/mm (4.41 kg/mm, 246.95 lb/in)	----
	117.7N/mm (11.77kg/mm, 659.08 lb/in)	----
Stroke	0 ~ 60 mm (0 ~ 2.36 in)	----
	60 ~ 81 mm (2.36 ~ 3.15 in)	----
Front wheel		
Type	Panel wheel	----
Rim size	12 ×6.0 AT	----
Rim material	Steel	----
Rim runout limit	radial	2.0 mm (0.08 in)
	lateral	2.0 mm (0.08 in)
Rear wheel		
Type	Panel wheel	----
Rim size	12×8.0 AT	----
Rim material	Steel	----
Rim runout limit	radial	2.0 mm (0.08 in)
	lateral	2.0 mm (0.08 in)
Brake lever and brake pedal		
Accelerator pedal free play	0 mm (0.0 in)	----
Brake pedal free play	0 mm (0.0 in)	----
Parking brake cable free play	2 ~ 3 mm (0.079 ~ 0.118 in)	----

SPECIFICATIONS

Item	Standard	Limit
Front disc brake		
Type	Dual	----
Disc outside diameter × thickness	200 × 3.5 mm (7.87 × 0.14 in)	----
Pad thickness inner	5.2 mm (0.20 in)	1.5 mm (0.06 in)
Pad thickness outer	5.2 mm (0.20 in)	1.5 mm (0.06 in)
Master cylinder inside diameter	17.4 mm (0.69 in)	----
Caliper cylinder inside diameter	27.0 mm (1.06 in)	----
Brake fluid type	DOT 4	
Rear disc brake		
Type	Single or Dual	----
Disc outside diameter × thickness	165.0 × 5.0 mm (6.50 × 0.20 in)	----
Pad thickness inner	5.6 mm	
Pad thickness outer	(0.22 in)	1.5 mm
Master cylinder inside diameter	5.6 mm	(0.06 in)
Caliper cylinder inside diameter	(0.22 in)	1.5
Brake fluid type	17.4 mm (0.69 in)	(0.06 in)
	32.0 mm (1.26 in)	----
	DOT 4	----

SPECIFICATIONS

ELECTRICAL SPECIFICATIONS

Item	Standard	Limit
Voltage	12 V	----
Ignition system		
Ignition timing (BTDC)	12°/ 1,500 r/min	----
Advancer type	ECU Digital type	----
Ignition coil		
Minimum spark gap	6 mm (0.24 in)	----
Primary winding resistance	0.18 ~ 0.28 Ωat 20 °C (68 °F)	----
Secondary winding resistance	6.32 ~ 9.48 kΩat 20 °C (68 °F)	----
Spark plug cap		
Resistance	5.0~5.5 kΩ	----
High voltage cap		
Resistance	4.5~5.0 kΩ	
Oxygen sensor		
type	25325359	
Charging system		
Nominal output	14 V 23 A at 5,000 r/min	----
Charging coil resistance/color	0.32 ~ 0.43Ωat 20 °C (68 °F)/White – White	----
Rectifier/regulator		
Regulator type	Semi conductor-short circuit	----
No load regulated voltage (DC)	14.1 ~ 14.9 V	----
Capacity	18 A	----
Withstand voltage	200 V	----
Battery		
Specific gravity	1.32	----
Circuit breaker		
Type	Fuse	----
Main fuse	30A×1	
Lighting system fuse	15 A×1	----
Ignition fuse	10 A×1	----
Auxiliary DC jack fuse	10 A×1	----
Four-wheel drive fuse	3 A×1	----
Signaling system fuse	10 A×1	----
Radiator fan		
Running rpm	2,950 r/min	

SPECIFICATIONS

Item	Standard	Limit
Electric starter system		
Type	Constant mesh type	----
Starter motor		
Output	0.8 kW	----
Armature coil resistance	0.025 ~ 0.035 Ω at 20 °C (68 °F)	----
Brush overall length	12.5 mm (0.49 in)	----
		5 mm(0.20 in)
Spring force	7.65 ~ 10.01 N (780 ~ 1,021 g, 27.5 ~ 36.0 oz)	----
Commutator diameter	28 mm (1.10 in)	
Mica undercut	0.7 mm (0.03 in)	27 mm(1.06 in)
Starter relay		
Amperage rating	180 A	----
Coil winding resistance	4.18 ~ 4.62 at 20 °C (68 °F)	-----

SPECIFICATIONS

TIGHTENING TORQUES

Engine tightening torques

Part to be tightened	Part name	Thread size	Q'ty	Tightening torque			Remarks
				Nm	m · kg	ft · lb	
Cylinder head	Bolt	M6	1	10	1.0	7.2	
	Bolt	M9	6	38	3.8	27	
Spark plug	—	M12	1	18	1.8	13	
Cylinder head (exhaust pipe)	Stud bolt	M8	4	15	1.5	11	
Cylinder head cover	Bolt	M6	17	10	1.0	7.2	
Tappet cover (exhaust)	—	M32	2	12	1.2	8.7	
Tappet cover (intake)	Bolt	M6	4	10	1.0	7.2	
Oil gallery bolt	—	M6	1	7	0.7	5.1	
Camshaft end cap	Bolt	M6	1	10	1.0	7.2	
Cylinder	Bolt	M6	2	10	1.0	7.2	
	Bolt	M10	4	42	4.2	30	
Balancer driven gear	Nut	M18	1	110	11.0	80	
Timing chain tensioner	Bolt	M6	2	10	1.0	7.2	
Timing chain tensioner cap	Bolt	M6	1	7	0.7	5.1	
Timing chain guide (intake side)	Bolt	M6	2	8	0.8	5.8	
Camshaft sprocket	Bolt	M7	2	20	2.0	14	
Rocker arm shaft stopper	Bolt	M6	2	10	1.0	7.2	
Valve adjusting locknut	—	M6	5	14	1.4	10	
Engine oil drain bolt	—	M14	1	30	3.0	22	
Oil filter cartridge union bolt	—	M20	1	63	6.3	4.6	
Oil filter cartridge	—	M20	1	17	1.7	12	
Oil pipe assembly	Bolt	M6	4	7	0.7	5.1	
Oil delivery pipe 1	Union Bolt	M8	2	18	1.8	13	
Oil delivery pipe 2	Union Bolt	M14	1	35	3.5	25	
Oil delivery pipe 3	Union Bolt	M10	1	20	2.0	14	
Oil delivery pipe 2 and oil delivery pipe 3	Union bolt	M14	1	35	3.5	25	
Relief valve assembly plate	Bolt	M6	2	10	1.0	7.2	
Oil strainer	Bolt	M6	1	10	1.0	7.2	
Oil pump assembly	Bolt	M6	3	10	1.0	7.2	
Oil cooler inlet pipe 1/oil cooler outlet pipe 1	Bolt	M6	2	7	0.7	5.1	
Oil cooler inlet pipe 1/oil cooler outlet pipe 1 clamp	Bolt	M6	1	7	0.7	5.1	
Oil cooler inlet pipe 2/oil cooler outlet pipe 2 clamp	Bolt	M6	2	7	0.7	5.1	
Intake manifold	Bolt	M6	4	10	1.0	7.2	

SPECIFICATIONS

Part to be tightened	Part name	Thread size	Q'ty	Tightening torque			Remarks
				Nm	m · kg	ft · lb	
Intake manifold screw clamp	—	M5	1	3	0.3	2.1	
	Bolt	M8	3	26	2.6	19	
	Bolt	M6	14	10	1.0	7.2	
Crankcase							
	Bolt	M6	1	10	1.0	7.2	
Bearing housing (clutch housing assembly)	Bolt	M6	1	10	1.0	7.2	
Air duct assembly 1 bracket	Bolt	M6	2	14	1.4	10	
Oil seal (engine cooling fan pulley) Retainer	Bolt	M5	2	7	0.7	5.1	
Drive belt case	Bolt	M6	9	10	1.0	7.2	
Drive belt cover	Bolt	M6	14	10	1.0	7.2	
Engine cooling fan	Bolt	M6	2	7	0.7	5.1	
Air shroud 1 and air shroud 2	Bolt	M6	4	10	1.0	7.2	
Air shroud 2 and A.C. magneto cover	Bolt	M6	4	10	1.0	7.2	
Engine cooling fan pulley	Bolt	M10	1	55	5.5	40	
Engine cooling fan air duct assembly	Bolt	M6	1	7	0.7	5.1	
Stator assembly	Screw	M6	3	7	0.7	5.1	
Pickup coil	Bolt	M5	2	7	0.7	5.1	
Stator lead holder	Bolt	M6	2	10	1.0	7.2	
A.C. magneto cover	Bolt	M6	12	10	1.0	7.2	
Starter clutch	Bolt	M8	3	30	3.0	22	
Clutch carrier assembly	Nut	M22	1	160	16.0	115	Stake
Clutch housing assembly	Bolt	M6	9	10	1.0	7.2	
Bearing retainer (middle drive shaft)	Screw	M8	4	29	2.9	21	
Middle drive pinion gear	Nut	M22	1	145	14.5	105	Stake
Middle drive shaft bearing housing	Bolt	M8	4	32	3.2	23	
Middle driven pinion gear bearing Retainer	Nut	M60	1	110	11.0	80	Left-hand threads
Universal joint yoke and middle driven pinion gear	Nut	M16	1	150	15.0	110	
Middle driven pinion gear bearing Housing	Bolt	M8	4	25	2.5	18	
Drive shaft coupling and middle driven shaft	Nut	M14	1	97	9.7	70	
Middle driven shaft bearing retainer	Nut	M55	1	80	8.0	58	Left-hand threads
Primary sheave assembly	Nut	M16	1	120	12.0	85	
Primary pulley sheave cap	Screw	M4	8	3	0.3	2.2	
Secondary sheave assembly	Nut	M16	1	100	10.0	72	
Secondary sheave spring retainer	Nut	M36	1	90	9.0	65	
Shift lever cover	Bolt	M6	4	10	1.0	7.2	

SPECIFICATIONS

Part to be tightened	Part name	Thread size	Q'ty	Tightening torque			Remarks
				Nm	m.kg	ft · lb	
Shift lever 2 assembly	Bolt	M6	1	14	1.4	10	Left-hand threads
Shift drum stopper	Bolt	M14	1	18	1.8	13	
Shift arm	Bolt	M6	1	14	1.4	10	
Shift rod locknut (select lever unit)	—	M8	1	15	1.5	11	
Shift rod locknut (shift arm side)	—	M8	1	15	1.5	11	
Select lever unit	Bolt	M8	3	15	1.5	11	
Plug (right crankcase)	—	M14	1	18	1.8	13	
Water pump assembly	Bolt	M6	2	10	1.0	7.2	
Water pump housing cover	Bolt	M6	2	12	1.2	8.7	
Coolant drain bolt	—	M6	1	10	1.0	7.2	
Coolant inlet joint	Bolt	M6	2	10	1.0	7.2	
Coolant outlet joint	Bolt	M6	2	10	1.0	7.2	
Air bleed bolt (coolant outlet joint)	—	M6	1	9	0.9	6.5	
Coolant reservoir	Bolt	M6	2	7	0.7	5.1	
Radiator bracket and frame	Bolt	M6	4	7	0.7	5.1	
Fuel pump	Bolt	M6	2	7	0.7	5.1	
Fuel tank	Bolt	M8	2	30	3.0	22	
Muffler stay	Bolt	M6	2	11	1.1	8.0	
Muffler and exhaust pipe	Bolt	M8	1	20	2.0	14	
Muffler bracket and muffler	Bolt	M8	1	20	2.0	14	
Muffler bracket and frame	Bolt	M8	2	20	2.0	14	
Muffler damper and muffler	Bolt	M6	1	10	1.0	7.2	
Muffler damper and frame	Bolt	M6	1	10	1.0	7.2	
Exhaust pipe	Nut	M8	4	14	1.4	10	
Air duct assembly 1	Bolt	M6	2	7	0.7	5.1	
Air duct assembly 2 and left protector	Bolt	M6	1	7	0.7	5.1	
Air duct assembly 2 and frame	Bolt	M6	1	7	0.7	5.1	
Gear position switch	Bolt	M5	2	7	0.7	5.1	
Thermo switch 1 (cylinder head)	—	1/8	1	8	0.8	5.8	
Thermo switch 3 (radiator)	—	M18	1	28	2.8	20	
Reverse switch	—	M10	1	20	2.0	14	
Engine ground lead	Bolt	M6	1	10	1.0	7.2	
Starter motor and engine	Bolt	M6	2	10	1.0	7.2	

SPECIFICATIONS

Chassis tightening torques

Part to be tightened	Thread size	Tightening torque			Remarks
		Nm	m · kg	ft · lb	
Rubber connecting bracket 1(or 2) and frame	M10	52	5.2	37	
Engine and Rubber connecting bracket 2 (front)	M10	52	5.2	37	
	M6	10	1.0	7.2	
Engine and Rubber connecting bracket 1 (rear)	M8	33	3.3	24	
	M6	10	1.0	7.2	
Rear upper arm and frame	M10	45	4.5	32	
Rear lower arm and frame	M10	45	4.5	32	
Rear knuckle and rear upper arm	M10	45	4.5	32	
Rear knuckle and rear lower arm	M10	45	4.5	32	
Rear shock absorber and frame	M10	45	4.5	32	
Rear shock absorber and rear lower arm	M10	45	4.5	32	
Rear Balancing pole and frame	M8	32	3.2	23	
ball head of Rear Balancing pole and Rear Balancing pole	M10	56	5.6	40	
ball head of Rear Balancing pole and rear lower arm	M10	56	5.6	40	
Differential gear case and frame	M10	55	5.5	40	
Differential gear case filler plug	M14	23	2.3	17	
Differential gear case drain plug	M10	10	1.0	7.2	
Universal joint yoke and drive pinion gear	M14	62	6.2	45	
Differential motor and differential gear case cover	M8	13	1.3	9.4	
Differential gear case cover and differential gear case	M8	25	2.5	18	
Rear driving axle gear case and frame	M10	70	7.0	51	
Rear driving axle gear case filler plug	M20	23	2.3	17	
Rear driving axle gear case drain plug	M10	20	2.0	14	
Ring gear bearing housing and final drive gear case	M8	23	2.3	17	
	M10	40	4.0	29	
Ring gear stopper nut	M8	16	1.6	11	
Bearing retainer and final gear pinion gear bearing housing	M65	170	17.0	125	Left-hand threads
Coupling gear and final drive pinion gear	M12	80	8.0	58	
Front upper arm and frame	M10	45	4.5	32	
Front lower arm and frame	M10	45	4.5	32	
Front shock absorber and frame	M10	45	4.5	32	
Front shock absorber and front upper arm	M10	45	4.5	32	
Steering shaft assembly and steering Cross gimbal	M8	22	2.2	16	
Steering assembly and steering Cross gimbal	M8	22	2.2	16	
Steering assembly and frame	M10	48	4.8	35	
Steering shaft assembly and frame	M8	21	2.1	15	
Steering wheel and steering shaft assembly	M12	35	3.5	25	
Steering knuckle and front upper arm	M12	30	3.0	22	
Steering knuckle and front lower arm	M12	30	3.0	22	
Tie-rod locknut	M12	40	4.0	29	
Steering knuckle and tie-rod	M12	39	3.9	28	
Front lower arm protector board and front lower arm	M6	7	0.7	5.1	
Seat belt and frame	M10	59	5.9	43	

SPECIFICATIONS

Part to be tightened	Thread size	Tightening torque			Remarks	
		Nm	m · kg	ft · lb		
Seat belt and ceiling (enclosure)	7/16	59	5.9	43	Stake	
Front wheel and front wheel hub	M10	55	5.5	40		
Front wheel hub and constant velocity joint of half shaft	M20	260	26.0	190		
Steering knuckle and brake disc guard	M6	7	0.7	5.1		
Front brake caliper and front wheel steering knuckle	M10	48	4.8	35		
Front brake hose union bolt	M10	27	2.7	19		
Front brake hose holder and steering knuckle	M6	7	0.7	5.1		
Front brake hose holder and front upper arm	M6	7	0.7	5.1		
Front brake hose holder and frame	M6	7	0.7	5.1		
Front brake pad holding bolt	M8	18	1.8	13		
Front brake disc and front wheel hub	M8	30	3.0	22		
Front brake caliper bleed screw	M6	6	0.6	4.3		
Rear wheel and rear wheel hub	M10	55	5.5	40		Stake
Rear wheel hub and constant velocity joint of half shaft	M20	260	26.0	190		
Rear brake hose and frame	M6	7	0.7	5.1		
Brake pipe and brake master cylinder	M10	19	1.9	13		
Pedal holder assembly and frame	M8	16	1.6	11		
Brake master cylinder and pedal holder assembly	M8	16	1.6	11		
Secondary brake master cylinder kit stopper bolt	M6	9	0.9	6.5		
Brake rod locknut	M8	17	1.7	12		
Rear brake disc and brake disc Install seat	M6	10	1.0	7.2		
Rear brake pad holding bolt	M8	17	1.7	12		
Rear brake caliper and Install seat	M10	40	4.0	29		
Rear brake hose union bolt	M10	27	2.7	19		
Parking brake case and rear brake caliper	M8	22	2.2	16		
Parking brake lever assembly and frame	M6	7	0.7	5.1		
Rear brake caliper bleed screw	M6	5	0.5	3.6		
Front bumper protector board and front bumper	M6	7	0.7	5.1		
Front bumper and frame	M10	32	3.2	23		
	M12	59	5.9	43		
Upper instrument panel and frame	M6	7	0.7	5.1		
ceiling side frame (enclosure) and frame	M10	64	6.4	46		
Support frame (enclosure) and frame	M10	64	6.4	46		
Support frame (enclosure) and side frame (enclosure)	M10	64	6.4	46		
Top frame (enclosure) and side frame (enclosure)	M10	64	6.4	46		
Seat support and frame	M8	16	1.6	11		
Footrest plate and frame	M6	7	0.7	5.1		

SPECIFICATIONS

GENERAL TIGHTENING TORQUE SPECIFICATIONS

This chart specifies tightening torques for standard fasteners with a standard ISO thread pitch. Tightening torque specifications for special components or assemblies are provided for each chapter of this manual. To avoid warpage, tighten multi-fastener assemblies in a crisscross pattern and progressive stages until the specified tightening torque is reached. Unless otherwise specified, tightening torque specifications require clean, dry threads. Components should be at room temperature.

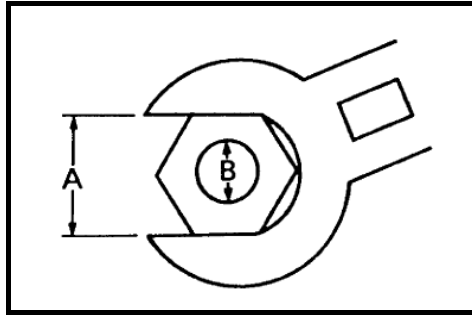

A: Distance between flats

B: Outside thread diameter

A (nut)	B (bolt)	General tightening torques		
		Nm	m · kg	ft · lb
10 mm	6 mm	6	0.6	4.3
12 mm	8 mm	15	1.5	11
14 mm	10 mm	30	3.0	22
17 mm	12 mm	55	5.5	40
19 mm	14 mm	85	8.5	61
22 mm	16 mm	130	13.0	94

SPECIFICATIONS

LUBRICATION POINTS AND LUBRICANT TYPES

Engine

Lubrication points	Lubricant
Oil seal lips	Apply lithium-soap-based grease
Bearings	Apply engine oil
O-rings	Apply lithium-soap-based grease
Piston, piston ring	Apply engine oil
Piston pin	Apply engine oil
Buffer boss and balancer drive gear	Apply engine oil
Crankshaft seal and spacer	Apply engine oil
Valve stem	Apply molybdenum disulfide oil
Valve stem end	Apply molybdenum disulfide oil
Rocker arm shaft	Apply engine oil
Rocker arm	Apply molybdenum disulfide grease
Camshaft lobe and journal	Apply molybdenum disulfide grease
Oil pump assembly	Apply engine oil
Oil filter cartridge O-ring	Apply lithium-soap-based grease
Starter idle gear shaft	Apply molybdenum disulfide grease
Starter wheel gear	Apply engine oil
Clutch housing assembly shaft end	Apply lithium-soap-based grease
Clutch carrier assembly	Apply engine oil
One-way clutch bearing	Apply molybdenum disulfide grease
Middle driven shaft splines	Apply molybdenum disulfide oil
Drive axle, driven sprocket, high wheel gear, and low wheel gear	Apply molybdenum disulfide oil
Middle drive gear and clutch dog shift fork groove	Apply molybdenum disulfide oil
Driven chain/sprocket	Apply engine oil
Shift drum	Apply engine oil
Shift fork guide bar	Apply engine oil
Shift drum stopper ball	Apply engine oil
Shift lever 2 assembly	Apply lithium-soap-based grease
Shift lever 1	Apply engine oil
Shift lever 1 and shift lever 2 assembly mating surface	Apply engine oil

SPECIFICATIONS

CHASSIS

Lubrication points	Lubricant
Lip of oil seal (full)	Light lithium-base grease
o-ring(full)	Light lithium-base grease
Steering shaft (upper end ,lower end)	Light lithium-base grease
Ball connection of steering pushing rod	Light lithium-base grease
Front wheel fork(ball-shaped joint)	Light lithium-base grease
Front wheel fork (ball-shaped joint)	Light lithium-base grease
Front wheel bearing	Light lithium-base grease
Front & rear brake	Light lithium-base grease
Dust-proof ring of brake	Light lithium-base grease
Joint of front brake cable	Light lithium-base grease
Front brake lever axle and rear brake lever axle	Light lithium-base grease
Adjusting nut and pin of rear brake cable	Light lithium-base grease
Rear brake pedal pivot and brake pedal axle hole	Light lithium-base grease
Throttle rotating frame shaft and end section of throttle cable	Light lithium-base grease
Reverse gear lever pivot	Light lithium-base grease
Connection bolt of rear wheel fork and frame,rear wheel fork bearing	Light lithium-base grease
Rubber sleeve and rear wheel fork	Seal gum
Rear shock absorber bushing	Light lithium-base grease

SPECIFICATIONS

HYDROGRAPHIC CHART

Hydrographic chart

⇨ : Pressure

→ : splash

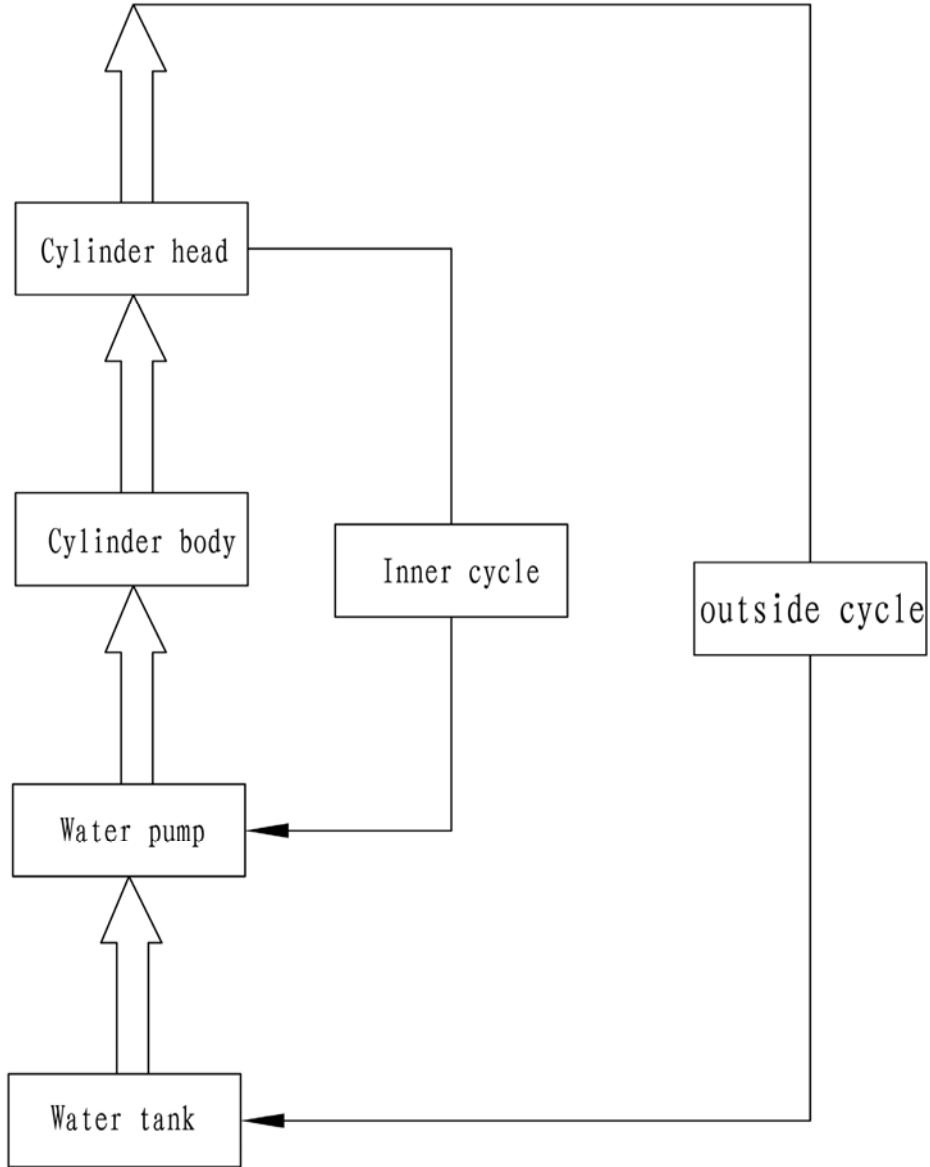

SPECIFICATIONS

LUBRICATION OIL WAY

Hydrographic chart

→ : Pressure

→ : splashing oil

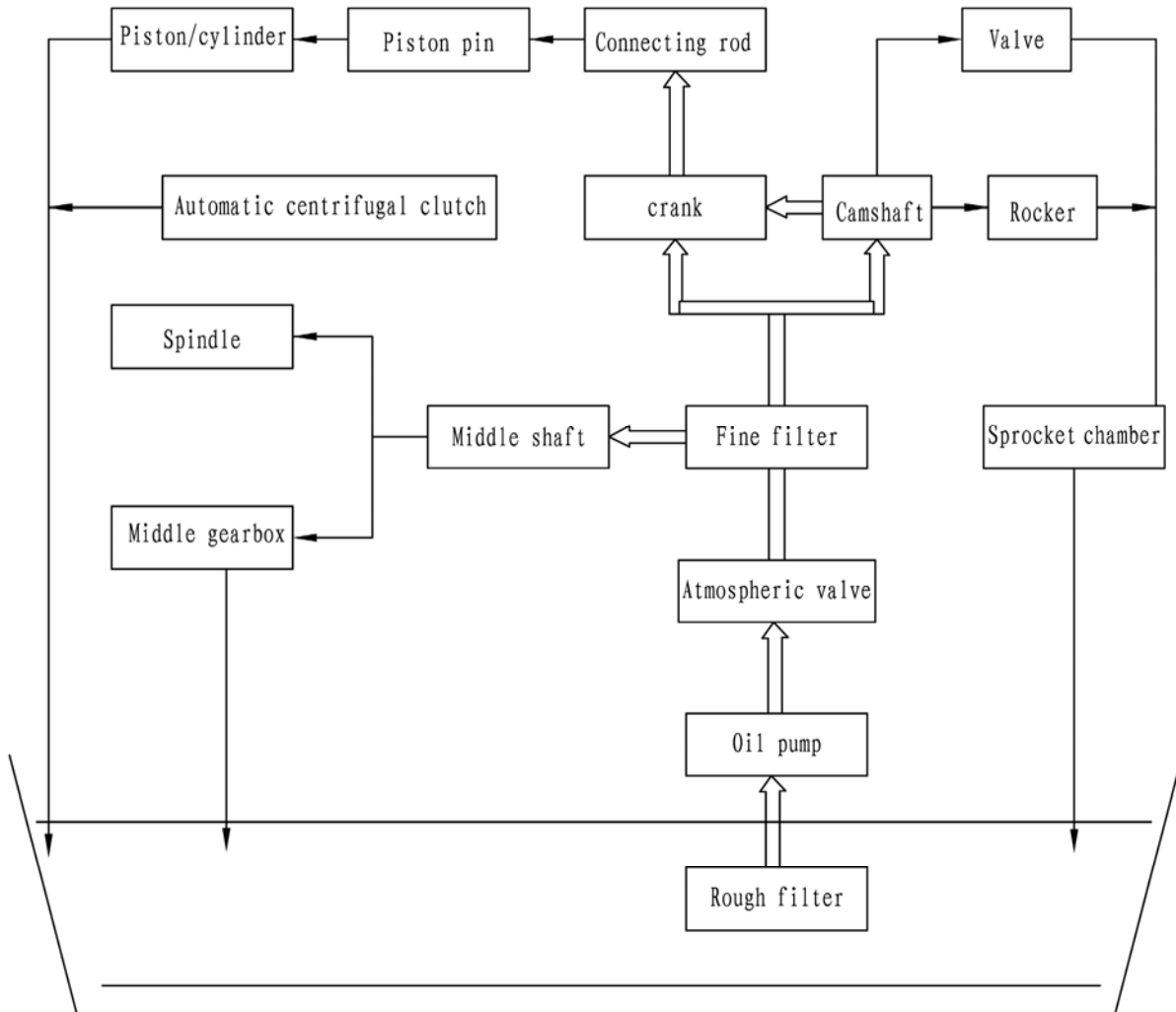

MAINTENANCE AND ADJUSTMENT OF THE ATV

MAINTENANCE AND ADJUSTMENT OF THE ATV

NOTE:

The correct maintenance and adjustment are necessary to ensure vehicle and normal driving
The repair personnel should be familiar with the contents of this article.

MAINTENANCE SCHEDULE

ITEM	ROUTINE	Whichever comes first →	EVERY			INITIAL		
			month	1	3	6	6	12
			km	320	1,200	2,400	2,400	4,800
			(mi)	(200)	(750)	(1,500)	(1,500)	(3,000)
hours	20	75	150	150	300			
Exhaust system*	<ul style="list-style-type: none"> · Check for leakage. · Tighten if necessary. · Replace gasket(s) if necessary. 				○		○	
Spark arrester	<ul style="list-style-type: none"> · Clean. 				○	○	○	
Fuel line*	<ul style="list-style-type: none"> · Check fuel hose for cracks or damage. · Replace if necessary. 				○	○	○	
Air filter element	<ul style="list-style-type: none"> · clean. · Replace if necessary. 	Every 20-40 hours (More often in wet or dusty areas.)						
Front brake*	<ul style="list-style-type: none"> · Check operation/ fluid leakage. · Correct if necessary. 	○	○	○	○	○	○	
Rear brake*	<ul style="list-style-type: none"> · Check operation. · Adjust if necessary. 	○	○	○	○	○	○	
Wheel	<ul style="list-style-type: none"> · Check balance/damage/ · Repair if necessary. 	○		○	○	○	○	
Front and rear suspension*	<ul style="list-style-type: none"> · Check operation. · Correct if necessary. 				○		○	
Wheel bearing*	<ul style="list-style-type: none"> · Check bearing assemblies for looseness /damage. · Replace if necessary. 	○			○	○	○	
Steering system*	<ul style="list-style-type: none"> · Check operation./Replace if damaged · check toe-in./Adjust if necessary. 	○	○	○	○	○	○	
Select lever safety system cable	<ul style="list-style-type: none"> · Check operation. · Adjust if necessary. 				○	○	○	
Drive shaft universal joint*	<ul style="list-style-type: none"> · Lubricate with lithium–soap–based grease. 				○	○	○	
Axle boots*	<ul style="list-style-type: none"> · Check operation. · Replace if damaged. 	○	○	○	○	○	○	
Fittings and fasteners*	<ul style="list-style-type: none"> · Check all chassis fittings and fasteners. · Correct if necessary. 	○	○	○	○	○	○	

MAINTENANCE AND ADJUSTMENT OF THE ATV

ITEM	ROUTINE	Whichever comes first →	EVERY			INITIAL		
			month	1	3	6	6	12
			km	320	1,200	2,400	2,400	4,800
			(mi)	(200)	(750)	(1,500)	(1,500)	(3,000)
			hours	20	75	150	150	300
Valves	<ul style="list-style-type: none"> • Check valve clearance. • Adjust if necessary. 		○		○	○	○	
Spark plug	<ul style="list-style-type: none"> • Check condition. • Adjust gap and clean. • Replace if necessary. 		○	○	○	○	○	
V-belt*	<ul style="list-style-type: none"> • Check operation. • Check for cracks or damage. 		○		○	○	○	
Crankcase breather system*	<ul style="list-style-type: none"> • Check breather hose for cracks or damage. • Replace if necessary. 				○	○	○	
Engine oil	<ul style="list-style-type: none"> • Replace. (Warm engine before draining.) 		○		○	○	○	
Engine oil strainer*	<ul style="list-style-type: none"> • Clean. 		○	○	○		○	
Engine oil filter cartridge	<ul style="list-style-type: none"> • Replace. 		○	○	○		○	
Final gear oil	<ul style="list-style-type: none"> • Check oil level /oil leakage. 		○				○	
Differential gear oil	<ul style="list-style-type: none"> • Replace 						○	
Lights and switches*	<ul style="list-style-type: none"> • Check operation. • Adjust headlight beams. 		○	○	○	○	○	

NOTE:

- **Recommended brake fluid: DOT 4**
- **Brake fluid replacement:**
- **When disassembling the master cylinder or caliper, replace the brake fluid. Normally check the brake fluid level and add fluid as required.**
- **On the inner parts of the master cylinder and caliper, replace the oil seals every two years.**
- **Replace the brake hoses every four years, or if cracked or damaged.**

MAINTENANCE AND ADJUSTMENT OF THE ATV

ENGINE

ADJUSTING THE VALVE CLEARANCE

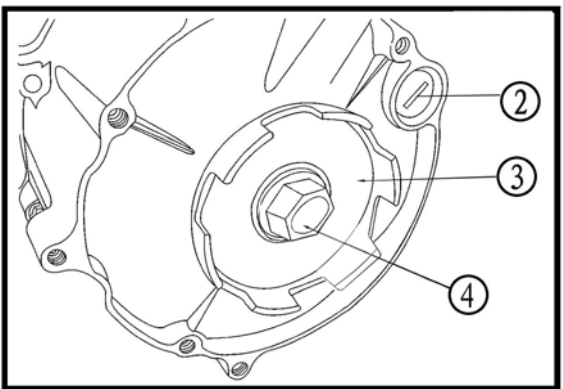
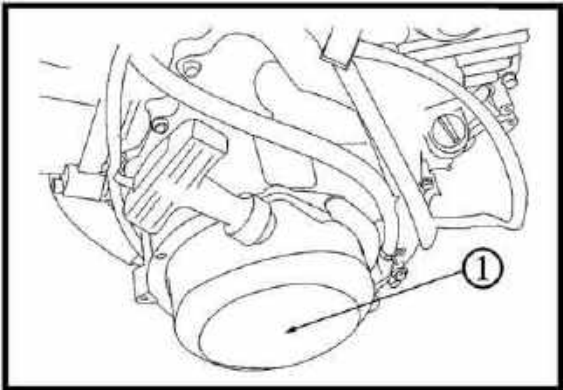
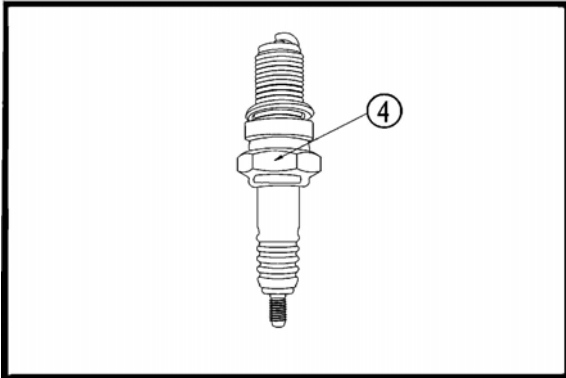
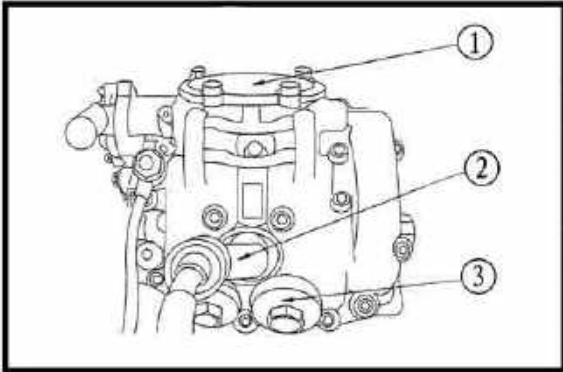

NOTE:

- The valve clearance must be adjusted when the engine is cool to the touch.
- Adjust the valve clearance when the piston is at the Top Dead Center TDC on the compression stroke.
- Remove:
 - driver seat
 - passenger seat
 - console

1. Remove following parts:

- ① Valve cover(exhaust)
- ② spark plug cap
- ③ Valve cover(intake)
- ④ spark plug

2. Remove the manual starting mechanism:

- ① manual starting mechanism cover
- ② As manhole covers
- ③ Pulley starter
- ④ M10×40 bolt

MAINTENANCE AND ADJUSTMENT OF THE ATV

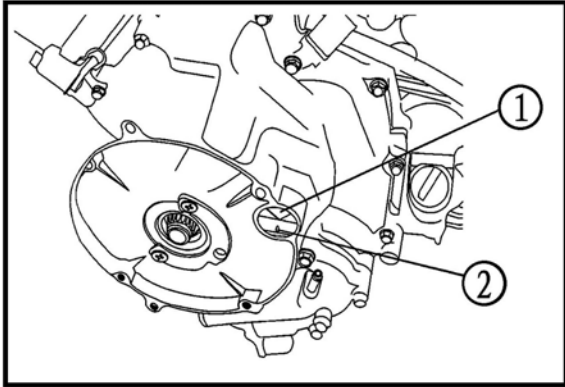

3. calibration

- Wrench to counterclockwise rotation crankshaft
According to the rotor turning counterclockwise, rotor turn to mark the dead spots ② of crank box, namely ① the dead point position is compressed.

4. Check:

- valve clearance
- Beyond the standard → Adjust.

Valve clearance (cold)

Intake

0.08 ~ 0.12 mm

(0.0032 ~ 0.0047 in)

Exhaust

0.12 ~ 0.15 mm

(0.0047 ~ 0.0059 in)

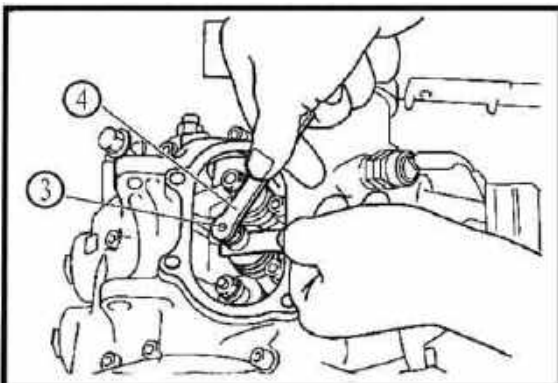
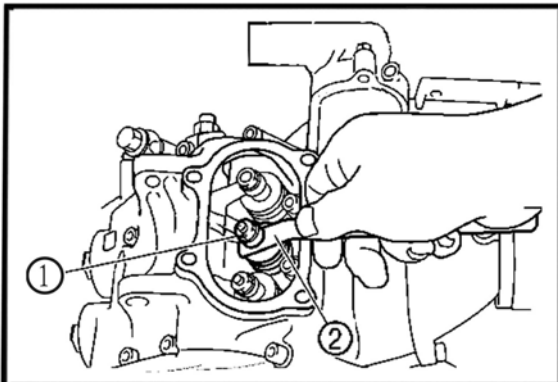

5. Adjust:

valve clearance

- ①、 Lock nut
- ②、 Valve thickness gauge (gap Regulation)
- ③、 Regulator
- ④、 Adjust tools

- Loosen the locknut ①.
- Insert a thickness gauge ③ between the adjuster end and the valve end.
- Turn the adjuster ③ clockwise or counterclockwise with the tappet adjusting tool ④ until the proper clearance is obtained.
- In order to avoid the regulator, adjust rotation together after fastening tool fixed lock nut.

14Nm (1.4 m · kg, 10 ft · lb)

- Measuring clearance rules with the valve clearance.
- If the gap beyond the standard value, repeat the above steps until the correct gap.

6. Install all removed parts

MAINTENANCE AND ADJUSTMENT OF THE ATV

According to remove the reverse order for installation

- Engine starter components
- manual starting mechanism cover
- spark plug
- Valve cover (exhaust)
- Valve cover (intake)
- console
- driver seat

Refer to "SEATS," in chapter 5.

CHECKING THE SPARK PLUG

1. Remove:

pull out the spark plug cap ① and remove the spark plug by sleeve

2. Check:

- spark plug type

Incorrect → Replace.

**Standard spark plug
DCPR7E /NGK**

3. Check:

- electrode ①

To check if it is burned blunt or much carbon is there, then check the pole clearance by thickness gauge. It is qualified if the pole clearance is between 0.6 to 0.7mm. Otherwise it should be adjusted.

Wear/damage → Replace.

- insulator ②

Abnormal color → Replace.

Normal color is a medium-to-light tan color.

4. Clean the spark plug with a spark plug cleaner or wire brush.

5. Install:

- spark plug

18 Nm -20 Nm (1.8 m · kg, 13 ft · lb)

- Then hook up the spark plug cap.

NOTE:

Before installing a spark plug, clean the gasket surface and plug surface

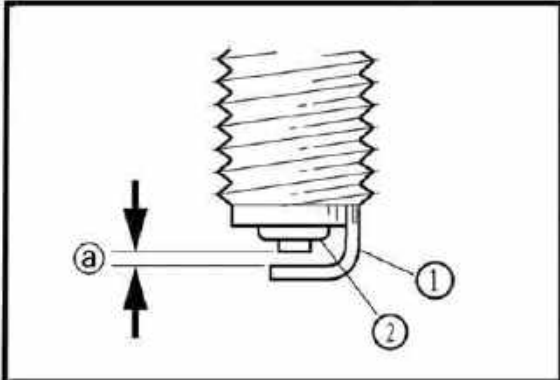
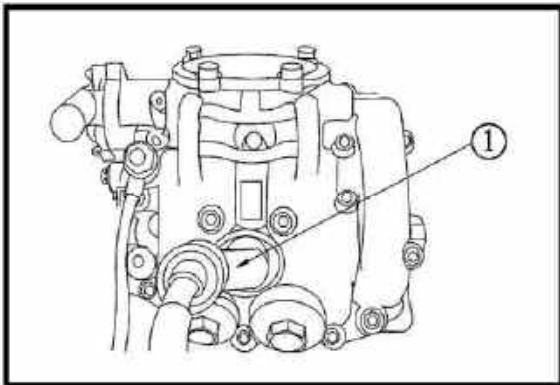

MAINTENANCE AND ADJUSTMENT OF THE ATV

CHECKING THE IGNITION TIMING

NOTE:

Before checking the ignition timing, adjust the engine's racing speed and throttle cable.

1. Remove:

- driver seat
- console

Refer to "SEATS" in chapter 5.

2. Attach:

- tachometer
- timing light
(to the spark plug lead)

3. Remove:

Refer to the sequence of hand pulling starter ① dismounting in the process of valve clearance adjusting.

4. Check:

- ignition timing

a. Warm up the engine and keep it at the specified speed

Engine speed
1,400 ~ 1,500 r/min

b. Remove As manhole covers ②

c. Visually check the stationary pointer ③ to verify it is within the required firing range④indicated on the flywheel.

Incorrect firing range → Check the pulser coil assembly.

d. Install the timing plug.

5. Install:

- Engine manual starting mechanism

7 Nm (0.7 m · kg, 5.1 ft · lb)

6. Install:

- manual starting mechanism cover

10 Nm (1.0 m · kg, 7.2 ft · lb)

7. Detach:

- timing light

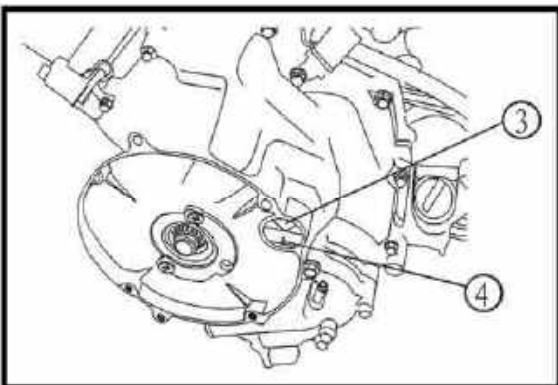
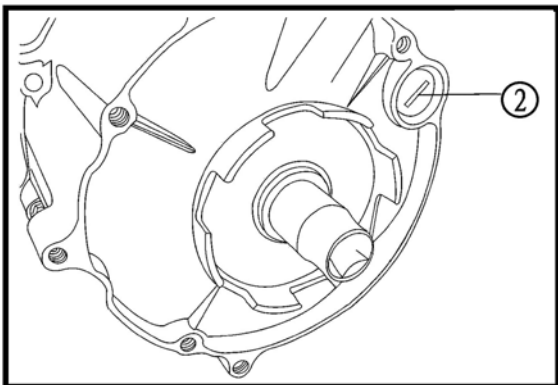
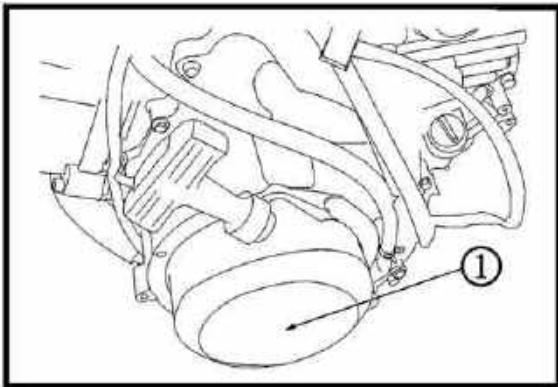

MAINTENANCE AND ADJUSTMENT OF THE ATV

- tachometer

8. Install:

- console
- driver seat

Refer to "SEATS" in chapter 5.

MEASURING THE COMPRESSION PRESSURE

NOTE:

Insufficient compression pressure will result in a loss of performance.

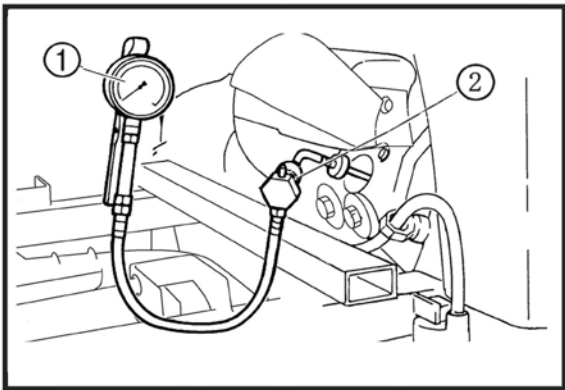

1. Start the engine and let it warm up for several minutes.
2. Stop the engine and remove the spark plug.
3. Assemble the compression pressure meter ① and joint utensil ② on the hole of the spark plug
4. check standard value

**standard compression pressure data
1200Kpa (12kg/c)-1000r/min**

5. read the highest data on the compression pressure meter
- Above the maximum pressure:
Check the cylinder head, valve surfaces, and piston crown for carbon deposits.
 - Below the minimum pressure:
Check the accumulation carbon in the firebox of the cylinder head and accumulation carbon on the piston head.
 - Refer to the table below.

Compression pressure(with oil introduced into cylinder)	
Reading	Diagnosis
Higher than without oil	Worn or damaged pistons
Same as without oil	Defective ring(s), valves, cylinder head gasket or piston is possible.

MAINTENANCE AND ADJUSTMENT OF THE ATV

Compression pressure

(at sea level)

Standard: 1,324Kpa

(13.24 kg/cm², 188.31Psi)

Minimum: 1,150Kpa

(11.5 kg/cm², 163.57Psi)

Maximum: 1,480Kpa

(14.8 kg/cm², 210.50Psi)

- Crank over the engine with the electric starter (be sure the battery is fully charged) with the throttle wide-open until the compression reading on the gauge stabilizes.

NOTE:

When cranking the engine, ground the spark plug lead to prevent sparking.

6. Install:

- spark plug

18 Nm-20Nm (1.8 m · kg, 13 ft · lb)

CHECKING THE ENGINE OIL LEVEL

1. Place the vehicle on a level surface

2. Remove:

- driver seat
- console

Refer to "SEATS" in chapter 5.

3. Check:

- engine oil level

Oil level should be between the maximum

① and minimum ② marks.

Oil level low → Add oil to the proper level.

NOTE:

Do not screw the dipstick 3 in when checking the oil level.

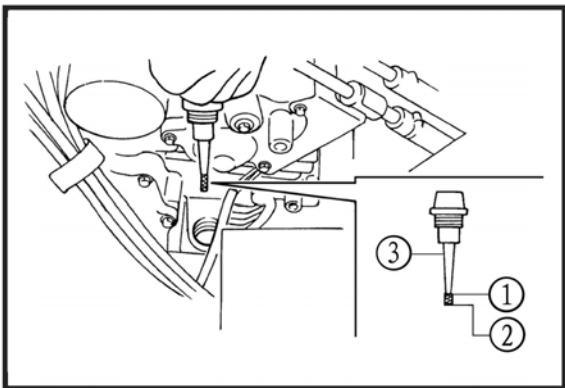

Recommended oil
Follow the left chart.

MAINTENANCE AND ADJUSTMENT OF THE ATV

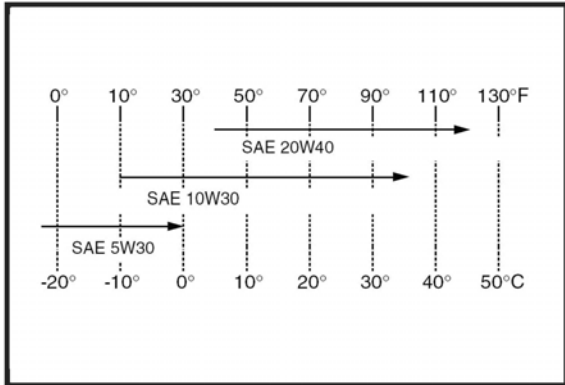

NOTE:

Recommended oil classification:
API Service “SE”, “SF”, “SG” type or equivalent (e.g. “SF—SE—CC”, “SF—SE—SD” etc.)

NOTE:

Do not allow foreign material to enter the crankcase.

4. Start the engine and let it warm up for several
5. Stop the engine and check the oil level again.

NOTE:

Wait a few minutes until the oil settles before checking the oil level.

NOTE:

Never remove the dipstick just after high speed operation because the heated oil could spurt out. Wait until the oil cools down before removing the dipstick.

6. Install:

- console
- driver seat

Refer to “SEATS” in chapter 5.

CHANGING THE ENGINE OIL

Place the vehicle on a level surface.

1. Start the engine and let it warm up for several minutes.
2. Stop the engine and place an oil pan under the engine.
3. Remove:
 - driver seat
 - cover piece
4. Remove:
 - engine oil filler plug (dipstick) ①
 - engine oil drain bolt ② drain the engine oil from

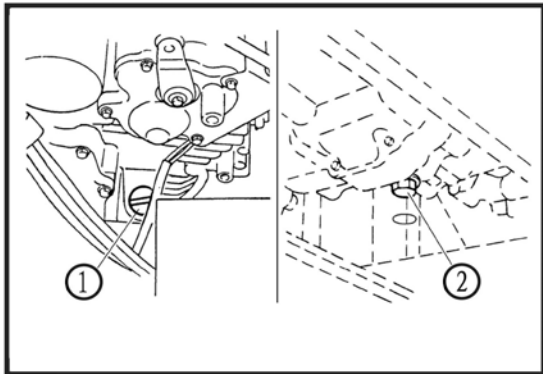

MAINTENANCE AND ADJUSTMENT OF THE ATV

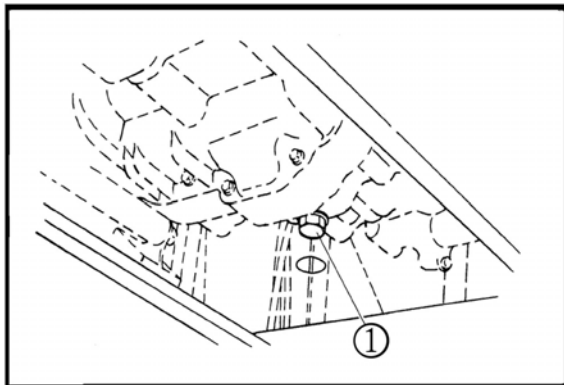
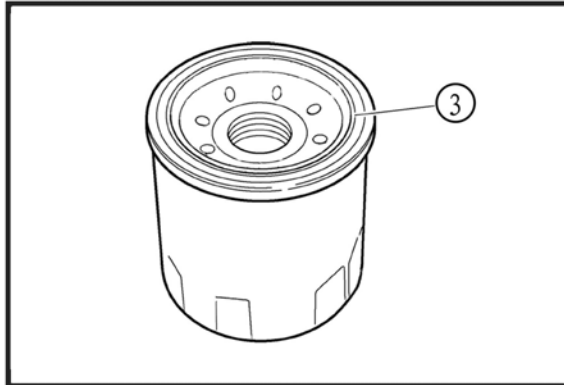
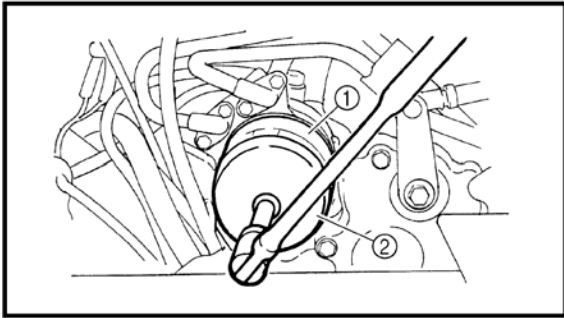

the crankcase.

5. If the oil filter cartridge is also to be replaced, perform the following procedure.

- Remove the oil filter cartridge ① with an Oil filter detacher ②.
- Lubricate the O-ring ③ of the new oil filter cartridge with a thin coat of lithium-soap-based grease.

NOTE:

Make sure that the O-ring ③ is positioned correctly in the groove of the oil filter cartridge.

- Tighten the new oil filter cartridge to specification with an oil filter wrench.

Oil filter cartridge

17 Nm (1.7 m · kg, 12 ft · lb)

6. Install:

- engine oil drain bolt ①

7. Fill:

- Before the oil is put into the crankcase, please cleanout oil filter and make it in good working condition, then assemble.
- crankcase (with sufficient oil to reach the specified level)

Oil quantity

Periodic oil change

The oil capacity after the engine is disassembled and reassembled.

1.9L

The oil should be put into the engine for after all the oil is drawn out

1.8L

8. Install:

- engine oil filler plug

9. Warm up the engine for a few minutes, then stop the engine.

10. Check:

- engine (for engine oil leaks)

MAINTENANCE AND ADJUSTMENT OF THE ATV

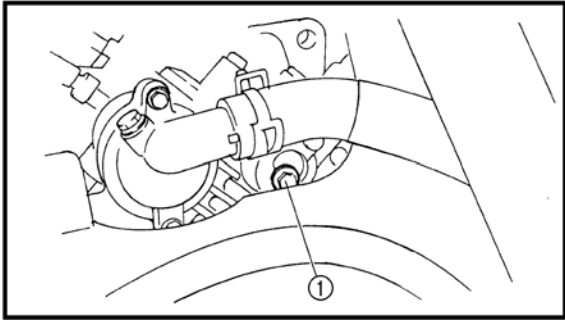

- oil level Refer to “THE ENGINE “ in chapter 4 .

11. Check:

- engine oil pressure
 - a. Slightly loosen the oil gallery bolt ①.
 - b. Start the engine and keep it idling until engine oil starts to seep from the oil gallery bolt. If no engine oil comes out after one minute, turn the engine off so that it will not seize.
 - c. Check the engine oil passages, the oil filter cartridge and the oil pump for damage or leakage. Refer to “THE ENGINE” in chapter 4.
 - d. Start the engine after solving the problem(s) and check the engine oil pressure again.
 - e. Tighten the oil gallery bolt to specification.

Oil gallery bolt

17 Nm (1.7 m · kg, 12 ft · lb)

12. Install:

- console
- driver seat

Refer to “SEATS” in chapter 5.

MAINTENANCE AND ADJUSTMENT OF THE ATV

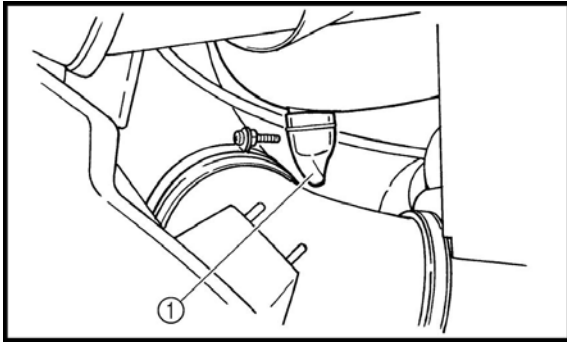

CHASSIS

CLEANING THE AIR FILTER

NOTE:

There is a check hose ① at the bottom of the air filter case. If dust and/or water collect in this hose, clean the air filter element and air filter case.

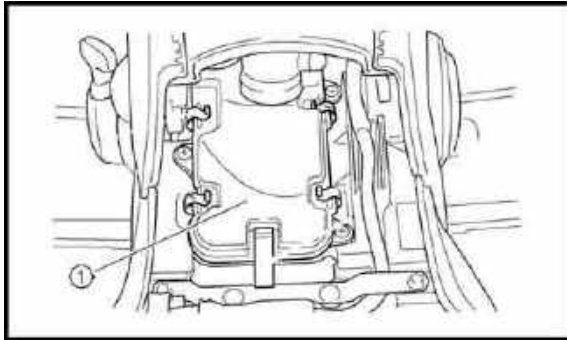

1. Remove:

- driver seat
- air filter case cover ①

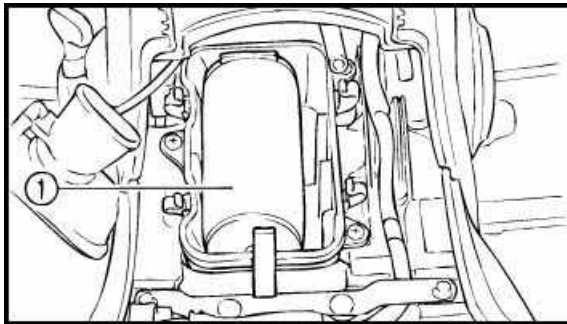

- air filter element assembly ①
- air filter element cap ②
- air filter element ③

NOTE:

Never operate the engine with the air filter element removed. This will allow unfiltered air to enter, causing rapid wear and possible engine damage. Additionally, operation without the filter element will affect carburetor tuning with subsequent poor performance and possible engine overheating.

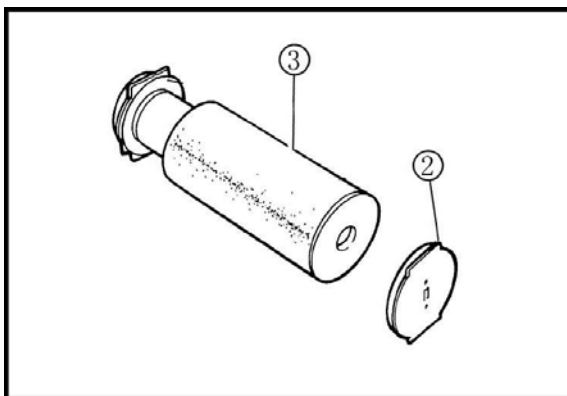

2. Check:

- air filter element
- Damaged → Replace.

3. Clean:

- air filter element

- a. Wash the element gently, but thoroughly in solvent

MAINTENANCE AND ADJUSTMENT OF THE ATV

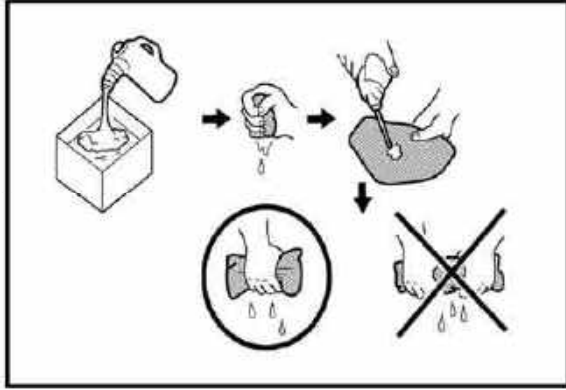

WARNING:

Use a cleaning solvent which is designed to clean parts only. Never use gasoline or low flash point solvents as they may cause a fire or explosion.

- b. Squeeze the excess solvent out of the element and let it dry.

NOTE:

Do not twist or wring out the element. This could damage the foam material.

- c. Squeeze out the excess oil.

NOTE:

The element should be wet but not dripping.

4. Install:

- air filter element
- air filter case cover

NOTE:

To prevent air leaks make sure that the sealing surface of the element matches the sealing surface of the case.

- driver seat

CHECKING THE COOLANT LEVEL

1. Place the vehicle on a level surface.
2. Lift the hood up.
3. Check:
 - start the engine, warm it up for several minutes, and then turn it off.
 - coolant level

NOTE:

Before checking the coolant level, wait a few minutes until the coolant has settled.

- coolant level

The coolant level should be between the minimum level mark ① and maximum level mark ②. Below the minimum level mark →

Add the recommended coolant to the proper level.

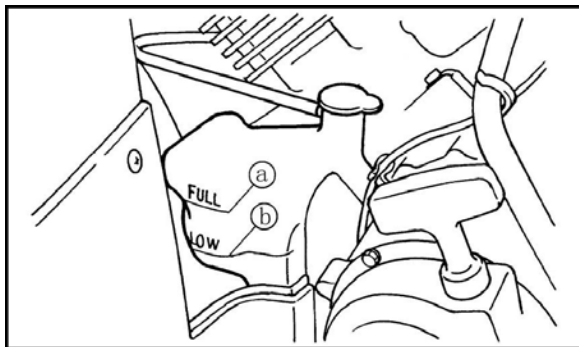

MAINTENANCE AND ADJUSTMENT OF THE ATV

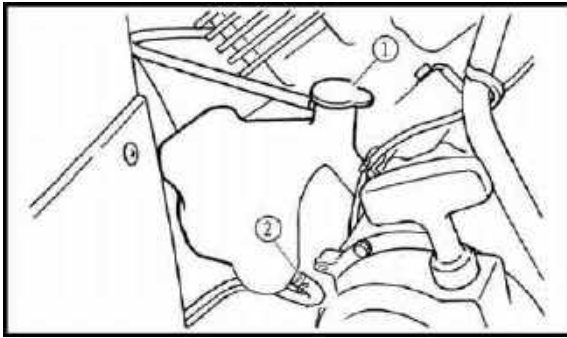

CHANGING THE COOLANT

1. Remove:

- driver seat;
- coolant reservoir cap ① ;
- Disconnect coolant reservoir hose ②;
- Adding water instead of coolant lowers the antifreeze content of the coolant. If water is used instead of coolant, check and if necessary, correct the antifreeze concentration of the coolant;
- Use only distilled water. However, soft water may be used if distilled water is not available.

2. Drain:

- coolant
(from the coolant reservoir)

3. Connect:

- coolant reservoir hose

4. Remove:

- coolant drain bolt (water pump) ① (along with the copper washer)

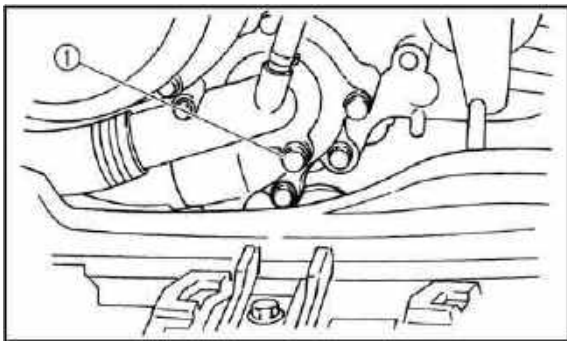

5. Remove:

- radiator cap ①

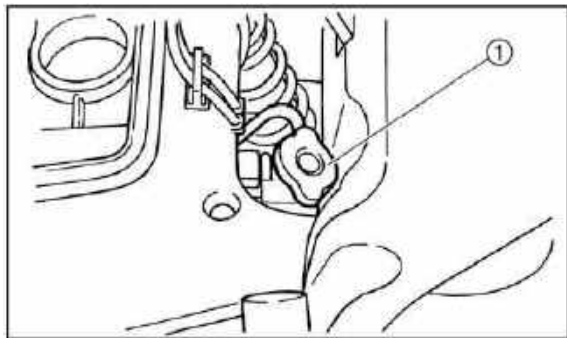

WARNING:

A hot radiator is under pressure. Therefore, do not remove the radiator cap when the engine is hot. Scalding hot fluid and steam may be blown out, which could cause serious injury. When the engine has cooled, open the radiator cap as follows: Place a thick rag or a towel over the radiator cap and slowly turn the radiator cap counterclockwise toward the detent to allow any residual pressure to escape.

When the hissing sound has stopped, turn the radiator cap counterclockwise while pressing down on it and then remove it.

MAINTENANCE AND ADJUSTMENT OF THE ATV

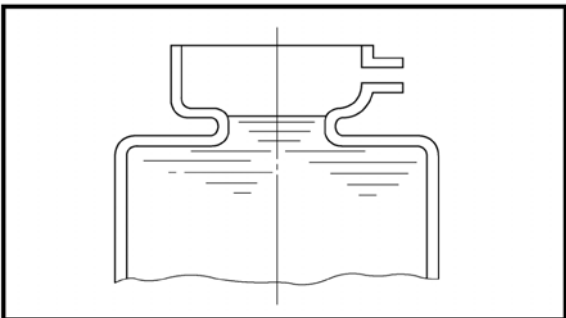
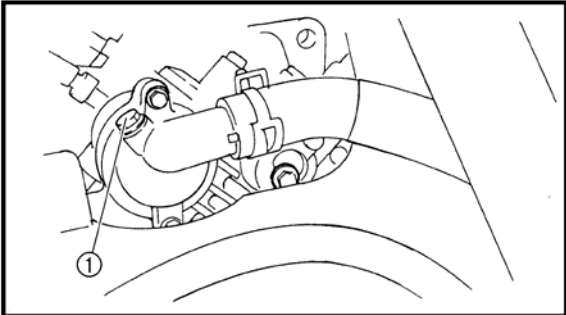
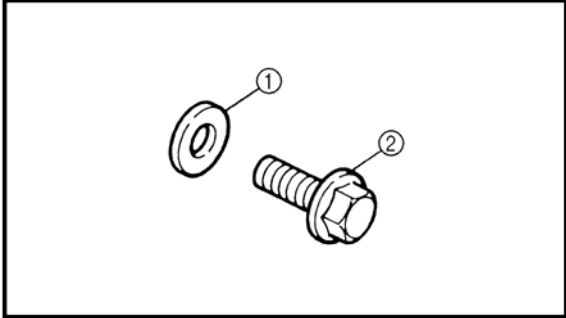
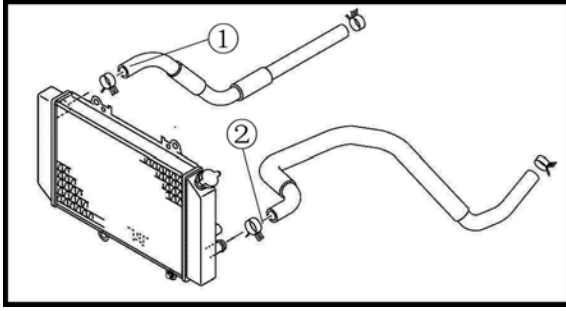

6. Drain:

- coolant

7. Disconnect:

- coolant outlet hose ①
- water pump inlet hose ②

8. Drain:

- coolant

9. Check:

- copper washer ①
 - coolant drain bolt ②
- Damage → Replace.

10. Install:

- coolant drain bolt (water pump) T R.

10 Nm (1.0 m · kg, 7.2 ft · lb)

11. Connect:

- water pump inlet hose
- coolant outlet hose

12. Remove:

- air bleed bolt ①

13. Fill cooling

(with the specified amount of the recommended coolant)

Recommended antifreeze

High-quality ethylene glycol antifreeze containing corrosion inhibitors for aluminum engines

Mixing ratio

1 : 1 (antifreeze : water)

Quantity total amount

2.5 L (2.20 Imp qt, 2.64 US qt)

Coolant reservoir capacity

0.35 L (0.31 Imp qt, 0.37 US qt)

NOTE:

The specified amount of coolant is a standard amount. Fill the cooling system with coolant until coolant comes out of the hole for the air bleed bolt.

Coolant is potentially harmful and should be handled with special care.

MAINTENANCE AND ADJUSTMENT OF THE ATV

WARNING:

- *If coolant splashes in your eyes, thoroughly wash them with water and consult a doctor;*
- *If coolant splashes on your clothes, quickly wash it away with water and then with soap and water;*
- *If coolant is swallowed, induce vomiting and get immediate medical attention;*
- *If coolant comes into contact with painted surfaces, immediately wash them with water;*
- *Do not mix different types of antifreeze.*

NOTE:

Adding water instead of coolant lowers the antifreeze content of the coolant. If water is used instead of coolant, check, and if necessary, correct the antifreeze concentration of the coolant. Use only distilled water. However, soft water may be used if distilled water is not available.

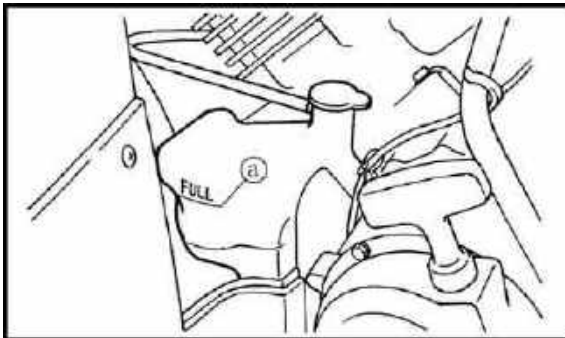

14. Install:

- air bleed bolt

9 Nm (0.9 m · kg, 6.5 ft · lb)

- radiator cap;
- Fill coolant reservoir;
(with the recommended coolant to the maximum level mark @)
- Install coolant reservoir cap:
 - Start the engine, warm it up for several minutes, and then turn it off.
- Check:
coolant level

Refer to "THE COOLANT" in chapter 4.

NOTE:

Before checking the coolant level, wait a few minutes until the coolant has settled.

- Close the hood.
- Install driver seat

Refer to "SEATS," in chapter 5.

MAINTENANCE AND ADJUSTMENT OF THE ATV

CHECKING THE COOLANT TEMPERATURE WARNING LIGHT

Coolant temperature indicator light ①

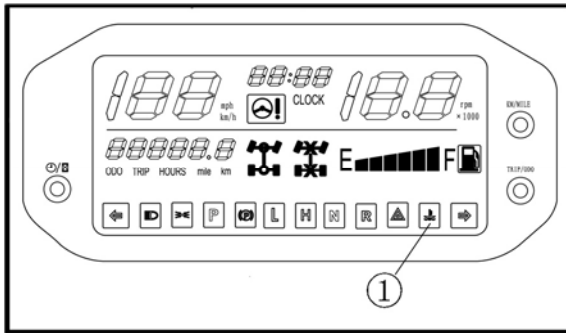

Coolant temperature warning light checking method

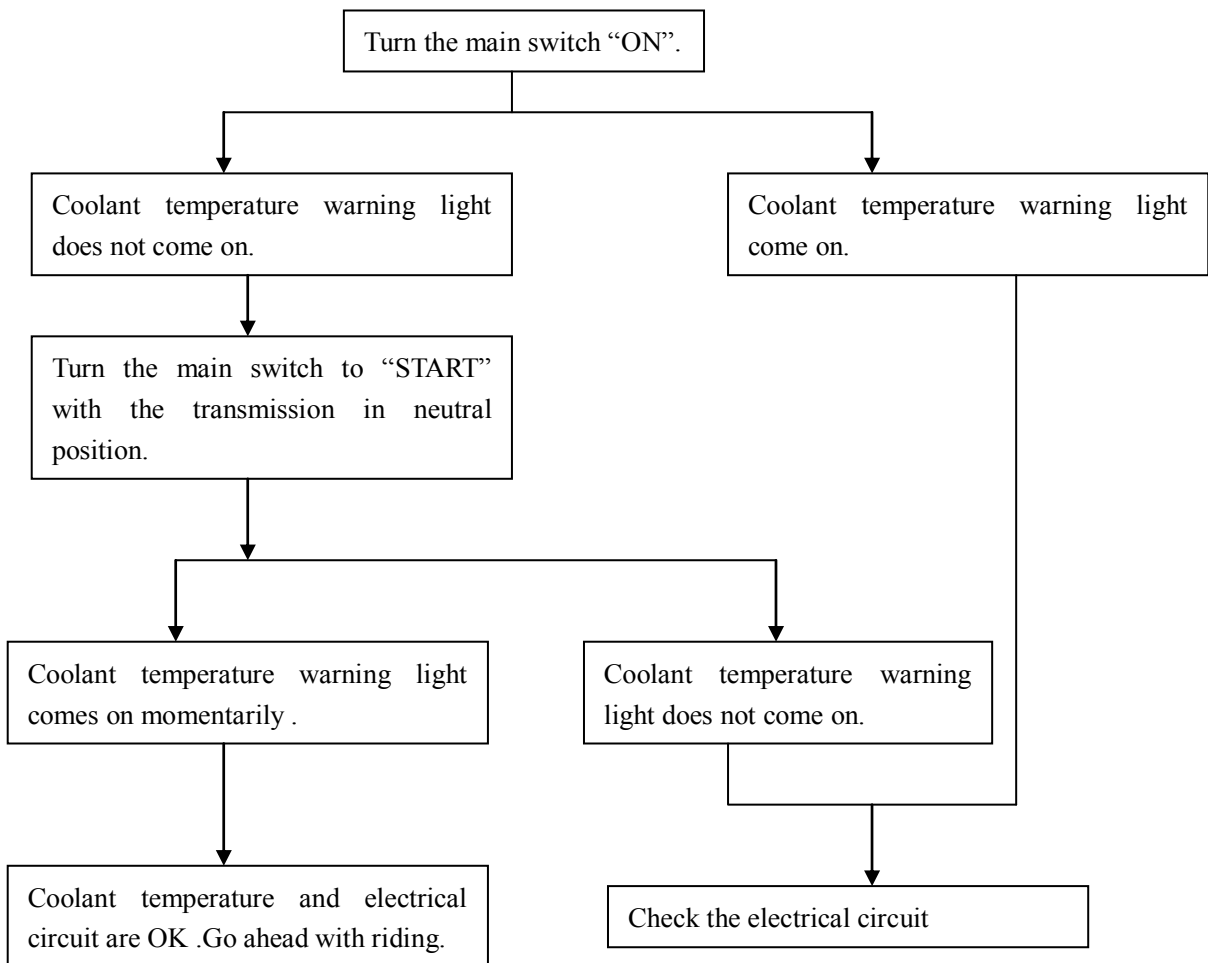

MAINTENANCE AND ADJUSTMENT OF THE ATV

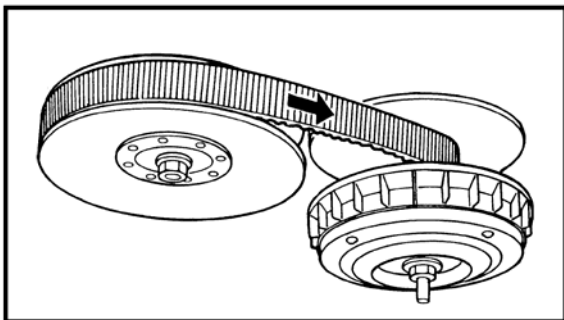
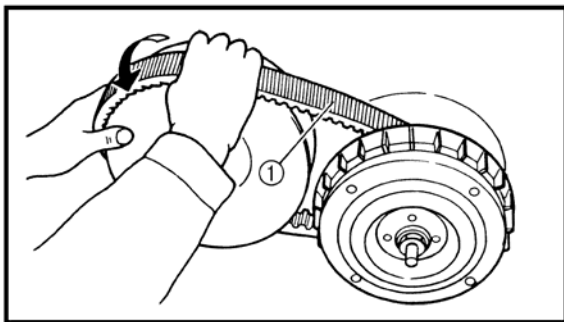
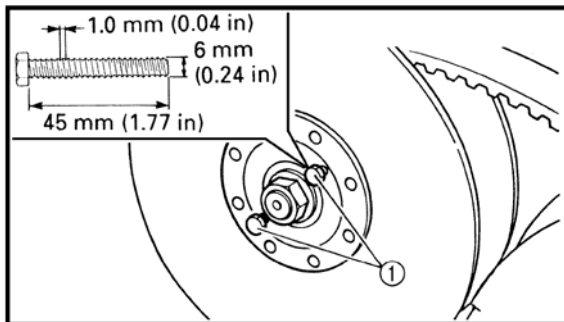
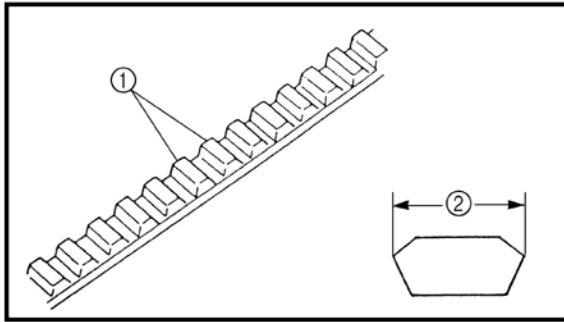

CHECKING THE V-BELT

1. Remove:

- driver seat
- drive belt cover
- Check:

a. V-belt ①

Cracks/wear/scaling/chipping → Replace.

Oil/ grease → Check primary sheave and secondary sheave.

b. V-belt width ②

Out of specification → Replace.

V-belt width

33.2 mm (1.31 in)

<Limit:> 29.9 mm (1.18 in)

- Replace V-belt:

Install the bolts ① into the secondary fixed sheave hold.

NOTE:

Tightening the bolts ① will push the secondary sliding sheave away, causing the gap between the secondary fixed and sliding sheaves to widen.

- Remove the V-belt ① from the primary sheave and secondary sheave.
- Install the V-belt.

NOTE:

Install the V-belt so that its arrow faces the direction shown in the illustration.

- Remove the bolts.
- #### 2. Install:
- drive belt cover
 - driver seat

CLEANING THE SPARK ARRESTER

1. Clean:

Tap the tailpipe lightly with a soft-face hammer or suitable tool, then use a wire brush to remove any carbon deposits from the spark arrester portion of

MAINTENANCE AND ADJUSTMENT OF THE ATV

the tailpipe and the inner contact surfaces of the muffler

2. spark arrester

WARNING:

- *Select a well-ventilated area free of combustible materials.*
- *Always let the exhaust system cool before performing this operation.*
- *Do not start the engine when removing the tailpipe from the muffler.*

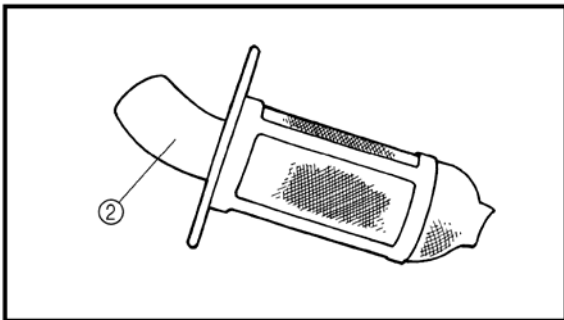
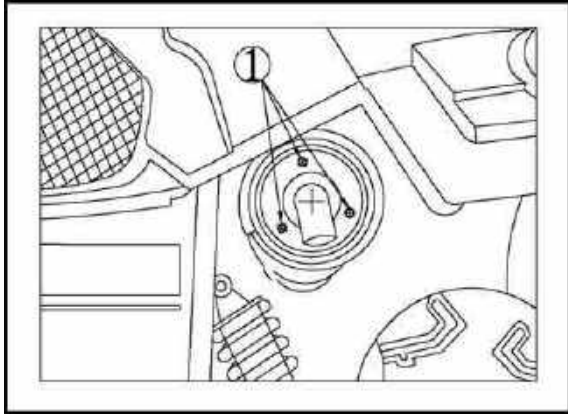

3. Remove:

- Remove the bolts ①.
- Remove the tailpipe ② by pulling it out of the muffler.

4. Install:

- Insert the tailpipe ② into the muffler and align the bolt holes.
- Insert the bolt 1 and tighten it.
- Start the engine and rev it up approximately twenty times while momentarily creating exhaust system back pressure by blocking the end of the muffler with a shop towel.
- Stop the engine and allow the exhaust pipe to cool.

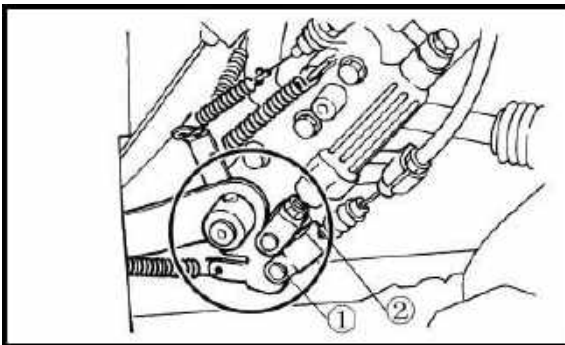

ADJUSTING THE BRAKE PEDAL

1. Check:

- brake pedal free play a Out of specification
→ adjust.

NOTE:

The end of the brake rod ① should lightly contact the brake master cylinder ②

**Brake pedal free play
0 mm (0.0 in)**

1. Adjust:

- brake pedal free play
a. Loosen the locknut ①

MAINTENANCE AND ADJUSTMENT OF THE ATV

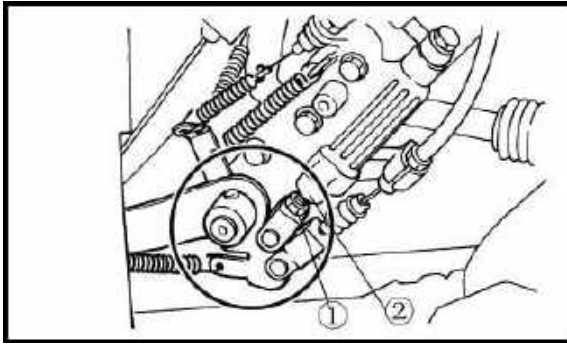

- b. Turn brake rod ② in or out until the correct free play is obtained.

Turning in	Free play is increased.
Turning out	Free play is decreased.

- c. Tighten the locknut to specification.

Locknut
17 Nm (1.7 m · kg, 12 ft · lb)

NOTE:

Make sure that there is no brake drag on the front or rear wheels.

CHECKING THE BRAKE FLUID LEVEL

1. Place the vehicle on a level surface.

NOTE:

When checking the brake fluid level, make sure that the top of the brake fluid reservoir top is horizontal.

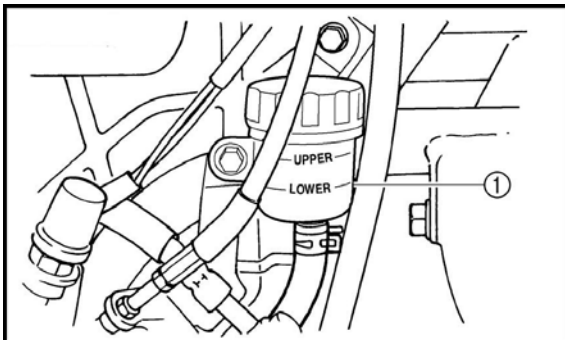

2. Lift the hood up.

3. Check:

- brake fluid level Fluid level is under "MIN" ① line → Fill up.

NOTE:

Brake fluid may erode painted surfaces or plastic parts. Always clean up spilled fluid immediately.

WARNING:

- *Use only the designed quality brake fluid: otherwise, the rubber seals may deteriorate, causing leakage and poor brake performance.*
- *Refill with the same type of brake fluid: mixing fluids may result in a harmful chemical reaction and lead to poor performance.*
- *Be careful that water does not enter the master cylinder when refilling. Water will significantly lower the boiling point of the fluid and may result in a vapor lock.*

4. Close the hood.

MAINTENANCE AND ADJUSTMENT OF THE ATV

CHECKING THE FRONT BRAKE PADS

1. Remove:
 - front wheels
2. Check:
 - brake pads Wear indicator groove ⓐ almost disappearedReplace the brake pads as a set.
Refer to "FRONT AND REAR BRAKES" in chapter 5.

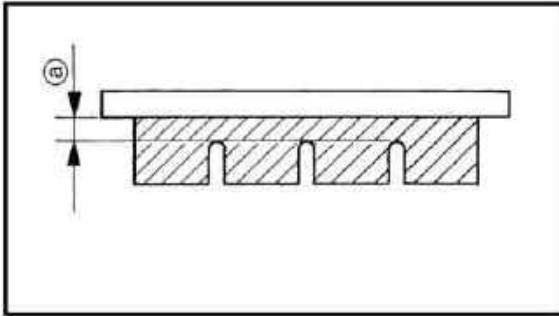

**Brake pad wear limit ⓐ
1.5 mm (0.06 in)**

3. Operate the brake pedal.
4. Install:
 - front wheels

CHECKING THE REAR BRAKE PADS

1. Check:
 - brake padsWear indicator groove ⓐ almost disappeared
Replace the brake pads as a set.
Refer to "FRONT AND REAR BRAKES" in chapter 5.

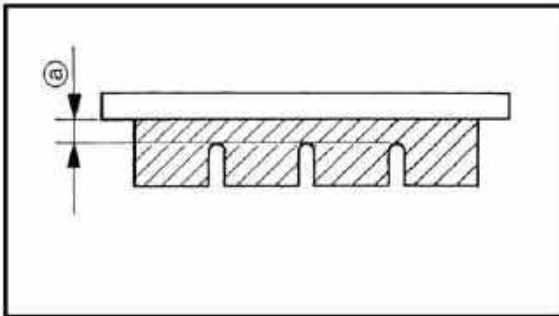

**Brake pad wear limit ⓐ
1.5 mm (0.06 in)**

3. Operate the brake pedal.

MAINTENANCE AND ADJUSTMENT OF THE ATV

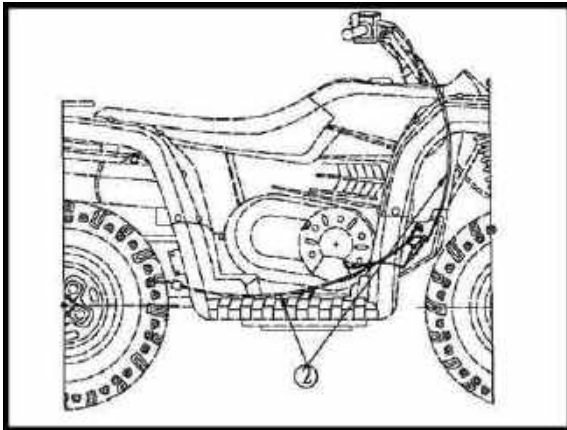
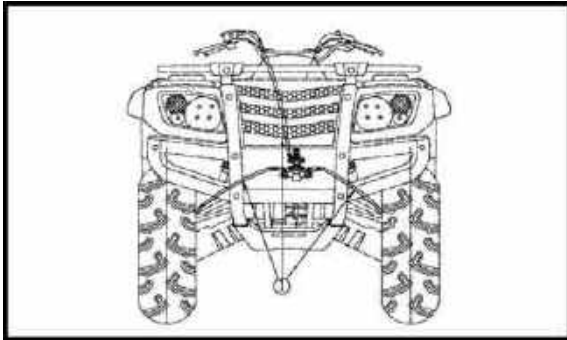

CHECKING THE BRAKE HOSES AND BRAKE PIPES

1. Remove:
 - driver seat
Refer to “SEATS” in chapter 5.
2. Lift the hood up.
3. Check:
 - front brake hoses ①
 - rear brake hoses ②

NOTE:

Hold the vehicle in an upright position and apply the brake pedal.

4. Install driver seat

BLEEDING THE HYDRAULIC BRAKE SYSTEM

WARNING:

Bleed the brake system if:

- *The system has been disassembled.*
 - *A brake hose or brake pipe have been loosened or removed.*
 - *The brake fluid has been very low.*
- The brake operation has been faulty. A loss of braking performance may occur if the brake system is not properly bled.*
-

1. Bleed:
 - brake system
- a. Add the proper brake fluid to the reservoir.
- b. Install the diaphragm. Be careful not to spill any fluid or allow the reservoir to overflow.
- c. Remove the cover of the brake oil pump ① add the moderate brake liquid.

MAINTENANCE AND ADJUSTMENT OF THE ATV

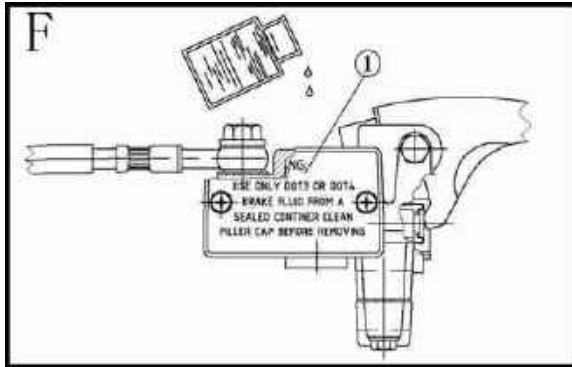

☐ Front

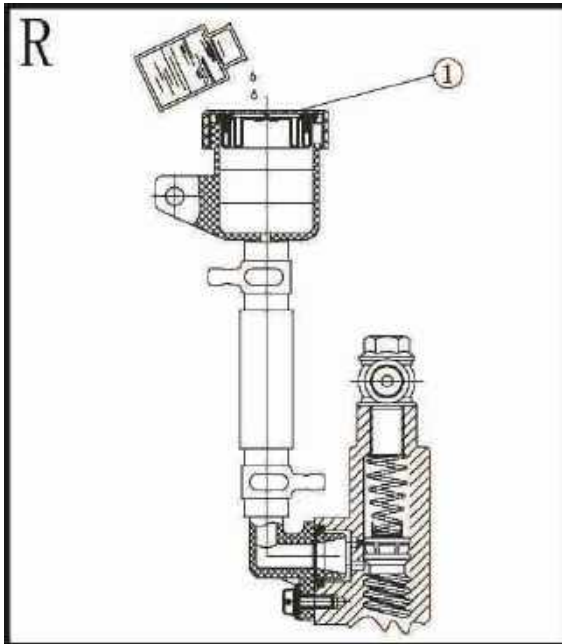

☐ Rear

- d. Place the other end of the hose into a container.
- e. Slowly apply the brake pedal several times.
- f. Push down on the pedal and hold it.
- g. Loosen the bleed screw and allow the pedal to travel towards its limit.
- h. Tighten the bleed screw when the pedal limit has been reached, then release the pedal.
- i. Repeat steps (e) to (h) until all the air bubbles have disappeared from the fluid.
- j. Tighten the bleed screw.

Front brake caliper bleed screw
6 Nm (0.6 m · kg, 4.3 ft · lb)
Rear brake caliper bleed screw
5 Nm (0.5 m · kg, 3.6 ft · lb)

NOTE:

If bleeding is difficult, it may be necessary to let the brake fluid settle for a few hours.

Repeat the bleeding procedure when the tiny bubbles in the system have disappeared.

- k. Add brake fluid to the proper level.

WARNING:

Check the operation of the brake after bleeding the brake system.

MAINTENANCE AND ADJUSTMENT OF THE ATV

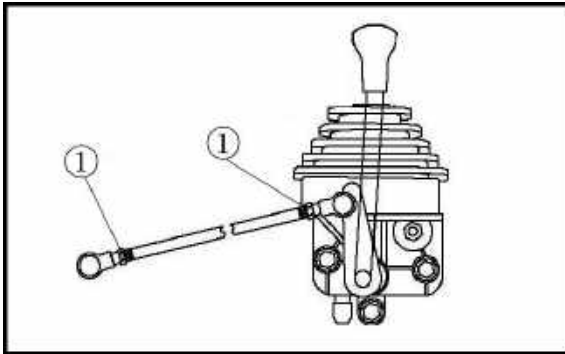
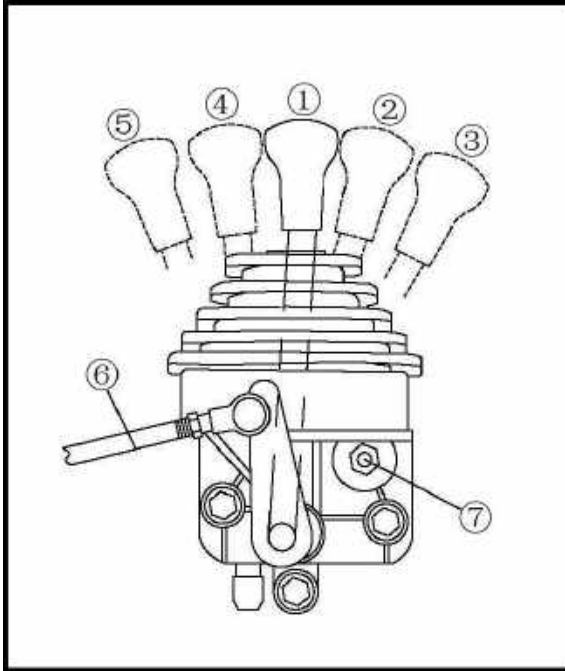

ADJUSTING THE SELECT LEVER SHIFT ROD

- ① Neutral
- ② High
- ③ Low
- ④ Reverse
- ⑤ Parking
- ⑥ Select lever shift rod
- ⑦ Shift control cable

WARNING:

Before shifting, you must stop the vehicle and take your foot off the accelerator pedal.

Otherwise, the transmission may be damaged.

1. Adjust:
 - Select lever shift rod
- a. Make sure the select lever is in NEUTRAL.
- b. Loosen both locknuts ①.

WARNING:

The select lever shift rod locknut (select lever side) has left-handed threads. To loosen the locknut, turn it clockwise.

- c. Tighten the locknuts ①.

ADJUSTING THE BRAKE LIGHT SWITCH

NOTE:

- The brake light switch is operated by movement of the brake pedal.
- The brake light switch is properly adjusted when the brake light comes on just before the braking effect starts.

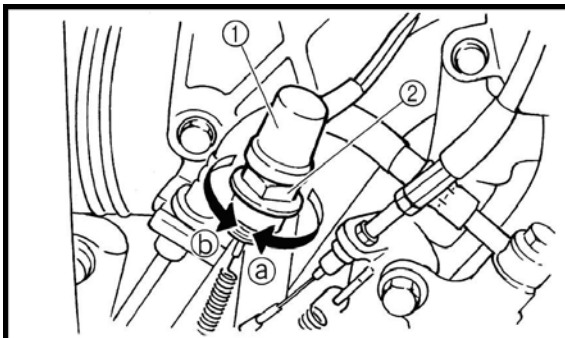

1. Check
 - brake light operation timingIncorrect → Adjust.
2. Adjust:
 - brake light operation timing
- a. Hold the main body ① of the brake light switch so that it does not rotate and turn the adjusting nut ② in direction ① or ② until the brake light comes on at the proper time.

MAINTENANCE AND ADJUSTMENT OF THE ATV

Direction (a)	Brake light comes on sooner.
Direction (b)	Brake light comes on later.

CHECKING THE FINAL GEAR OIL LEVEL

1. Place the vehicle on a level surface.
2. Remove:
 - oil filler plug ①
3. Check:
 - oil levelOil level should be up to the brim of the hole.
Oil level low → Add oil to the proper level.

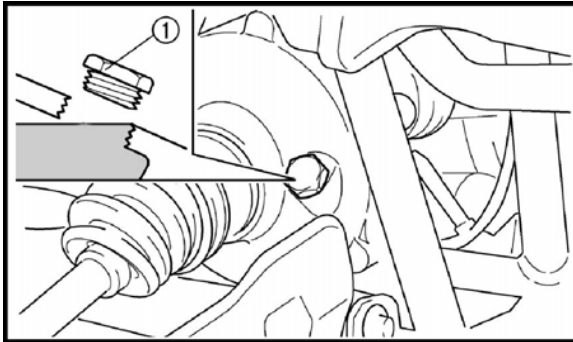

Recommended oil

SAE 80 API "GL-4" Hypoid gear oil

WARNING:

Take care not to allow foreign material to enter the final gear case.

4. Install:
 - oil filler plug

23 Nm (2.3 m · kg, 17 ft · lb)

CHANGING THE FINAL GEAR OIL

1. Place the vehicle on a level surface.
2. Place a container under the final gear case to collect the used oil.
3. Remove:
 - oil filler plug ①
- Fill:
final gear case

Periodic oil change : 0.25 L (0.22 Imp qt)

Total amount: 0.28 L (0.25 Imp qt)

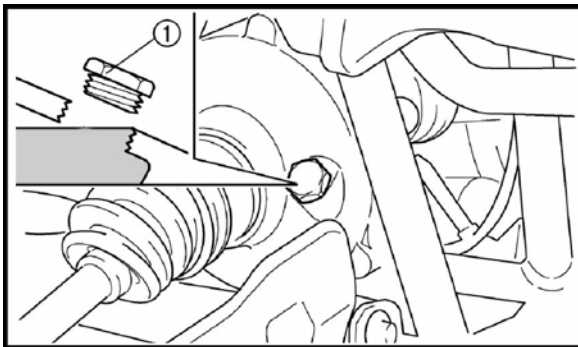

WARNING:

Take care not to allow foreign material to enter the final gear case.

- Install:
oil filler plug

MAINTENANCE AND ADJUSTMENT OF THE ATV

23 Nm (2.3 m · kg, 17 ft · lb)

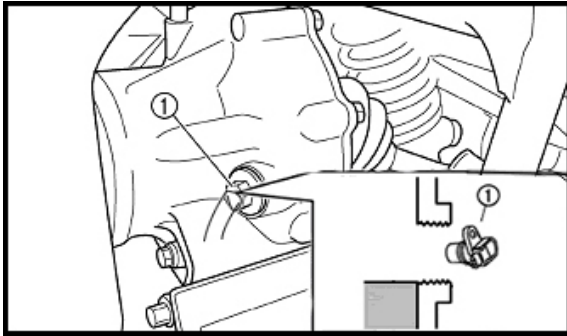

CHECKING THE DIFFERENTIAL GEAR OIL

1. Place the vehicle on a level surface.
2. Remove:
 - oil filler plug ①
3. Check:
 - oil levelOil level should be up to the brim of hole.
Oil level low → Add oil to proper level.

WARNING:

Take care not allow foreign material to enter the differential gear case.

4. Install:
 - oil filler plug

23 Nm (2.3 m · kg, 17 ft · lb)

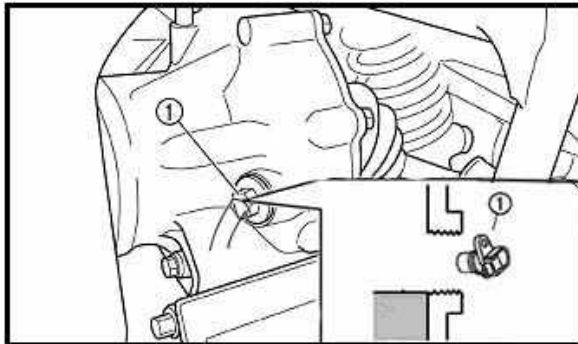

CHANGING THE DIFFERENTIAL GEAR OIL

1. Place the vehicle on a level surface.
2. Place a receptacle under the differential gear case.
3. Remove:
 - oil filler plug ①
4. Drain:
 - differential gear oil
5. Install:
 - drain plug

10 Nm (1.0 m · kg, 7.2 ft · lb)

NOTE:

Check the gasket (drain plug). If it is damaged, replace it with new one.

6. Fill:
 - differential gear case

MAINTENANCE AND ADJUSTMENT OF THE ATV

Periodic oil change

0.32 L (0.28 Imp qt, 0.34 US qt)

Total amount

0.33 L (0.29 Imp qt, 0.35 US qt)

NOTE:

If gear oil is filled to the brim of the oil filler hole, oil may start leaking from the differential gear case breather hose. Therefore, check the quantity of the oil, not its level.

WARNING:

Take care not to allow foreign material to enter the differential gear case.

7. Install:

- oil filler plug

23 Nm (2.3 m · kg, 17 ft · lb)

CHECKING THE CONSTANT VELOCITY JOINT DUST BOOTS

1. Check:

- dust boots ①

Damage → Replace.

Refer to “FRONT CONSTANT VELOCITY JOINTS,” in chapter 5.

Front

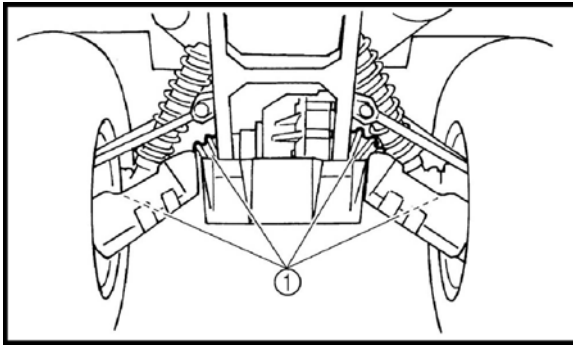

Rear

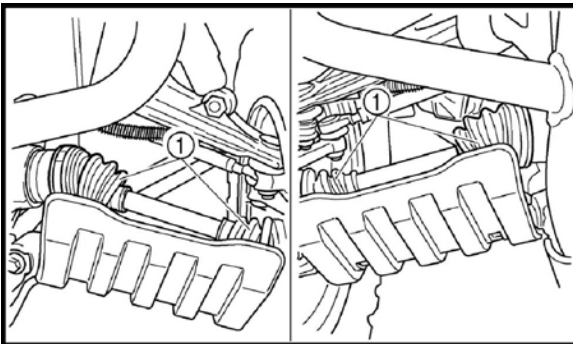

MAINTENANCE AND ADJUSTMENT OF THE ATV

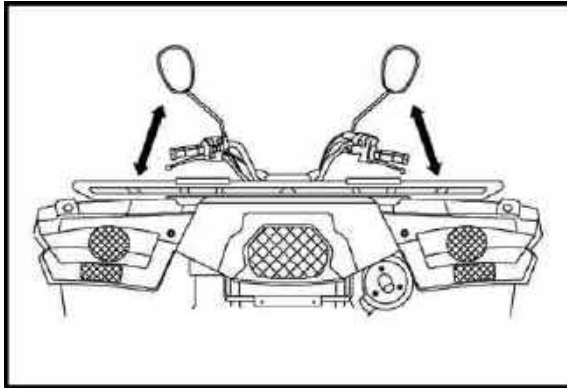

CHECKING THE STEERING SYSTEM

1. place the vehicle on the flat ground .

- Check:

Clamp seat of steering vertical column and sliding bearing on the lower end of steering vertical column, upper & lower and front & rear moving steering bar .If the clearance is too large, replace the sliding bearing.

Refer to section “Steering system” of chapter 5.

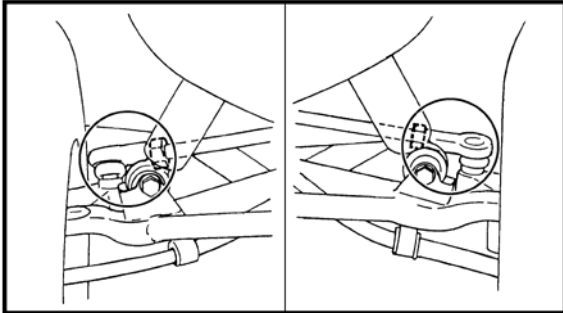

- Check:

tie-rod ends

Ball pin unit of steering tension rod.

Rotate the steering bar leftward and / or rightward,

Then rotate from left to right lightly . If the ball pin

unit of steering tension rod have any vertical

clearance , replace it .

Refer to section “Steering system” of chapter 5.

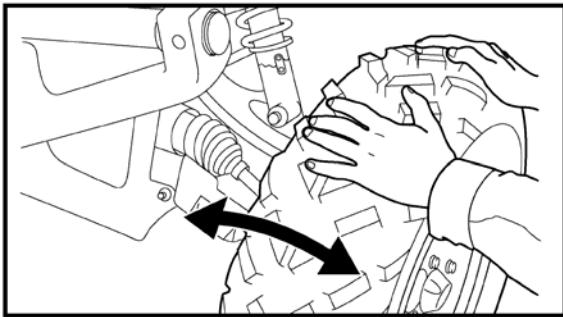

- Check:

Ball joints and/or wheel bearings Move the wheels laterally back and forth. Excessive free play → Replace the front arms (upper and lower) and/or wheel bearings.

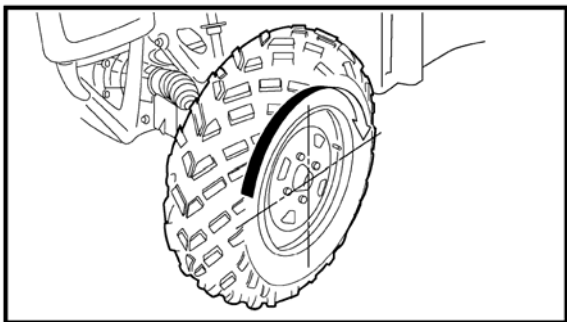

ADJUSTING THE TOE-IN

1. Place the vehicle on a level surface.

2. Measure:

- toe-in

Out of specification → Adjust.

Toe-in

0 ~ 10 mm (0.00 ~ 0.39 in)

(with tires touching the ground)

MAINTENANCE AND ADJUSTMENT OF THE ATV

NOTE:

Before measuring the toe-in, make sure that the tire pressure is correct.

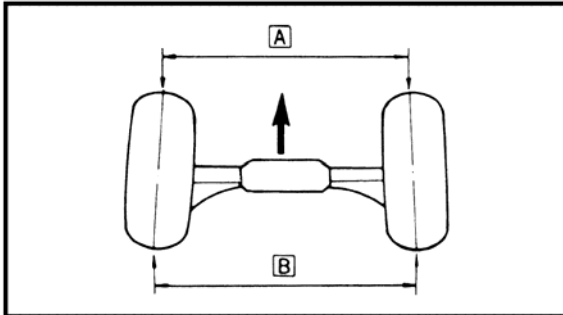

- Mark both front tire tread centers.
- Lift the front end of ATV to keep the front wheel from force.
- Fasten the steering forward. Measure the width between two marks.
- Rotate the front tires 180° until the marks are exactly opposite one another.
- Measure distance B between the marks.
- Calculate the toe-in using the formula given below.

$$\text{Toe-in} = B - A$$

- If the toe-in is incorrect, adjust it.

3. Adjust toe-in

WARNING:

Make sure that left / right tension rods have turned the same turns. Otherwise the ATV will still go left and right even though. Operate the ATV to go forward straightly with steering bar, easily causing to getting out of control and accident. After adjusting the toe-in correctly drive the ATV to move forward a span of distance by fastening the steering bar so as to make sure if the Steering bar is normal, if not, adjust the tension rod left or right within the specification.

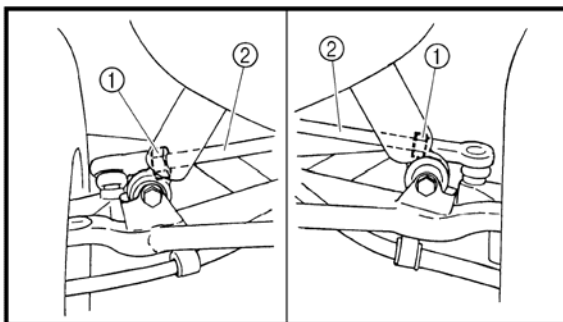

- Mark both tie-rod ends. This reference point will be needed during adjustment.
- Loosen the locknut (tie-rod end) ① on each tie-rod.
- The same number of turns should be given to both the right and left tie-rods ② until the specified toe-in is obtained. This is to keep the length of the rods the same.
- Tighten the rod end locknut on each tie-rod.

Locknut (rod end)

40 Nm (4.0 m · kg, 29 ft · lb)

MAINTENANCE AND ADJUSTMENT OF THE ATV

ADJUSTING THE FRONT SHOCK ABSORBERS

WARNING:

Always adjust both shock absorber spring preload to the same setting. Uneven adjustment can cause poor handling and loss of stability.

NOTE:

The spring preload of the shock absorbers can be adjusted to suit the operator's preference, weight, and the operating conditions.

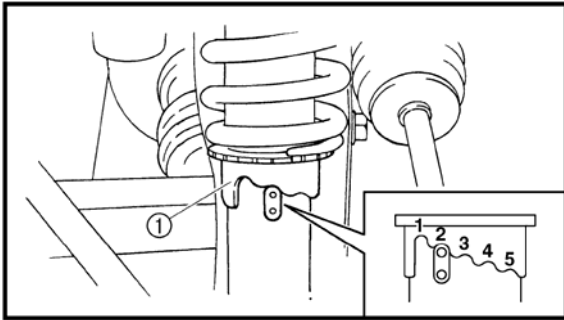

1. Adjust:

- spring preload Turn the adjuster ① to increase or decrease the spring preload.

Standard position: 2

Minimum (Soft) position: 1

Maximum (Hard) position: 5

ADJUSTING THE REAR SHOCK ABSORBERS

WARNING:

Always adjust both shock absorber spring preload to the same setting. Uneven adjustment can cause poor handling and loss of stability.

NOTE:

The spring preload of the shock absorbers can be adjusted to suit the operator's preference, weight, and the operating conditions.

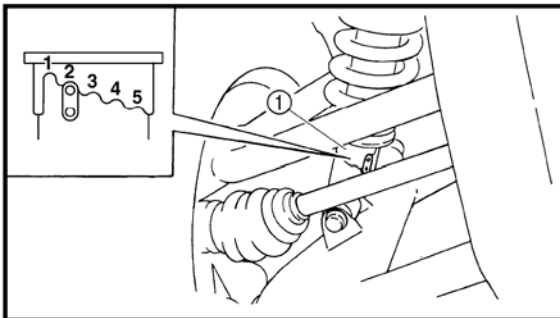

1. Adjust:

- spring preload Turn the adjuster ① to increase or decrease the spring preload.

MAINTENANCE AND ADJUSTMENT OF THE ATV

CHECKING THE TIRES

WARNING:

• **TIRE CHARACTERISTICS**

- a. *Tyre characteristics influence the handling of vehicle's. If other tire combinations are used, they can adversely affect your vehicle's handling characteristics and are therefore not recommended.*

	Size	Type
Front	6PR	25 × 8-12/26 × 9-12
Rear	6PR	25× 10-12/26 × 10-12

• **TIRE PRESSURE**

- a. *Recommended tire pressure*

Front 35Kpa/45Kpa

Rear 35KPa/45Kpa

- b. *Tyre pressure below the minimum specification could cause the tire to dislodge from the rim under severe riding conditions.*

The following are minimums:

Front 31.5Kpa/48.2Kpa

Rear 31.5Kpa/48.2Kpa

- c. *Use no more than*

Front 38Kpa/250Kpa

Rear 38Kpa/250Kpa

- when seating the tire beads. Higher pressure may cause the tire to burst.*

Inflate the tires slowly and carefully.

Fast inflation could cause the tire to burst.

• **MAXIMUM LOADING LIMIT**

- a. *Vehicle loading limit (total weight of cargo, operator, passenger and accessories): 609kg*

- b. *Cargo bed: 60kg*

- c. *Trailer hitch:*

*Pulling load (total weight of trailer and cargo):
100 kg*

Be extra careful of the vehicle balance and stability when towing a trailer.

1. Measure:

- Tire pressure (cold tire pressure) Out of → specification Adjust.

MAINTENANCE AND ADJUSTMENT OF THE ATV

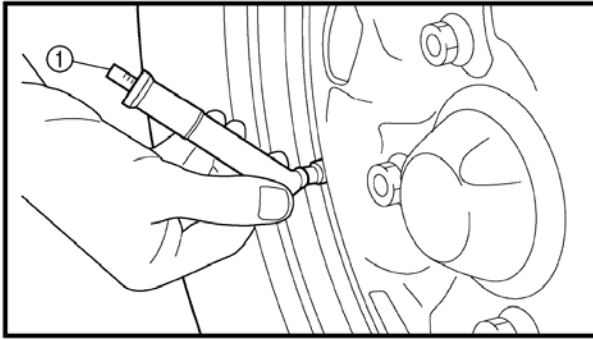

NOTE:

- The tire pressure gauge ① is included as standard equipment.
- If dust or the like is stuck to this gauge, it will not provide the correct readings. Therefore, take two measurements of the tire's pressure and use the second reading.

WARNING:

Uneven or improper tire pressure may adversely affect the handling of this vehicle and may cause loss of control.

- *Maintain proper tire pressures.*
- *Set tire pressures when the tires are cold.*
- *Tire pressures must be equal in both front tires and equal in both rear tires.*

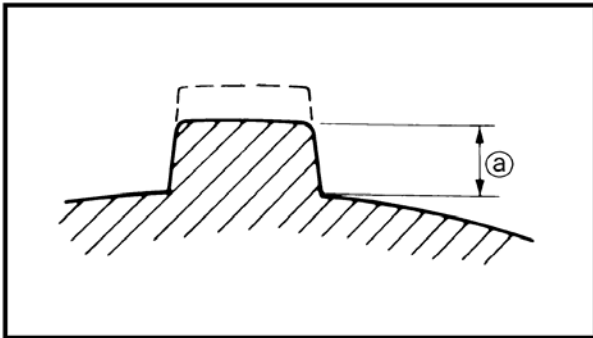

2. Check:

- tire surfaces

Wear/damage@ → Replace.

Tire wear limit @

Front and rear: 3.0 mm (0.12 in)

WARNING:

It is dangerous to ride with a worn-out tire.

When tire wear is out of specification, replace the tire immediately.

CHECKING THE WHEELS

1. Check:

- Wheels ① Damage/bends → Replace.

NOTE:

Always balance the wheel when a tire or wheel has been changed or replaced.

WARNING:

- *Never attempt even small repairs to the wheel.*
- *Ride conservatively after installing a tire to allow it to seat itself properly on the rim.*

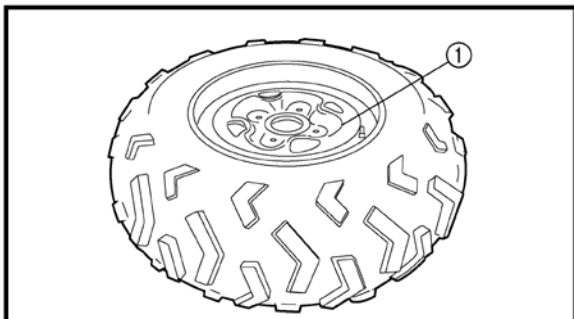

MAINTENANCE AND ADJUSTMENT OF THE ATV

CHECKING AND LUBRICATING THE CABLES

WARNING:

A damaged cable sheath may cause corrosion and interfere with the cable movement. An unsafe condition may result so replace a damaged cable as soon as possible.

1. Check:

- cable sheath Damage → Replace.
- cable operation Unsmooth operation → Lubricate or replace.

NOTE:

Hold the cable end up and apply several drops of lubricant to the cable.

2. Apply:

- lithium-soap-based grease (onto end of the cable)

MAINTENANCE AND ADJUSTMENT OF THE ATV

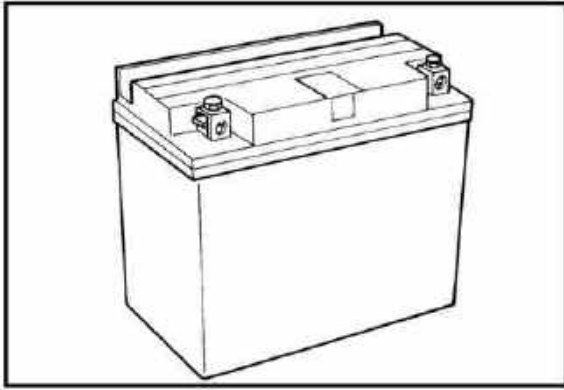

ELECTRICAL

CHECKING AND CHARGING THE BATTERY

WARNING:

Batteries generate explosive hydrogen gas and contain electrolyte which is made of poisonous and highly caustic sulfuric acid.

Therefore, always follow these preventive measures:

- *Wear protective eye gear when handling or working near batteries;*
- *Charge batteries in a well-ventilated area;*
- *Keep batteries away from fire, sparks or open flames (e.g., welding equipment, lighted cigarettes);*
- *Do not smoke when charging or handling batteries;*
- *Keep batteries and electrolyte out of reach of children;*
- *Avoid bodily contact with electrolyte as it can cause severe burns or permanent eye injury;*

First aid in case of bodily contact:

External

- *Skin — Wash with water;*
- *Eyes — Flush with water for 15 minutes and get immediate medical attention;*

Internal

Drink large quantities of water or milk followed with milk of magnesia, beaten egg or vegetable oil. Get immediate medical attention.

WARNING:

- *This is a sealed battery. Never remove the sealing caps because the balance between cells will not be maintained and battery performance will deteriorate;*
- *Charging time, charging amperage and charging voltage for an MF battery are different from those of conventional batteries. The MF battery should be charged as explained in the charging method*

MAINTENANCE AND ADJUSTMENT OF THE ATV

illustrations. If the battery is overcharged, the electrolyte level will drop considerably;

- *Therefore, take special care when charging the battery.*

NOTE:

Since MF batteries are sealed, it is not possible to check the charge state of the battery by measuring the specific gravity of the electrolyte. Therefore, the charge of the battery has to be checked by measuring the voltage at the battery terminals.

1. Remove:
 - battery case cover;
 - disconnect;
battery leads

NOTE:

First, disconnect the negative battery lead ①, and then the positive battery lead ②.

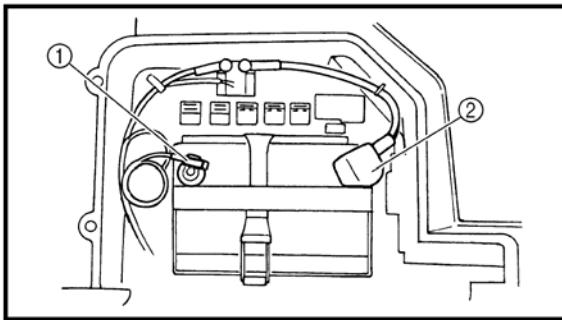

- Remove;
battery
 - Check;
battery charge
- a. Connect a pocket tester to the battery terminals.

Positive tester probe → positive battery terminal
Negative tester probe → negative battery terminal

NOTE:

- The charge state of an MF battery can be checked by measuring its open-circuit voltage (i.e., the voltage when the positive terminal is disconnected).
 - No charging is necessary when the open-circuit voltage equals or exceeds 12.8 V.
-

b. Check the charge of the battery, as shown in the charts and the following example.

Example

MAINTENANCE AND ADJUSTMENT OF THE ATV

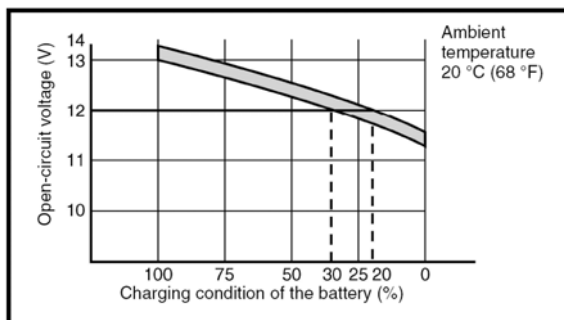
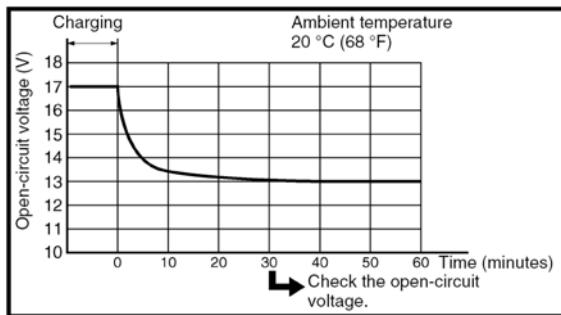
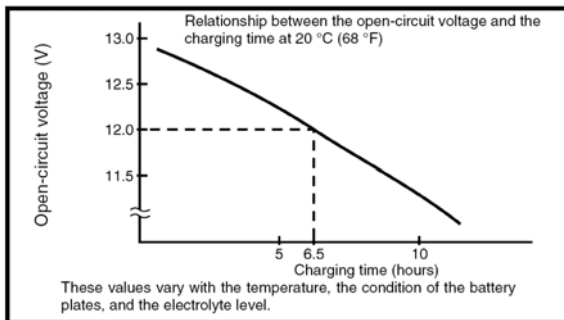
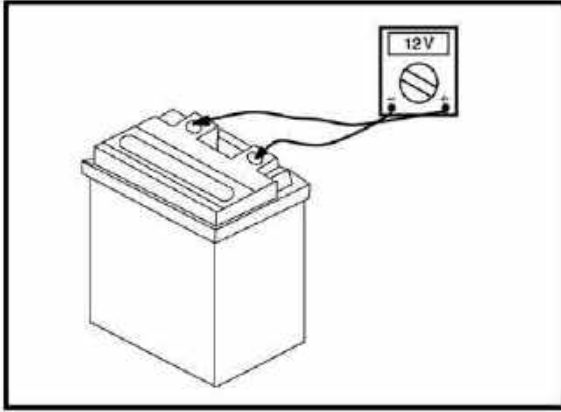

- c. Open-circuit voltage = 12.0 V
- d. Charging time = 6.5 hours
- e. Charge of the battery = 20 ~ 30%

2. Charge:

- battery (refer to the appropriate charging method illustration) .

WARNING:

Do not quick charge a battery.

NOTE:

- Never remove the MF battery sealing caps.
- Do not use a high-rate battery charger since it forces a high-amperage current into the battery quickly and can cause battery overheating and battery plate damage.
- If it is impossible to regulate the charging current on the battery charger, be careful not to overcharge the battery.
- When charging a battery, be sure to remove it from the vehicle. (If charging has to be done with the battery mounted on the vehicle, disconnect the negative battery lead from the battery terminal).
- To reduce the chance of sparks, do not plug in the battery charger until the battery charger leads are connected to the battery.
- Before removing the battery charger lead clips from the battery terminals, be sure to turn off the battery charger.
- Make sure the battery charger lead clips are in full contact with the battery terminal and that they are not shorted. A corroded battery charger lead clip may generate heat in the contact area and a weak clip spring may cause sparks.
- If the battery becomes hot to the touch at any time during the charging process, disconnect the battery charger and let the battery cool before reconnecting it. Hot batteries can explode!
- As shown in the following illustration, the open-circuit voltage of an MF battery stabilizes about 30 minutes after charging has been completed. Therefore, wait 30 minutes after charging is completed before measuring the open-circuit voltage.

Charging method using a variable-current

MAINTENANCE AND ADJUSTMENT OF THE ATV

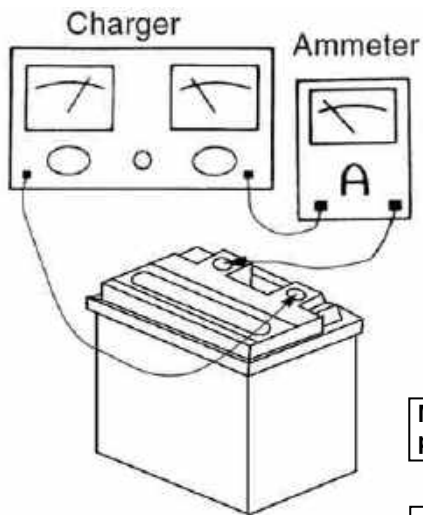

(voltage) charger

NOTE:

- Leave the battery unused for more than 30 minutes before measuring its open-circuit voltage.
- Set the charging voltage to 16 ~17 V. (If the charging voltage is lower, charging will be insufficient, if it is higher, the battery will be over-charged.)

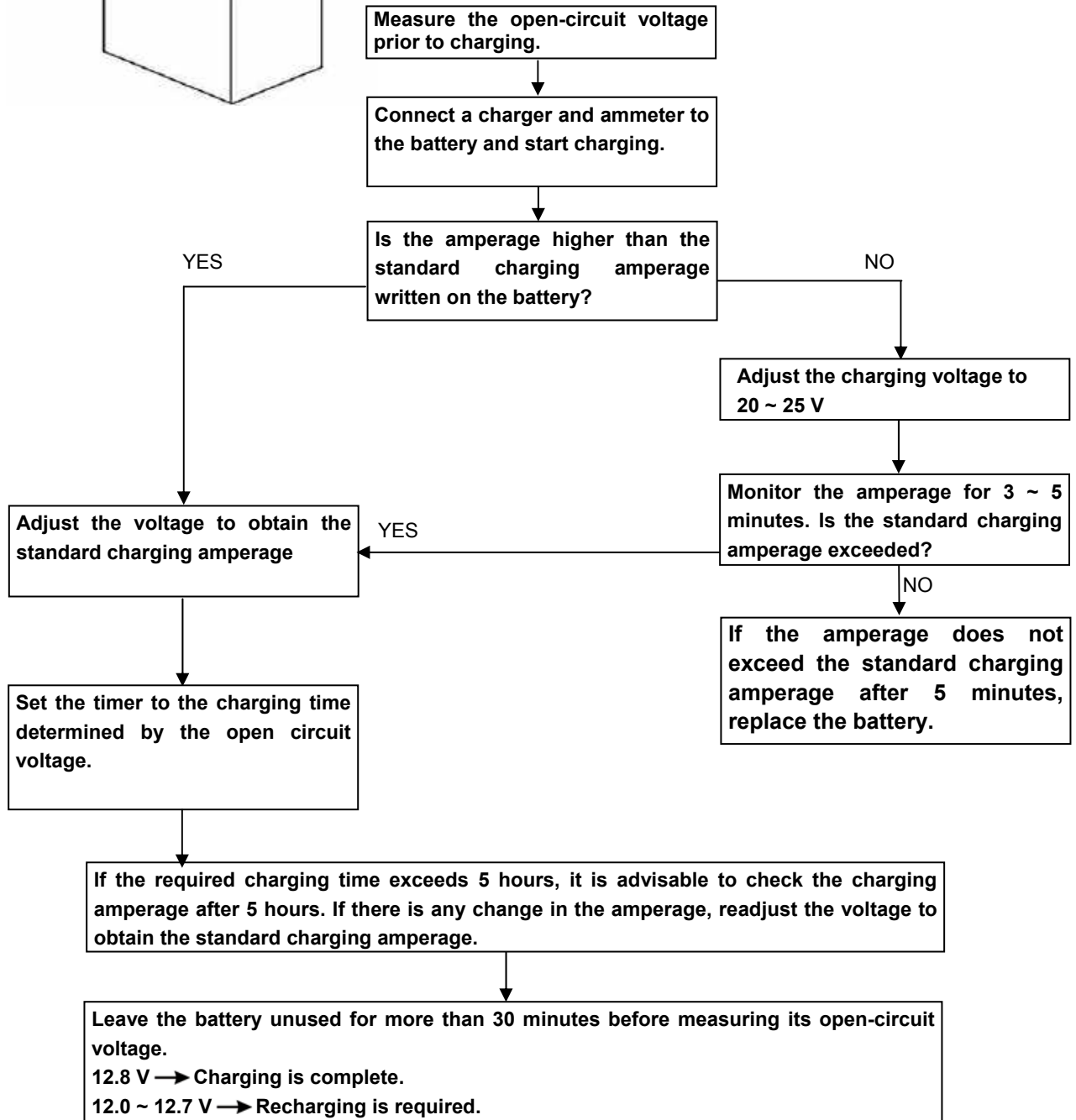

MAINTENANCE AND ADJUSTMENT OF THE ATV

Charging method using a constant voltage charger

NOTE:

Leave the battery unused for more than 30 minutes before measuring its open-circuit voltage.

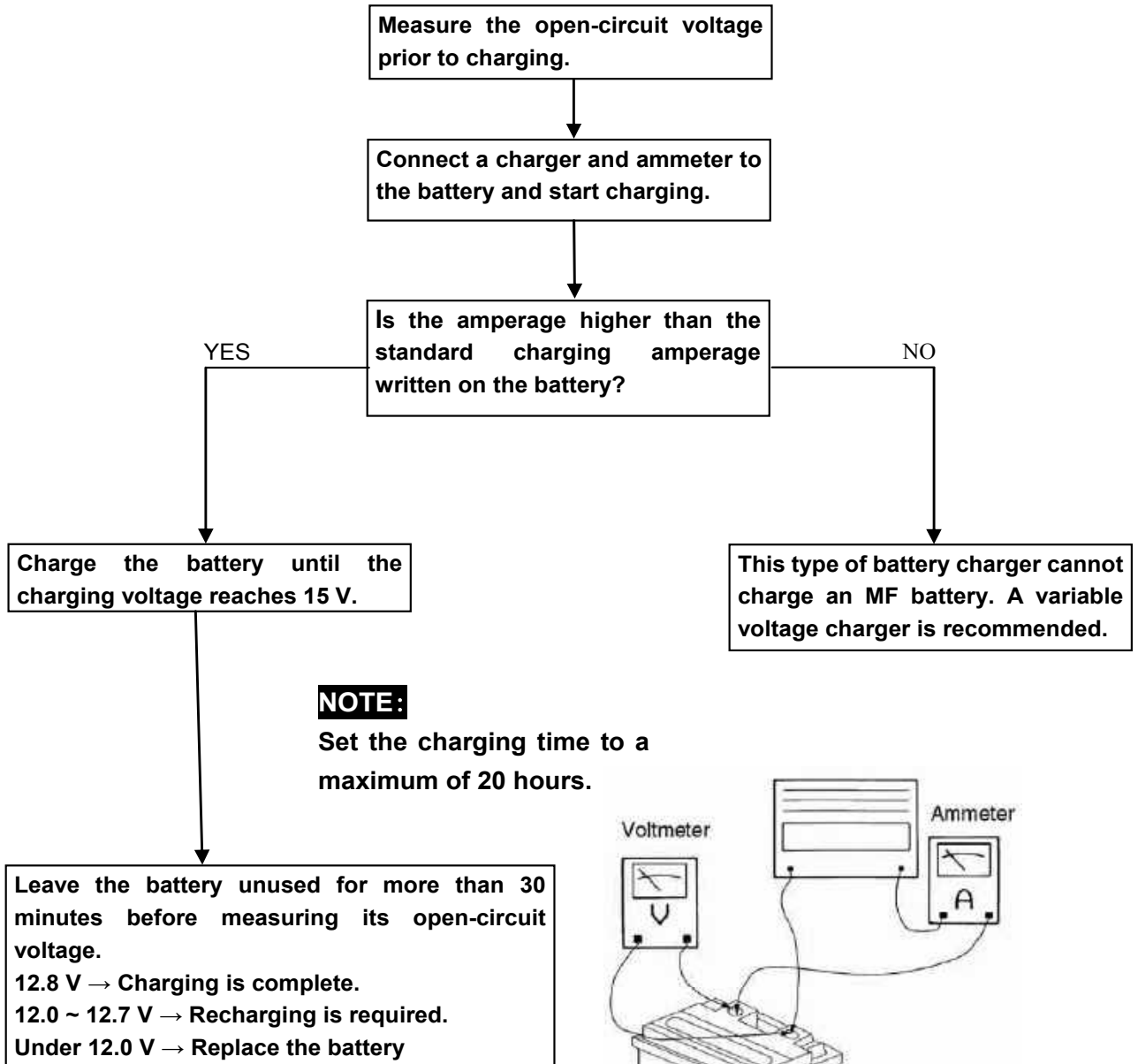

MAINTENANCE AND ADJUSTMENT OF THE ATV

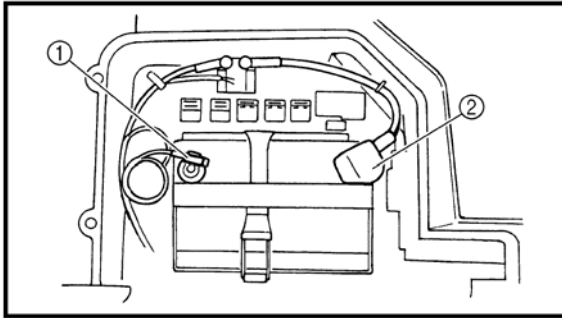

NOTE:

Constant amperage chargers are not suitable for charging MF batteries.

3. Install:

- battery
- Connect:
battery leads

NOTE:

First, connect the positive battery lead ①, and then the negative battery lead ②.

• Check:

Battery terminals Dirt → Clean with a wire brush.

Loose connection → Connect properly.

• Lubricate:

battery terminals

4. Install:

- battery case cover

5. Close the hood.

CHECKING THE FUSES

NOTE:

Always turn off the main switch when checking or replacing a fuse. Otherwise, a short circuit may occur.

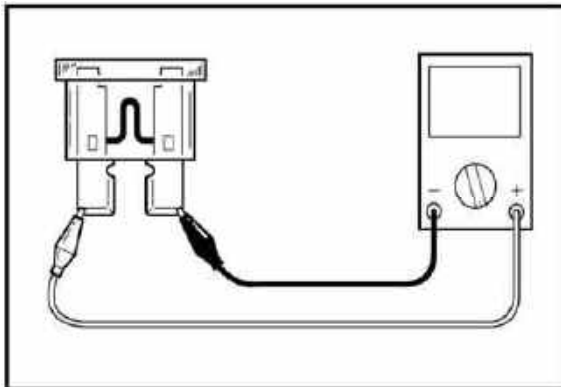

1. Remove:

- battery case cover

2. Check:

- fuses

a. Connect the pocket tester to the fuse and check it for continuity..

NOTE:

Set the tester to the “ $\Omega \times 1$ ” position.

b. If the tester indicates “ ∞ ”, replace the fuse.

3. Replace:

- blown fuse

a. Turn off the ignition.

b. Install a new fuse of the proper amperage.

c. Turn on switches to verify operation of the related

MAINTENANCE AND ADJUSTMENT OF THE ATV

electrical devices.

- d. If the fuse immediately blows again, check the electrical circuit.

Description	Current rating	Quantity
Main	30 A	1
Lighting system fuse	15 A	1
Ignition	10 A	1
Terminal (Auxiliary DC jack)	10 A	1
4WD(Four wheel drive)	5 A	1
Signaling system fuse	10 A	1
Backup fuse	10 A	1
Reserve	30 A	1
Reserve	15 A	1
Reserve	10 A	1
Reserve	5 A	1

WARNING:

ever use a fuse with a rating other than that specified. Never use other materials in place of a fuse. An improper fuse may cause extensive damage to the electrical system, a malfunction of the lighting and ignition systems and could possibly cause a fire.

4. Install:

- battery case cover

MAINTENANCE AND ADJUSTMENT OF THE ATV

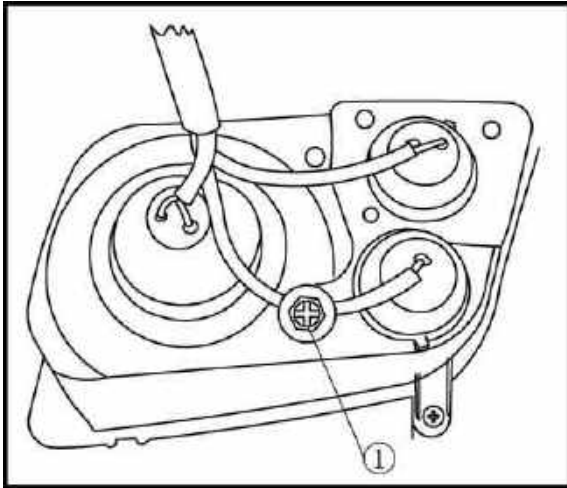

ADJUSTING THE HEADLIGHT BEAM

1. Adjust:

- headlight beam (vertically)
- turn the adjuster ① in or out

Turning in	Headlight beam raised.
Turning out	Headlight beam lowered.

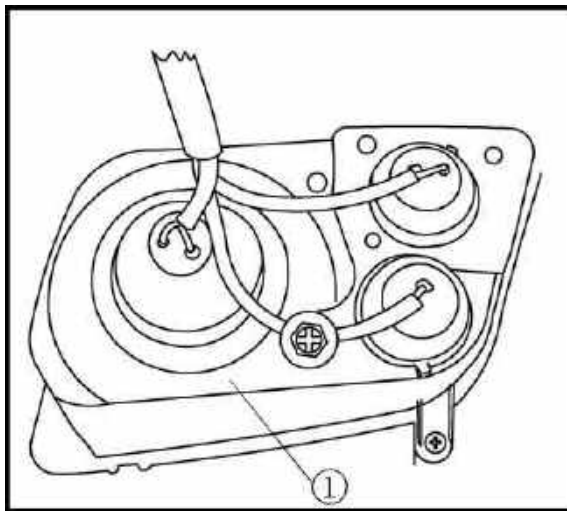

CHANGING THE HEADLIGHT BULB

Remove:

- Lift the hood up.
- headlight bulb holder cover ①

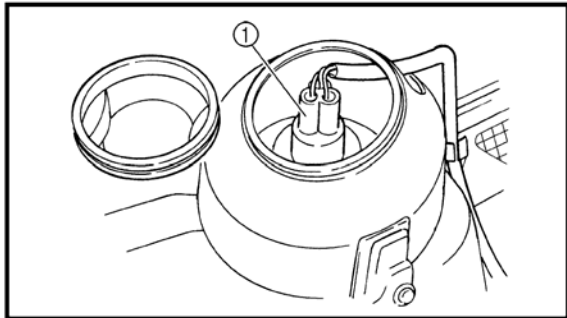

- headlight bulb holder (with bulb) ①
- bulb

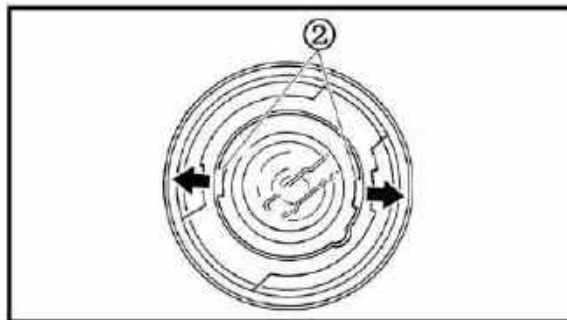

NOTE:

Remove the defective bulb by unhooking the headlight bulb holder tabs ②

WARNING:

Keep flammable products and your hands away from the bulb while it is on, since it will be hot. Do not touch the bulb until it cools down.

MAINTENANCE AND ADJUSTMENT OF THE ATV

NOTE:

Avoid touching the glass part of the bulb. Keep it free from oil; otherwise, the transparency of the glass, life of the bulb, and luminous flux will be adversely affected. If oil gets on the bulb, thoroughly clean it with a cloth moistened with alcohol or lacquer thinner.

- headlight bulb holder (with bulb)
- headlight bulb holder cover
- Close the hood.

CHANGING THE TAIL/BRAKE LIGHT BULB

1. Remove:

- Rear panel
- Tail/brake light bulb holder(with bulb)①
- Secure the new bulb with the tail/brake light bulb holder.
- tail/brake light bulb holder (with bulb) ①
- bulb

NOTE:

Turn the bulb holder counterclockwise and remove the defective bulb.

WARNING:

Keep flammable products and your hands away from the bulb while it is on, since it will be hot. Do not touch the bulb until it cools down.

2. Install:

- bulb new
- Secure the new bulb with the tail/brake light bulb holder.

NOTE:

Avoid touching the glass part of the bulb. Keep it free from oil; otherwise, the transparency of the glass, life of the bulb, and luminous flux will be adversely affected. If oil gets on the bulb, thoroughly clean it with a cloth moistened with alcohol or lacquer thinner.

- tail/brake light bulb holder (with bulb)
- bed panel

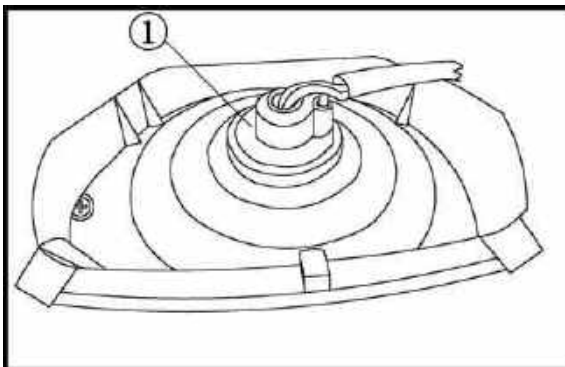
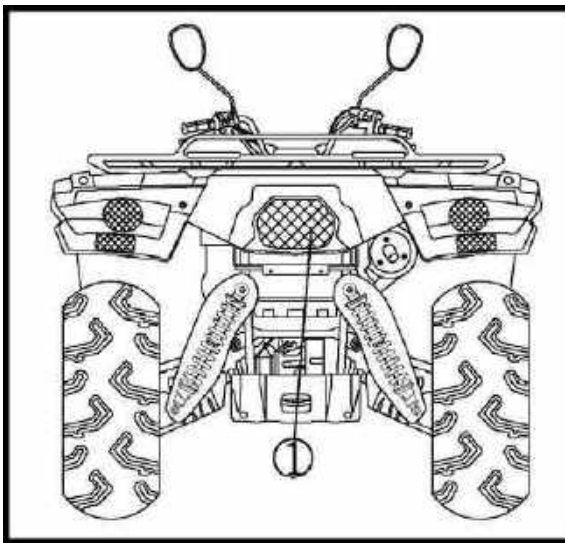

ENGINE

ENGINE

ENGINE NOTE

1. Make sure the components, oil, adhesive, sealant are from the company or recommended.
2. Original removal oil seal, gasket, O-ring, piston ring can not be re-assembled again, make sure all these parts are new.
3. Pay attention to keep dismantled parts orderly, make sure their original positions for reassembling.
4. Prevent dismantled parts damaged, clean before measure and assembly, remove the oil with compressed air. Paint the rotating and sliding parts with specified oil, paint or inject designated location with recommended grease.
5. Bolts and nuts tightening order: pre-fixed bolts, and then tighten them from the large diameter to small diameter, from inside to outside by diagonal points 2 or 3 times to the specified torque. Opposite order is for removing bolts and nuts.
6. Make sure sealing bolt (with the sealant) must be replaced
7. Make sure to use new bearing when remove assembly set up by pressure.
8. Determined axial and radial clearance of inner and outer bearing ring by touch, new bear should be replaced if the clearance is too large or non-rotating flexible.
9. Bearing assembly directions: bearing logo should be visible assemblies; confirm bearing outer ring rotate and move reliably and flexibly when assemble bearing by pressure.
10. Oil seal assembly: pay attention to seal side is in the side of oil, logo side outwards, seal side be painted with grease, and make sure seal side without scratch and oil seal be vertical.
11. Before assembly, sealing material attached to all engine covers and crank case combination surface should be cleaned.
12. Before assembly engine, be familiar with engine lubrication circuit, clean and blow oil circuit.

ENGINE

ENGINE REMOVAL

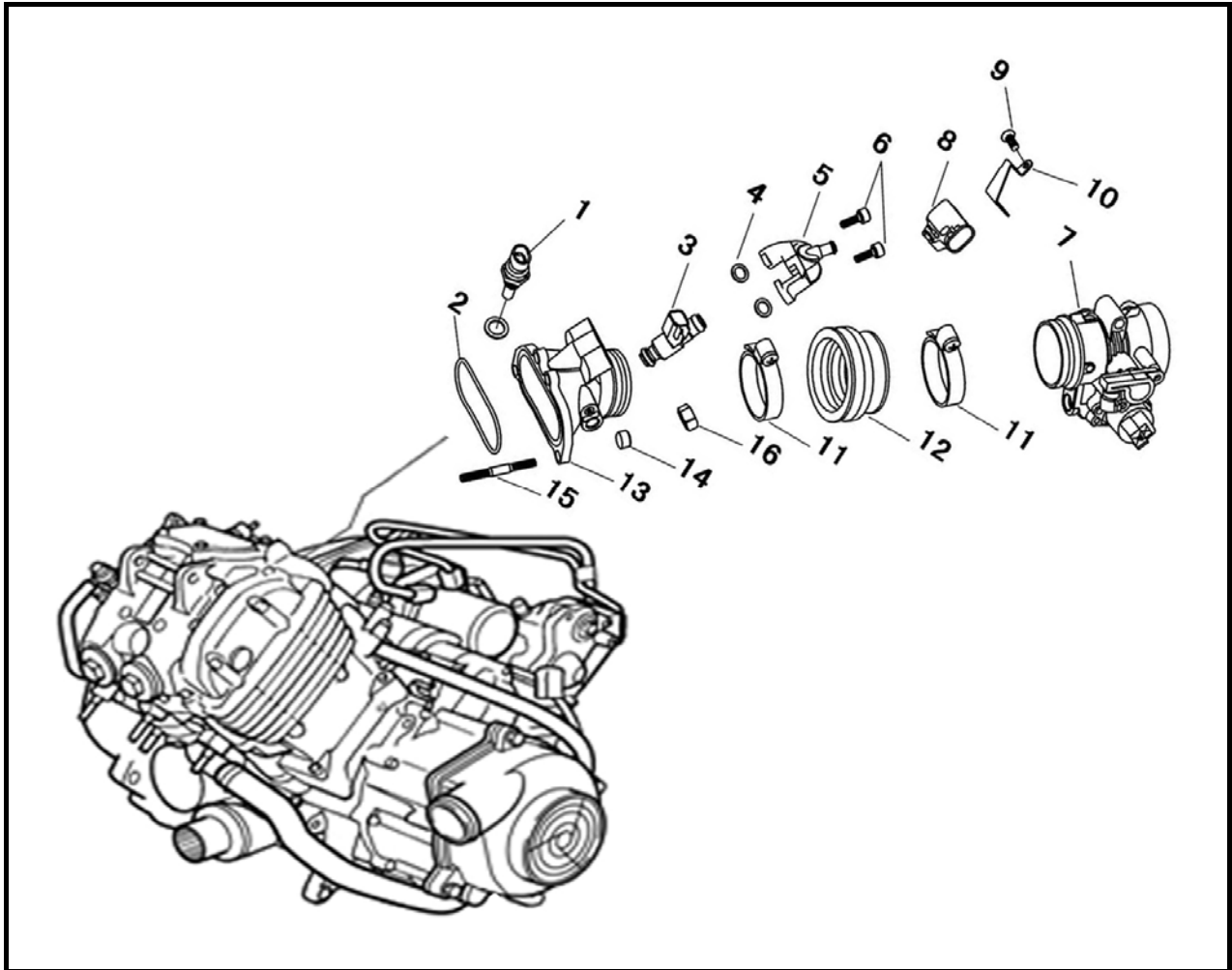

No.	Part Name	Qty	Remarks
	Removing Throttle and intake manifold.		Remove the parts in the order listed.
1	Water temperature sensor	1	
2	O-ring	1	
3	Fuel injection	1	
4	Washer $\phi 6 \times 2$	2	
5	Seat fuel injection	1	
6	Bolt M6 \times 20	2	
7	Ducting dampers	1	
8	Inlet Temperature/pressure sensor	1	
9	Bolt M4 \times 8	1	
10	Pressure plate tmap	1	
11	Clip 50-70	2	
12	Inlet joint head	1	

ENGINE

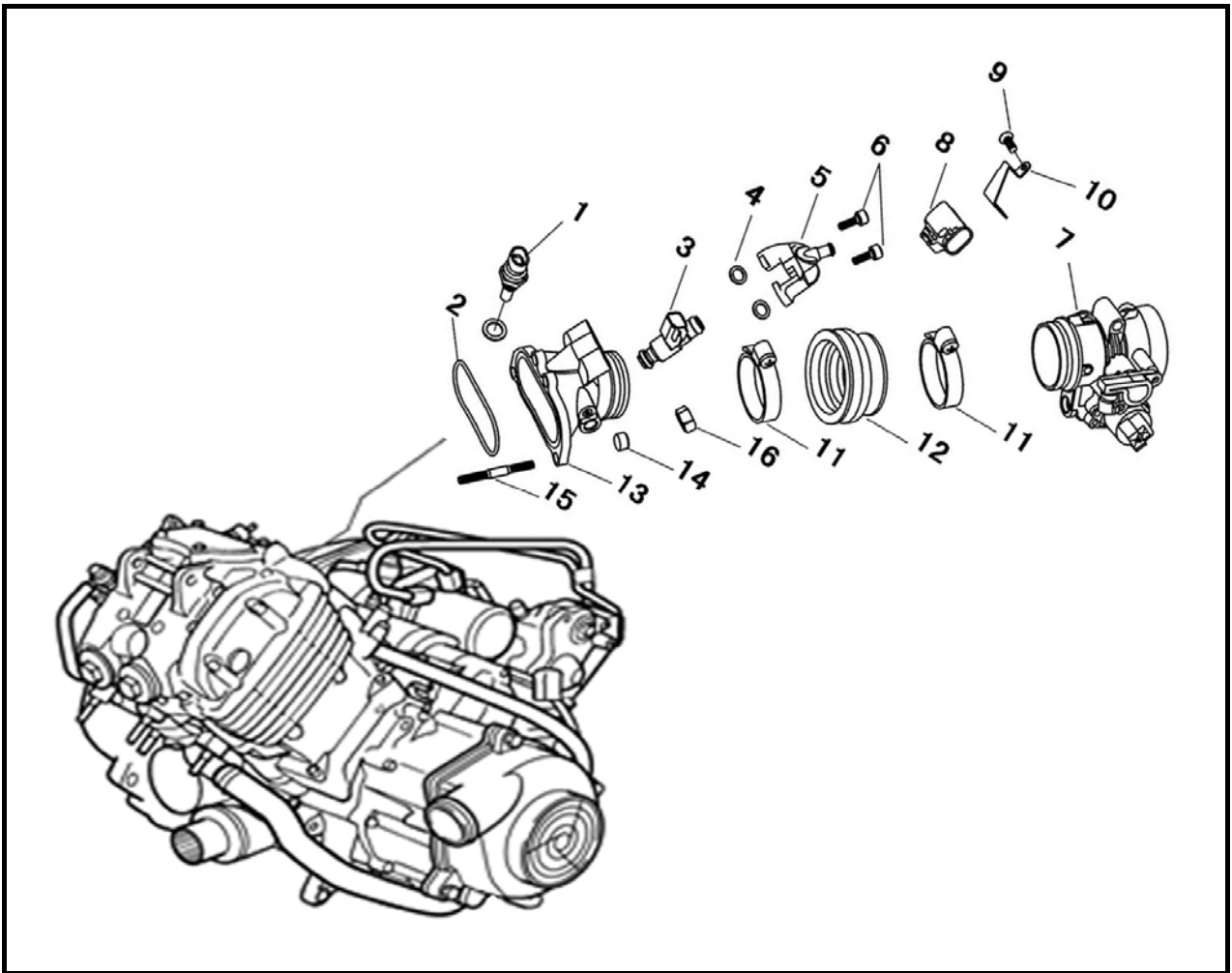

No.	Part Name	Qty	Remarks
13	Inlet pipe	1	For installation, reverse the removal procedure.
14	Bush inlet pipe	4	
15	Bolt stud	4	
16	Nut M6	4	

ENGINE

1、 NOTE

- Removing the drain plug

NOTE:

Before remove drain plug, please prepare vessel for containing oil and cotton yarn.

2、 INSTALL

- Install intake manifold
- Install intake manifold bolt
- Install throttle joint
- Install throttle

NOTE:

When installed, don't make an object from the intake fell into the cabinet.

ENGINE

CYLINDER HEAD

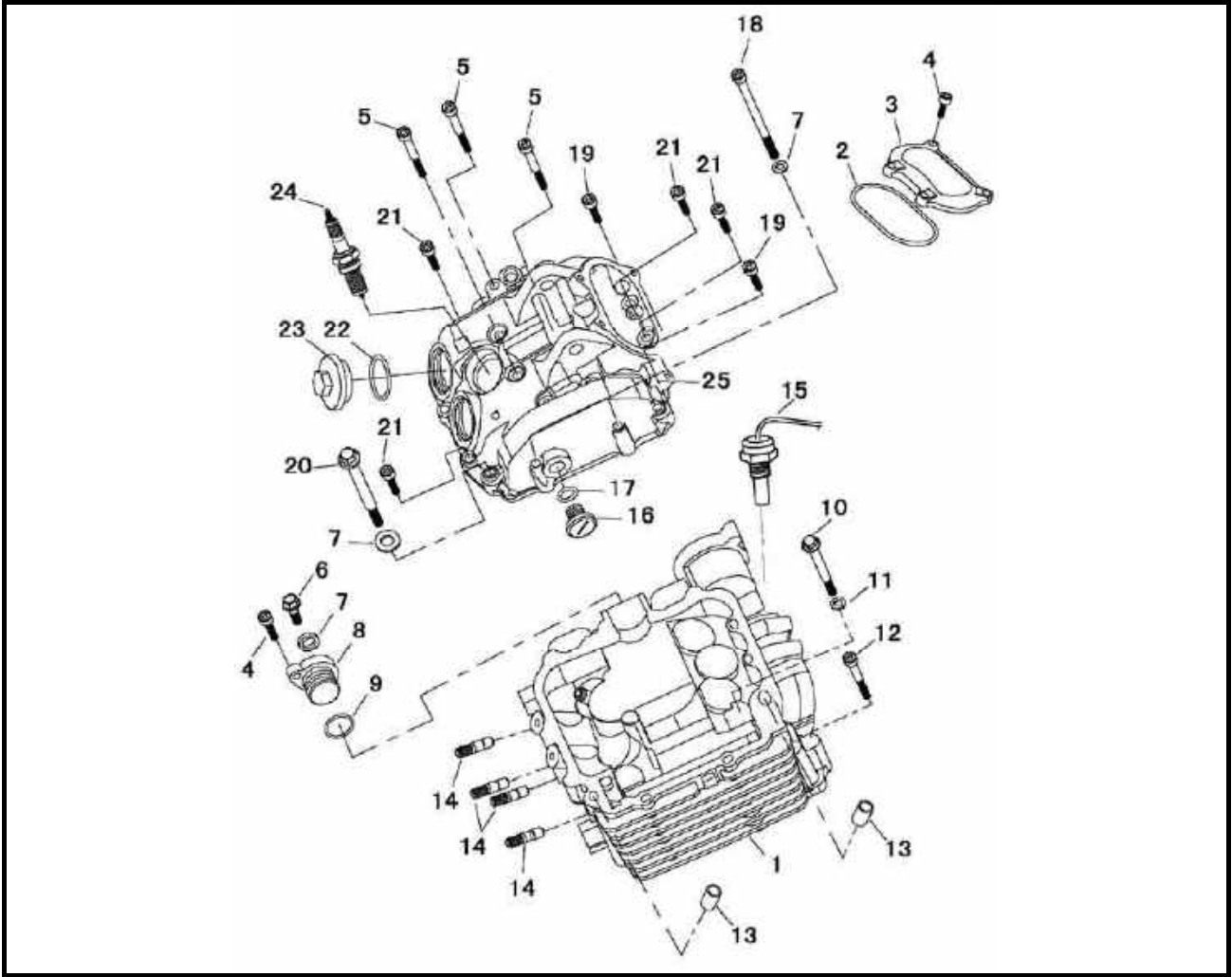

No.	Part Name	Qty	Remarks
	Removing the cylinder head		Remove the parts in the order listed.
1	Cylinder head comp	1	
2	O-Ring 71.5x3	1	
3	Inlet valve cover	1	
4	Cylinder screw m6x20,Inner	5	
5	Cylinder screw m6x55,Inner	7	
6	Flange bolt M6x12	1	
7	Aluminum washer φ6xφ12x1.5	11	
8	Camshaft end cover	1	
9	O-ring 18.7x2.45	1	
10	Bolt M9x109	4	
11	Washer φ10xφ19x2	4	

ENGINE

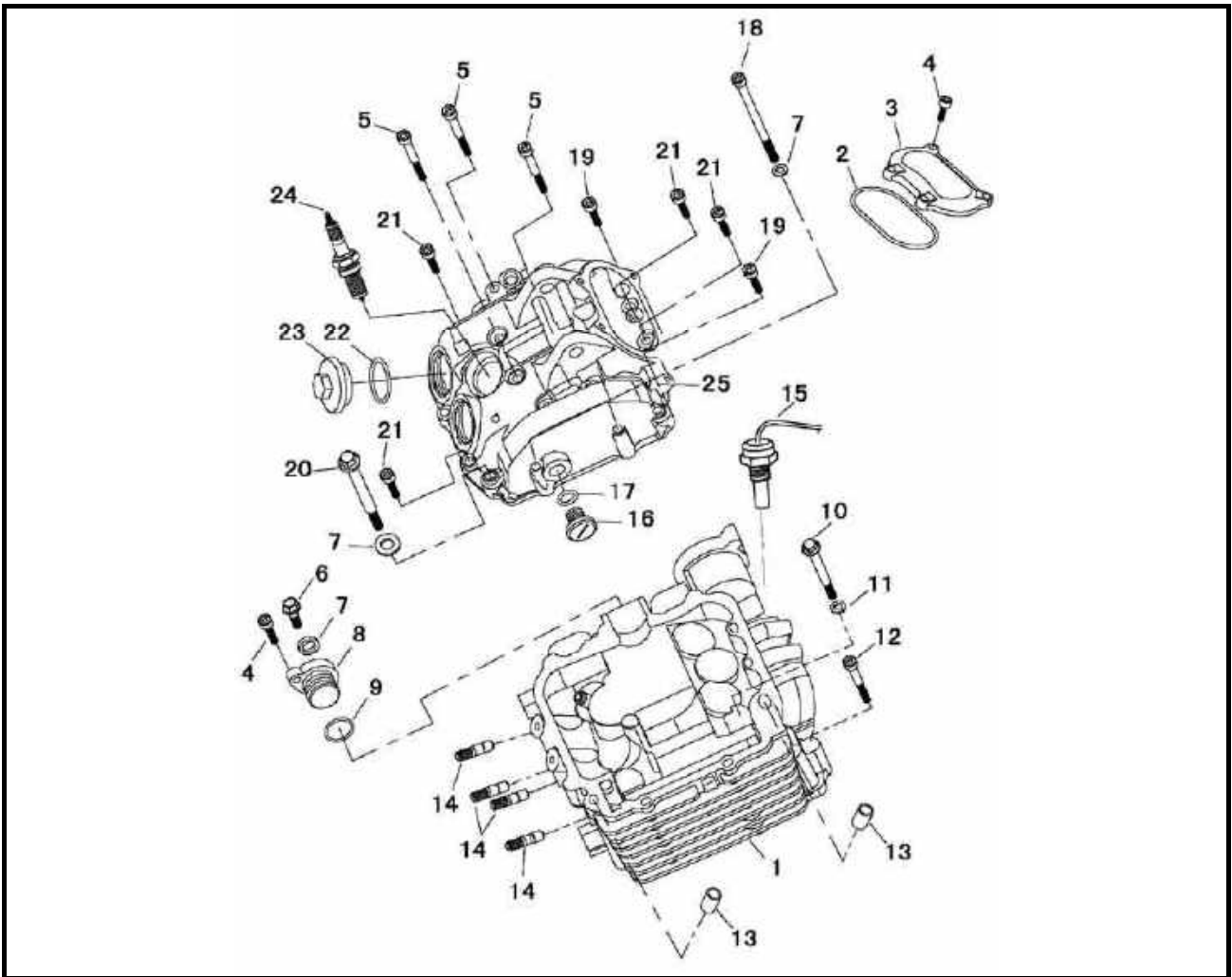

No.	Part Name	Qty	Remarks
12	Dowel pin ϕ 10×16	2	
13	Stud bolt M8×45	4	
14	Water temperature alarm switch	1	
15	Hand hole cover	1	
16	O-Ring 13.4×2.35	1	
17	Cylinder screw M6×130,Inner	2	
18	Cylinder screw M6×40,Inner	2	
19	Cylinder screw M6×115,Inner	1	
20	Cylinder screw M6×25,Inner	5	
21	O-ring 32.7×3.1	2	
22	Dowel pin ϕ 10×16	2	
23	Outlet valve Cover	2	
			For installation, reverse the removal procedure.

ENGINE

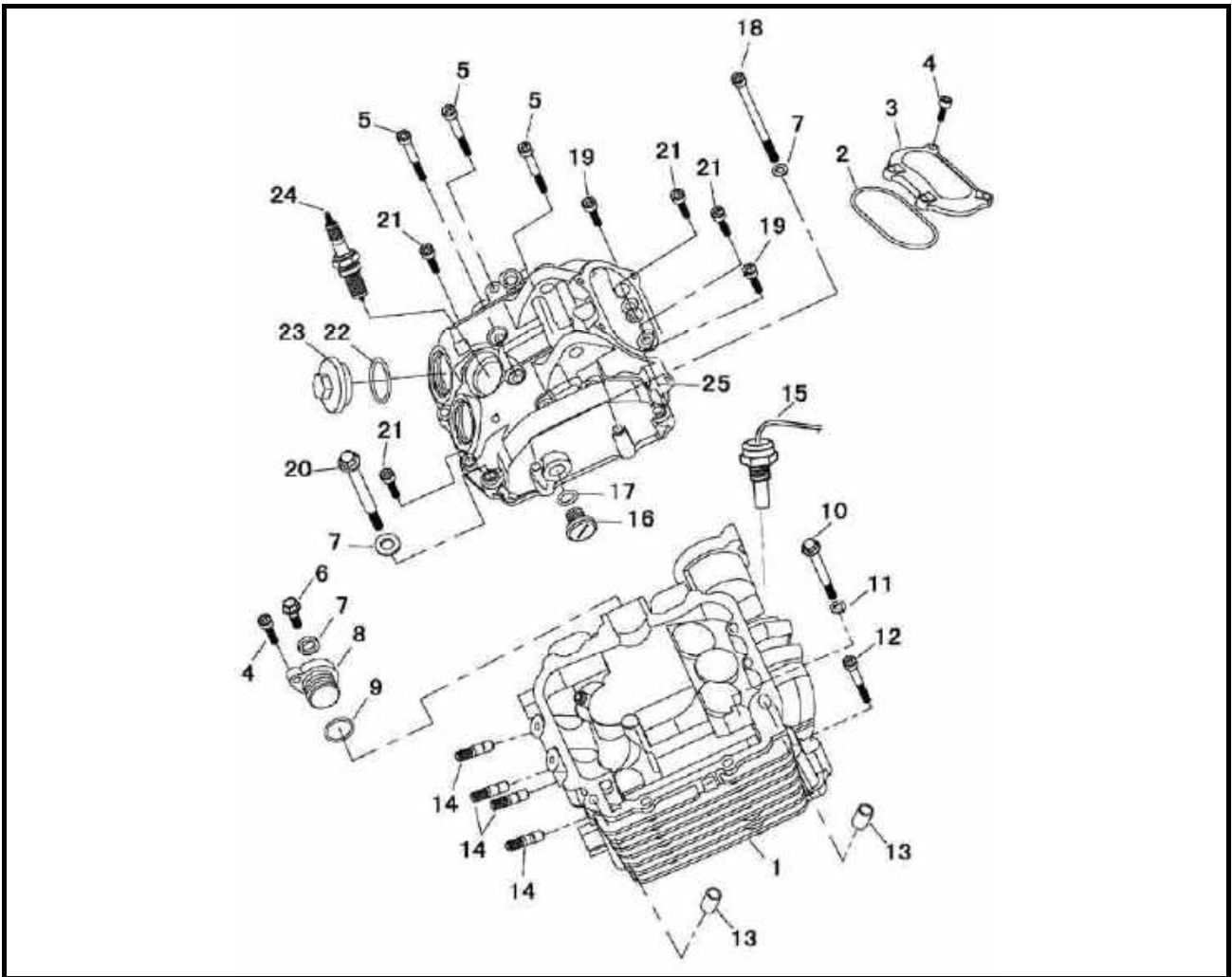

No.	Part Name	Qty	Remarks
24	Spark plug(NGK DCPR7E)	1	For installation, reverse the removal procedure.
25	Cylinder head cover	1	

ENGINE

1、 CHECK

1). Checking the valve clearance

- Valve clearance

Refer to “ADJUSTING THE VALVE CLEARANCE” in chapter 3.

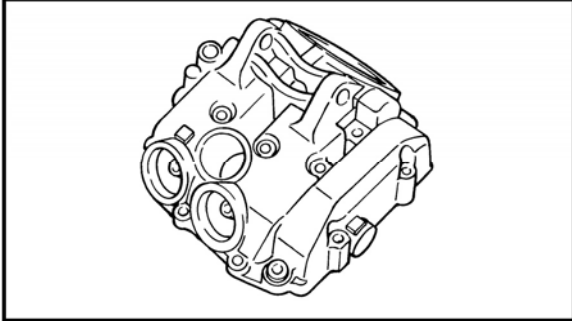

2). Checking the cylinder head cover

- cylinder head cover

Cracks/damage → Replace the cylinder head cover and cylinder head as a set.

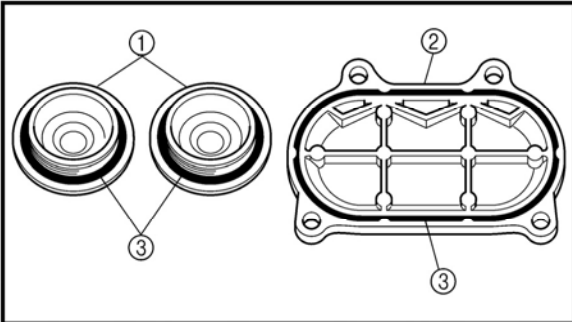

3). Checking the tappet covers

- tappet cover (exhaust) ①

- tappet cover (intake) ②

Cracks/damage → Replace.

- O-rings ③

NOTE:

When installing, new replacement washer and apply wheel bearing grease LS.

4). Removing the screwdriver and slowly release the timing chain tensioner rod.

NOTE:

Make sure that the timing chain tensioner rod comes out of the timing chain tensioner housing smoothly. If there is rough movement, replace the timing chain tensioner.

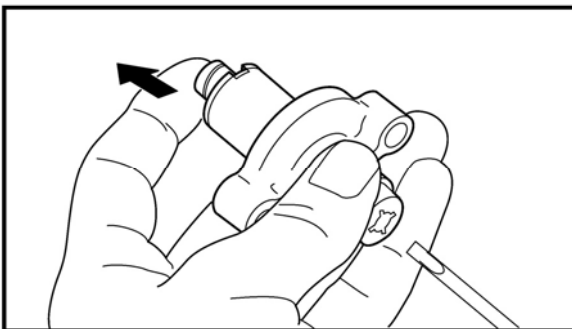

ENGINE

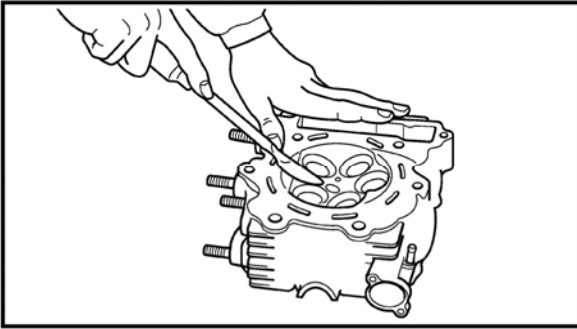

5). Checking the cylinder head

(1). Eliminate:

- carbon deposits (from the combustion chamber)

Use a rounded scraper.

NOTE:

Do not use a sharp instrument to avoid damaging or scratching:

- spark plug threads
- valve seats

(2). Check:

- cylinder head

Scratches/damage → Replace the cylinder head cover and cylinder head as a set.

- cylinder head water jacket

Mineral deposits/rust → Eliminate.

2. INSTALL

1). Installing the cylinder head cover

- cylinder head cover
- washers ①
- bolts ② (Allen wrench M5 , 8-12 Nm)

NOTE:

Tighten the cylinder head cover bolts in stages, using a crisscross pattern.

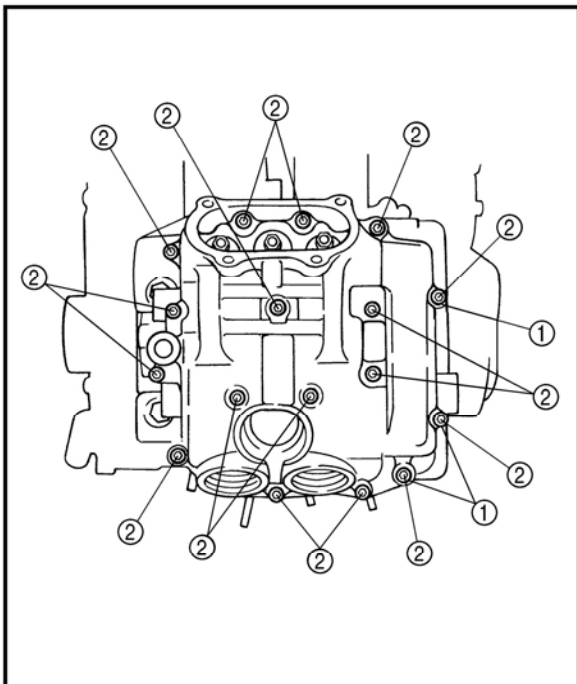

ENGINE

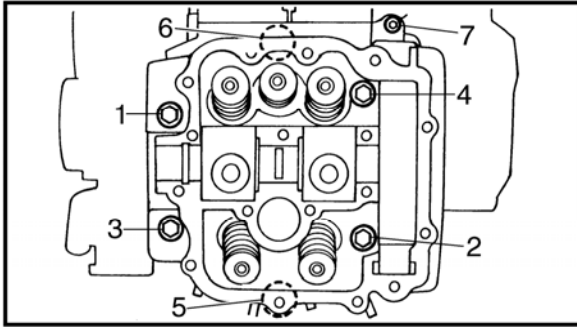

2). Installing the cylinder head

- cylinder head gasket
- cylinder head
- bolts (M9: 1 ~ 6, 38Nm)
- bolts (M6: 7, 10Nm)

NOTE:

- **Tighten the bolts in the proper sequence.**
- **Follow the numerical order shown in the illustration. Tighten the bolts in two stages.**

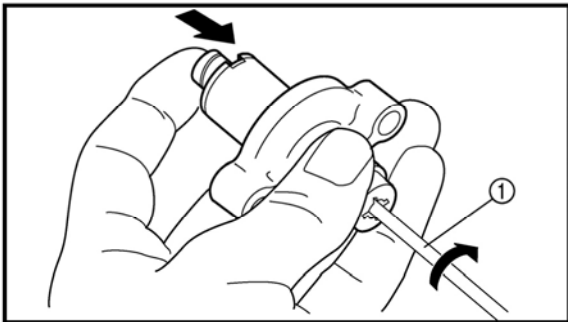

- timing chain guide (exhaust side)
 - timing chain tensioner
- a. Lightly press the timing chain tensioner rod into the timing chain tensioner housing by hand.
 - b. While pressing the timing chain tensioner rod, wind it clockwise with a thin screwdriver ① until it stops.
 - c. With the screwdriver still inserted into the timing chain tensioner, install the timing chain tensioner and gasket onto the cylinder block. Then, tighten the timing chain tensioner bolts to the specified torque.

WARNING:

Always use a new gasket.

NOTE:

The "UP" mark on the timing chain tensioner should face up.

Timing chain tensioner bolt (10 Nm)

- d. Remove the screwdriver, make sure that the timing chain tensioner rod releases, and tighten the cap bolt to the specified torque.

Timing chain tensioner cap bolt (7 Nm)

ENGINE

VALVE SWING ARM COMP&VALVE

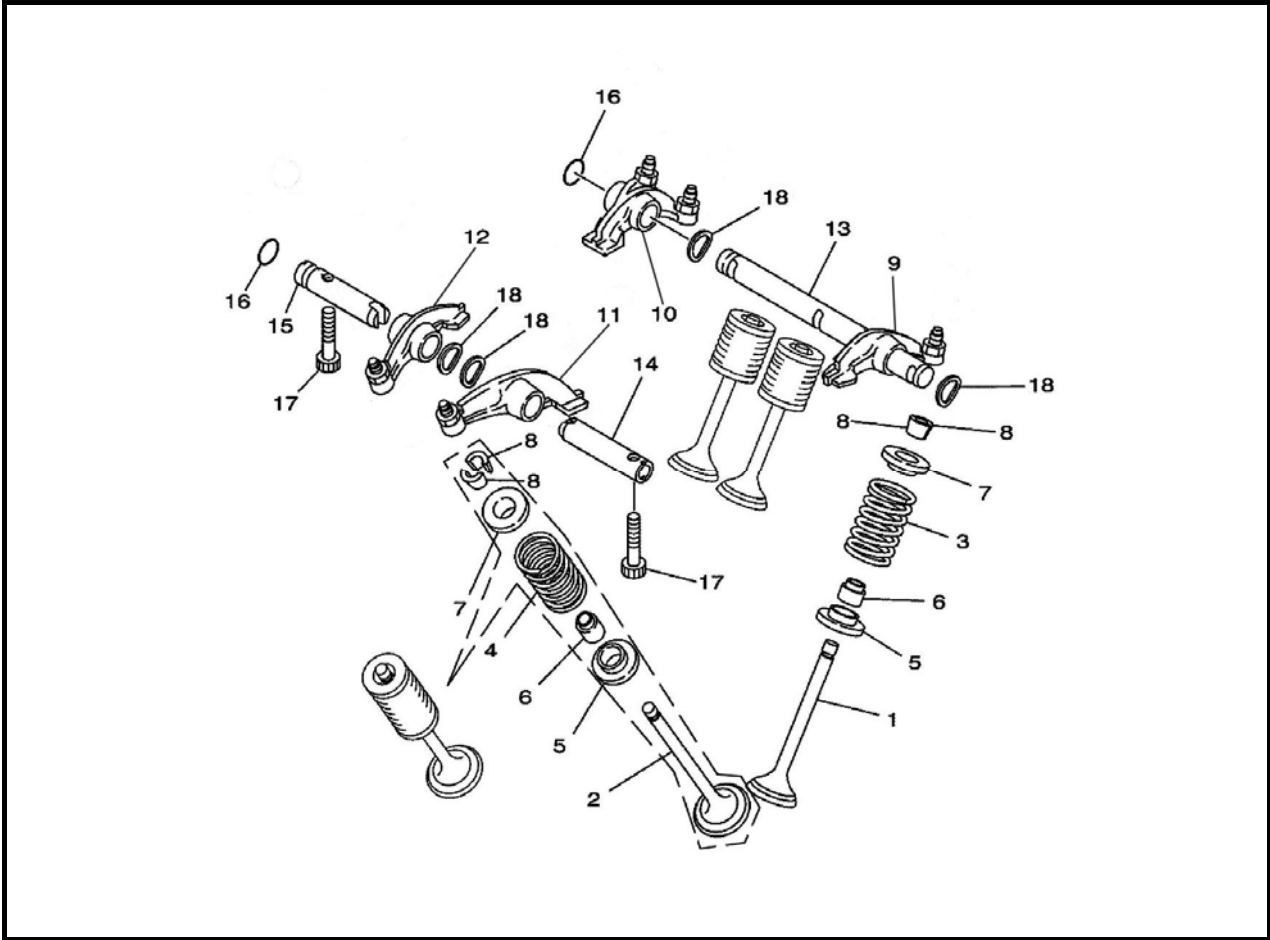

No.	Part Name	Qty	Remarks
	Removing the valve swing arm		Remove the parts in the order listed.
1	Inlet valve	3	
2	Outlet valve	2	
3	Spring inlet valve	3	
4	Spring outlet valve	2	
5	Spring seat valve	5	
6	Fuel shield cover comp	5	
7	Cotter seat- valve	5	
8	Lock clip valve	10	
9	Swing arm comp inlet valve I	1	
10	Swing arm comp inlet valve II	1	
11	Swing arm comp outlet valve II	1	
12	Swing arm comp outlet valve I	1	
13	Rocker arm shaft I	1	
14	Rocker arm shaft III	1	

ENGINE

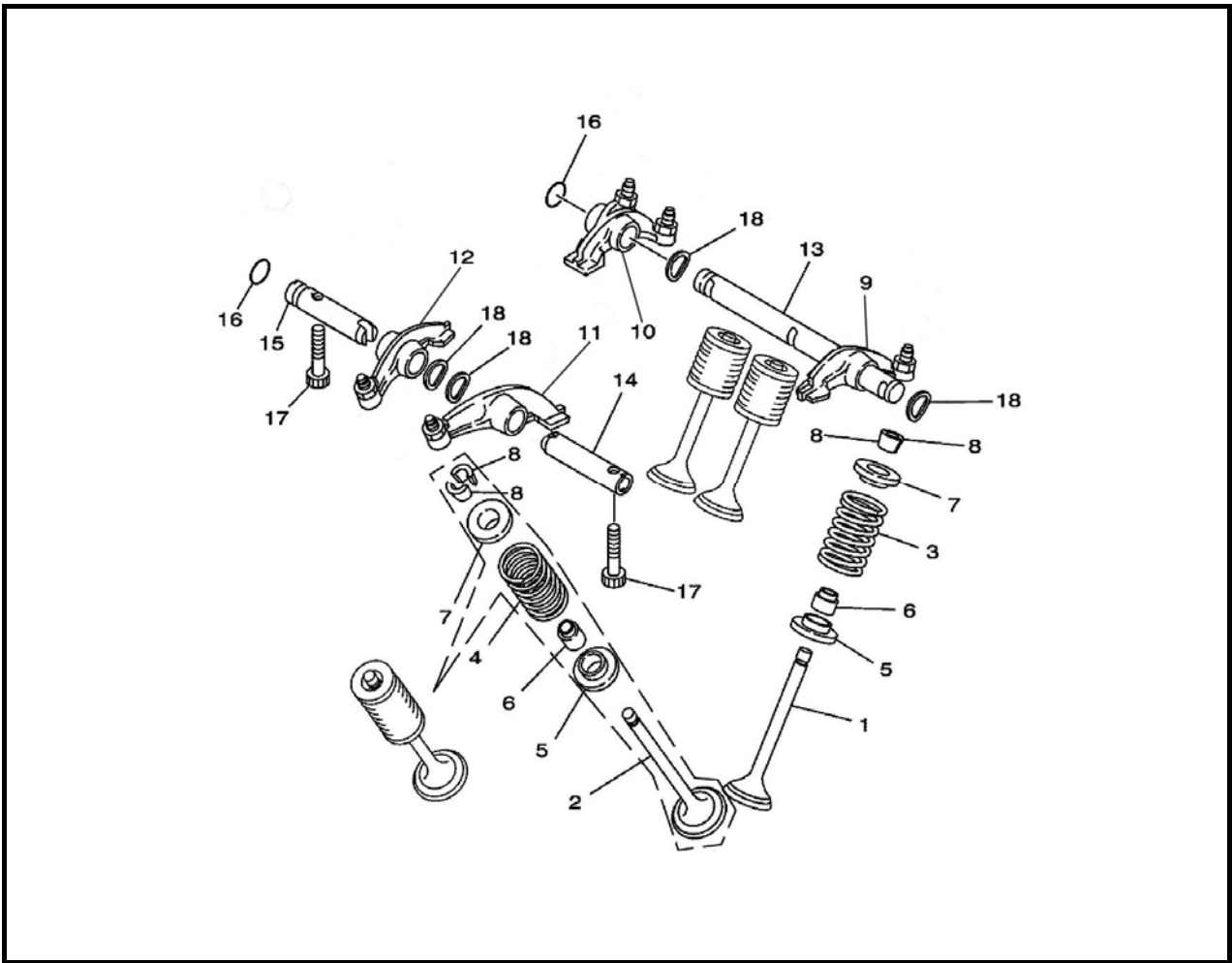

No.	Part Name	Qty	Remarks
15	Rocker arm shaft II	1	
16	O-ring 9×2	2	
17	Inner hexangular screw M6×20	2	
18	Washer φ 12.5× φ 34×0.4	4	
			For installation, reverse the removal procedure.

ENGINE

CAMSHAFT CHAIN

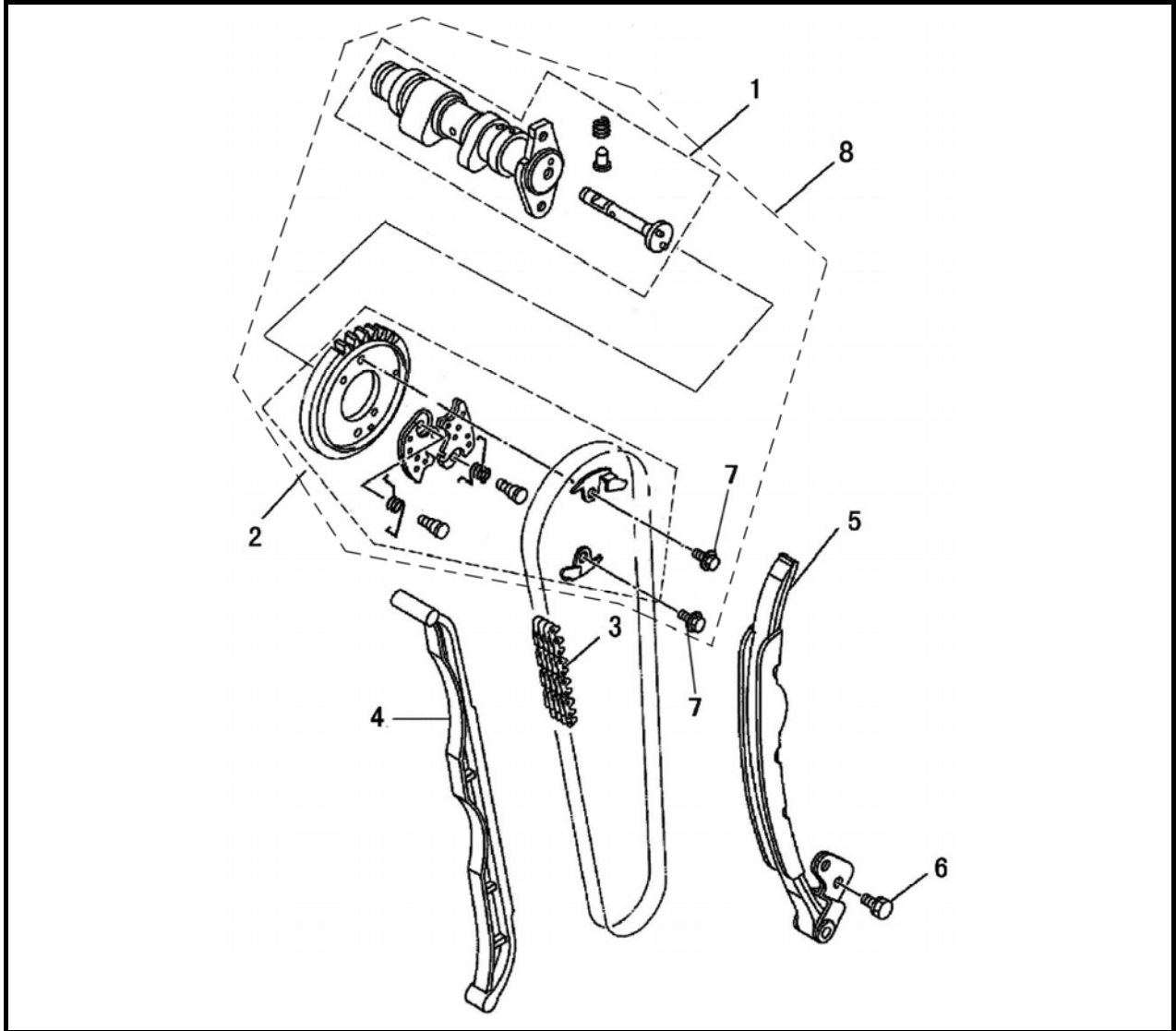

No.	Part Name	Qty	Remarks
1	Cam shaft comp	1	
2	Driven sprocket assy timing	1	
3	China (M7-6.35-126)	1	
4	Guide plate	1	
5	Tension plate comp	1	
6	Bolt M6×16	2	
7	Bolt M7×11	2	
8	Cam shaft assembly	1	
			For installation, reverse the removal procedure.

ENGINE

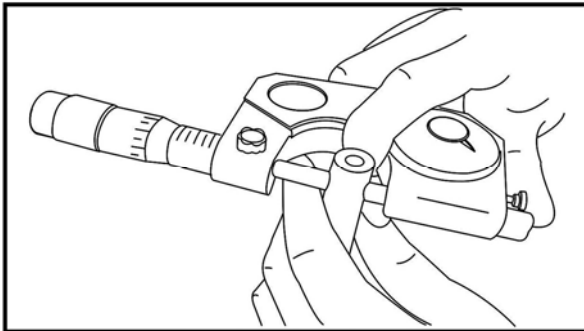
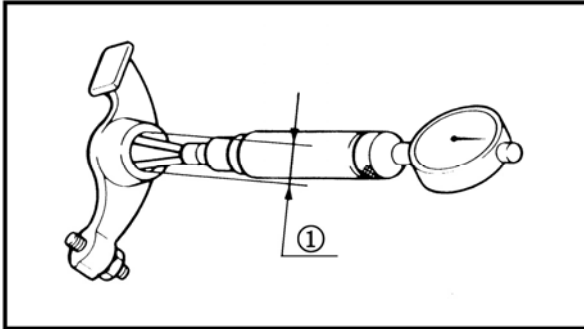
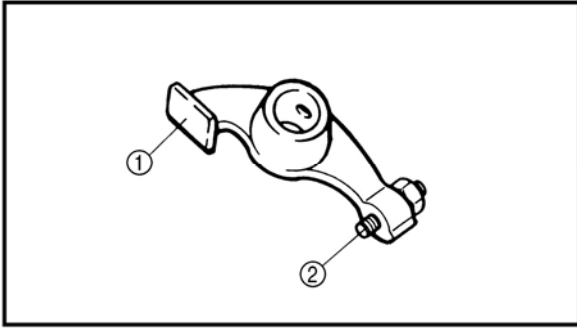

1、CHECK

1). Checking the rocker arms

- rocker arm lobes ①
- valve adjusters ②

Blue discoloration/pitting/scratches → Replace.

- rocker arms
- rocker arm shafts

Damage/wear → Replace.

a. Check whether the rocker arm is worn out, or damaged and whether the oil hole is blocked.

b. If there is a rocker arm to be replaced, check the camshaft prominent position of unfairness.

c. Measure the inside diameter of the rocker arm holes ①.

Out of specification → Replace.

Rocker arm inside diameter repairing limit value

Φ12.038mm

d. Check the surface of the rocker arm shafts.

Worn/pitting/scratches → Replace.

e. Measure the external diameter of rocker arm shaft with micrometer.

Out of specification → Replace.

Rocker arm shaft outside diameter repairing limit value

Φ11.96mm

f. Calculate the clearance by subtracting the rocker arm shaft outside diameter from the rocker arm inside diameter.

Out of specification → Replace the defective part(s).

Rocker arm to shaft clearance repairing limit value

0.05mm

ENGINE

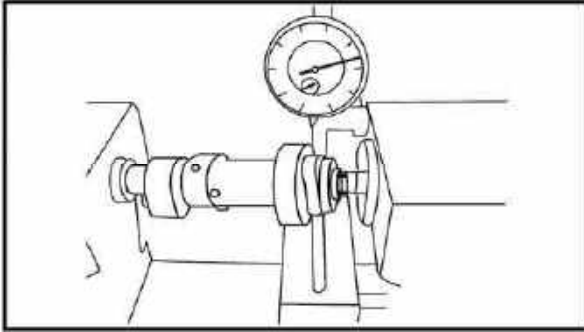

2). Checking the camshaft

- cam lobes
Pitting/scratches/blue discoloration → Replace
- camshaft journal
Wear/damage → Replace
- Measure the external diameter of camshaft journal with micrometer.
Out of specification → Replace.
- small holes on camshaft sprocket
- rotor "I" mark
Out of alignment

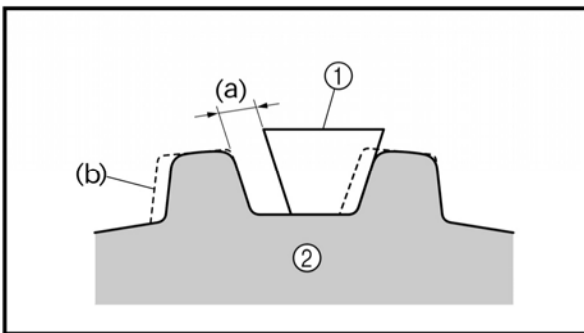

3). Checking the camshaft sprocket

- camshaft sprocket
Wear/damage → Replace the camshaft sprocket and timing chain as a set.

(a) 1/4 of a tooth

(b) Correct

- ① Timing chain
- ② Sprocket

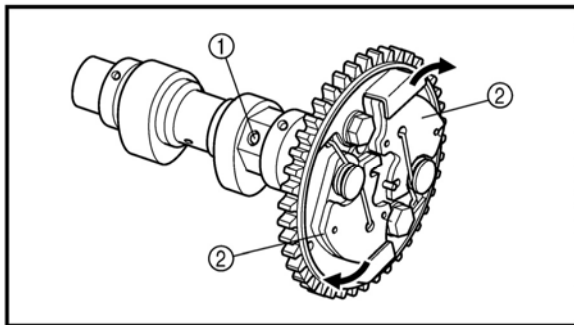

4). Checking the decompression system

- decompression system
Check while the camshaft sprocket is installed on the camshaft.
- a. Check that the decompressor lever pin ① projects from the camshaft.
- b. Check that the decompressor cam ② moves smoothly.

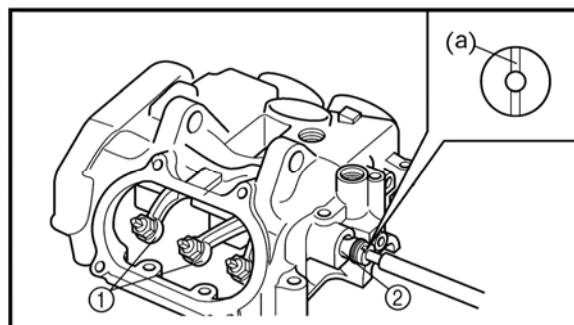

2. INSTALL

1). Installing the rocker arms

- rocker arms ①
- rocker arm shafts ②

NOTE:

- The thread hole (a) of the rocker arm shaft must face to the outside.
- After installation, make sure that the thread hole (a) of the rocker arm shaft is positioned correctly, as shown in the illustration.

ENGINE

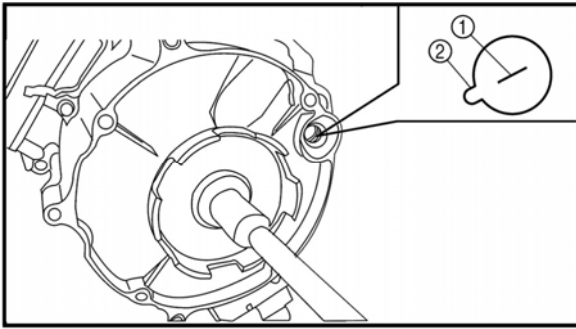

2). Installing the camshaft

- camshaft
 - camshaft sprocket
- Turn the crankshaft counterclockwise with a T-sleeve.
 - Align the "I" mark ① on the rotor with the stationary pointer ② on the A.C. magneto cover. When the "I" mark is aligned with the stationary pointer, the piston is at the Top Dead Center (TDC).

CAUTION:

Do not turn the crankshaft during the camshaft installation.

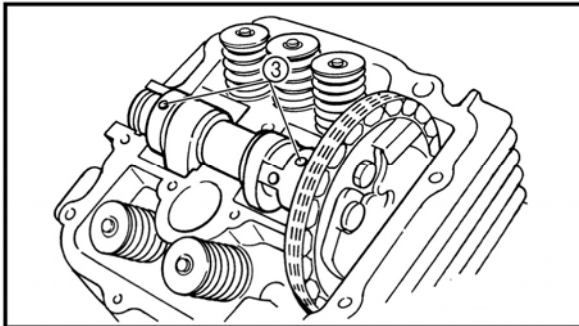

- Temporarily install the camshaft sprocket on the camshaft. (Do not install the bolts.) Then, install the timing chain on the camshaft sprocket.

NOTE:

Make sure the small holes ③ on the camshaft face upward.

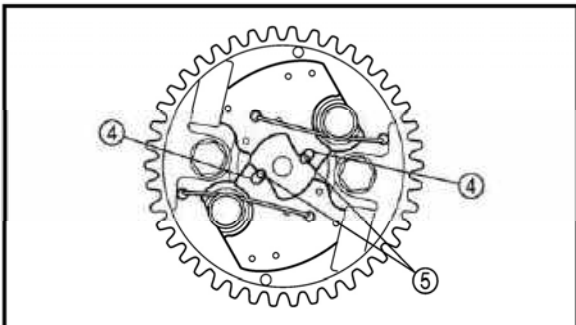

- Align the notches ④ on the decompressor cams with the projections ⑤ on the decompressor spring lever, then install the camshaft sprocket on the camshaft.

NOTE:

Check that each part is positioned as shown in the illustration.

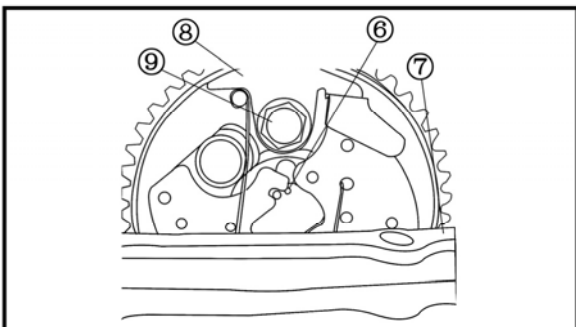

- ⑥ Punch mark on decompressor spring lever
 - ⑦ Top front of cylinder head
- Install the decompressor cam guide plates ⑧ and camshaft sprocket bolts ⑨

Camshaft sprocket bolt(20 Nm)

ENGINE

NOTE:

Insert a screwdriver into the timing chain tensioner hole and push the timing chain guide (intake side) inward.

f. Remove the retaining wire.

ENGINE

VALVES AND VALVE SPRINGS

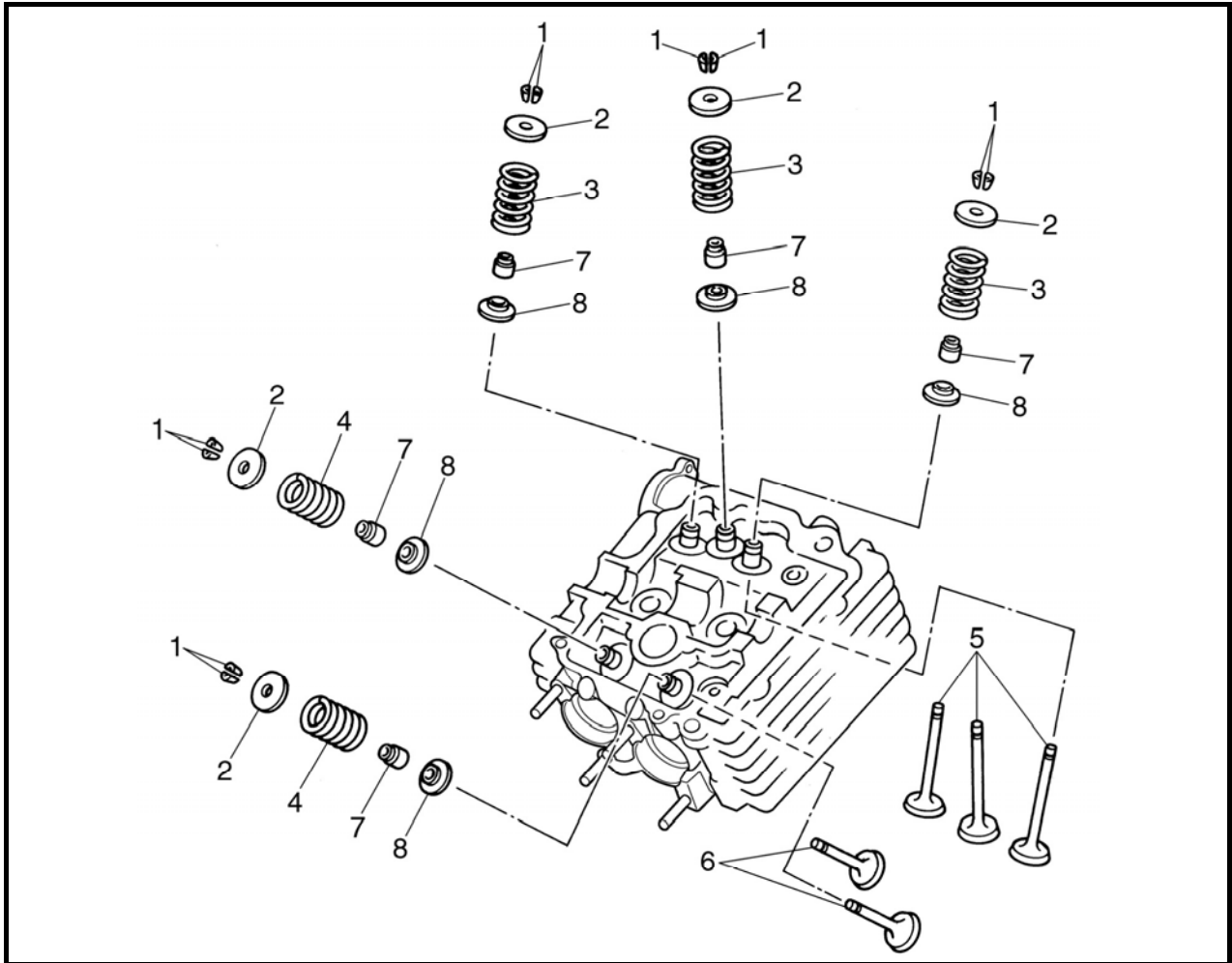

No.	Part Name	Qty	Remarks
	moving the valves and valve springs		Remove the parts in the order listed.
	Cylinder head cover		
1	Valve cotter	10	
2	Valve spring retainer	5	
3	Intake valve spring	3	
4	Exhaust valve spring	2	
5	Intake valve	3	
6	Exhaust valve	2	
7	Valve stem seal	5	
8	Valve spring seat	5	
			For installation, reverse the removal procedure.

ENGINE

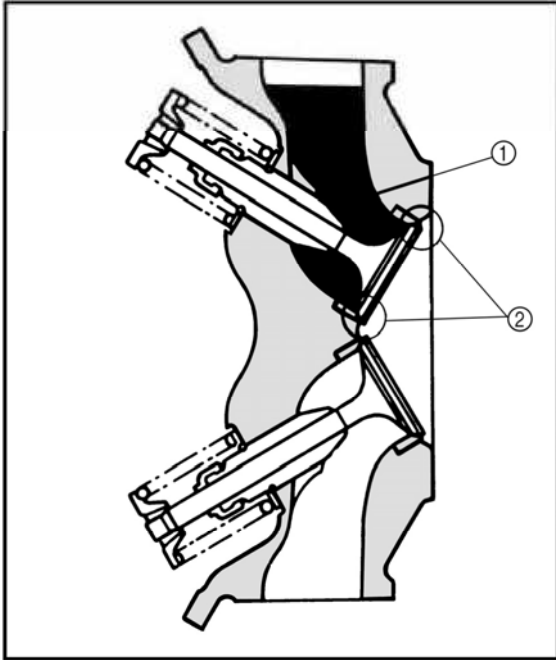

1、 CHECK

- valve sealing

Leakage at the valve seat → Check the valve face, valve seat and valve seat width.

- a. Pour a clean solvent ① into the intake and exhaust ports.
- b. Check that the valve seals properly. There should be no leakage at the valve seat ②.

- valve face

Pitting/wear → Grind the face.

- valve stem end

Mushroom shape or diameter larger than the body of the stem → Replace.

- valve seats

Pitting/wear → Reface the valve seat.

2、 MEASURE

1).Measure:

- The valves surface width

Repairing limit value

2.0mm

- stem-to-guide clearance

**Stem-to-guide clearance = valve guide
inside diameter – valve stem diameter**

1NOTE:

If the mating surface is coarse, corrode or cannot contact with valve seat normally, replace it.

Stem-to-guide clearance

repairing limit value

Intake:0.12mm Exhaust:0.14mm

- margin thickness (a)

Out of specification → Replace.

Margin thickness

Intake:0.85 ~ 1.15 mm

Exhaust:0.85 ~ 1.15 mm

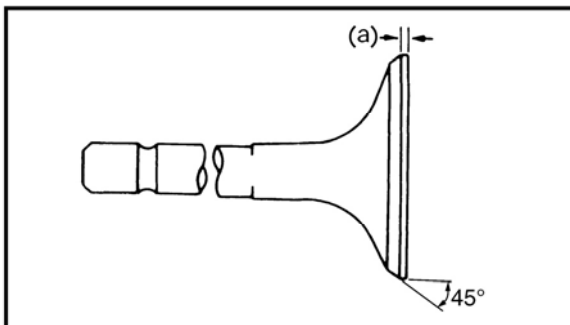

ENGINE

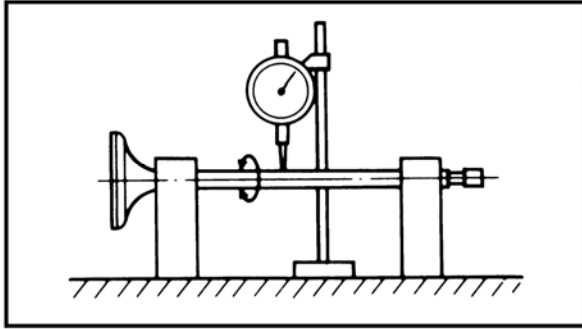

- valve stem runout
Out of specification → Replace.

Runout limit 0.01 mm

NOTE:

- When installing a new valve always replace the guide.
- If the valve is removed or replaced always replace the oil seal.

- The valve seat surface width
Out of specification → Reface the valve seat.

**Repairing limit value
2.0mm**

- Install the valve into the cylinder head.
- Press the valve through the valve guide and onto the valve seat to make a clear pattern.
- Measure the valve seat width. Where the valve seat and valve face made contact, blueing will have been removed.

- Valve spring free length
Out of specification → Replace.

Valve spring free length
Intake:32.5mm Exhaust:36.2mm
Valve spring squareness
Intake:0.10mm Exhaust:0.10mm

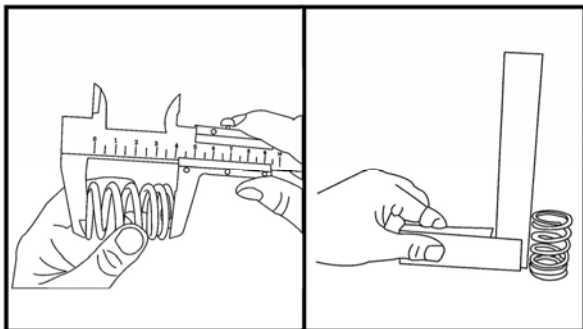

- compressed spring force(a)
Out of specification → Replace.

(b) Installed length

Compressed spring force
Intake: 100.0 ~ 115.7 N at 27.5 mm
Exhaust: 120.6 ~ 138.3 N at 31.0 mm

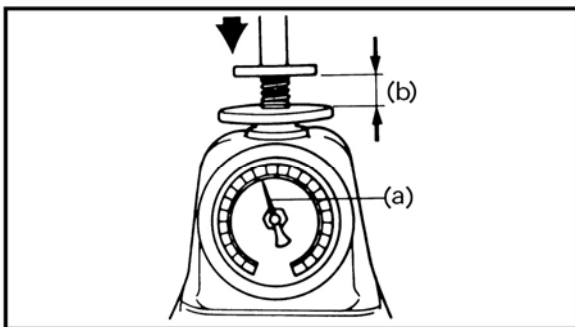

- Remove:
 - valve guide

ENGINE

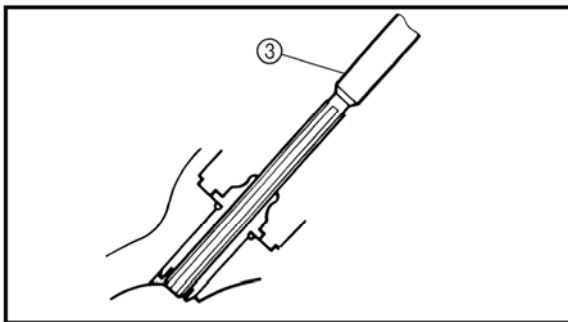
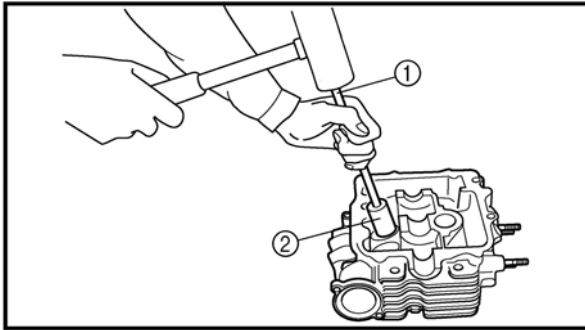

NOTE:

To ease guide removal, installation and to maintain correct fit, heat the cylinder head to 100 °C (212 °F) in an oven.

- Install the new valve guide using a valve guide remover ① and valve guide installer ②.
- After installing the valve guide, bore the valve guide using a valve guide reamer ③ to obtain proper stem-to-guide clearance.

NOTE:

After replacing the valve guide reface the valve seat.

- If the valve seat is too wide or narrow or cracked, grind it to ensure impermeability.

3). Lap:

- valve face
- valve seat

NOTE:

After refacing the valve seat or replacing the valve and valve guide, the valve seat and valve face should be lapped.

- If the pipe will be replaced, grind the valve seat again.

CAUTION:

Do not let the compound enter the gap between the valve stem and the guide.

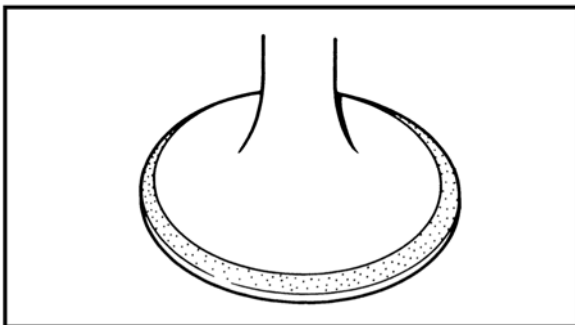

- Install the valve into the cylinder head.
- Turn the valve until the valve face and valve seat are evenly polished, then clean off all of the compound.

ENGINE

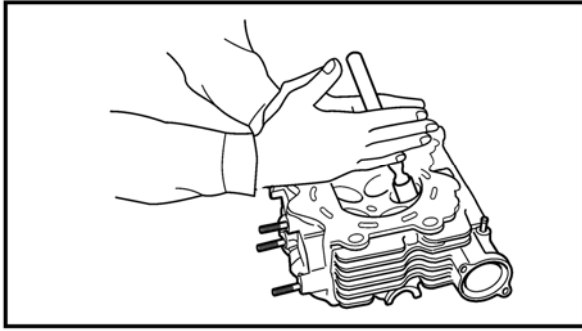

NOTE:

For best lapping results, lightly tap the valve seat while rotating the valve back and forth between your hands.

d. Apply a fine lapping compound to the valve face and repeat the above steps.

NOTE:

After every lapping operation be sure to clean off all of the compound from the valve face and valve seat.

e. Install the valve into the cylinder head.

g. Press the valve through the valve guide and onto the valve seat to make a clear pattern.

h. Measure the valve seat width again. If the valve seat width is out of specification, reface and relapse the valve seat.

3. INSTALL:

1). Apply:

- molybdenum disulfide oil
(onto the valve stem and valve stem seal)

2). Install:

- valve spring seats
- valve stem seals
- valves
- valve springs
- valve spring retainers

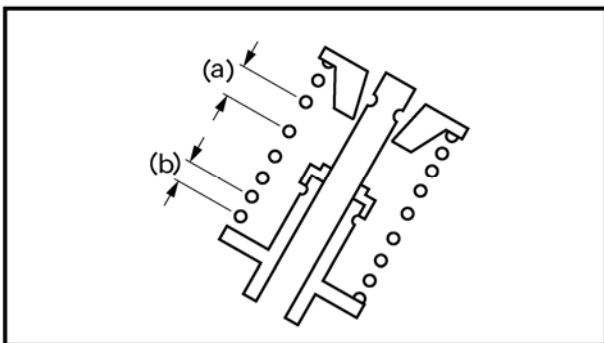

NOTE:

Install the valve springs with the larger pitch (a) facing upwards.

(b) Smaller pitch

- valve cotters

NOTE:

Install the valve cotters while compressing the valve spring with the valve spring compressor ① and valve spring compressor attachment ②.

ENGINE

CYLINDER AND PISTON

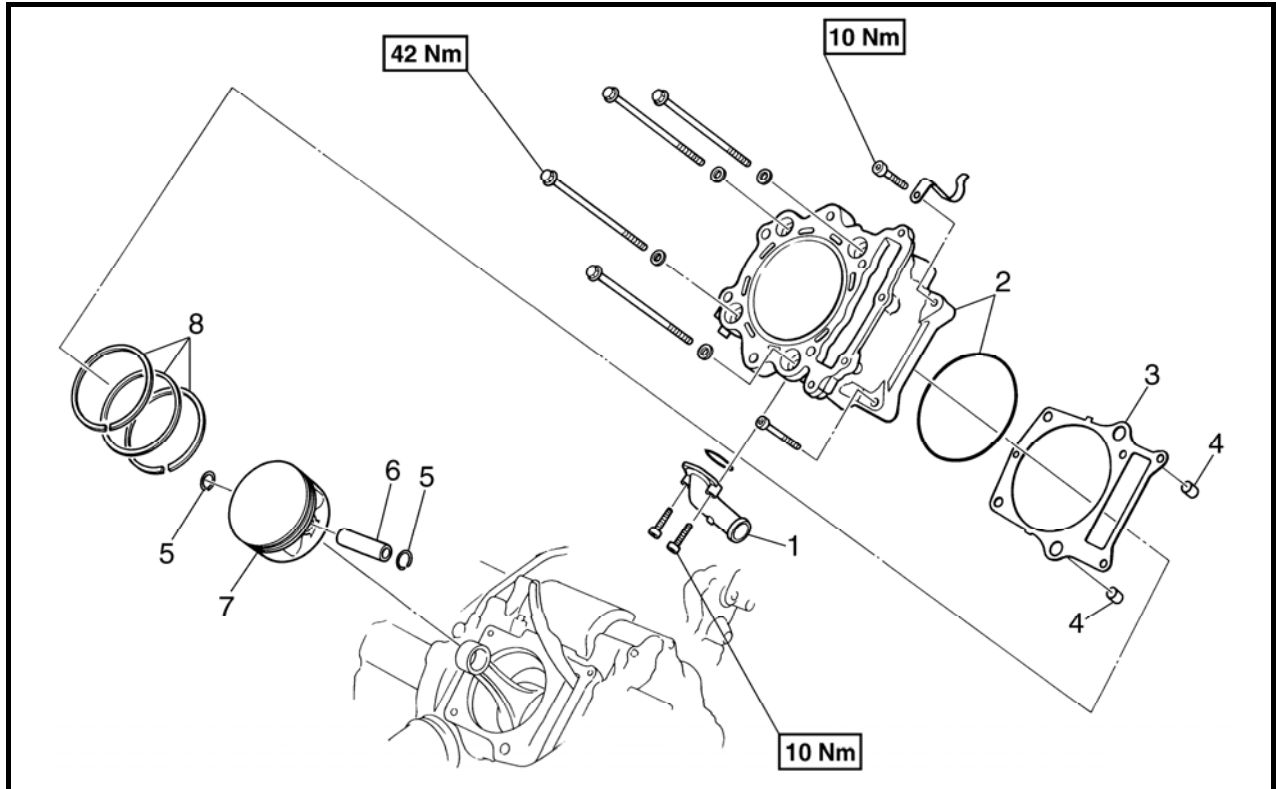

No.	Part Name	Qty	Remarks
	Removing the cylinder and piston		Remove the parts in the order listed.
	Water pump outlet hose		
	Cylinder head		
1	Coolant inlet joint	1	
2	Cylinder/O-ring	1/1	
3	Cylinder gasket	1	
4	Dowel pin	2	
5	Piston pin clip	2	
6	Piston pin	1	
7	Piston	1	
8	Piston ring set	1	
			For installation, reverse the removal procedure.

ENGINE

1. CHECK

1).Checking the cylinder and piston

- cylinder and piston walls Vertical scratches → Rebore or replace the cylinder and the piston.

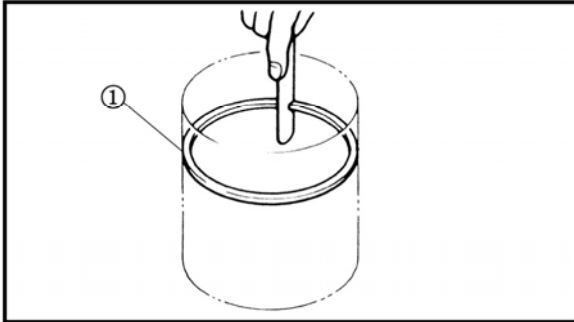

2).Checking the piston rings

- piston ring
(Insert in cylinder piston ring will be ① ,and measure the end gap.)

NOTE:

Check whether the piston and the piston groove is cracked and abraded.

3).Checking the piston pin

- piston pin
Blue discoloration/grooves → Replace, then check the lubrication system.

2. MEASURE

- At the top, the middle and the bottom of the piston stroke.

NOTE:

Measure the bore diameter at directions of right-angle intersection.

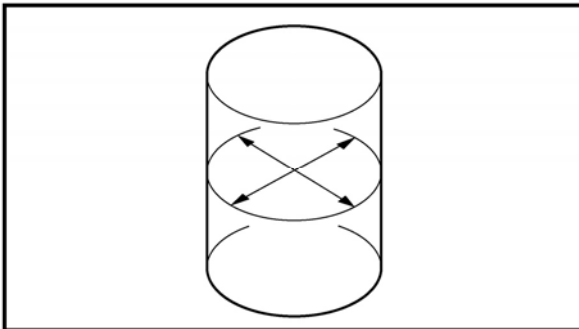

Repairing limit value

Out of roundness:0.005mm

Taper:0.005mm

- The external diameter 10mm above the bottom of the piston skirt.

NOTE:

Repair limit on the clearance between the piston and cylinder.

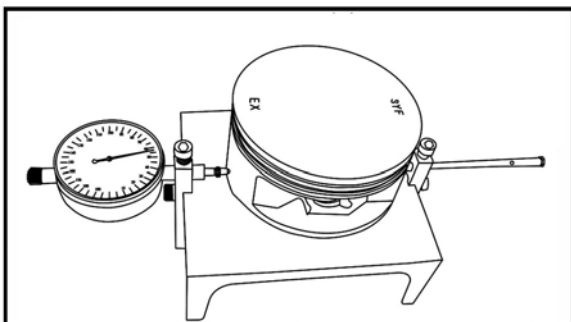

Repairing limit value

0.1mm

ENGINE

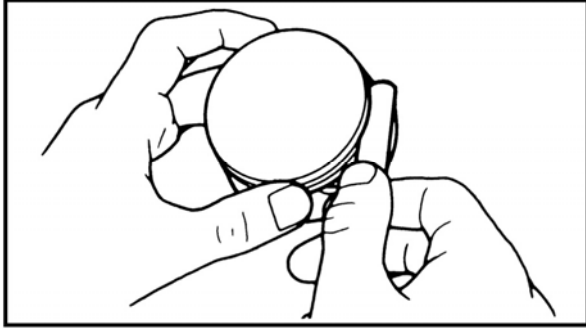

- ring end gap

Out of specification → Replace.

Repairing limit value

Top ring/2nd ring:0.5mm

- ring side clearance

Use a thickness gauge.

Out of specification → Replace the piston and rings as a set.

NOTE:

Clean carbon from the piston ring grooves and rings before measuring the side clearance.

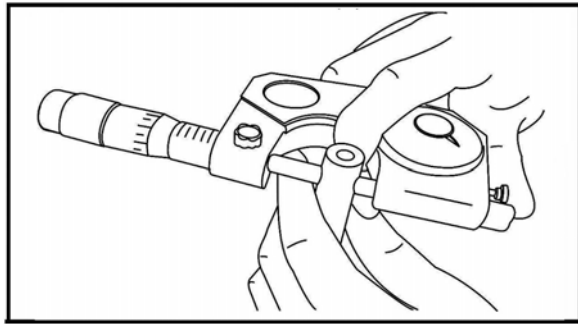

	Side clearance	
	Standard	Limit
Top ring	0.04~0.08mm	0.13mm
2nd ring	0.03~0.07mm	0.13mm

- piston pin-to-piston clearance.

a. Measure the piston pin outside diameter.

Repairing limit value

0.02mm

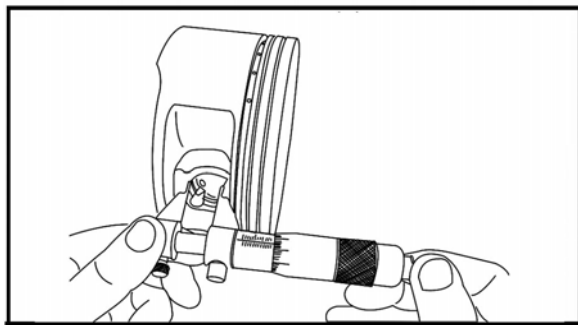

b. Measure the piston pin bore inside diameter.

Repairing limit value

0.02mm

c. Calculate the piston pin-to-piston clearance with the following formula.

Piston pin-to-piston clearance = Piston pin bore inside diameter – Piston pin outside diameter

d. If out of specification, replace the piston.

ENGINE

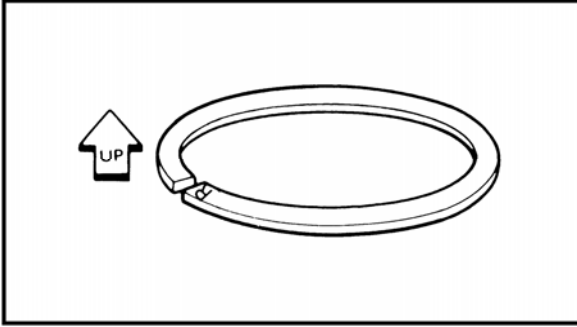

3. INSTALL:

1). Installing the piston

- piston rings
(onto the piston)

NOTE:

- Be sure to install the piston rings so that the manufacturer's marks or numbers are located on the upper side of the rings.
- Lubricate the piston and piston rings liberally with engine oil.

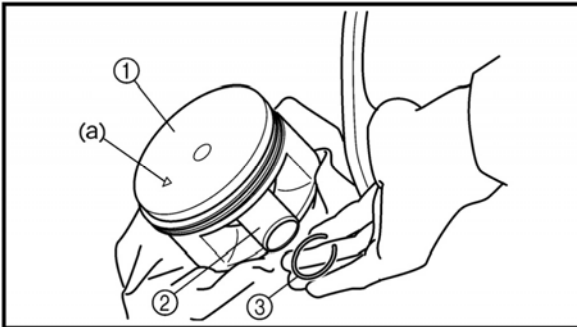

- piston ①
- piston pin ②
- piston pin clips ③ (new replacement)

NOTE:

- Apply engine oil onto the piston pin, piston rings and piston.
- Be sure that the arrow mark a on the piston points to the exhaust side of the engine.
- Before installing the piston pin clip, cover the crankcase with a clean rag to prevent the piston pin clip from falling into the crankcase.

2). Installing the cylinder

- cylinder
- O-ring
- bolts (M10,42Nm)
- bolts (M6,10Nm)

NOTE:

Install the cylinder with one hand while compressing the piston rings with the other hand.

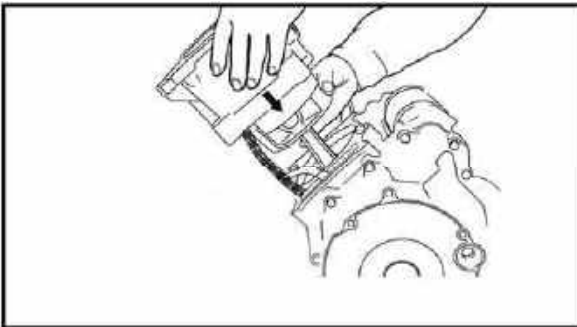

CAUTION:

- Be careful not to damage the timing chain guide during installation.
- Pass the timing chain through the timing chain cavity.

ENGINE

ENGINE COOLING FAN AND A.C. MAGNETO

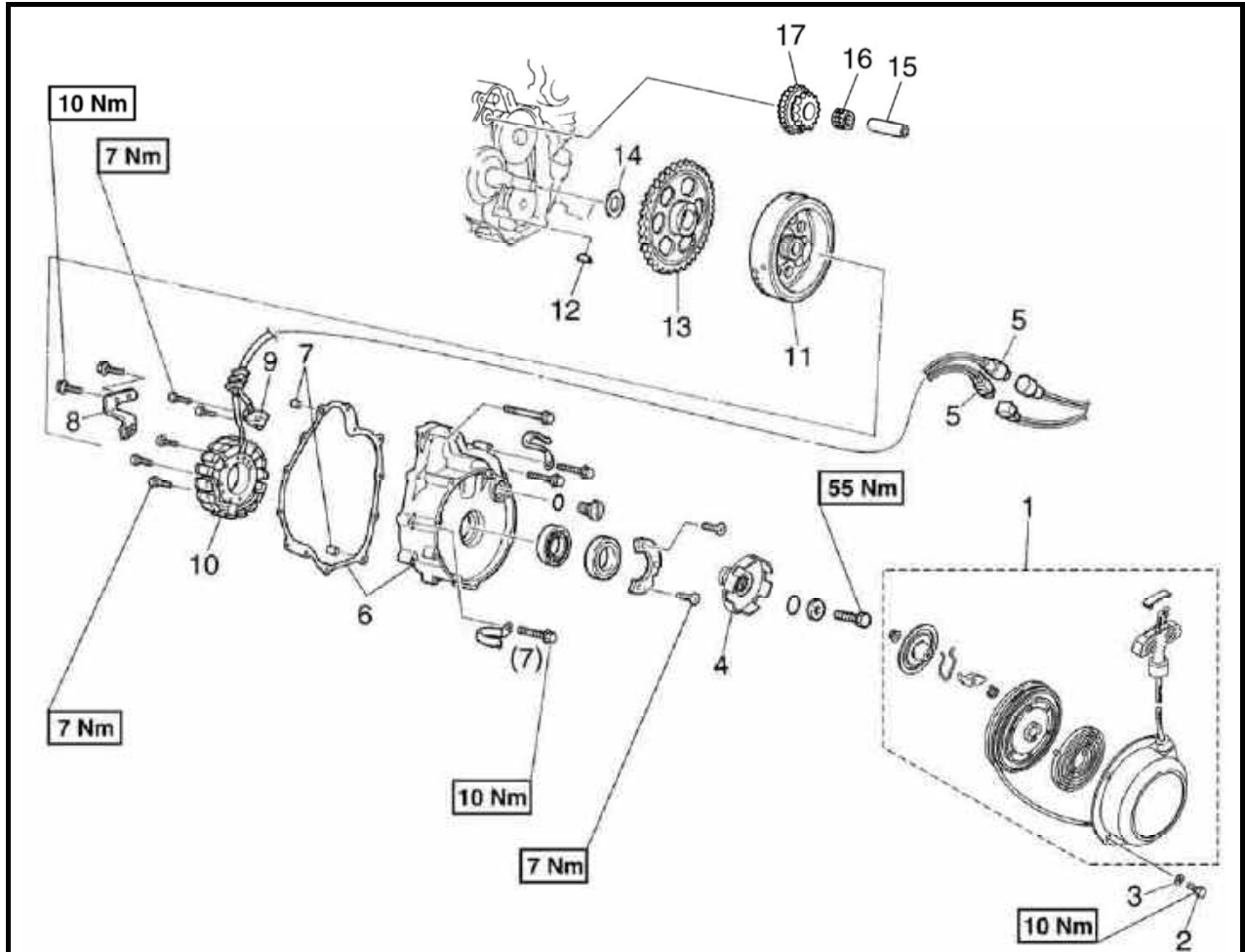

No.	Part Name	Qty	Remarks
	Removing the engine cooling fan and A.C. magneto		Remove the parts in the order listed.
	Drive belt cover		
	Engine oil		
	Coolant		
1	Hand starter the component	1	
2	Bolt	4	
3	Washer	4	
4	Starter driven gear parts	1	
5	A.C. magneto coupler	2	
6	A.C. magneto cover/gasket	1/1	
7	Dowel pin	2	
8	Stator lead holder	1	
9	Pickup coil	1	

ENGINE

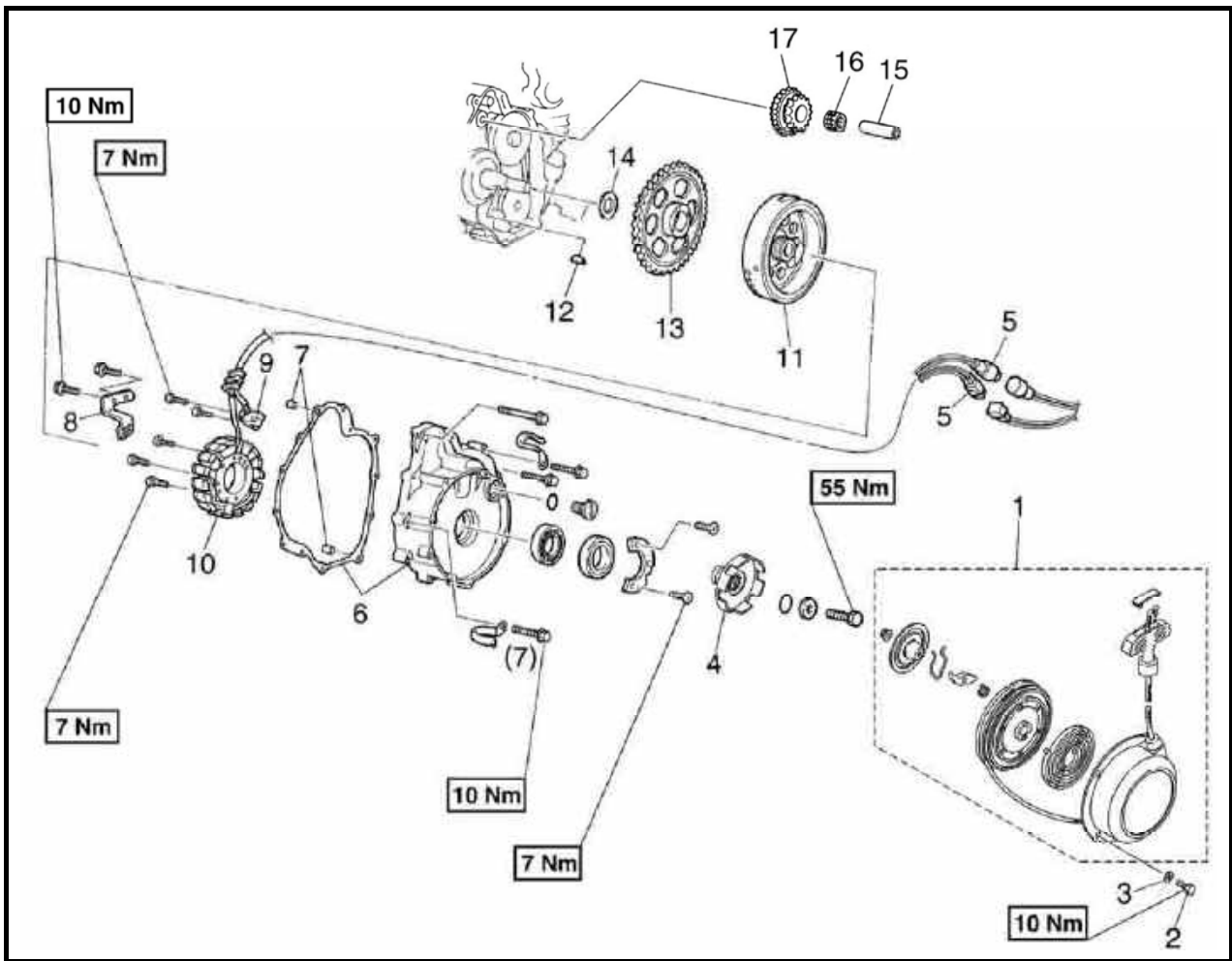

No.	Part Name	Qty	Remarks
10	Stator assembly	1	For installation, reverse the removal procedure.
11	A.C. magneto rotor	1	
12	Woodruff key	1	
13	Starter wheel gear	1	
14	Washer	1	
15	Starter idle gear shaft	1	
16	Bearing	1	
17	Starter idle gear	1	

ENGINE

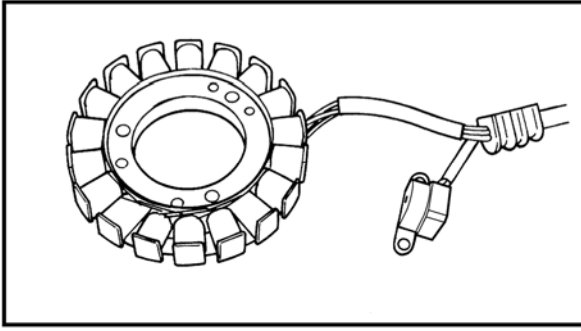

1. CHECK

1). Checking the A.C. magneto

- stator coil
- pickup coil

Damage → Replace.

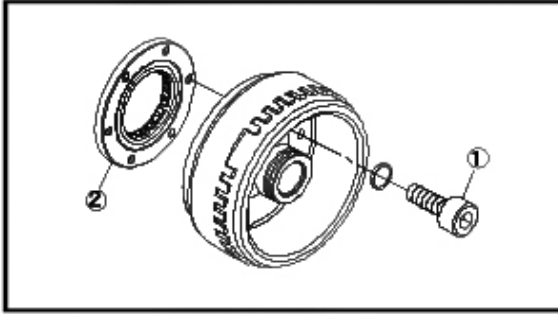

2). Checking the starter clutch

- starter clutch ①
Cracks/damage → Replace.
- starter clutch bolts ②
Loose → Replace with new ones, and clinch the end of the bolts.

NOTE:

- The arrow mark on the starter clutch must face inward, away from the A.C. magneto rotor.
- When installing, apply the locking agent.

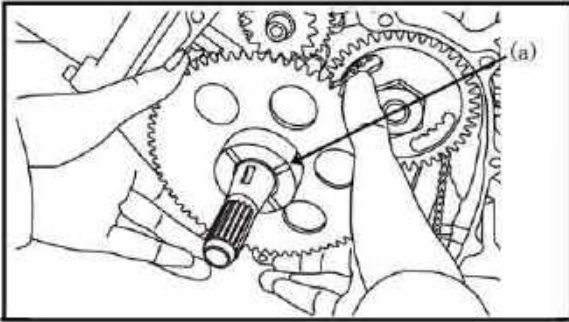

- a. Install the starter wheel gear onto the starter clutch, and hold the starter clutch.

NOTE:

- Install the starter wheel gear with the groove (a) facing the A.C. magneto rotor.

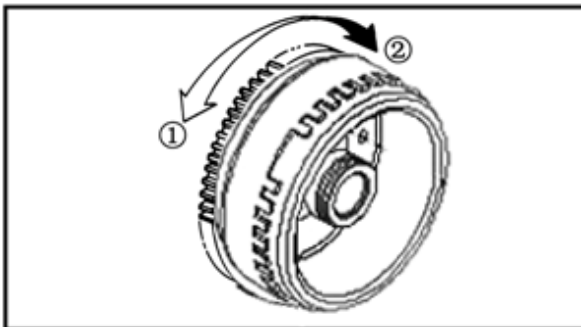

- b. Turn the starter wheel gear counterclockwise ① to check that the starter clutch and wheel gear engage.

If the starter clutch and wheel gear do not engage, replace the starter clutch.

- c. Turn the starter wheel gear clockwise ② to check the starter wheel gear for smooth operation.

If operation is not smooth, replace the starter clutch.

ENGINE

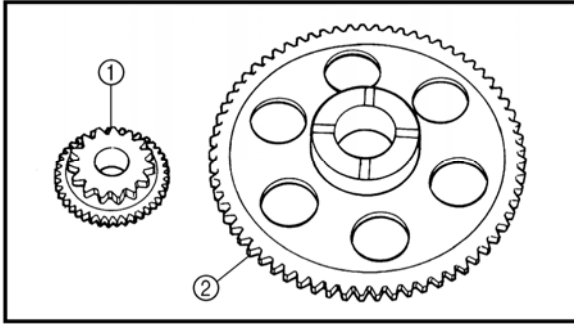

- starter idle gear teeth ①
 - starter wheel gear teeth ②
- Burrs/clips/roughness/wear → Replace.
- starter wheel gear
(contacting surface)
Damage/pitting/wear → Replace.

2. INSTALL

- woodruff key
- A.C. magneto rotor

NOTE:

- Before installing the rotor, clean the outside of the crankshaft and the inside of the rotor.
- After installing the rotor, check that the rotor rotates smoothly. If not, reinstall the key and rotor.

- dowel pins
- gasket (New replacement)
- A.C. magneto cover(10Nm)

NOTE:

- When installing the A.C. magneto cover, use a long rod to hold the A.C. magneto rotor in position from the outside. This will make assembly easier. Be careful not to damage the oil seal.
- Apply sealant (Quick Gasket) ① to the thread of the bolt ② shown in the illustration.
- Tighten the bolts in stages, using a crisscross pattern.

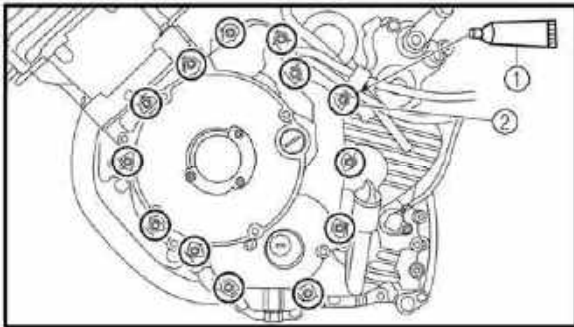

ENGINE

BALANCER GEARS AND OIL PUMP GEARS

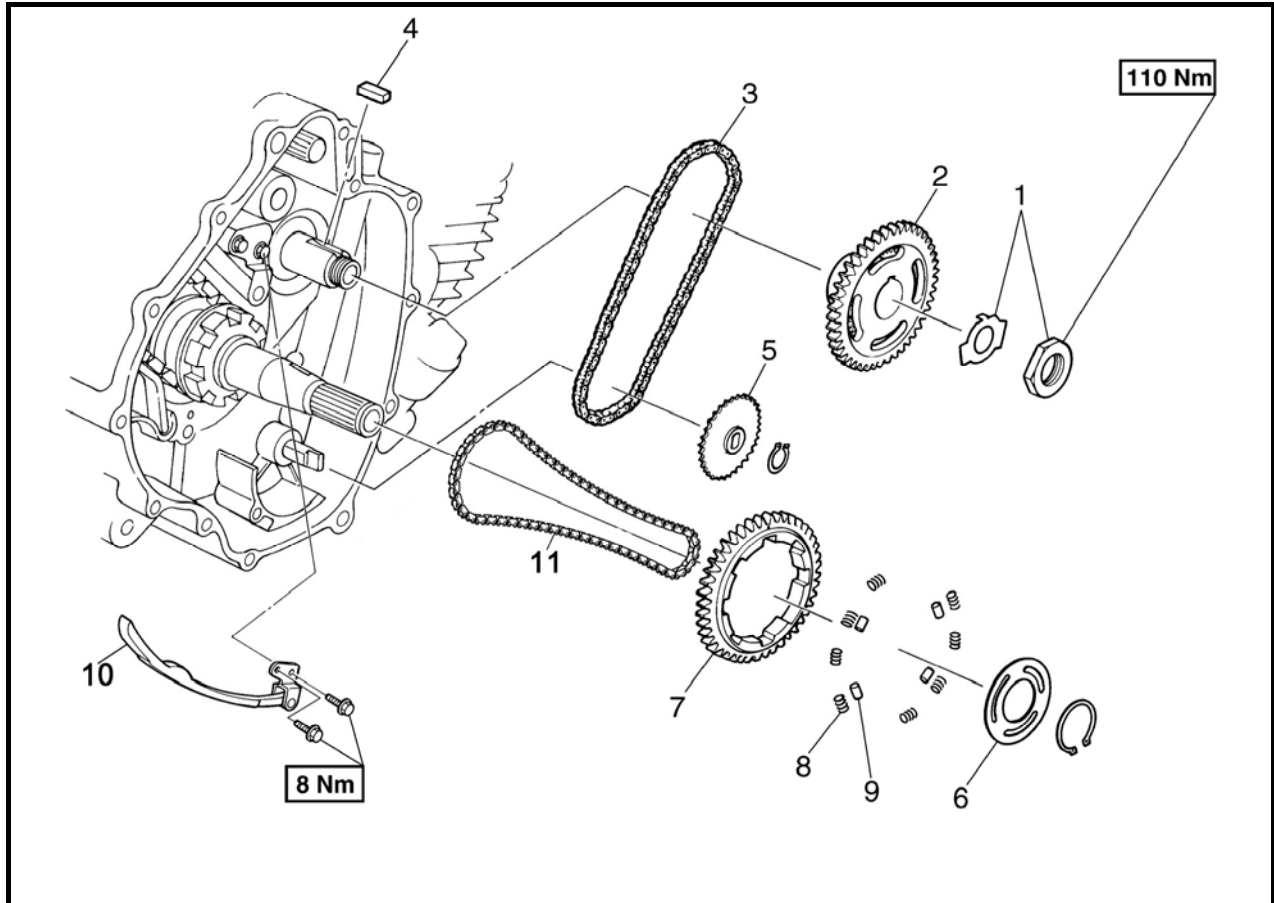

No.	Part Name	Qty	Remarks
	Removing the balancer gears and oil pump gears		Remove the parts in the order listed.
1	Nut/lock washer	1/1	
2	Balancer driven/oil pump drive gear	1	
3	Chain	1	
4	Straight key	1	
5	Oil pump driven gear	1	
6	Plate	1	
7	Balancer drive gear	1	
8	Spring	8	
9	Pin	4	
10	Timing chain guide (intake side)	1	
11	Timing chain	1	
			For installation, reverse the removal procedure.

ENGINE

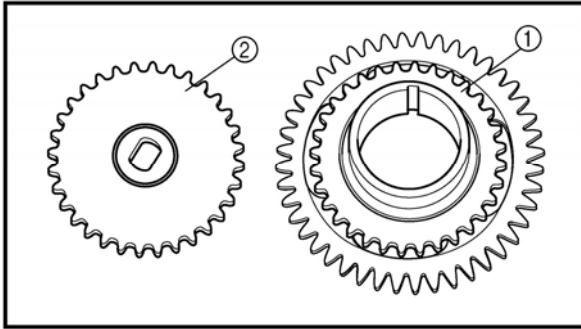

1、CHECK

- 1) Checking the oil pump drive gear and oil pump driven gear
- oil pump drive gear ①
 - oil pump driven gear ②
- Cracks/wear/damage → Replace

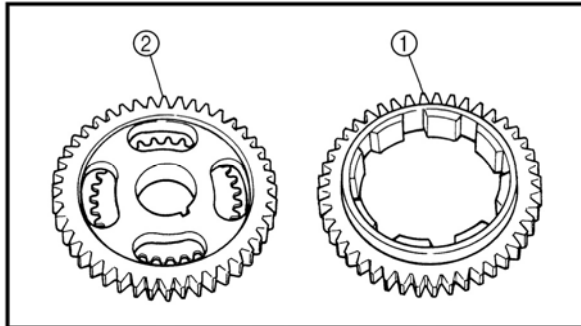

- 2).Checking the balancer drive gear and balancer driven gear

- balancer drive gear ①
- balancer driven gear ②

Damage/wear → Replace the balancer drive gear and balancer driven gear as a set.

Excessive noise during operation → Replace the balancer drive gear and balancer driven gear as a set.

- 3). Checking the timing chain and guides

- timing chain

Cracks/stiff → Replace the timing chain and camshaft sprocket as a set.

- timing chain guides

Wear/damage → Replace.

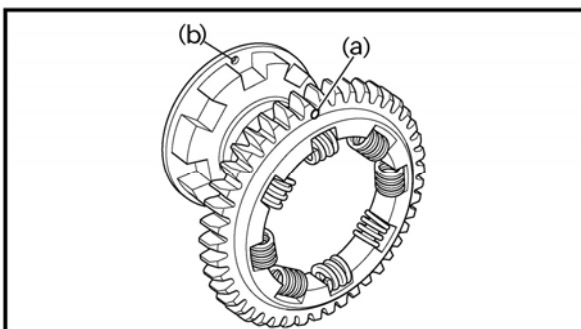
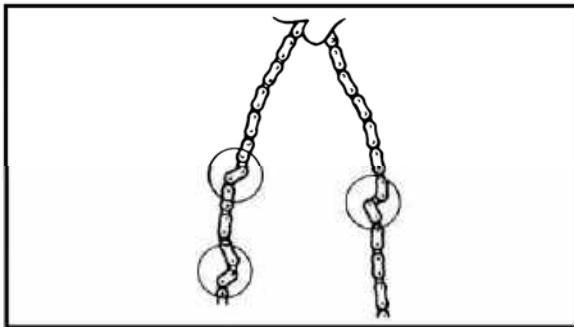

2、INSTALL

- pins
- springs
- balancer drive gear (onto the buffer boss)
- plate
- circlip

NOTE:

Align the punch mark (a) on the balancer drive gear with the hole (b) to the buffer boss.

ENGINE

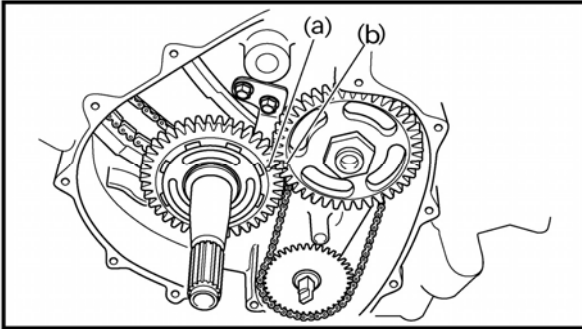

- balancer driven gear

NOTE:

Align the punch mark (a) on the balancer drive gear with the punch mark (b) on the balancer driven gear.

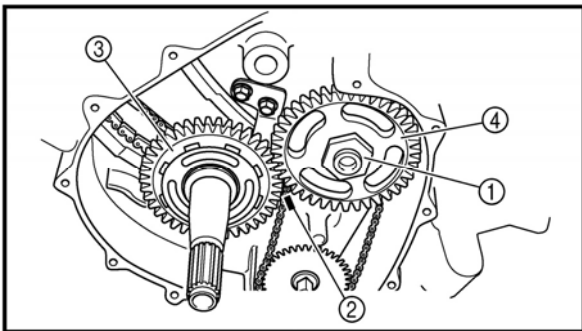

- lock washer(new replacement)
- balancer driven gear nut ①(110Nm)

NOTE:

- Place an aluminum plate ② between the teeth of the balancer drive gear ③ and balancer driven gear ④.
 - Apply the molybdenum disulfide grease to the thread of axle and nut.
-

ENGINE

PRIMARY AND SECONDARY SHEAVES

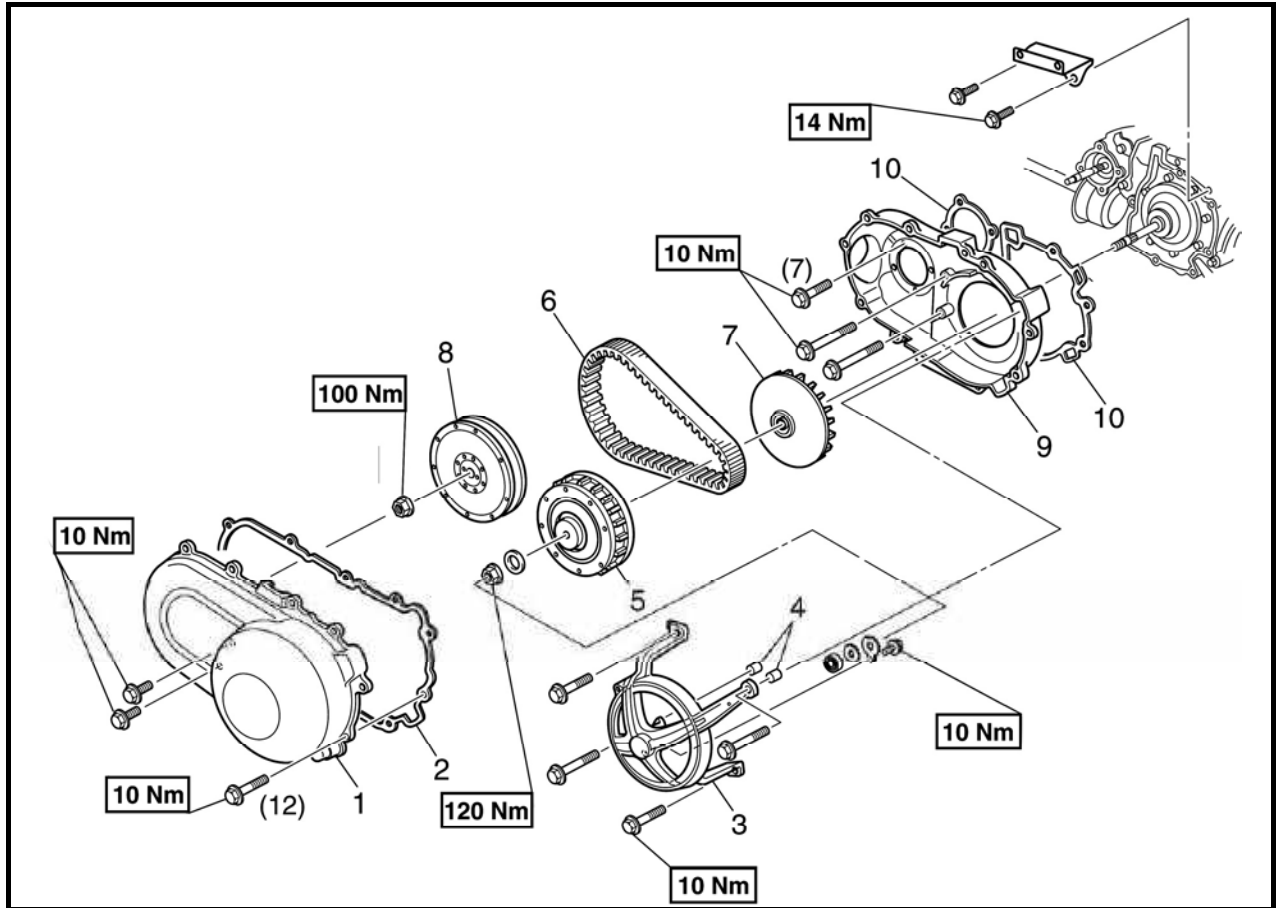

No.	Part Name	Qty	Remarks
	Removing the primary and secondary sheaves		Remove the parts in the order listed.
	Engine assembly		
1	Drive belt cover	1	
2	Rubber gasket	1	
3	Bearing housing	1	
4	Dowel pin	2	
5	Primary sheave assembly	1	
6	V-belt	1	
7	Primary fixed sheave	1	
8	Secondary sheave assembly	1	
9	Drive belt case	1	
10	Rubber gasket	2	
			For installation, reverse the removal procedure.

ENGINE

PRIMARY SHEAVE

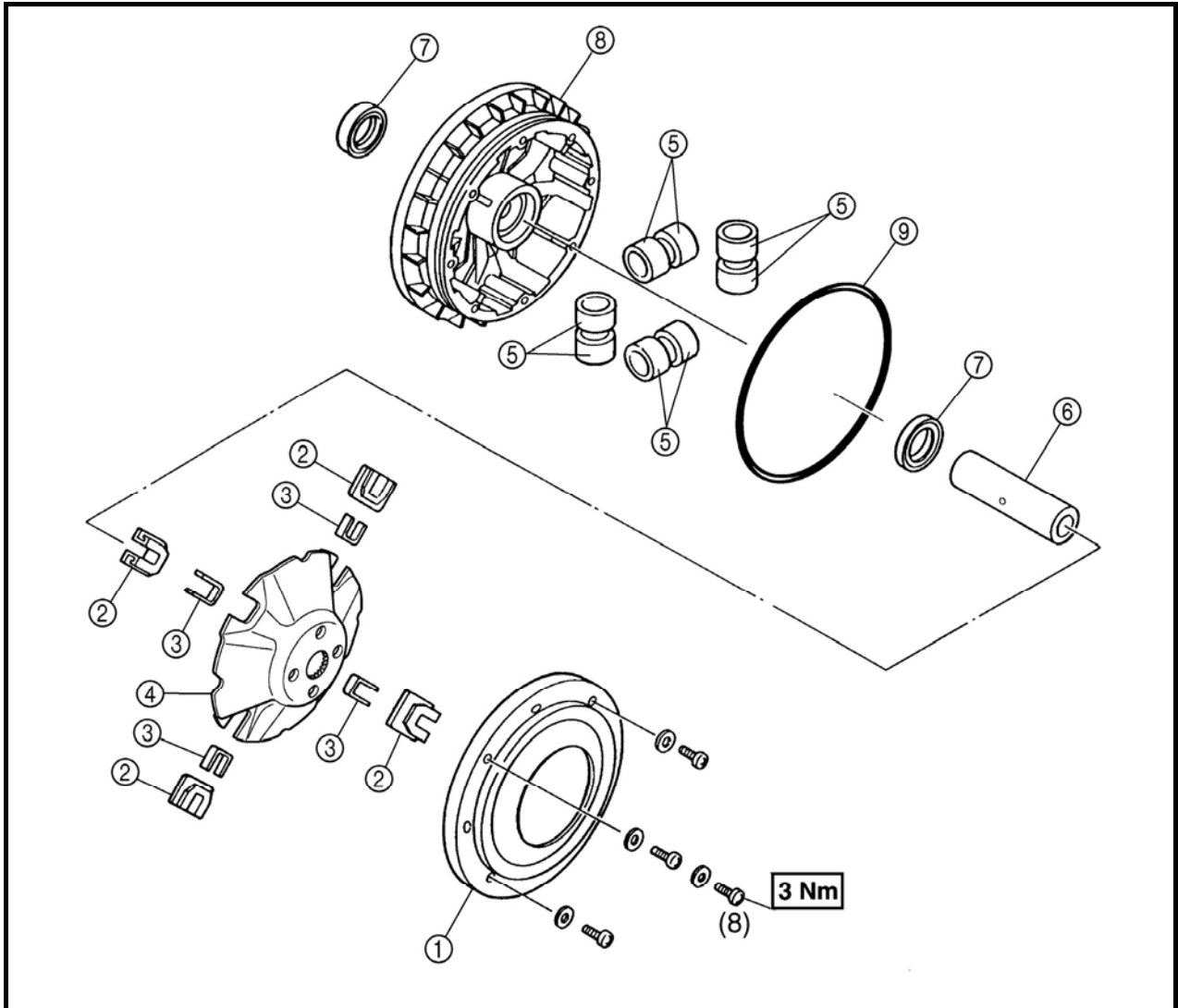

No.	Part Name	Qty	Remarks
	Disassembling the primary sheave		Remove the parts in the order listed.
1	Primary pulley sheave cap	1	
2	Primary pulley slider	4	
3	Spacer	4	
4	Primary pulley cam	1	
5	Primary pulley weight	8	
6	Collar	1	
7	Oil seal	2	
8	Primary sliding sheave	1	
9	O-ring	1	
			For assembly, reverse the disassembly procedure.

ENGINE

SECONDARY SHEAVE

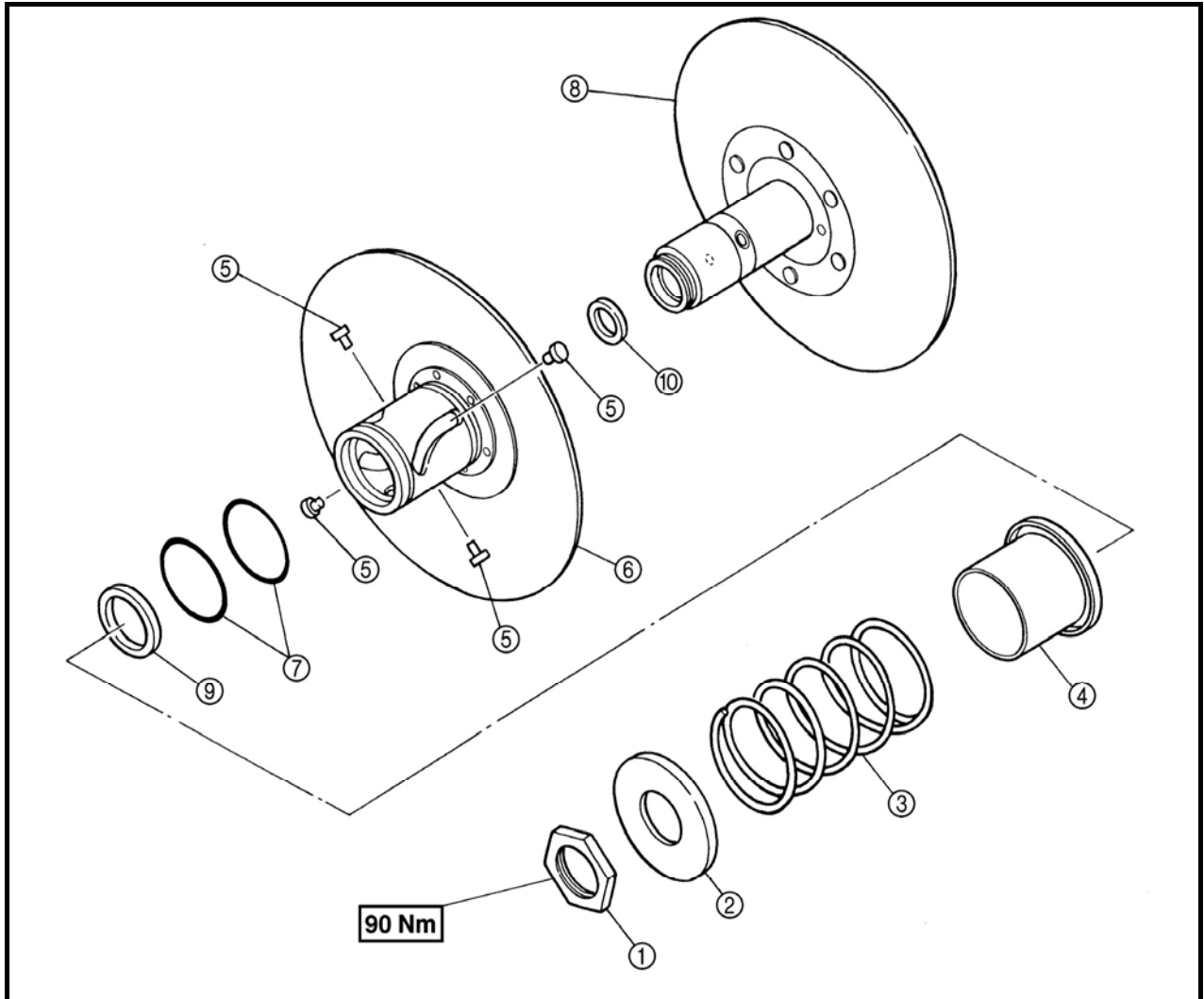

No.	Part Name	Qty	Remarks
	Disassembling the secondary Sheave		Remove the parts in the order listed.
1	Nut	1	
2	Spring seat	1	
3	Compression spring	1	
4	Spring seat	1	
5	Guide pin	4	
6	Secondary sliding sheave	1	
7	O-ring	2	
8	Secondary fixed sheave	1	
9	Oil seal	1	
10	Oil seal	1	
			For assembly, reverse the disassembly procedure.

ENGINE

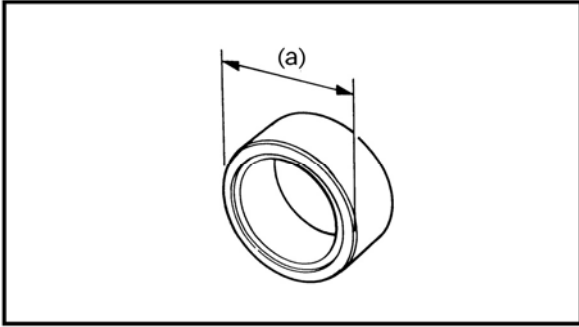

1、 Check

1). Checking the primary sheave

- weight outside diameter (a)

Out of specification → Replace the weight.

Weight outside diameter limit: 29.5 mm

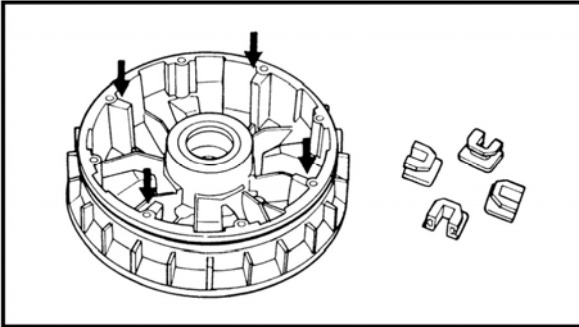

- primary pulley slider
 - primary sliding sheave splines
- Wear/cracks/damage → Replace.

- spacer
 - primary pulley cam
- Cracks/damage → Replace.

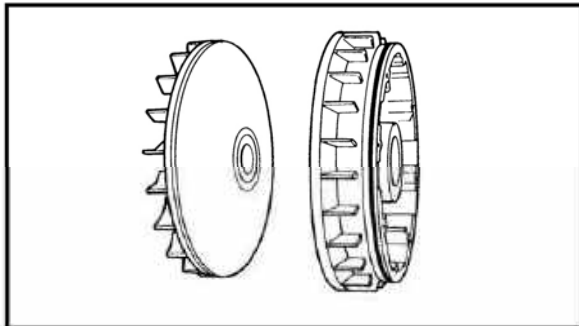

- primary sliding sheave
 - primary fixed sheave
- Cracks/damage → Replace.

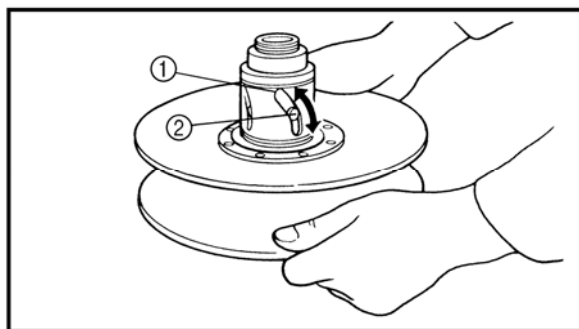

2). Checking the secondary sheave

- secondary fixed sheave smooth operation
 - secondary sliding sheave smooth operation
- Scratches/damage → Replace as a set.

- torque cam grooves ①
- Wear/damage → Replace

- guide pins ②
- Wear/damage → Replace.

- secondary sheave spring
- Damage → Replace.

ENGINE

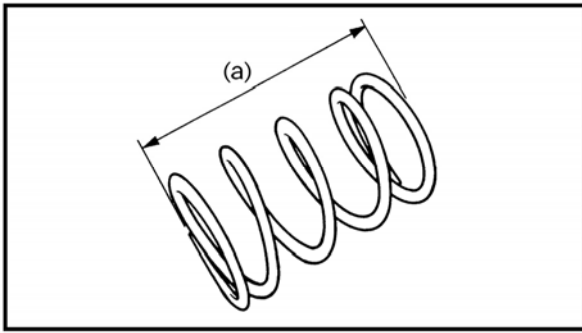

2、 Measure

- secondary sheave spring free length (a)
- Out of specification → Replace the secondary sheave spring.

3、 INSTALL

1). Assembling the primary sheave

(1) Clean:

- primary sliding sheave face ①
- primary fixed sheave face ②
- collar ③
- weights ④
- primary sliding sheave cam face

NOTE:

Remove any excess grease.

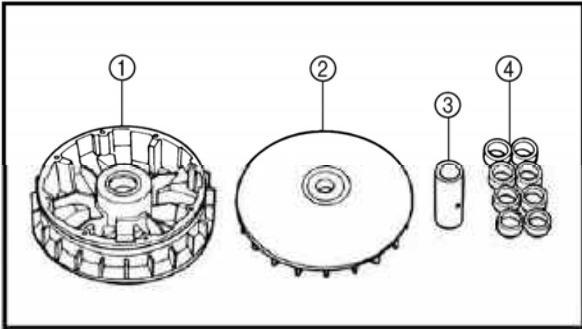

(2) Install:

- weights ①

NOTE:

- Apply grease (90g) to the whole outer surface of the weights and install.
- Apply grease to the inner surface of the collar.
- Apply grease to the inner surface of the primary sliding sheave.

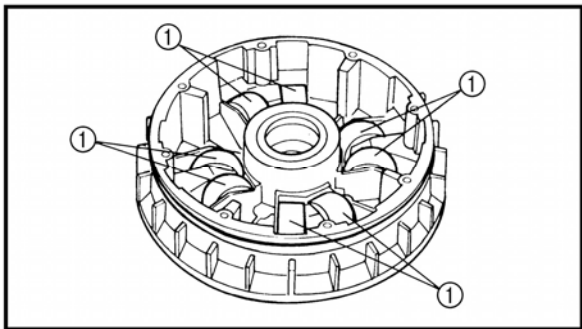

- spacer
- sliders ①
- primary pulley cam ②
- primary sliding sheave cap (3 Nm)

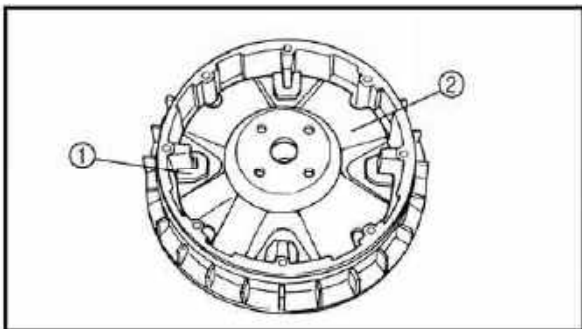

ENGINE

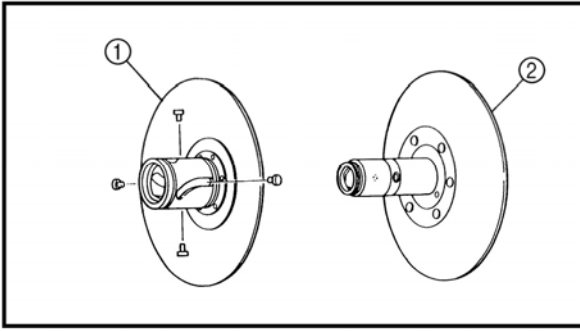

2). Assembling the secondary sheave

(1)Apply:

- assembly lube
(to the secondary sliding sheave ① inner surface and oil seals).
- assembly lube
(to the bearings, oil seals and inner surface of the secondary fixed sheave ②)

(2)Install:

- guide pins ①
- spring seat
- compression spring
- spring seat
- nut

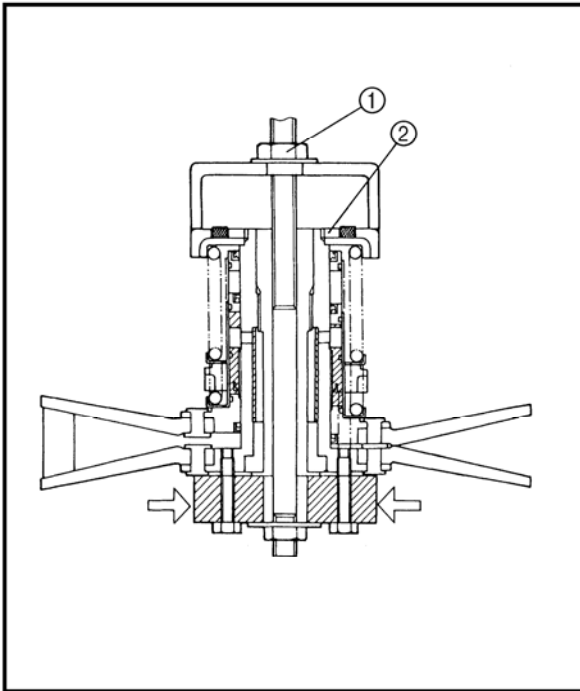
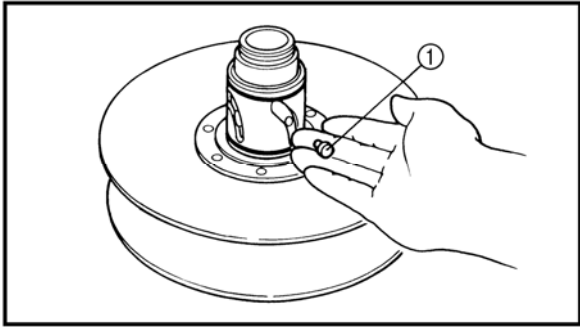

- a. Attach the sheave fixed block, locknut wrench and sheave spring compressor to the secondary sheave assembly.
- b. Place the sheave fixed block in a vise and secure it.
- c. Tighten the sheave spring compressor nut ① and compress the spring.
- d. Install the nut ② and tighten it to the specified torque using the locknut wrench.(Nut:90Nm)
- e. Remove the sheave spring compressor, locknut wrench, and sheave fixed block.

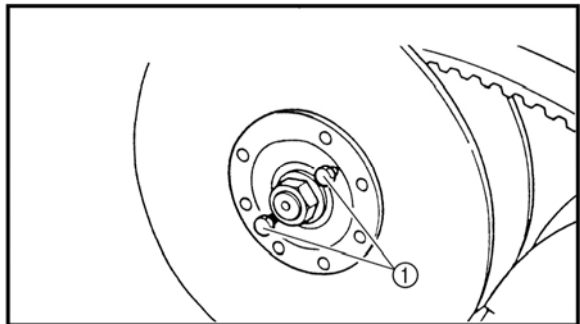

3). Installing the primary and secondary sheaves

(1) Install:

- secondary sheave assembly
- V-belt
- primary sheave assembly

ENGINE

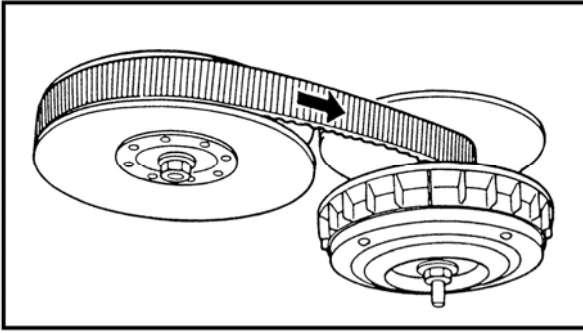

NOTE:

- Tightening the bolts ① will push the secondary sliding sheave away, causing the gap between the secondary fixed and sliding sheaves to widen.
 - Install the V-belt so that its arrow faces the direction show in the illustration.
-

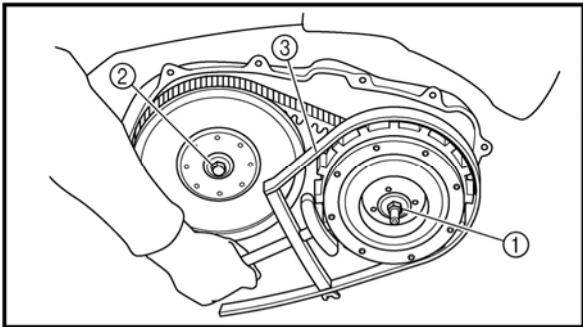

(2)Tighten:

- primary sheave nut ① (120Nm)
- secondary sheave nut ② (100Nm)

NOTE:

- Use the sheave holder ③ to hold the primary sheave.
 - First, tighten the primary sheave nut ①, then tighten the secondary sheave nut ②.
-

ENGINE

CLUTCH

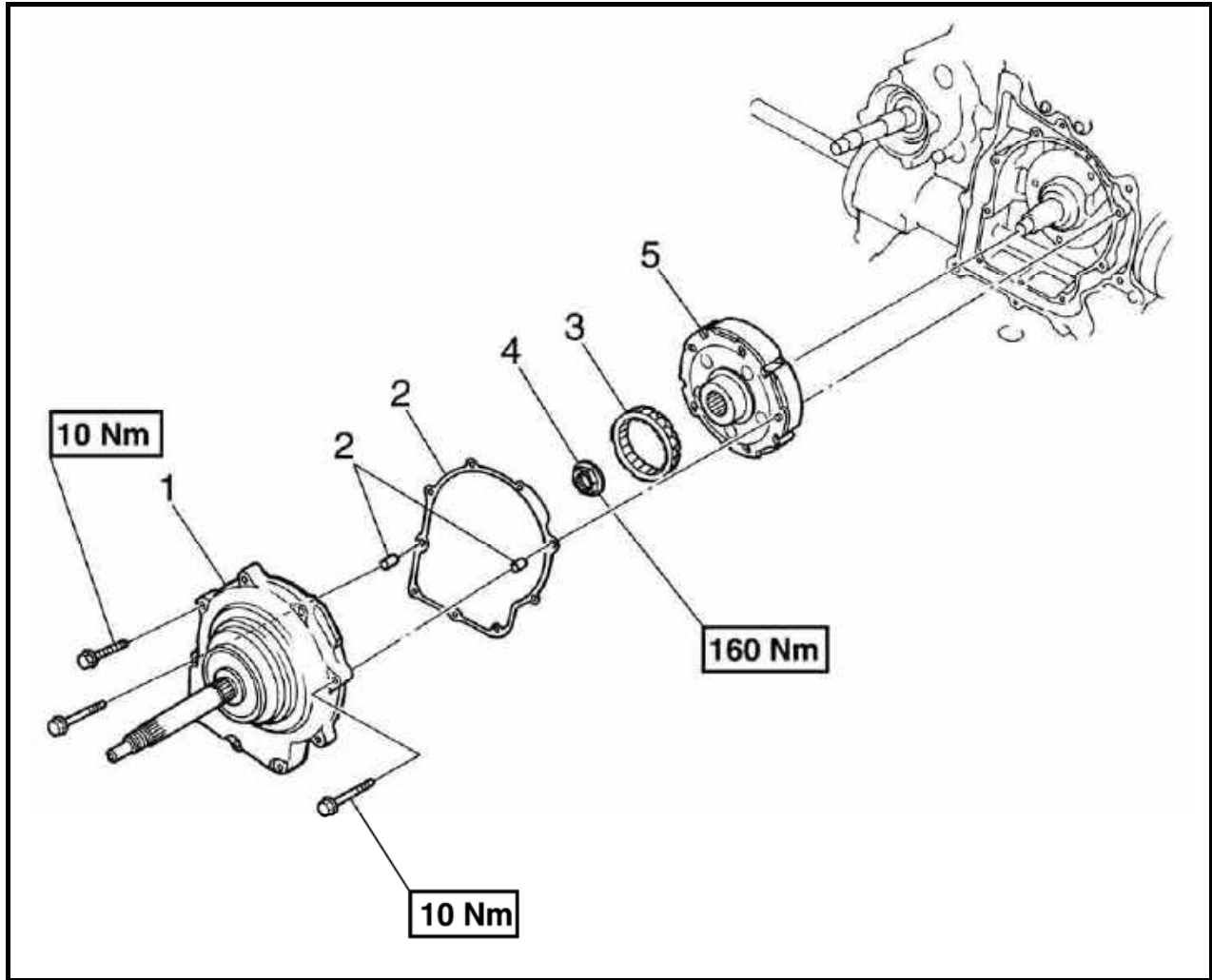

No.	Part Name	Qty	Remarks
	Removing the clutch		
	Primary and secondary sheaves		Remove the parts in the order listed.
1	Clutch housing assembly	1	
2	Gasket/dowel pin	1/2	
3	One-way clutch bearing	1	
4	Nut	1	
5	Clutch carrier assembly	1	
			For installation, reverse the removal procedure.

ENGINE

CLUTCH HOUSING

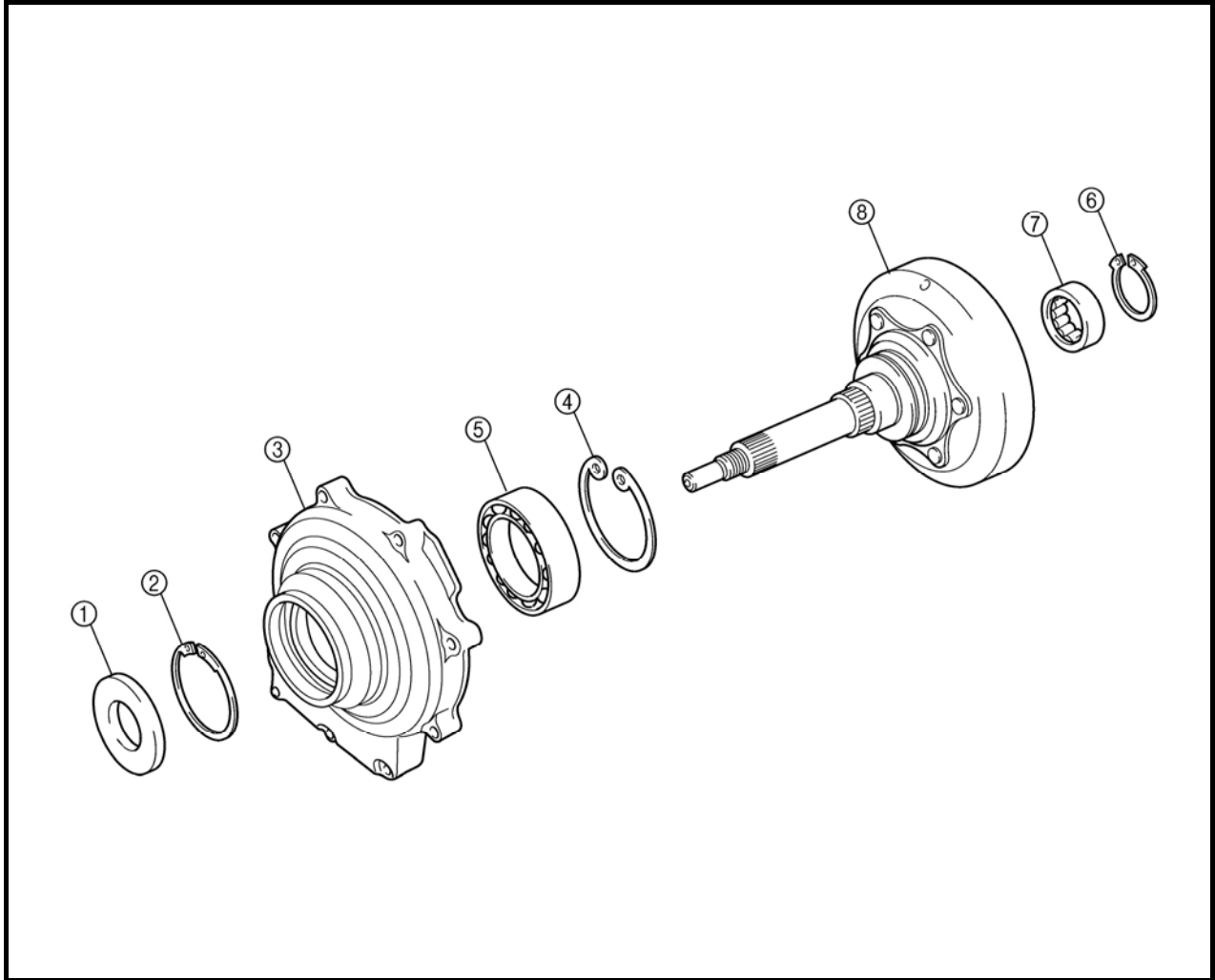

No.	Part Name	Qty	Remarks
	Disassembling the clutch housing		Remove the parts in the order listed.
1	Oil seal	1	
2	Circlip	1	
3	Bearing housing	1	
4	Circlip	1	
5	Bearing	1	
6	Circlip	1	
7	Bearing	1	
8	Clutch housing	1	
			For assembly, reverse the disassembly procedure.

ENGINE

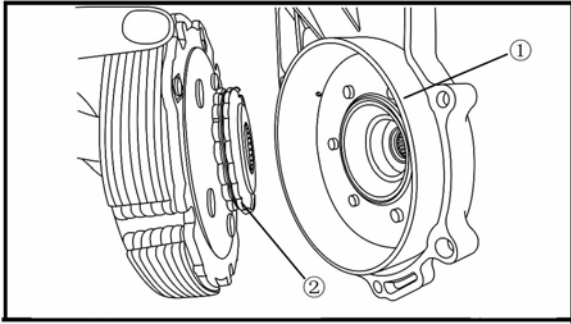

1、CHECK

1). Checking the clutch

- clutch housing ①
Heat damage/wear/damage → Replace.
- one-way clutch bearing ②
Chafing/wear/damage → Replace.

NOTE:

- **Replace the one-way clutch assembly and clutch housing as a set.**
- **The one-way clutch bearing must be installed with the flange side facing in.**

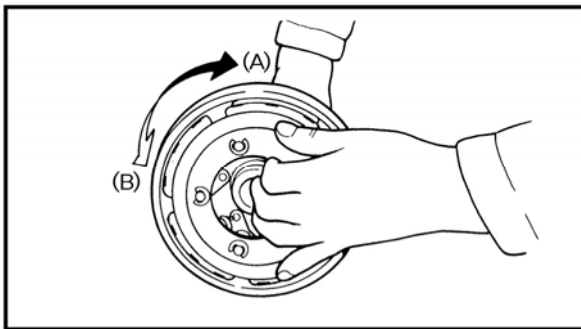

- Install the one-way clutch bearing and clutch carrier assembly to the clutch housing and hold the clutch carrier assembly.
 - When turning the clutch housing clockwise (A), the clutch housing should turn freely. If not, the one-way clutch assembly is faulty. Replace it.
 - When turning the clutch housing counter-clockwise (B), the clutch housing and crankshaft should be engaged. If not, the one-way clutch assembly is faulty. Replace it.
- clutch shoe
Heat damage → Replace.

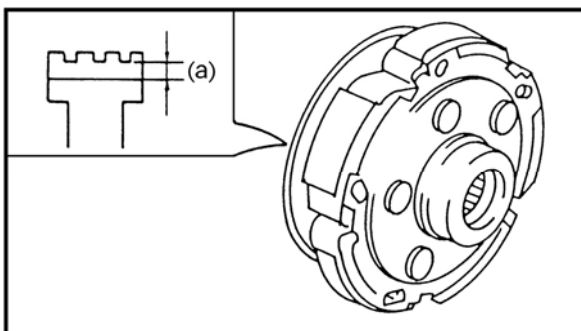

2、MEASURE

- clutch shoe thickness
Out of specification → Replace.

Clutch shoe wear limit (a)

1.0 mm

ENGINE

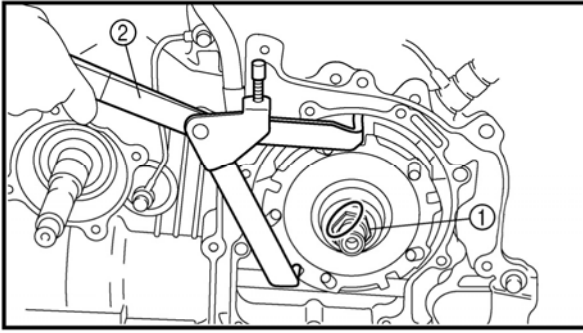

3、INSTALL

- clutch carrier assembly
- nut ①(160Nm)

NOTE:

Use a universal clutch holder ② to hold the clutch carrier assembly.

- Lock the threads with a drift punch.

- one-way clutch bearing

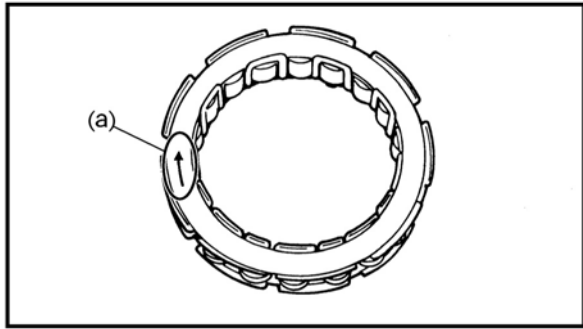

NOTE:

The one-way clutch bearing should be installed in the clutch carrier assembly with the arrow mark (a) facing toward the clutch housing.

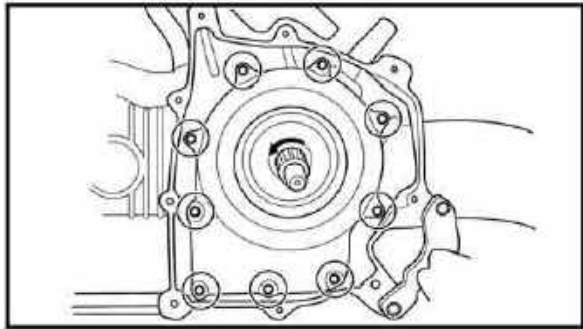

- dowel pins
- gasket
- clutch housing assembly
(10 Nm)

NOTE:

- Tighten the bolts in stages, using a crisscross pattern.
- After tightening the bolts, check that the clutch housing assembly to counterclockwise rotates smoothly.

ENGINE

CRANKCASE STARTER MOTOR AND OIL FILTER

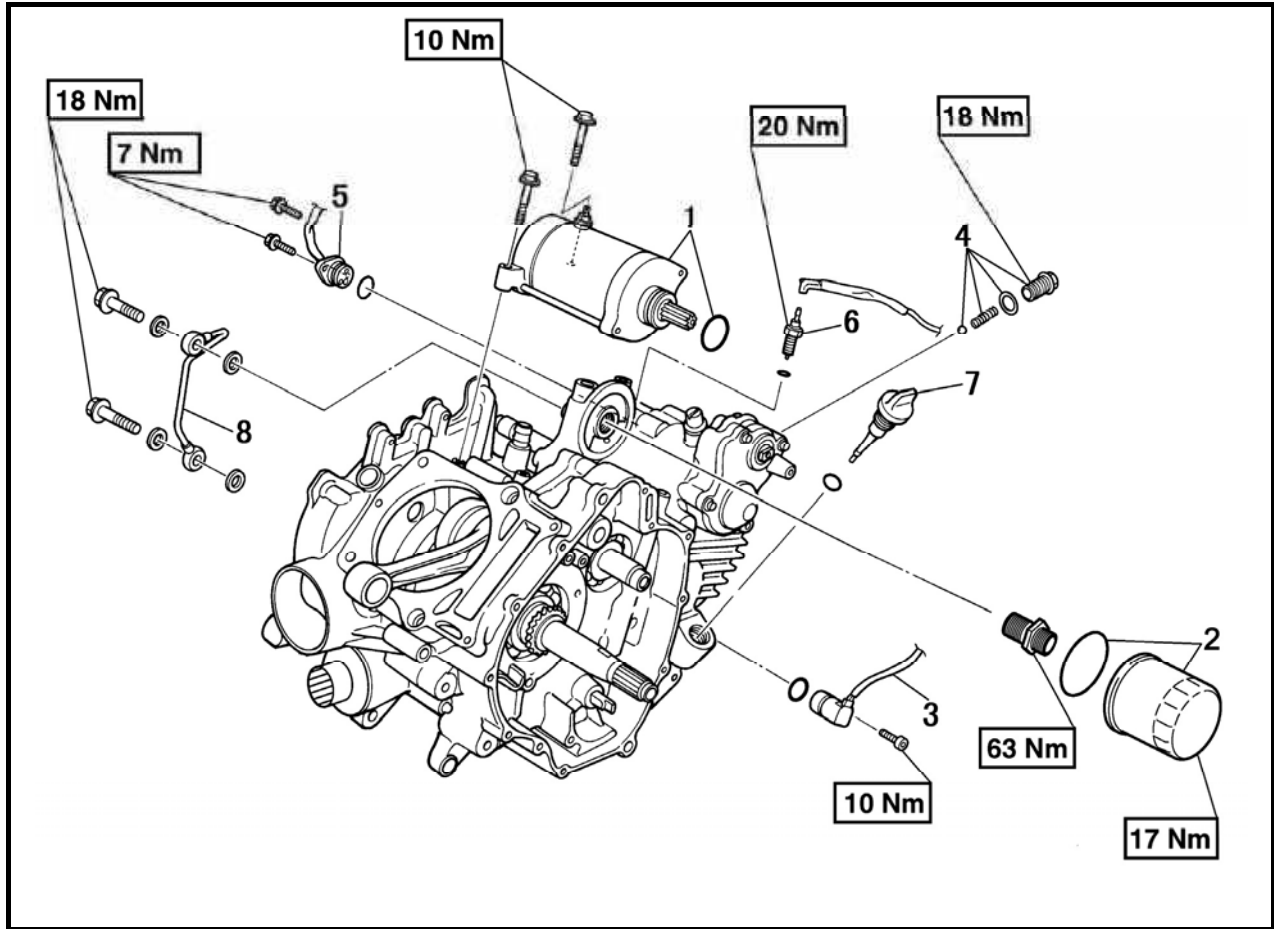

No.	Part Name	Qty	Remarks
	Remove the starter motor, timing chain and oil filter		Remove the parts in the order listed.
	A.C. magneto rotor		
	Primary and secondary sheaves		
	Clutch carrier assembly		
1	Starter motor/O-ring	1/1	
2	Oil filter cartridge/O-ring	1	
3	Speed sensor	1	
4	Shift drum stopper	1	
5	Gear position switch	1	
6	Reverse switch	1	
7	Oil filler cap	1	For installation, reverse the removal procedure.
8	Oil delivery pipe 1	1	

ENGINE

CRANKCASE

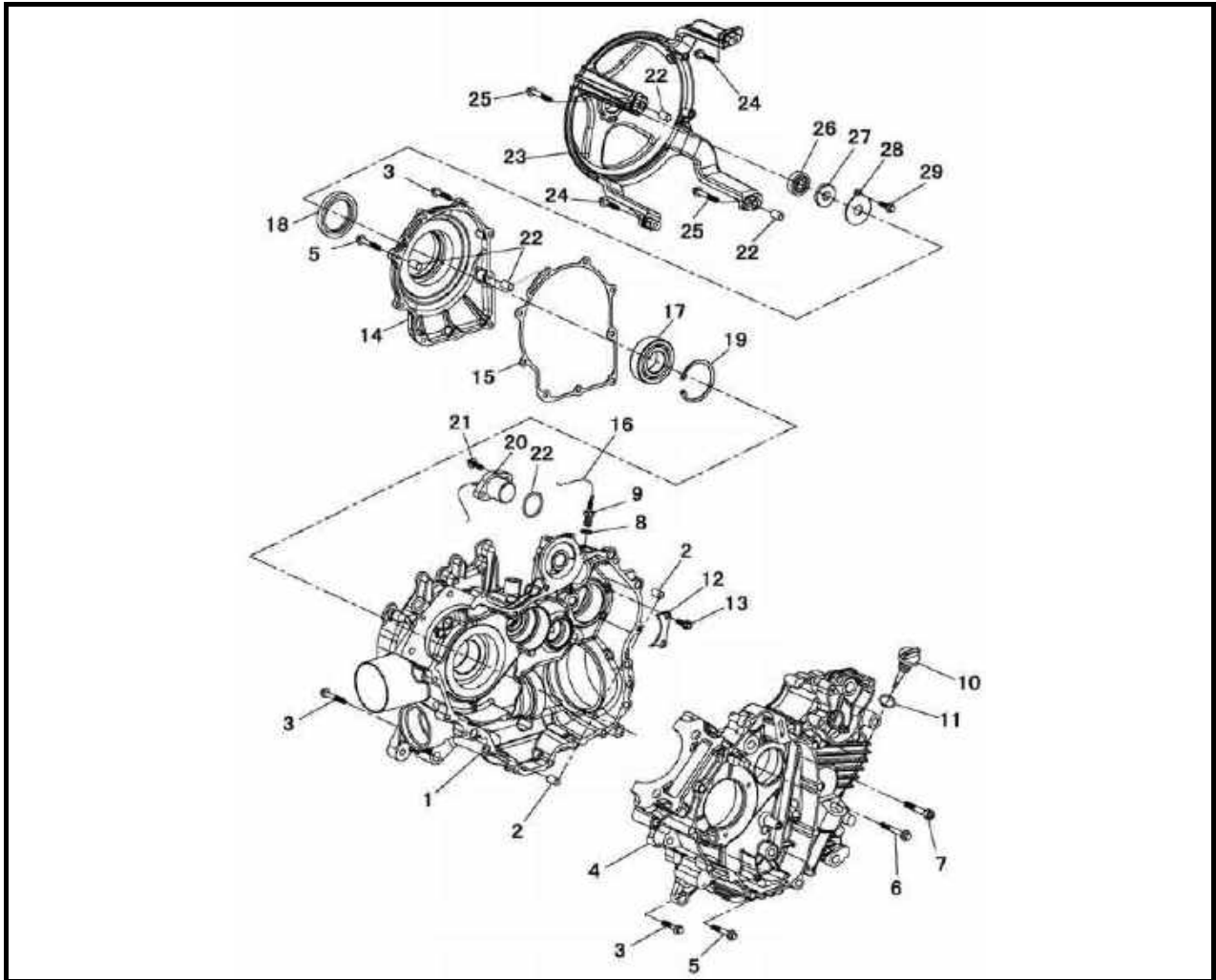

No.	Part Name	Qty	Remarks
	Separating the crankcase		Remove the parts in the order listed.
1	Right crankcase comp	1	
2	Dowel Pin $\phi 9 \times \phi 12 \times 16$	2	
3	Flange bolt M6 \times 30	19	
4	Left crankcase comp	1	
5	Flange bolt M6 \times 40	4	
6	Flange bolt M6 \times 55	1	
7	Inner hexangular screw M8 \times 40	3	
8	Gear switch	1	
9	Washer $\phi 10 \times \phi 16 \times 1$	1	
10	Gauge oil level	1	
11	O-ring 18 \times 2.4	1	
12	Press plate-main shaft bearing	1	

ENGINE

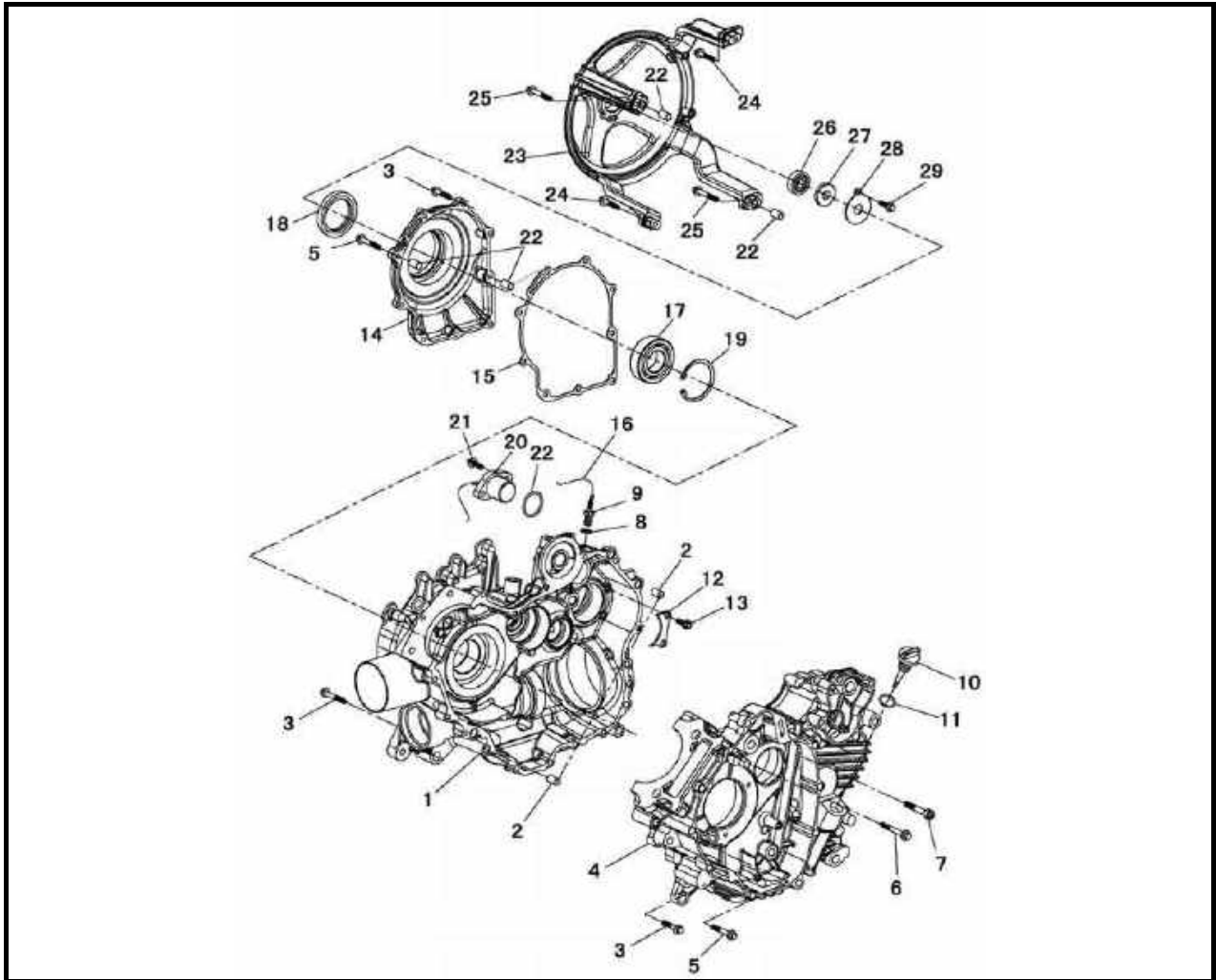

No.	Part Name	Qty	Remarks
13	Flange bolt M6×16	2	
14	Bearing seat outer cover	1	
15	Seal cushion bearing seat	1	
16	Leads Gear	1	
17	Bearing 16010	1	
18	Oil seal 35×65×9	1	
19	Circlip φ 80	1	
20	Gear show assy	1	
21	Bolt M6×16	2	
22	Flange bolt M6×20	2	
23	Protection cover brack tcluth	1	
24	Flange bolt M6×32	2	
25	Flange bolt M6×40	2	

ENGINE

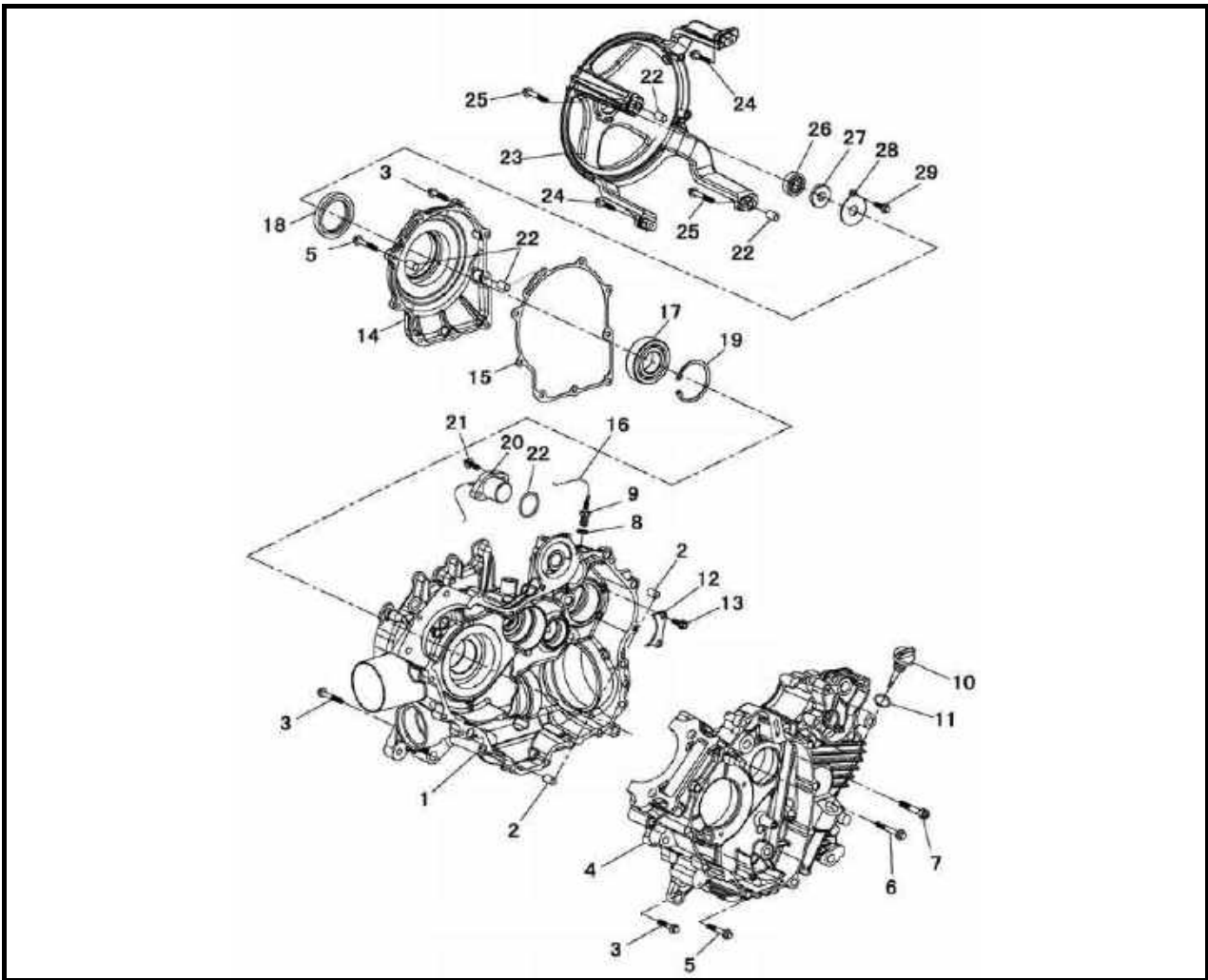

No.	Part Name	Qty	Remarks
26	Bearing 62012Z	1	
27	Oil seal 12x32x6	1	
28	Oil press plate	1	
29	Flange bolt M6x12	1	
			For installation, reverse the removal procedure.

ENGINE

CRANKCASE BEARINGS

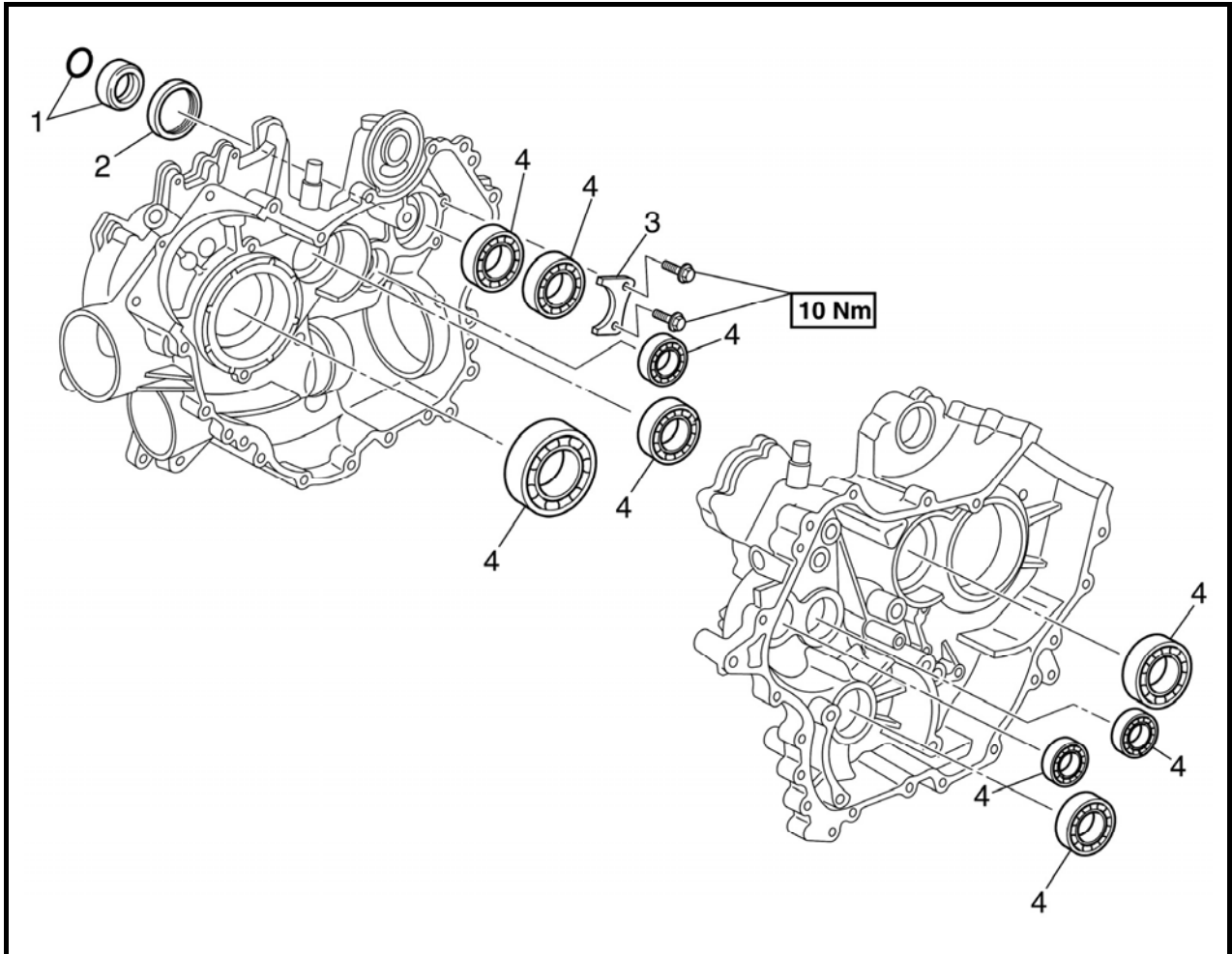

No.	Part Name	Qty	Remarks
	Removing the crankcase bearings		Remove the parts in the order listed.
	Crankshaft and oil pump		
	Transmission		
	Middle drive/driven shaft		
1	O-ring/collar	1/1	
2	Oil seal	1	
3	Bearing retainer	1	
4	Bearing	9	
			For installation, reverse the removal procedure.

ENGINE

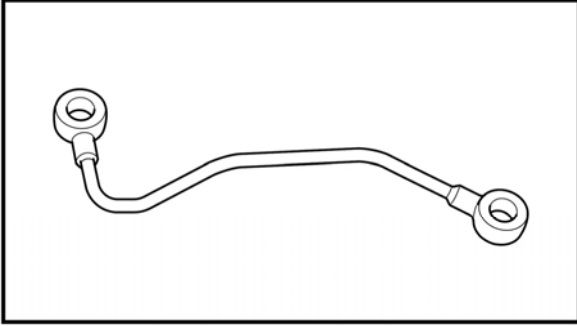

1. CHECK

1). Checking the oil delivery pipe

- oil delivery pipe

Cracks/damage → Replace.

Clogged → Blow out with compressed air.

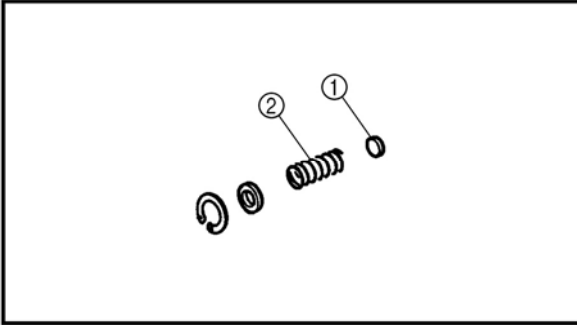

2). Checking the relief valve

- relief valve ①

- spring ②

Damage/wear → Replace the defective part(s).

3). Checking the crankcase

(1) Thoroughly wash the case halves in a mild solvent.

(2) Clean all the gasket mating surfaces and crankcase mating surfaces thoroughly

(3) check:

- crankcase

Cracks/damage → Replace.

- oil delivery passages

Clogged → Blow out with compressed air.

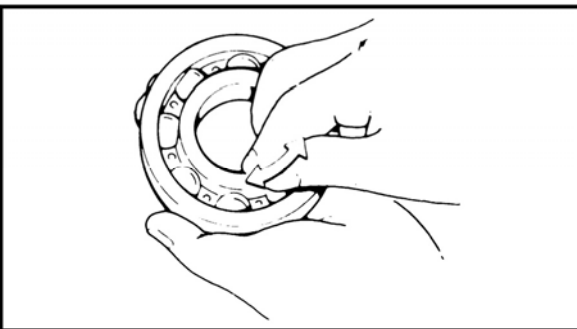

4). Checking the bearings

(1) Check:

- bearings

Clean and lubricate, then rotate the inner race with a finger.

Roughness → Replace

ENGINE

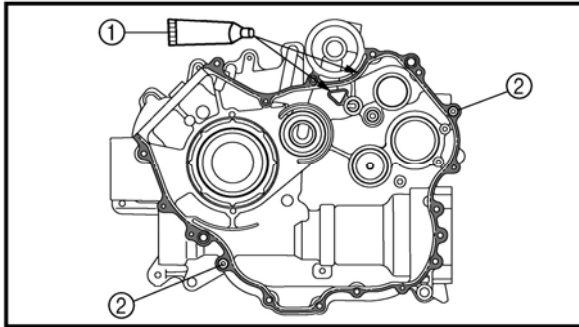

2、INSTALL

1). Assembling the crankcase

(1) Apply:

- sealant (Quick Gasket) ①
(to the mating surfaces of both case halves)

(2) Install:

- dowel pins ②

(3) Fit the left crankcase onto the right case. Tap lightly on the case with a soft hammer

CAUTION:

Before installing and torque the crankcase holding bolts, be sure to check whether the transmission is functioning properly by manually rotating the shift drum in both directions.

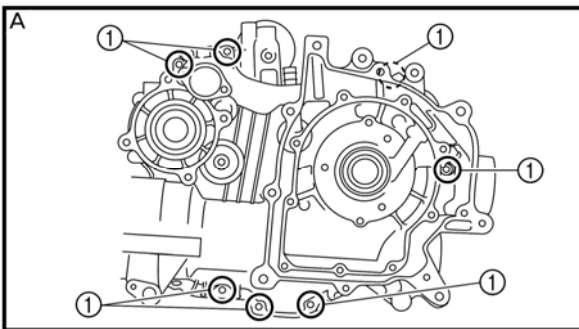

(4)Tighten:

- crankcase bolts ①, ② (10Nm)
(follow the proper tightening sequence)
- crankcase bolts ③ (26Nm)
(follow the proper tightening sequence)

A Left crankcase

B Right crankcase

NOTE:

- Tighten the bolts in stages, using a crises cross pattern.
- Apply sealant (Quick Gasket) ④ to the thread of the bolt ② shown in the illustration

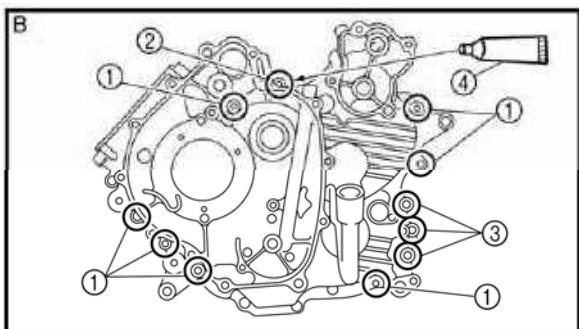

(5) Apply:

- 4-stroke engine oil
(to the crank pin, bearing and oil delivery hole)

ENGINE

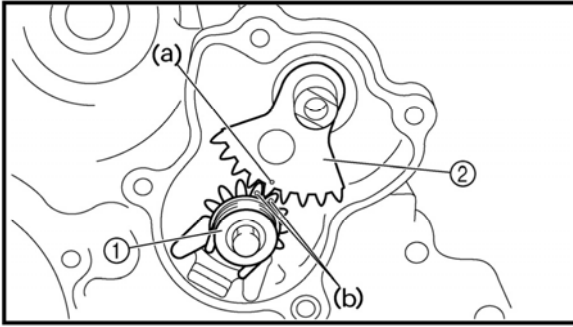

2). Installing the shift levers

- shift lever 2 assembly ① (14Nm)
- shift lever 1 ②

NOTE:

When installing the shift lever 1, align the punch mark (a) on the shift lever 1 with the punch marks (b) on the shift lever 2.

ENGINE

CRANKSHAFT AND OIL PUMP

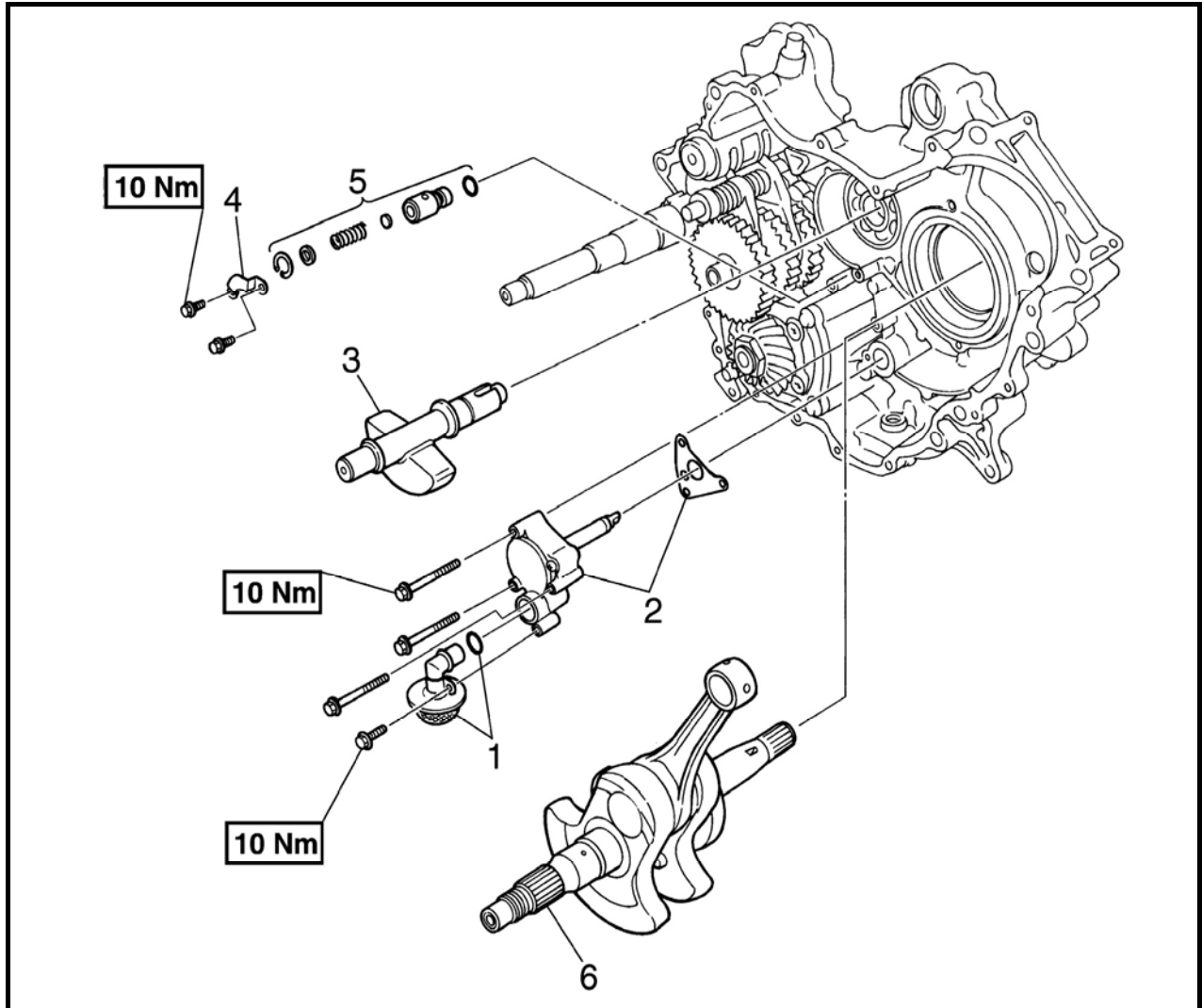

No.	Part Name	Qty	Remarks
	Removing the crankshaft and oil pump		Remove the parts in the order listed. For installation, reverse the removal procedure.
	Crankcase separation		
1	Oil strainer/O-ring	1/1	
2	Oil pump assembly/gasket	1/1	
3	Balancer	1	
4	Plate	1	
5	Relief valve assembly	1	
6	Crankshaft	1	

ENGINE

OIL PUMP

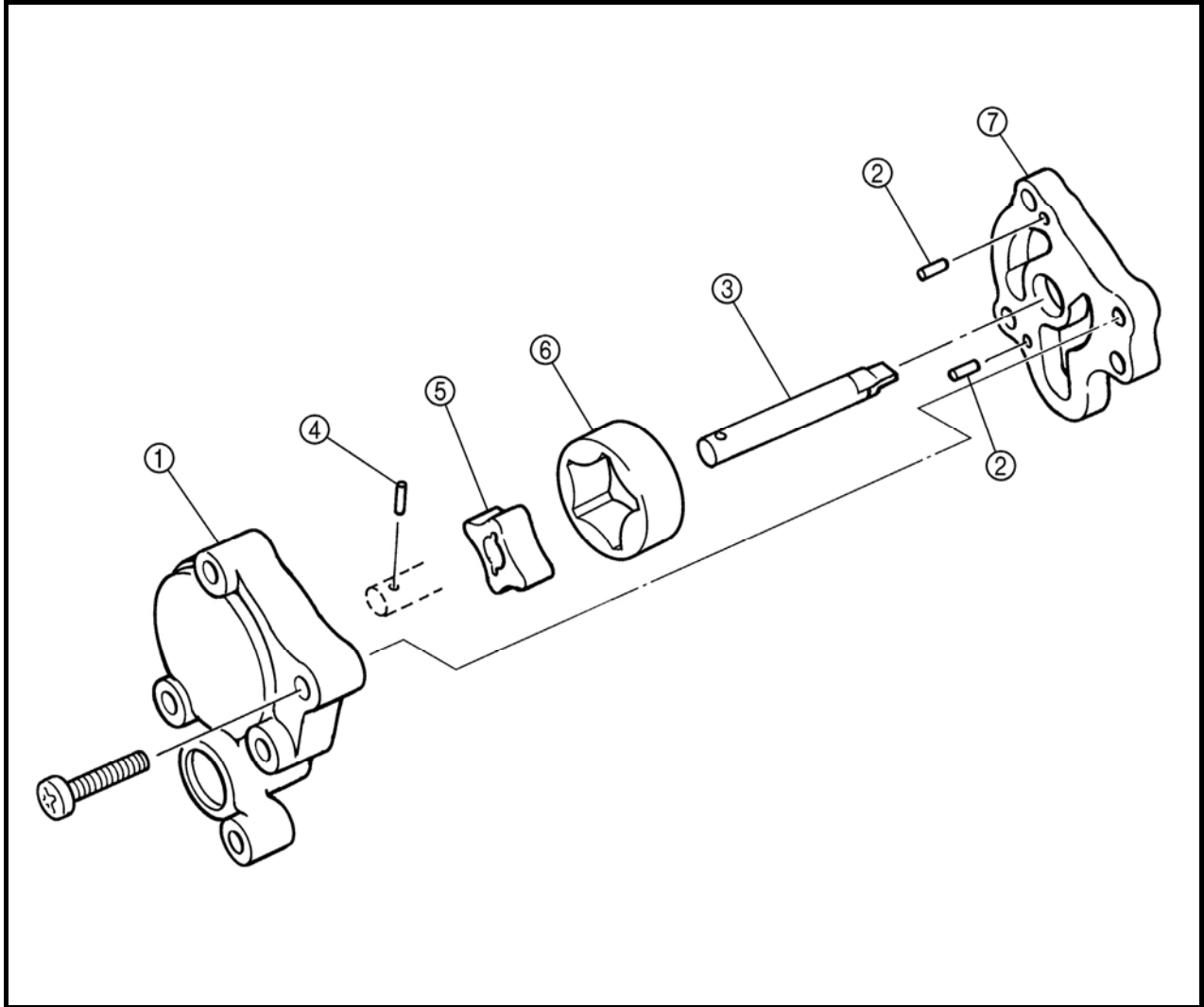

No.	Part Name	Qty	Remarks
	Disassembling the oil pump		Remove the parts in the order listed.
1	Rotor cover	1	
2	Pin	2	
3	Shaft	1	
4	Pin	1	
5	Inner rotor	1	
6	Outer rotor	1	
7	Oil pump housing	1	
			For assembly, reverse the disassembly procedure.

ENGINE

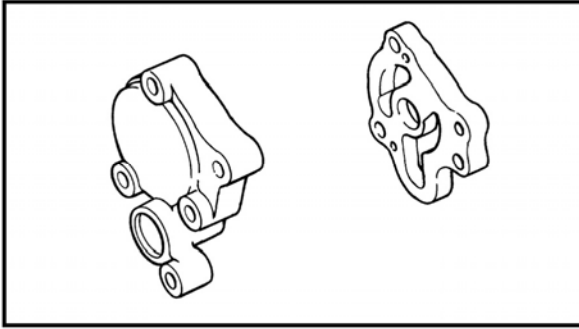

1、CHECK

1). Checking the oil pump

- rotor housing
- rotor cover
- Cracks/wear/damage → Replace.
- oil pump operation
- Unsmooth → Repeat steps #1 and #2 or replace the defective parts.

2). Checking the oil strainer

- oil strainer ①
- O-ring ②
- Damage → Replace.
- Contaminants → Clean with engine oil.

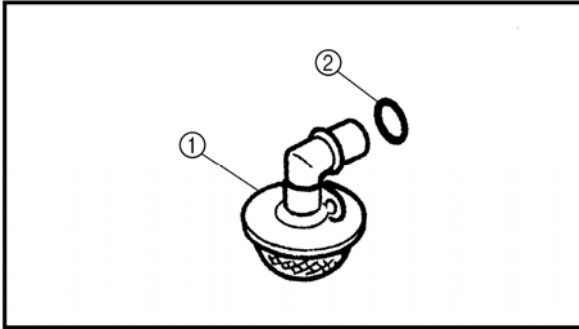

2、MEASURE

1). Measure the oil pump

- tip clearance(a)
- (between the inner rotor ① and the out rotor ②)
- ②)
- side clearance(b)
- (between the outer rotor ② and the pump housing ③)
- body clearance (c)
- (between the outer rotor ② and the pump housing ③)
- Out of specification → Replace the oil pump.

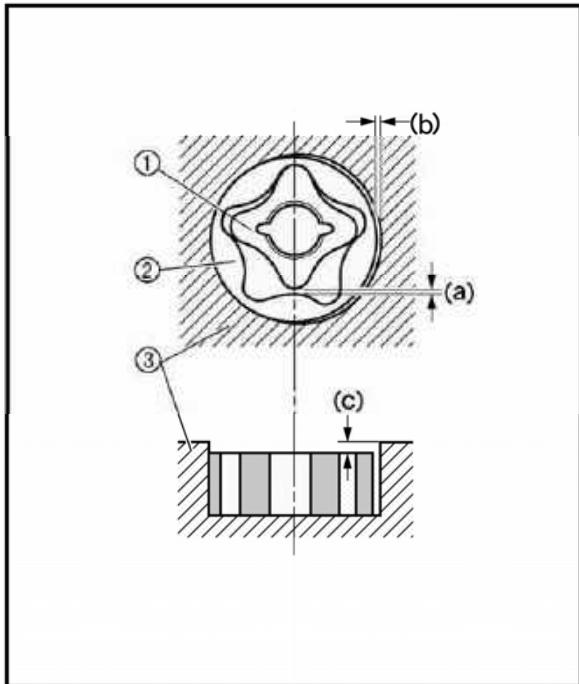

Tip clearance Limit: 0.23 mm

Side clearance Limit: 0.17 mm

Body clearance Limit: 0.24 mm

2). Measure the crankshaft

- crank width (A)
- Out of specification → Replace the crankshaft.

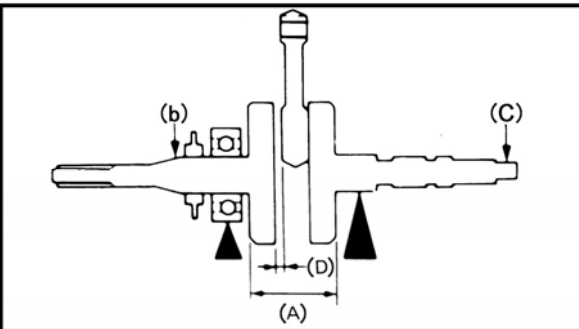

Crank width

74.95 ~ 75.00 mm

- side clearance (D)

Out of specification → Replace the crankshaf

ENGINE

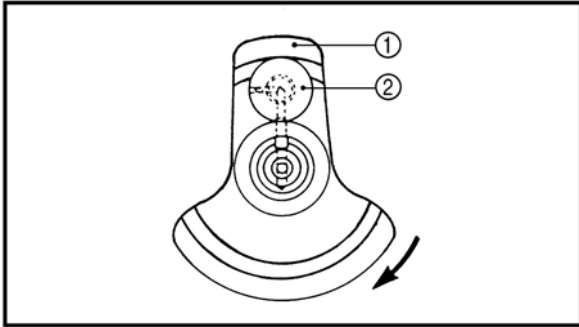

Big end side clearance

Limit: 1.0 mm (0.0394 in)

- runout (b)(C)

Out of specification → Replace the crankshaft.

Runout limit

(b): 0.03 mm (C): 0.03 mm

The crankshaft ① and the crank pin ② oil passages must be properly interconnected with a tolerance of less than 1 mm (0.04 in).

CAUTION:

The buffer boss and woodruff key should be replaced when removed from the crankshaft.

3、INSTALL

- 1). Assembling the oil pump

- inner rotor
- outer rotor
- oil pump shaft

(with the recommended lubricant)

- 2). Installing the crankshaft and balancer

- crankshaft

NOTE:

Hold the connecting rod at the Top Dead Center (TDC) with one hand while turning the nut of the installing tool with the other.

Operate the installing tool until the crankshaft bottoms against the bearing.

ENGINE

TRANSMISSION

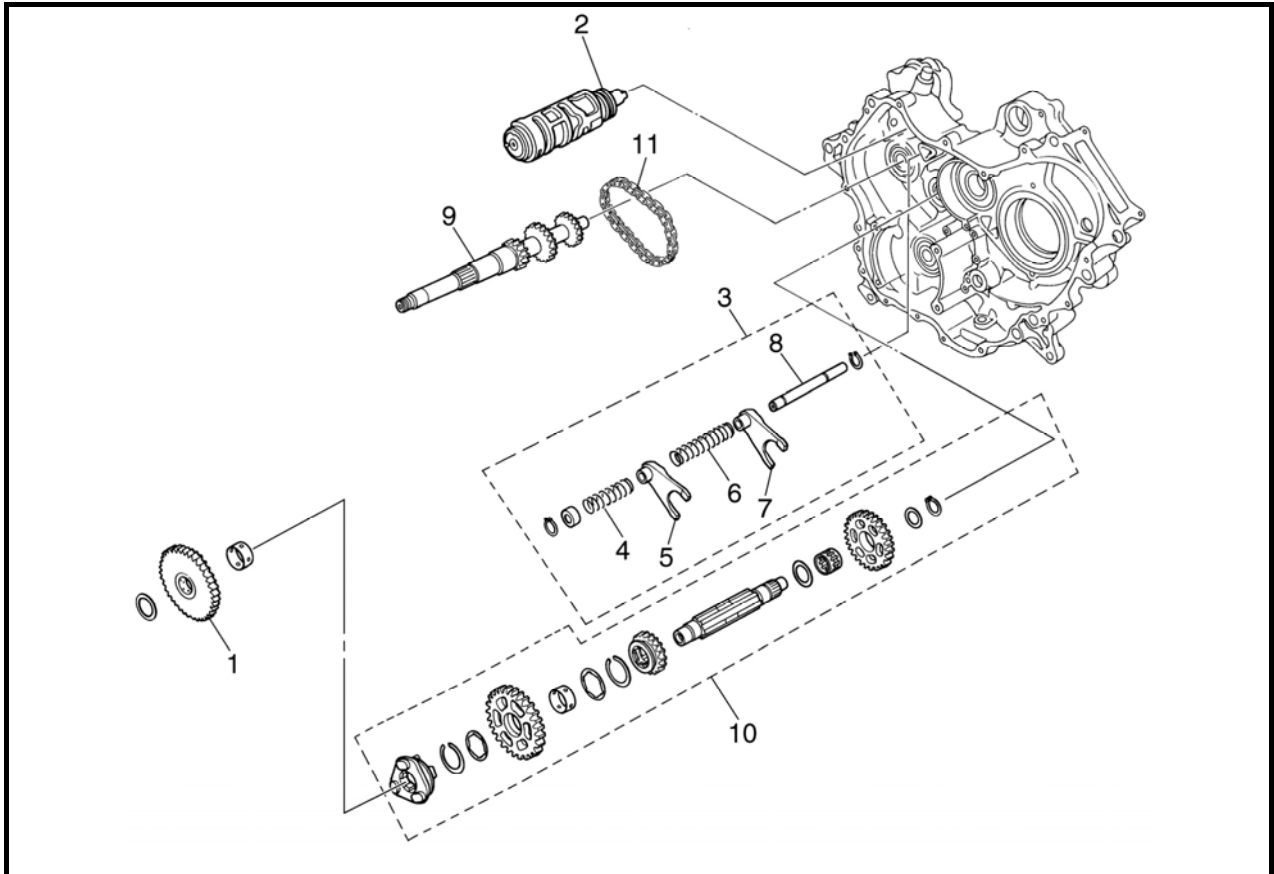

No.	Part Name	Qty	Remarks
	Removing the transmission		
	Crankcase separation		Remove the parts in the order listed.
	Middle driven gear		
1	Low wheel gear	1	
2	Shift drum	1	
3	Shift fork assembly	1	
4	Short spring	1	
5	Shift fork 1	1	
6	Long spring	1	
7	Shift fork 2	1	
8	Guide bar	1	
9	Secondary shaft	1	
10	Drive axle assembly	1	
11	Chain	1	
			For installation, reverse the removal procedure.

ENGINE

DRIVE AXLE ASSEMBLY

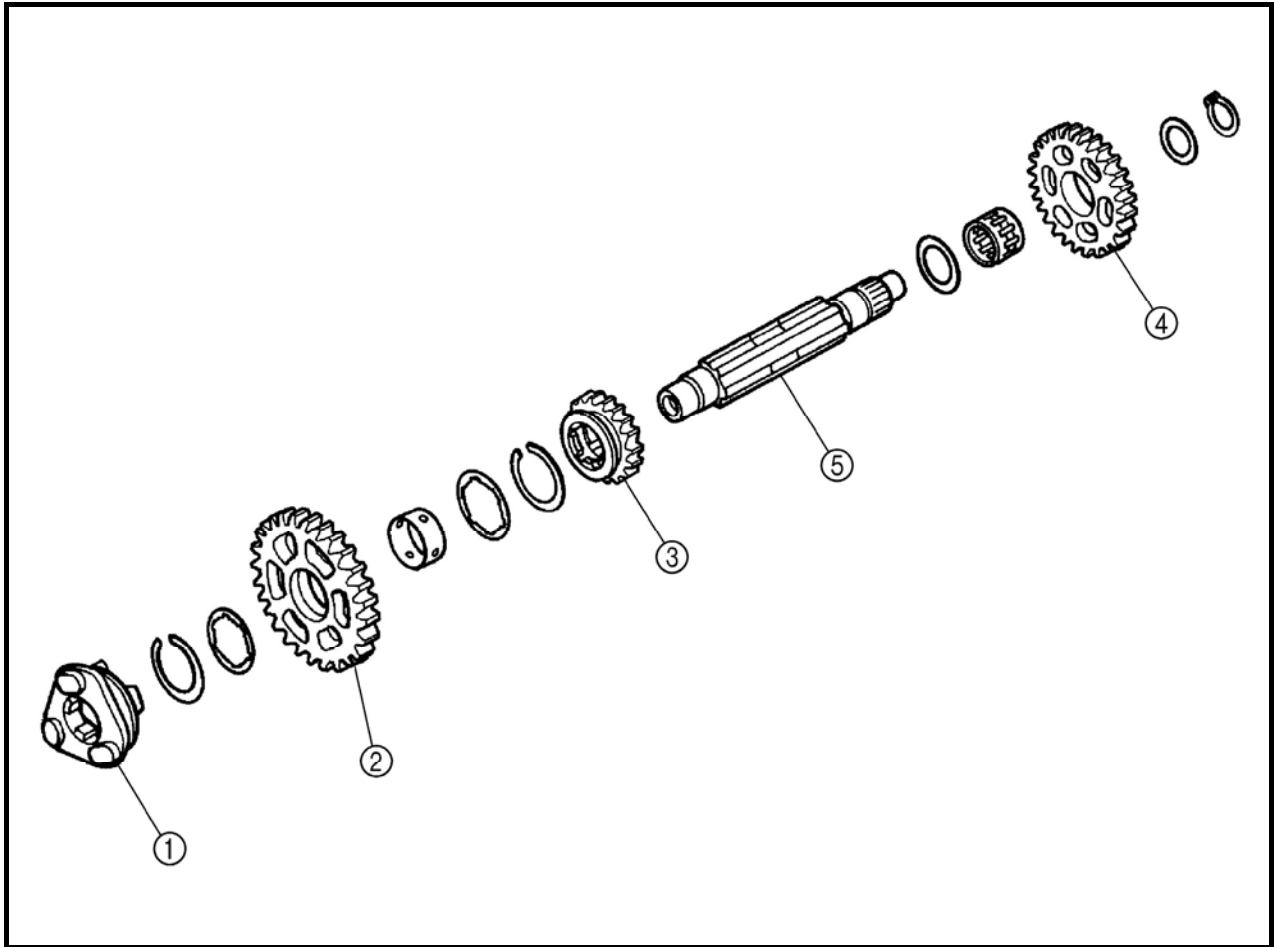

No.	Part Name	Qty	Remarks
	Disassembling the drive axle		Remove the parts in the order listed.
1	Clutch dog	1	
2	High wheel gear	1	
3	Middle drive gear	1	
4	Driven sprocket	1	
5	Drive axle	1	
			For assembly, reverse the disassembly procedure.

ENGINE

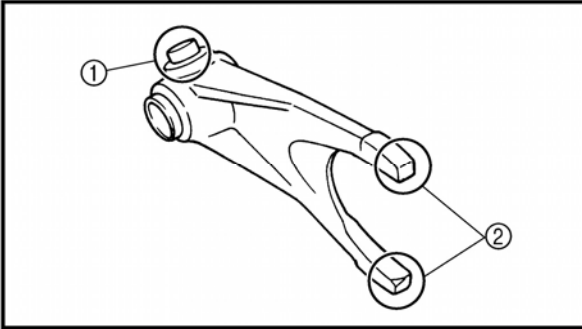

1. CHECK

1). Checking the shift forks

- shift fork follower ①
- shift fork pawl ②

Scoring/bends/wear/damage → Replace.

- guide bar

Roll the guide bar on a flat surface.

Bends → Replace.

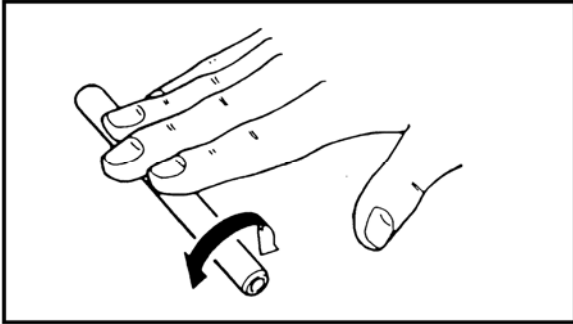

WARNING:

Do not attempt to straighten a bent guide bar.

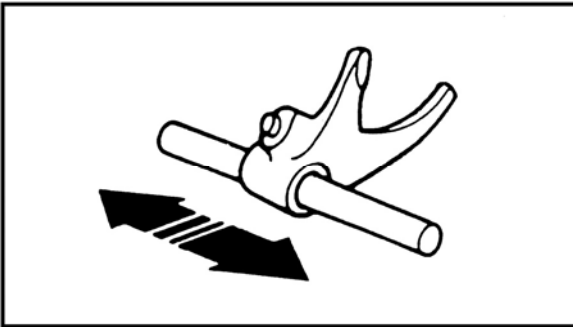

- shift fork movement
(on the guide bar)

Unsmooth operation → Replace the shift fork and the guide bar.

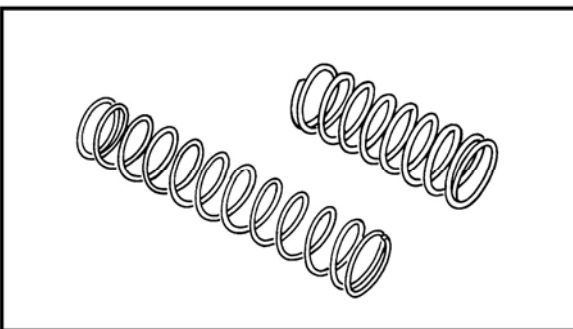

- springs

Cracks/damage → Replace.

2). Checking the shift drum

- shift drum grooves

Scratches/wear/damage → Replace.

ENGINE

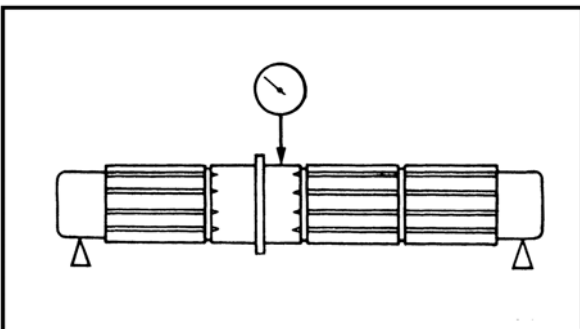
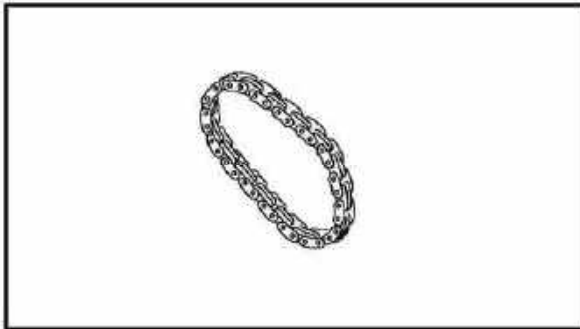
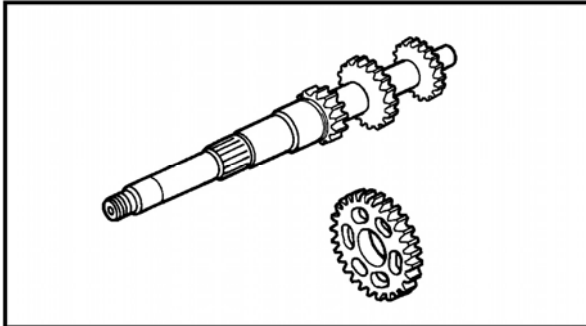
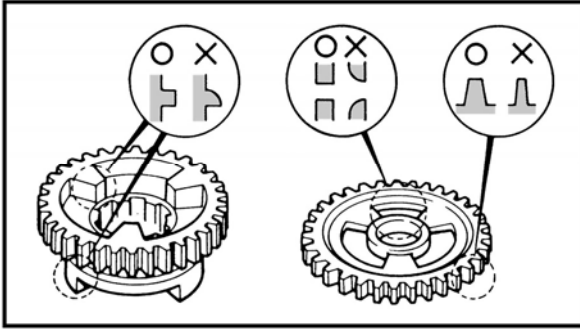

3). Checking the high wheel gear and middle drive gear

- gear teeth
Blue discoloration/pitting/wear → Replace.
- mated dogs
Rounded edges/cracks/missing portions
→ Replace.
- gear movement
Unsmooth → Repeat steps #1 or replace the defective parts.
- circlip
Bends/looseness/damage → Replace.

4). Checking the secondary shaft and driven sprocket

- gear teeth
Blue discoloration/pitting/wear → Replace.
- gear movement
Unsmooth → Repeat steps #1 or replace the defective parts.
- circlip
Bends/looseness/damage → Replace.

5). Checking the chain

- chain
Cracks/shift → Replace the chain, secondary shaft and driven sprocket as a set.

2. Measure:

- axle runout
Use a centering device and a dial gauge.
Out of specification → Replace the bent axle.

Drive axle runout limit
0.06 mm

ENGINE

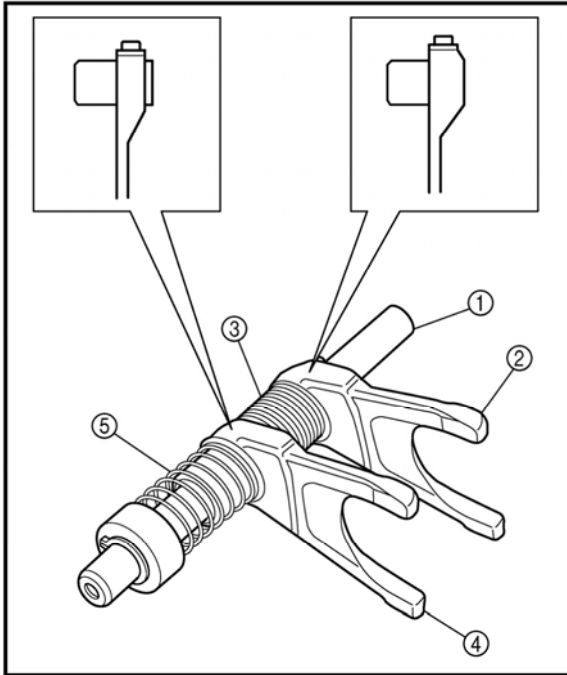

3. INSTALL

1). Assembling the shift fork

- guide bar ①
- shift fork 2 ②
- long spring ③
- shift fork 1 ④
- short spring ⑤

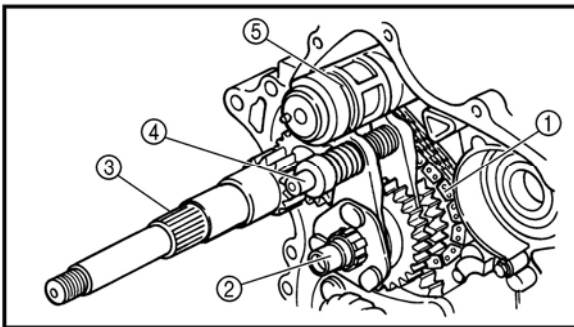

2). Installing the transmission

- chain ①
- drive axle assembly ②
- secondary shaft ③
- shift fork assembly ④
- shift drum ⑤
- low wheel gear

NOTE:

- Oil each gear and bearing thoroughly.
- Before assembling the crankcase, be sure hat the transmission is in neutral and that the gears turn freely.

ENGINE

MIDDLE GEAR

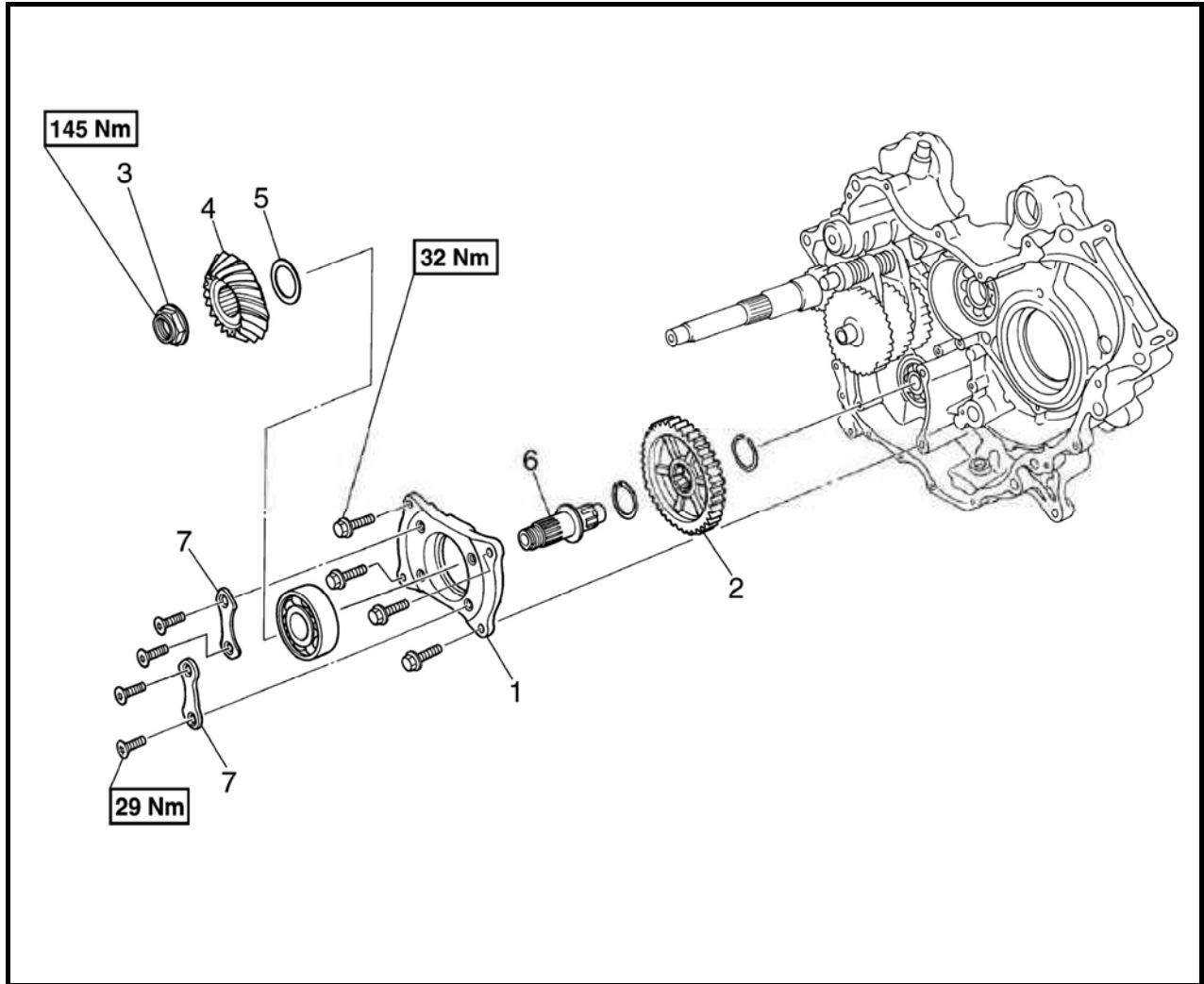

No.	Part Name	Qty	Remarks
	Removing the middle drive shaft		Remove the parts in the order listed. For assembly, reverse the disassembly procedure.
	Crankcase separation		
1	Bearing housing	1	
2	Middle drive gear	1	
3	Nut	1	
4	Middle drive pinion gear	1	
5	Shim	1	
6	Middle drive shaft	1	
7	Bearing retainer	2	

ENGINE

MIDDLE DRIVEN SHAFT

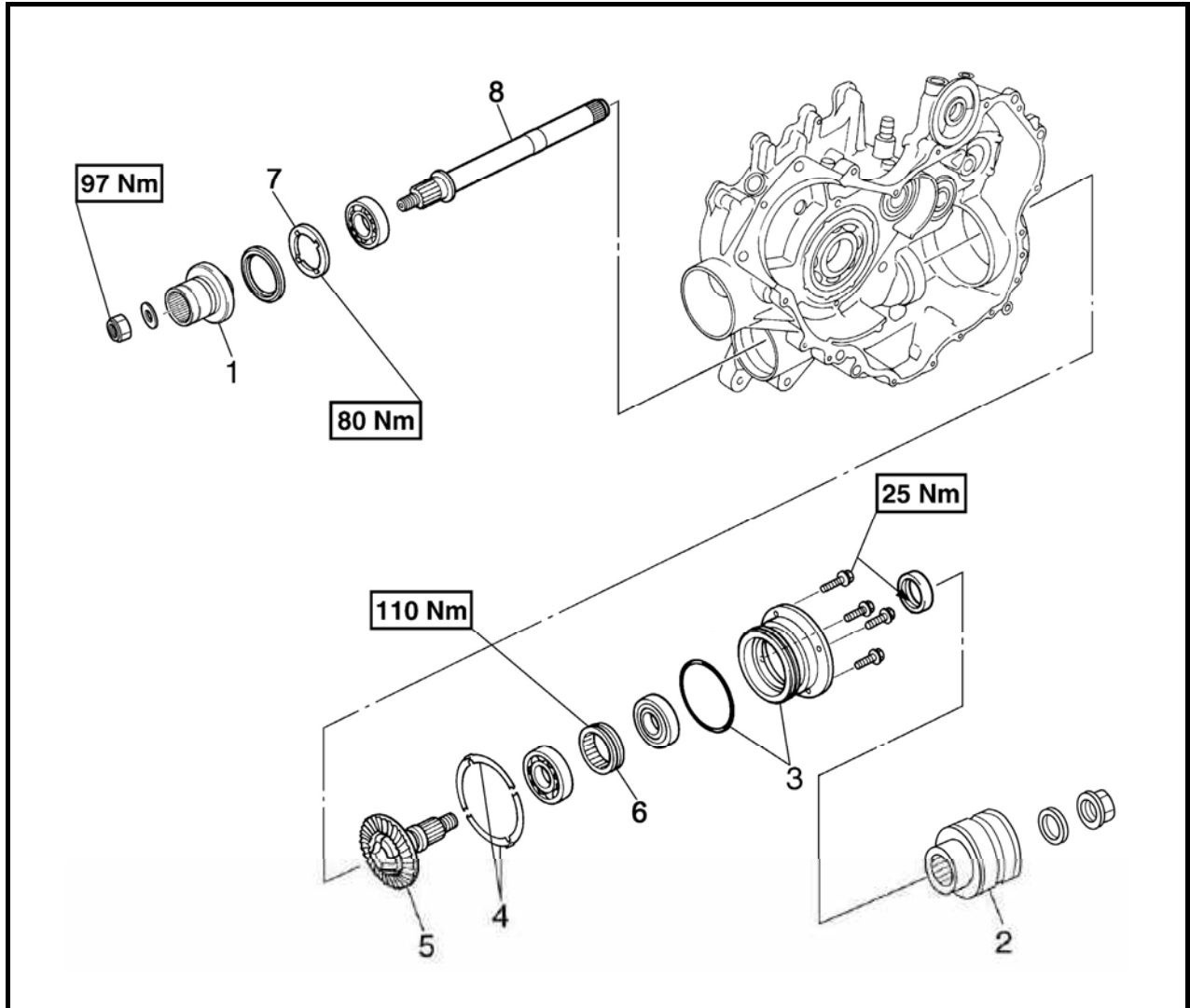

No.	Part Name	Qty	Remarks
	Removing the middle drive shaft		Remove the parts in the order listed.
	Crankcase separation		
1	Front drive shaft coupling	1	
2	Rear drive shaft coupling	1	
3	Bearing housing/O-ring	1/1	
4	Shim	1	
5	Middle driven pinion gear	1	
6	Bearing retainer	1	
7	Bearing retainer	1	
8	Middle driven shaft	1	
			For installation, reverse the removal procedure.

ENGINE

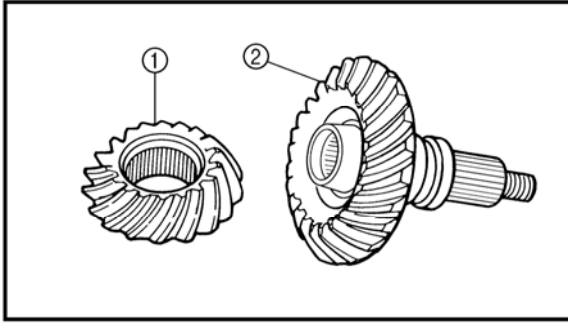

1、CHECK

- 1). Checking the pinion gears
 - gear teeth (drive pinion gear) ①
 - gear teeth (driven pinion gear) ②
 Pitting/galling/wear → Replace.
 - O-ring
 - Damage → Replace.
 - bearings
 - Pitting/damage → Replace.
 - universal joint movement
 - Roughness → Replace universal joint.

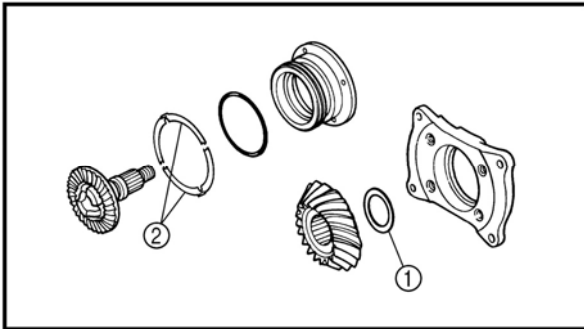

- 2). Selecting the middle drive and driven gear shims

When the drive and driven gear, bearing housing assembly and/or crankcase replaced, be sure to adjust the gear shims ① and ②.

 - middle drive gear shim ①
 - middle driven gear shim ②

2、MEASURE

- gear lash

Middle gear lash

0.1 ~ 0.3 mm

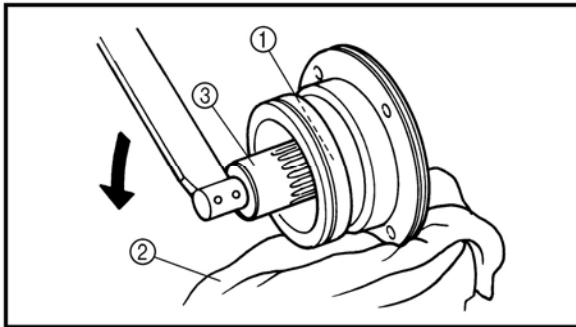

- a. Temporary install the left crankcase.
- b. Wrap a rag ① around a screwdriver ②, and then insert it into the installation hole ③ of the right crankcase speed sensor to hold the middle driven gear.
- c. Attach the gear lash measurement tool ④ and dial gauge ⑤.
 - a) 6.7 mm (0.26 in)
- d. Measure the gear lash while rotating the middle driven shaft back and forth.

NOTE:

Measure the gear lash at 4 positions. Rotate the middle driven gear 90° each time.

If the gear lash is incorrect, adjust the gear lash by middle driven pinion gear shims and/or middle drive pinion gear shim(s).

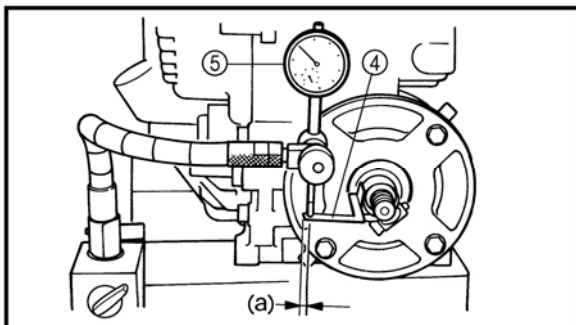

ENGINE

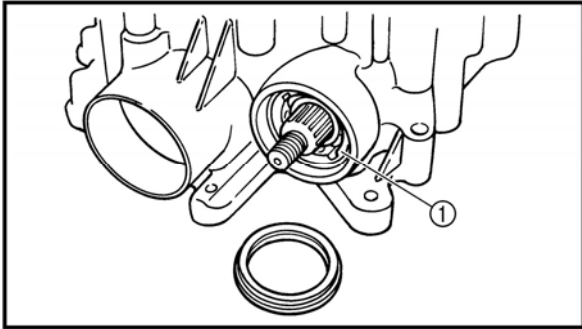

3、INSTALL

- 1). Installing the middle driven shaft
 - bearing retainer ①

Bearing retainer
80 Nm

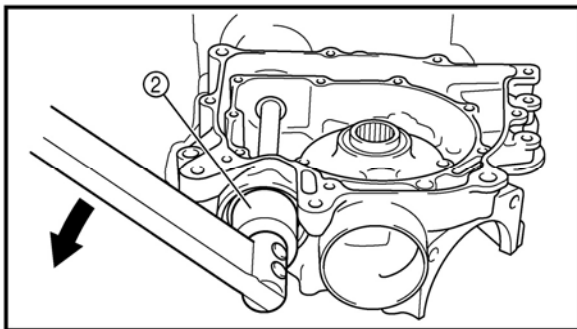

NOTE:

Attach the ring nut wrench ②.

CAUTION:

The middle driven shaft bearing retainer has left-handed threads. To tighten the retainer, turn it counterclockwise.

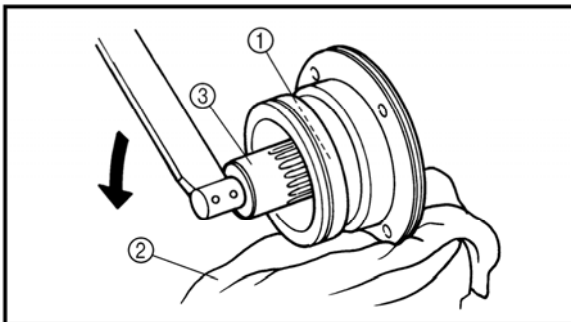

- bearing retainer ①

- a. Place a rag ② in the vise.
- b. Secure the bearing housing edge in the vise.
- c. Attach the bearing retainer wrench ③.
- d. Tighten the bearing retainer.

CAUTION:

The middle driven shaft bearing retainer has left-handed threads. To tighten the retainer, turn it counterclockwise.

Bearing retainer
110Nm

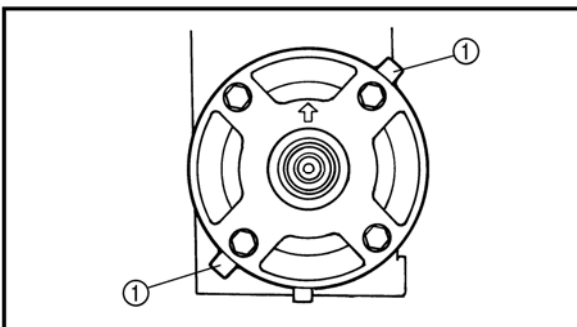

- shims ①
- bearing housing

NOTE:

Install the shims so that the tabs are positioned as shown in the illustration.

ENGINE

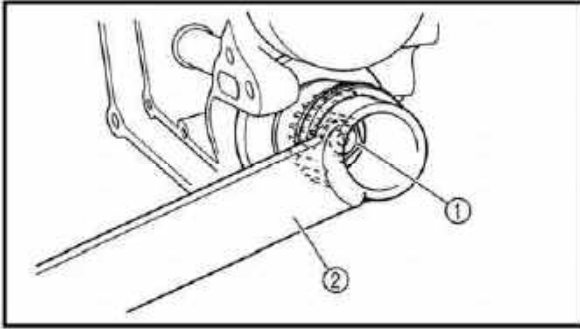

- drive shaft coupling
- washer
- nut ①(97Nm)

NOTE:

Use the coupling gear/middle shaft tool ② to hold the drive shaft coupling.

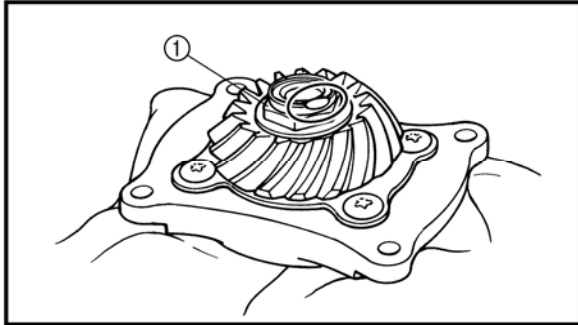

2). Installing the middle drive shaft

(1) Tighten:

- middle drive pinion gear nut ① (145Nm)

NOTE:

Secure the middle drive shaft in the vise with a clean rag.

(2) Lock the threads with a drift punch.

CHASSIS

MALFUNCTION INSPECTION

Appearance malfunction inspection		
No.	Phenomenon	Measure
1	Plastic cover damaged	1. Replace new plastic cover.
		2. Check whether installation supporter deformed, repairing or re-painting is needed before replacing new plastic cover.
		3. Re-paste decals and re-rivet warning labels.
2	Bumper damaged	1. Replace new bumper.
		2. Check whether installation supporter deformed or damaged, repairing or re-painting is needed before replacing new bumper.
3	Frame toe-board damaged	1. Replace new frame toe-board.
		2. Check whether gearbox and differential of front and rear axle damaged or leakage.
		3. Repaint the damaged paint layer
4	Front and rear carrier damaged	1. Replace new carrier.
		2. Check whether installation supporter deformed or damaged, repairing or re-painting is needed before replacing new bumper.
		3. Check plastic cover whether deformed or damaged, repairing deformed or damaged plastic cover.
5	Warning labels	Replace damaged and vague warning labels.
Brake system malfunction inspection		
No.	Phenomenon	Measure
1	Locked braking system	1. Check whether brake disc plates deformed.
		2. Check whether hydraulic cylinder of brake clamp locked or brake clamp assembly parts deformed.
2	Brake performance degressive	1. Check whether disc plates abrasion exceeded limits.
		2. Check whether brake shoe of clamp abrasion exceeded limits or polluted by friction material such as oil.
		3. Check whether the oil cup of brake fluid lack oil.
3	Grinding noises emerged from front brake or brake plate become red during drive due to superheat.	1. Check whether brake plate deformed.
		2. Check whether hydraulic cylinder of brake clamp locked or brake clamp assembly parts deformed.
4	Grinding noises emerged from rear brake or brake plate become red during drive	1. Check whether brake plate deformed.
		2. Check whether hydraulic cylinder of brake clamp locked or brake clamp assembly parts deformed.
		3. Check whether rear brake clamp parking institution running flexible or return accurately.

CHASSIS

5	Off tracking by braking at high-speed	1. Check whether front brake power deviation from left and right is within specified scope.
		2. Check whether front brake power degressive caused to rear wheel locked before front wheel in brake process.
		3. Check whether left and right absorber spring force deviation is exceeded specified value.
		4. Check whether front wheel and front wheel axle nut loosen or damaged.
		5. Check whether front wheel hub inner spline and front wheel axle outer spline worn or loosen.
		6. Check whether rubber cushion connected to front suspension rocker and frame damaged.
Other system malfunction inspection		
No.	Phenomenon	Measure
1	Steering wheel loosen, shift up and down	1. Check whether steering wheel clip loosen or damaged.
		2. Check whether steering column clip and clip seat loosen or damaged.
		3. Check whether steering column bottom end bearing damaged.
2	Front wheel steering clearance excessive	1. Check whether tie-rod and steering column locknut loosen or damaged, or steering knuckle and steering column locknut loosen or damaged.
		2. Check whether tie-rod two ball joint damaged.
3	Front wheel sway during drive	1. Check whether steering knuckle bearing damaged.
		2. Check whether king pin ball joint damaged.
		3. Check whether front wheel and axle locknut loosen or damaged.
		4. Check whether front wheel hub inner spline and front wheel axle outer spline worn or loosen.
		5. Check whether rubber cushion connected to front suspension rocker and frame damaged.
4	Rear wheel sway during drive	1. Check whether rear axle bearing damaged.
		2. Check whether sliding bearing connected to rear axle bearing housing and rocker loosen or damaged.
		3. Check whether rear wheel and axle locknut loosen or damaged.
		4. Check whether rear wheel hub inner spline and rear wheel axle outer spline worn or loosen.
		5. Check whether rubber cushion connected to rear suspension rocker and frame damaged.
5	Wheel hop during drive	1. Check whether wheel rim deformed.
		2. Check whether front and rear axles bent.
		3. Check whether tyre aging and deformed.

CHASSIS

No.	Phenomenon	Measure
6	Absorber become soft and comfortability depressed	1. Check whether over loading.
		2. Check whether absorber spring become soft.
		3. Check whether absorber lost of damping force in compression and prolongation.
7	Front and rear axles arise abnormal sound during drive	1. Check whether spline of front and rear axle intermediate propeller shaft damaged.
		2. Check whether front and rear axles splines damaged.
		3. Check whether gears of front gearbox and differential over worn.
		4. Check whether rear gearbox gears over worn.
		5. Check whether axle universal joint rubber boot damaged or universal joint damaged.
8	Fail to shift into four-wheel-drive or lock differential.	1. Check whether four wheel drive switch normal.
		2. Check whether power divider damaged.
		3. Check whether differential mechanical conversion agency locked or damaged.

CHASSIS

STEERING OPERATION SYSTEM

THE STEERING STEM PART

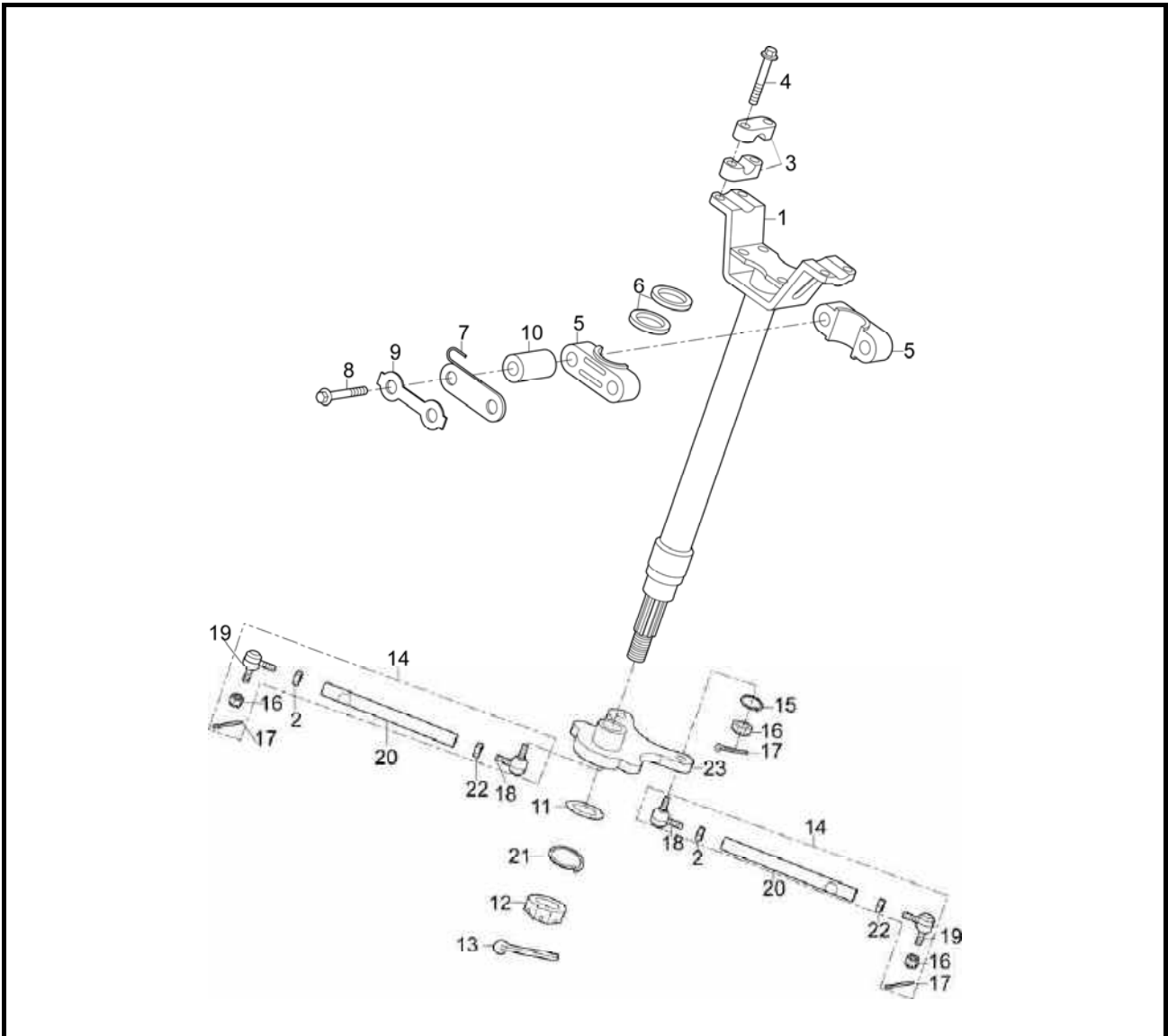

No.	Part Name	Qty	Remarks
	Removing the steering stem part		
1	Steering stem assy	1	
2	Hexagon nut (L)	2	
3	Upper fix bracket, steering stem	2	
4	Hexagon flange bolt M8×55	4	
5	Supporting block, steering stem	2	
6	Seal gasket, steering stem	2	
7	Stand bracket, steering stem	1	
8	Hexagon bolt M8×60	2	
9	Stop drive washer	1	

CHASSIS

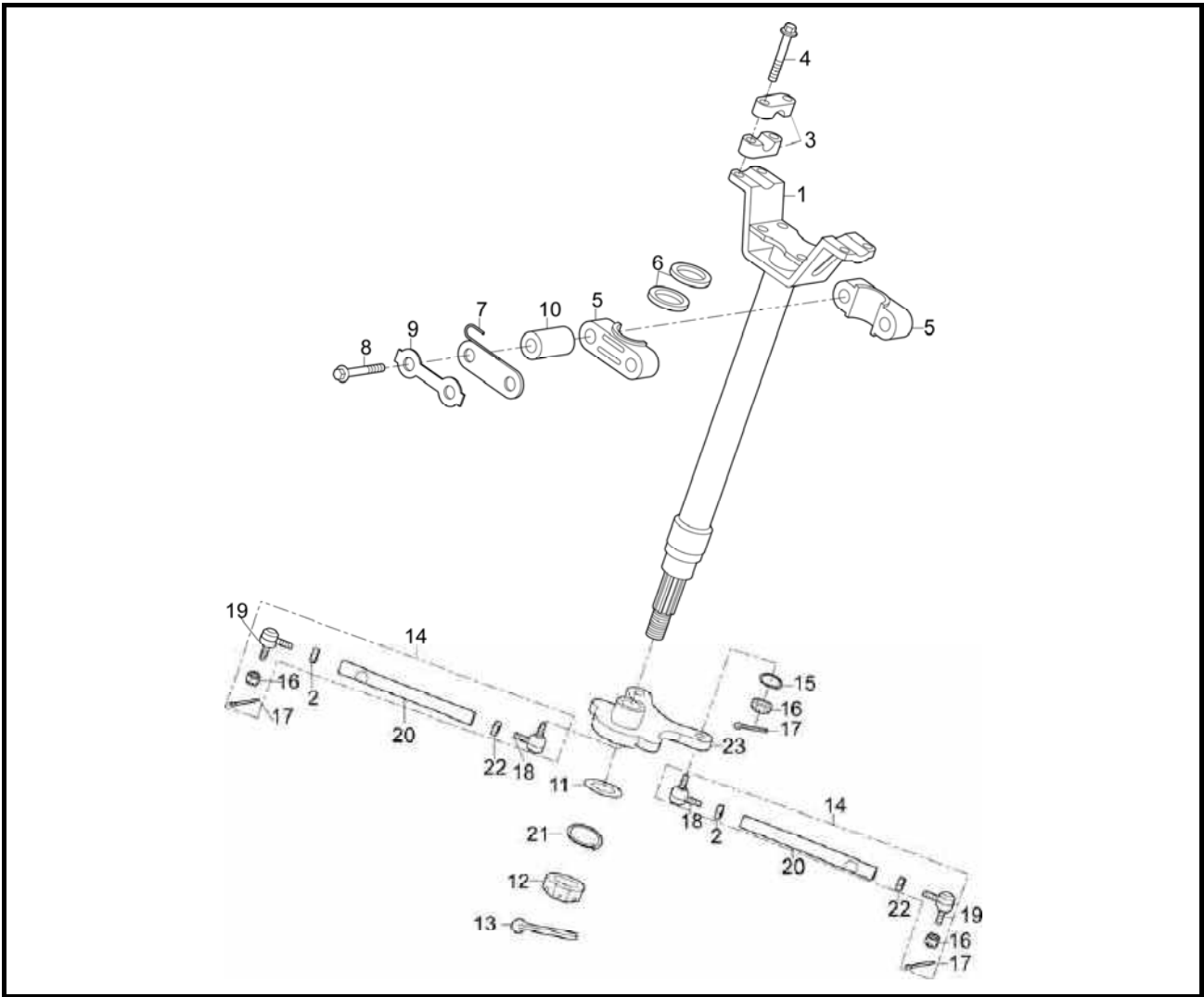

No.	Part Name	Qty	Remarks
10	Bush $\Phi 8 \times \Phi 14 \times 43.5$	2	
11	Washer $\Phi 15 \times \Phi 28 \times 2$	1	
12	Slotted nuts M14 \times 1.5	1	
13	Cotter pin 2.5 \times 40	1	
14	Shift straight rod assy	2	
15	Spring washer -10	2	
16	Hexagon bolt M10 \times 1.25	4	
17	Cotter pin 2.5 \times 40	4	
18	Straight rod in gimbal	2	
19	Straight rod out gimbal	2	
20	Shift straight rod	2	
21	Spring washer -14	1	
22	Hexagon nut	2	
23	Rocker, steering stem	1	

CHASSIS

THE STEERING HANDLE AND CABLE

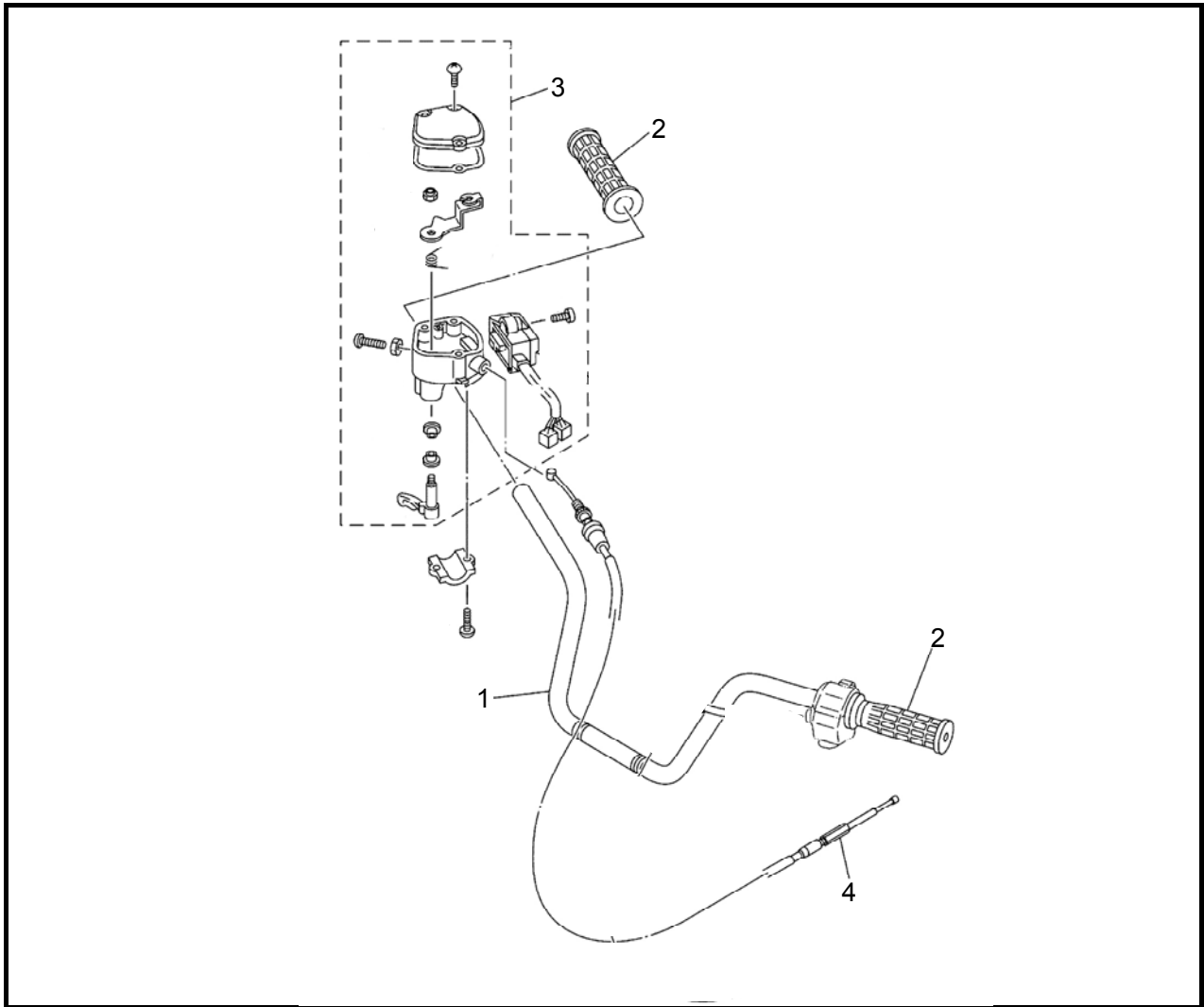

No.	Part Name	Qty	Remarks
	Removing steering handle and cable		
1	Handlebar pipe	1	
2	Handlebar rubber sleeve	2	
3	Accelerator assy.	1	
4	Accelerator cable	1	

CHASSIS

THE LEFT HANDLE BAR

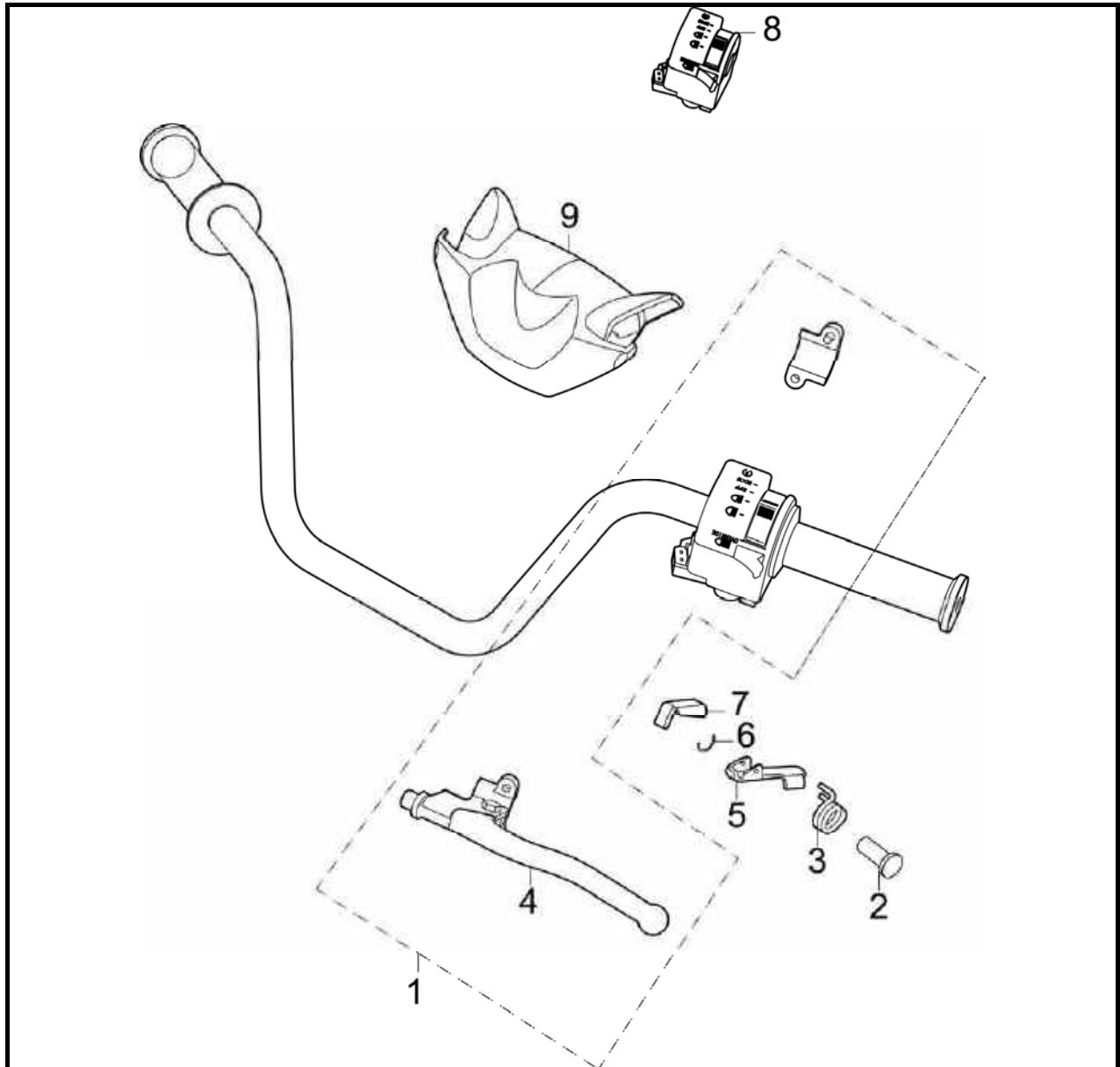

No.	Part Name	Qty	Remarks
	Removing left handle bar		
1	Lever assy, front brake	1	
2	Stop pin, stop brake	1	
3	Torsion spring ,stop brake	1	
4	Press plate, lever assy, front brake	1	
5	Front of stop clip, stop brake	1	
6	Stop pin block circle, stop brake	1	
7	Stop clip, stop brake	1	
8	Left switch assy.	1	
9	Handle shield	1	

CHASSIS

THE STEERING OPERATION SYSTEM

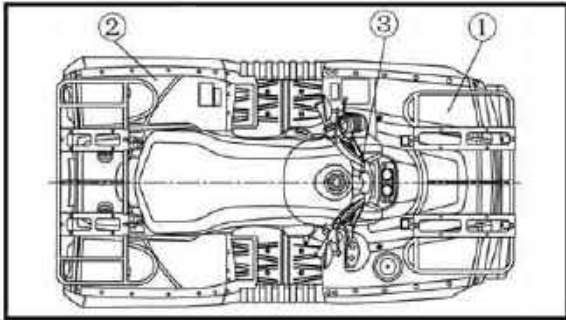

DIASSEMBLING THE PARTS OF STEERING BAR

1. Remove:

- front fender comp. ①
- rear fender comp. ②
- protector, handlebar ③

a. Takes down the front fender comp. ①

b. Takes down the rear fender comp. ②

c. Takes down the protector, handlebar. ③

2. Remove:

- all connecting wires
- cable, wind-proofed door
- cable, accelerograph
- cable, front brake
- cable, rear brake

3. Remove:

- bolt M8×30 ①
- holder handle ②
- holder handle seat ③

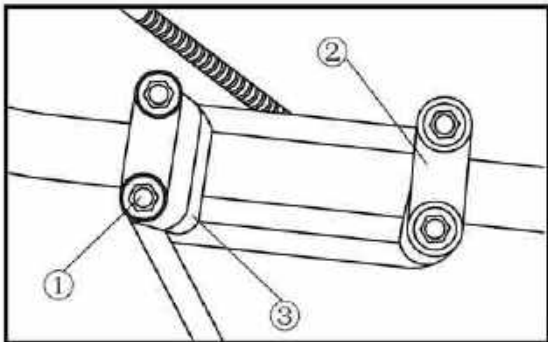

DIASSEMBLING THE PARTS OF STEERING COLUMN

1. Remove:

- bolt M8×60 ①
- washer lock ②
- bracket, steering lower ③

Bent/damaged → Replace

WARNING:

Always use new washer lock.

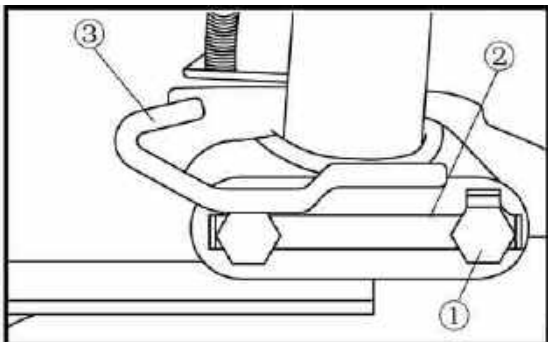

CHASSIS

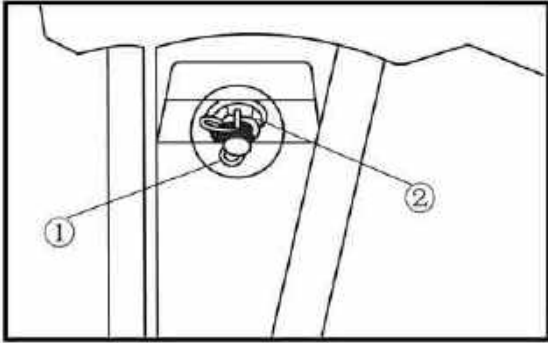

2. Remove:

- pin, cotter ①
- nut, self-locking ②

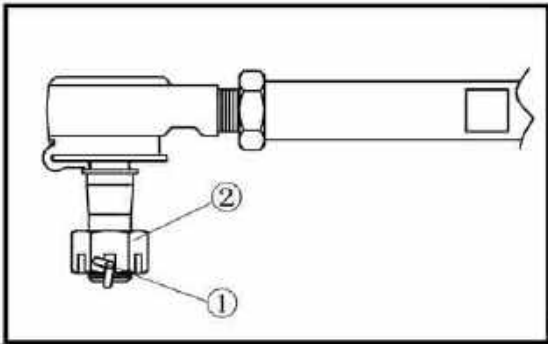

3. Remove:

- pin, cotter ①
- nut ②

CAUTION: _____
When removing the rod tie end and pin cotter from the column steering assembly and front seat assembly of front brake with common bearing tension tool and other pay attention to not damage the relevant parts.

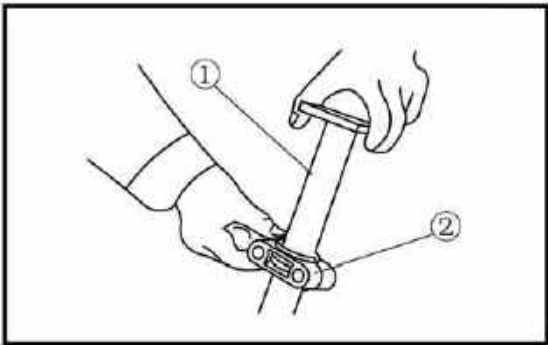

4. Remove:

- column, steering assembly ①
- plane bearing, steering ②

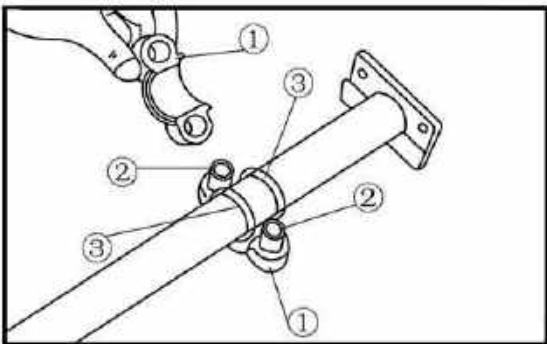

5. Remove:

- plane bearing, steering ①
- collar ②
- oil seal ③

CHASSIS

CHECKING THE STEERING OPERATION SYSTEM

1. Check:

- handle bar

Bent/damaged → Replace

The handle bar to rotate whether nimble, do not have stagnation → Adjust

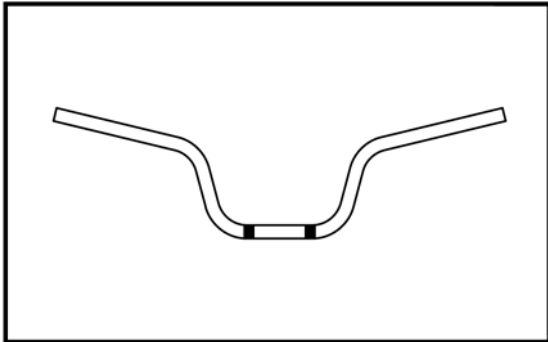

2. Check:

- column, steering assembly

Bent/damaged → Replace

WARNING: _____
In order to avoid decreasing the performance of column steering assembly, if it is bent do not straighten it forcefully.

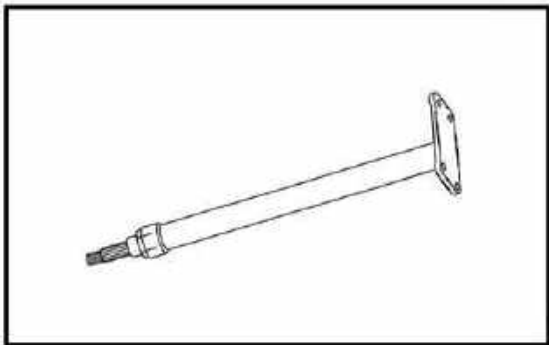

3. Check:

- plane bearing, steering ①

- oil seal ②

Worn/damaged → Replace

NOTE: _____
Apply lithium-soap-based grease to the oil seal and plane bearing steering.

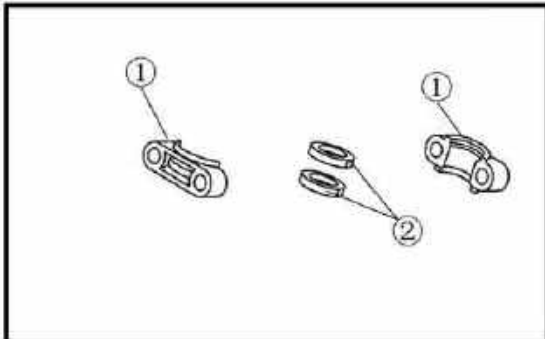

4. Check:

- Rod, tie ①

Bent/damaged → Replace

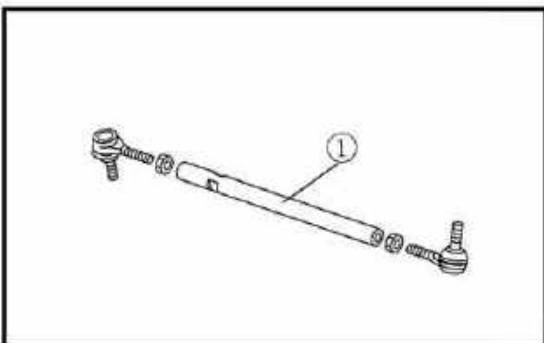

CHASSIS

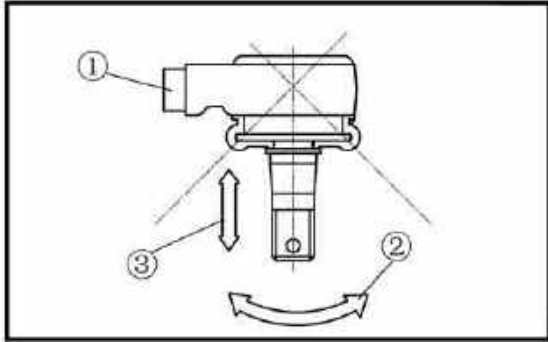

5. Correcting:

- Straight rod gimbal ①
- turning ②
- rocky ledge ③

Wear/damaged → Replace

Free play → Replace the straight rod gimbal.

Turns roughly → Replace the straight rod gimbal.

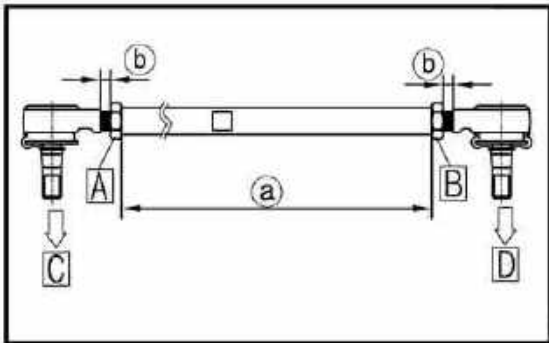

6. Adjustment:

- Shift straight rod assembly

Adjustment steps of shift straight rod assembly length.

a. Loosen the connecting nut A、B;

b. Adjusting the assembly length of rod tie by rotating the rod tie.

Attached: straight rod assembly length^a: 325mm.

A Right-hand thread

B Left-hand thread

Connect C position to the column steering assembly.

Connect D position to the front steering knuckle assembly.

CAUTION: _____

The connection nut A、B can be tighten up only when the revealed thread length b of two ends of rod tie are the same.

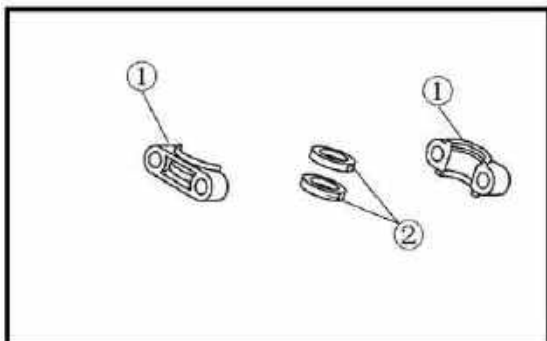

INSTALLING THE STEERING OPERATION SYSTEM

The reversal steps of “disassembling” steps is “installing” steps, pay attention to the following points during installment.

1. Install:

When installing column steering assembly, lubricate the plane bearing steering ① and oil seal ②

CHASSIS

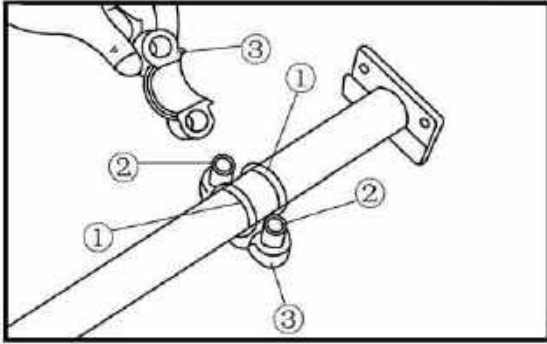

2. Install:
- oil seal ①
 - collar ②
 - plane bearing, steering ③

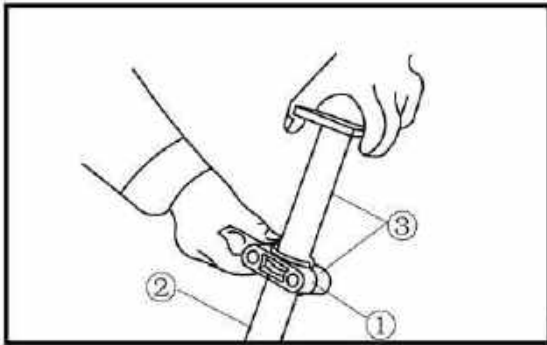

3. Install:
- When installing the plane bearing steering ① and column steering assembly ② take them as a unit ③.

WARNING: _____
In order to ensure the correct circuit of brake cable and wire, never damage and wind the cables and wires.

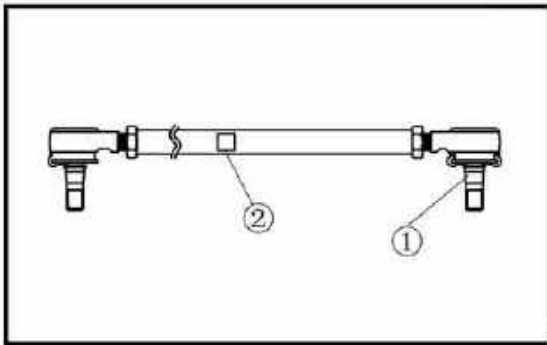

4. Install:
- rod tie (L&R) ②

CAUTION: _____
Make sure that the straight rod gimbal ① at side of scraped marking contents with the front seat assembly of front brake.

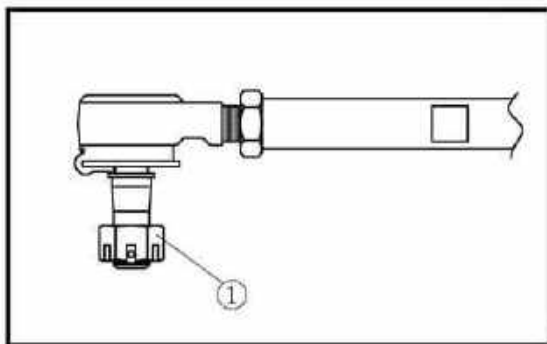

5. Tighting:
- nut ①
- Tighten up the nut ① of straight rod gimbal.

CHASSIS

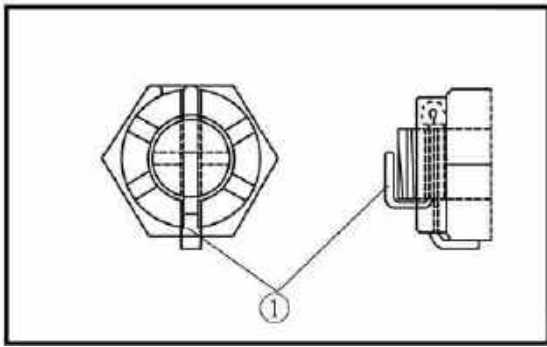

6. Mounting:
- pin, cotter ①

CAUTION: _____
Don't loosen the nut after the torque is fixed. If the nut recess is not correspondance with pin cotter, cotter hole on the double-screw bolt, tighten the nut to align them.

WARNING: _____
Always use new pin cotter.

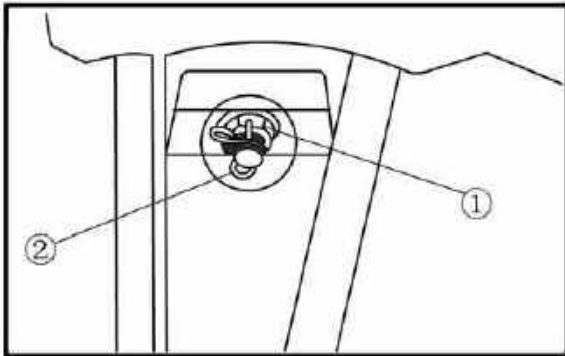

7. Tighting:
- nut, self-locking ①
 - pin, cotter ②

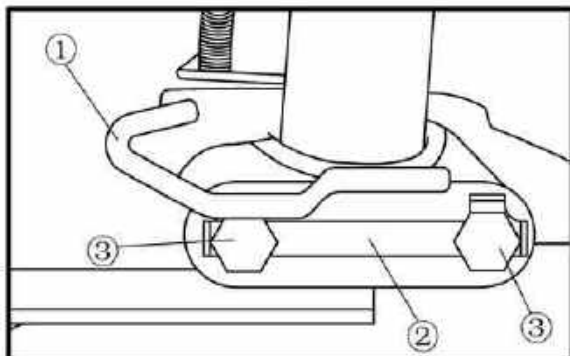

8. Install:
- bracket, steering lower ①
 - washer lock ②
 - bolt M8×60 ③

WARNING: _____
Always use new washer lock.

9. Bent showing supporting lug of washer lock to lock tightly the bolt.

CHASSIS

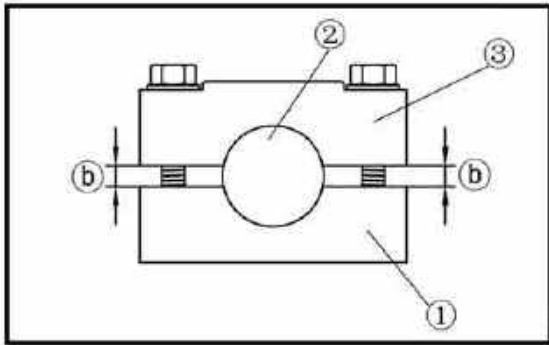

INSTALLING THE STEERING HANDLE

1. Install:

- lower holding seat ①
- handle bar ②
- upper holding seat ③

WARNING: _____

When tightening the bolt of holding seat, make ensure the even of clearance ⑥ .

2. Install:

- throttle grip unit

CAUTION: _____

The projection of throttle grip must correspond to the sunken part on the right lever seat when installation.

WARNING: _____

Correct installation of cable and wire is very necessary for ensuring the safety operation of vehicle ⑥ .

3. Adjustment:

Adjusting the free clearance of brake cable and adjusting of free clearance about left handle lever and rear brake pedal.

4. Adjusting the toe-in of front wheel.

5. Mounting front fender comp, rear fender comp, protector handlebar.

BRAKE SYSTEM

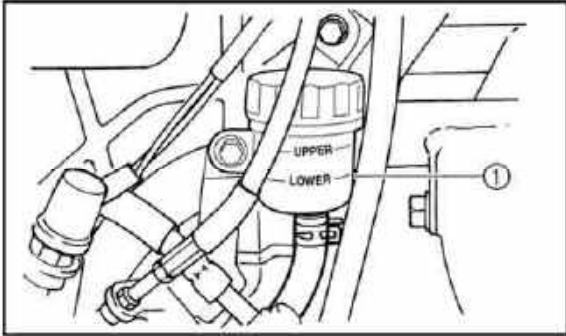

PREPARATION FOR CHECKING BEFORE THE MAINTENANCE OF THE BRAKE SYSTEM.

Brake system is crucial to the life safety of the operator and therefore must be periodically inspected and maintained.

This vehicle uses the single return route hydraulic pressure disc brake system. Please follow the tips of inspection as below.

①. To check the amount of liquid in the oil cup. If it is lower than the minimum mark, refill the box with the same type of fluid as was recommended by the manufacturer, to ensure to fluid level is higher than the minimum mark.

②. The brake lever should be kept between 3mm-5mm, Otherwise, please adjust the screw to meet required travel distance.

1. Inspect the brake pedal does maintain the certain counter-tension

When checks disk brake plate, the saved liquid in the oil cup will pour automatically into the pressure pipe and the liquid level along with it to reduce, the periodic inspection the disk brake plate liquid volume will be an important project.

Must use DOT4 Brake Fluid

2.

- rear disk brake plate ①
- thickness ②

Periodical inspection of the wear condition of rear disk brake plate is also necessary. Disk brake plate must be replaced depending on its wear condition.

3. Disk brake plate uses hydraulic pressure of the brake fluid. Therefore, fuel pipe must be periodically inspected and replaced.

Inspection method: If the oil tubing has the aging, crack or distortion, must replace the oil tubing.

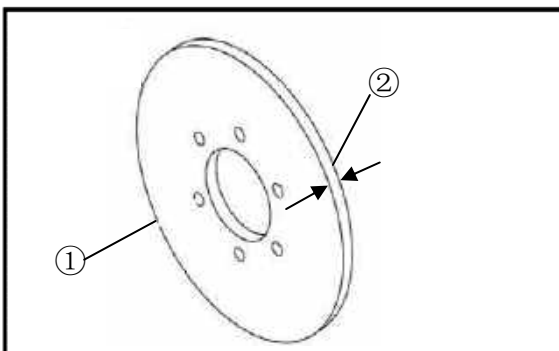

CHASSIS

BRAKE SYSTEM

DISK BRAKE COMPONENTS

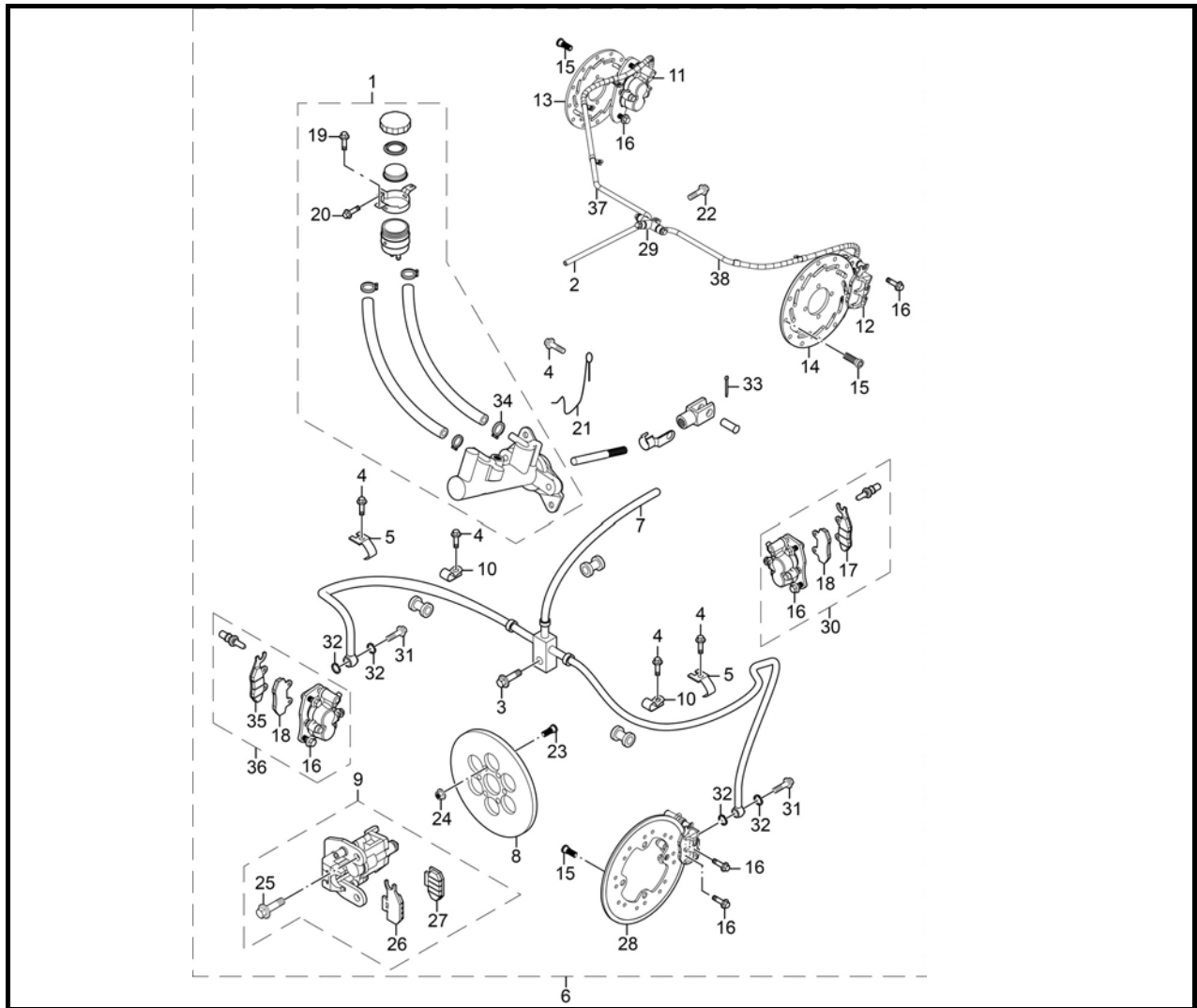

No.	Part Name	Qty	Remarks
	Removing brake components		
1	Rear brake pump	1	
2	Rear brake hose	1	
3	Hexagon flange bolt M6×25	1	
4	Hexagon flange bolt M6×12	5	
5	Oil pipe clip, front disc brake	2	
6	Disc brake assy	1	
7	Front brake hose	1	
8	Parking brake plate	1	
9	Parking brake assy	1	
10	Clip, oil pipe	3	

CHASSIS

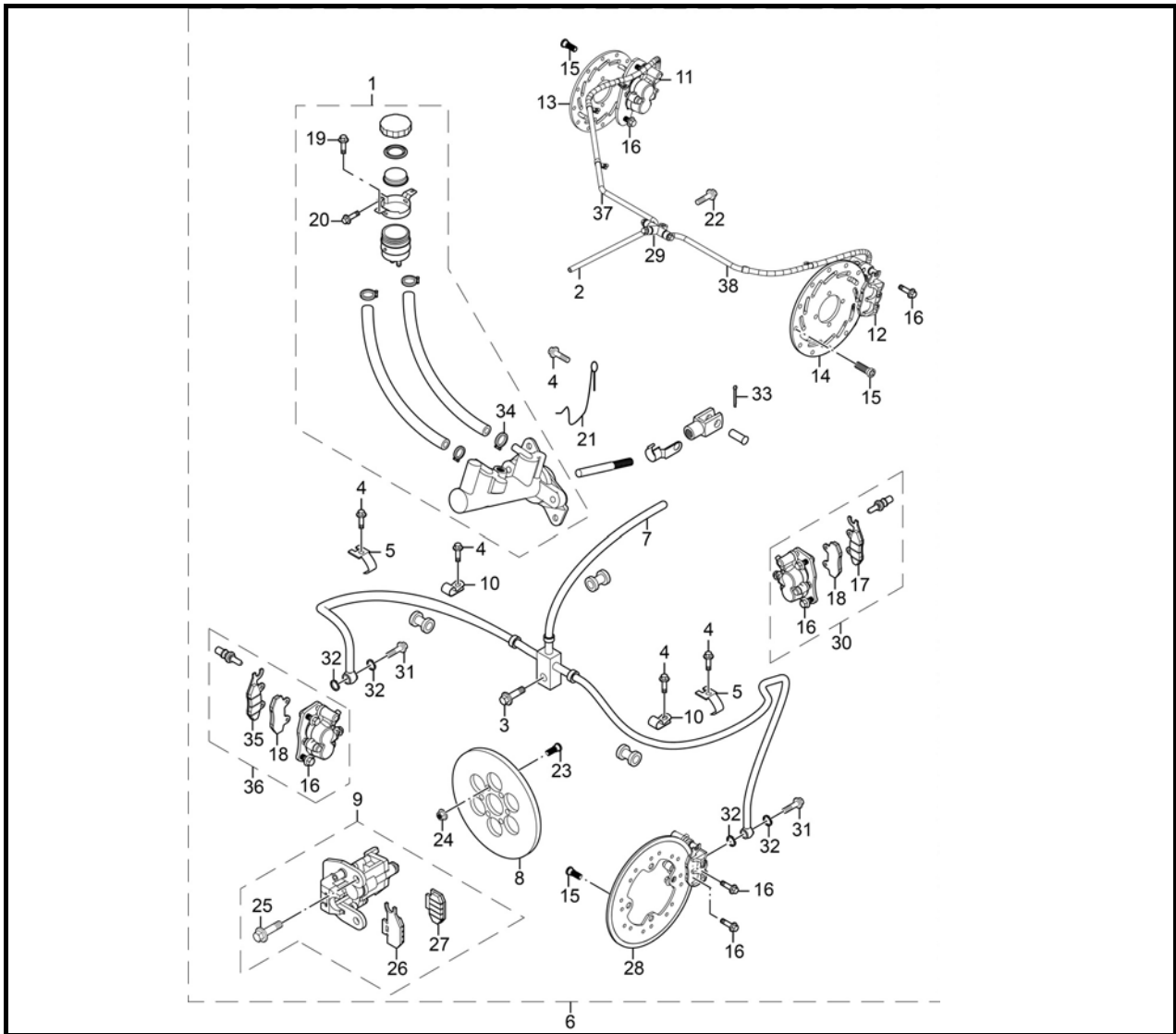

No.	Part Name	Qty	Remarks
11	Rear right brake caliper	1	
12	Rear left brake caliper	1	
13	Rear right brake plate	1	
14	Rear left brake plate	1	
15	Hexagon step bolt M8x20	16	
16	Bolt M10x1.25x22	8	
17	Outer brake pad assy(front & left)	2	
18	Inner brake pad assy	4	
19	Hexagon flange bolt M6x16	3	
20	Hexagon flange bolt M6x20	1	
21	Oil pipe orientated spring	1	
22	Hexagon flange bolt M6x30	1	
23	Hexagon step zylinderschraube M6x14-Φ7x15	6	

CHASSIS

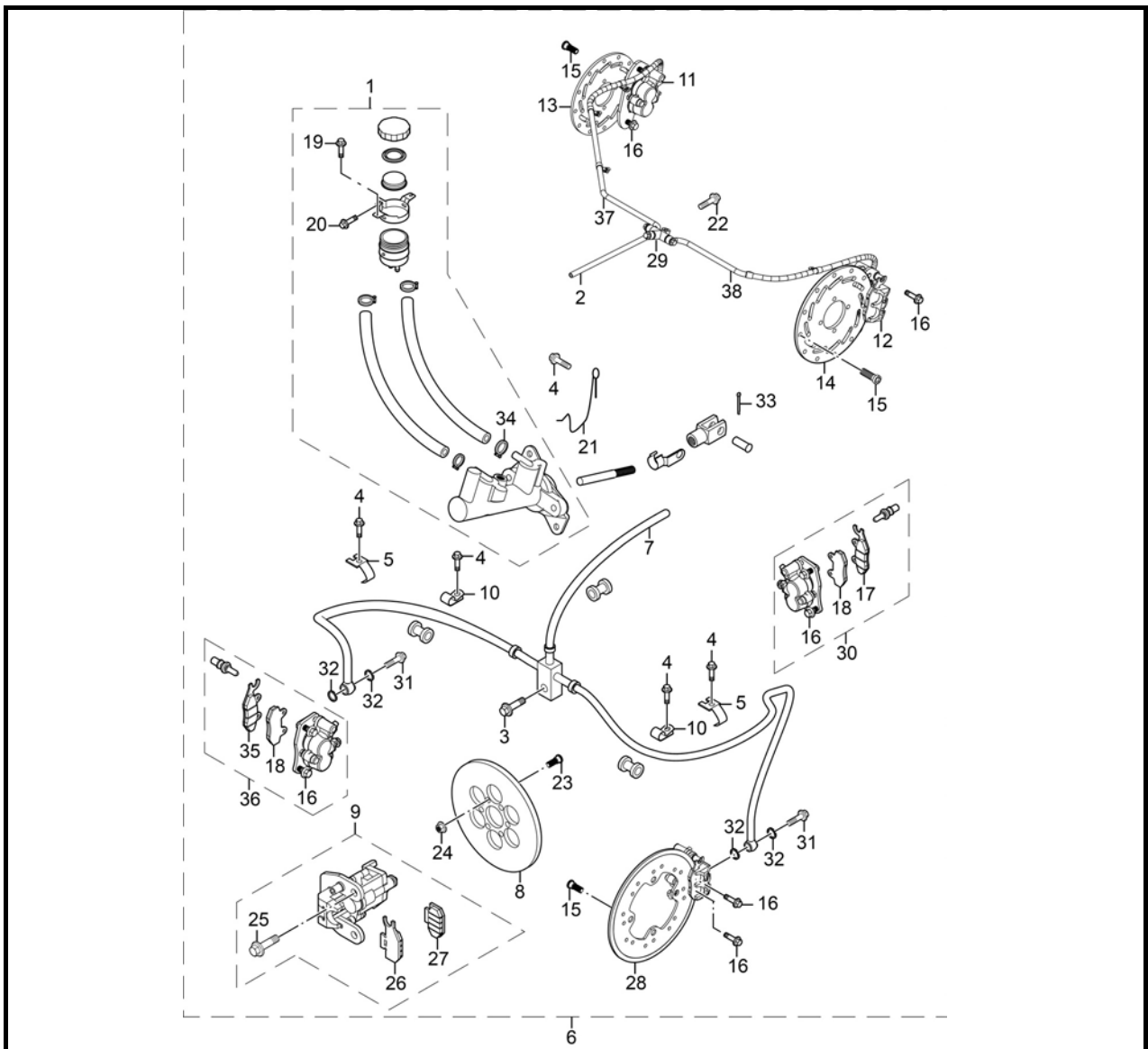

No.	Part Name	Qty	Remarks
24	Hexagon flange self-lock nuts M6	6	
25	Hexagon bolt M10×1.25×55	2	
26	Outer brake pad assy(parking caliper)	1	
27	Inner brake pad assy(parking caliper)	1	
28	Front brake pad	2	
29	Cooper seal	1	
30	Front left brake caliper	1	
31	Strainer bolt	4	
32	Cooper seal	8	
33	Split pin	1	
34	Oil pipe hoop	4	
35	Outer brake pad assy (front & right)	2	

CHASSIS

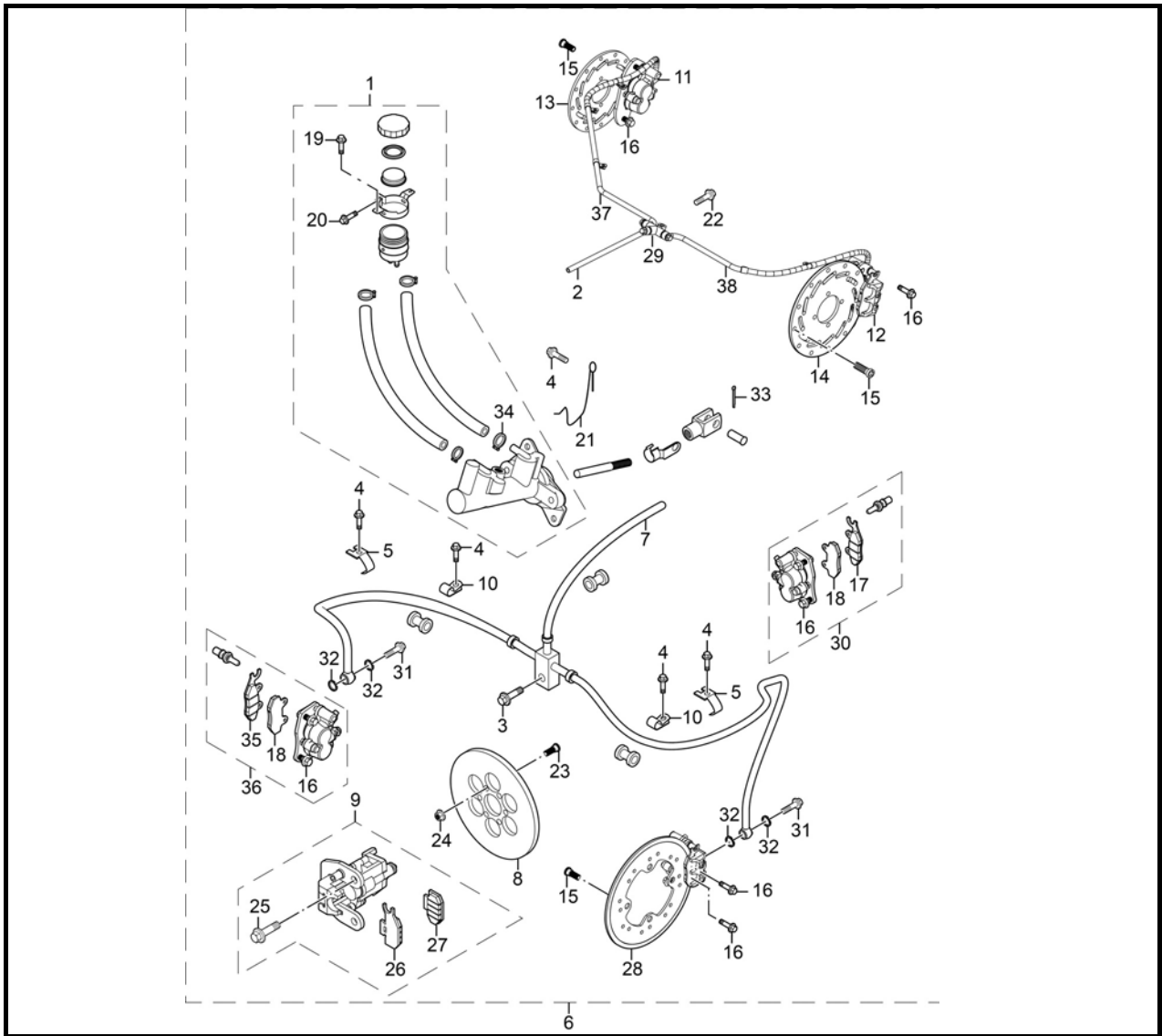

No.	Part Name	Qty	Remarks
36	Front right brake caliper	1	
37	Rear right brake hose	1	
38	Rear left brake hose	1	

CHASSIS

FRONT BRAKE CALIPER

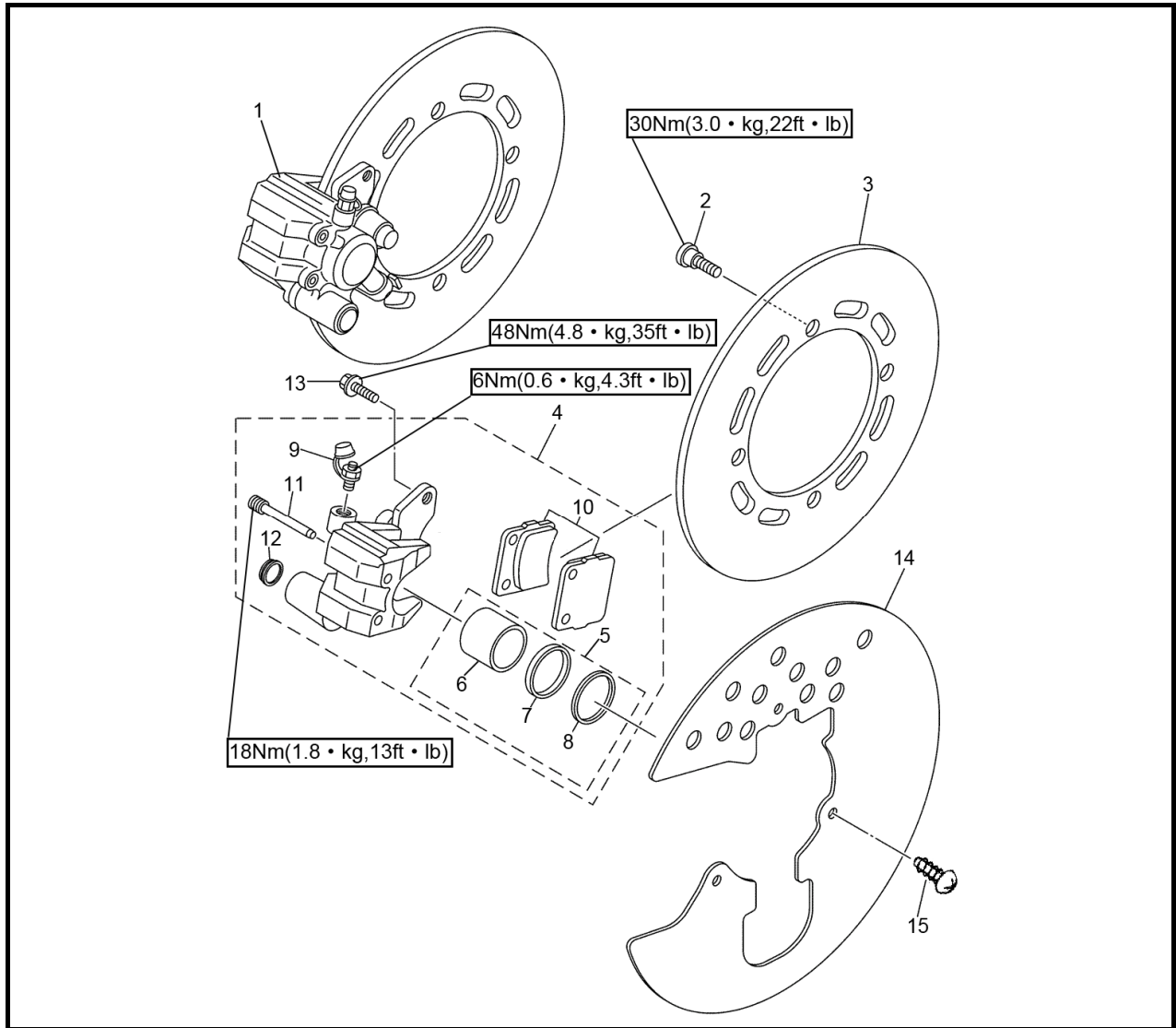

No.	Part Name	Qty	Remarks
	Removing front brake caliper (L&R)		
1	Brake caliper assembly	2	
2	Bolt M8×20	8	
3	Brake disc	2	
4	Brake Caliper assembly	2	
5	Brake Caliper, piston assembly	2	
6	Brake caliper piston	2	
7	Caliper piston seal	2	
8	Dust seal	2	
9	Bleed screw	2	
10	brake, pad	2	

CHASSIS

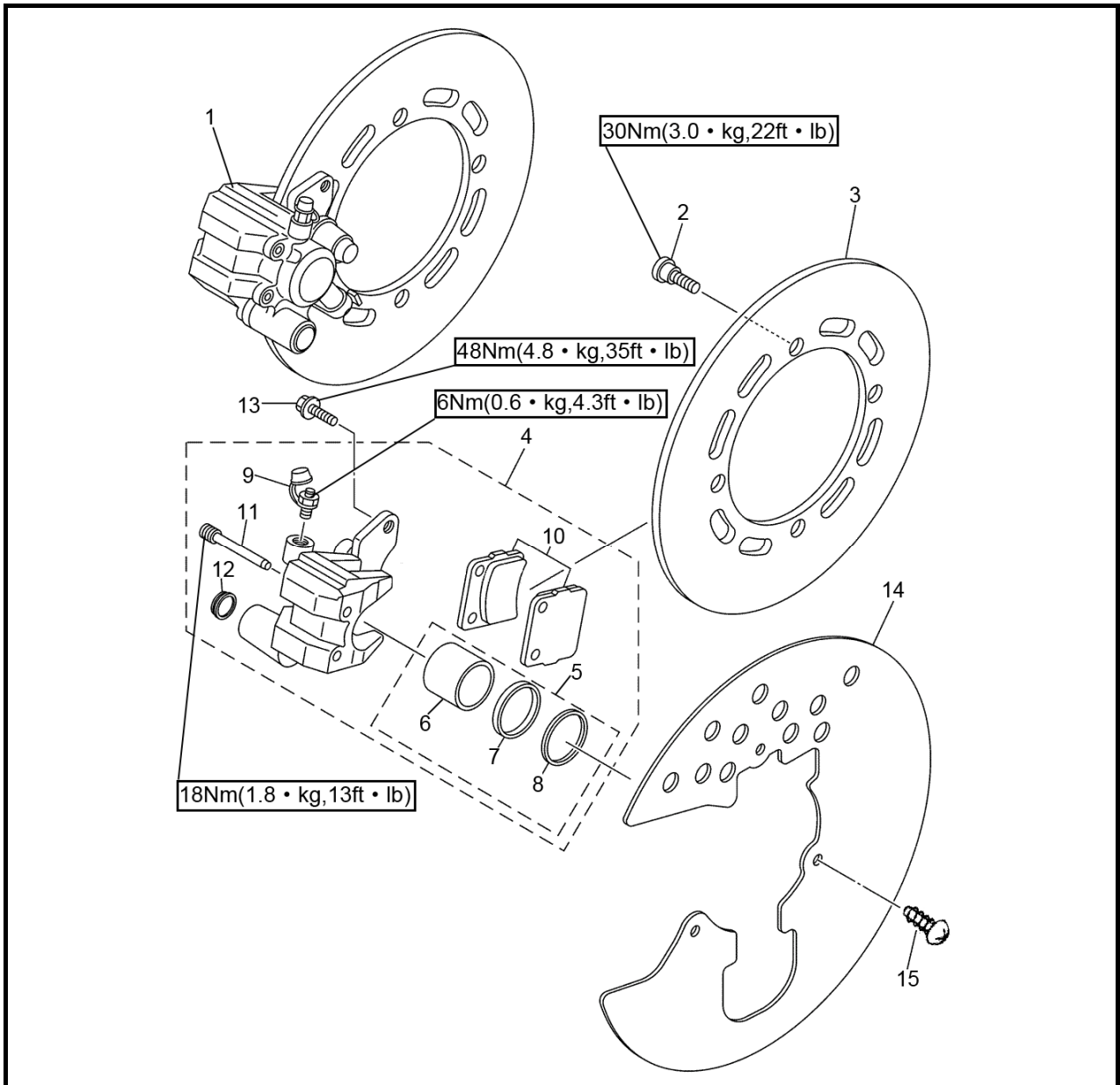

No.	Part Name	Qty	Remarks
11	Brake pad holding bolt	4	
12	plug	2	
13	Blot, flange M8×14	4	
14	Brake disc guard	2	
15	Bolt M6×12	6	

CHASSIS

CHECKING THE FRONT BRAKE DISC

1. Check:

- brake disc

Galling/damage → Replace.

2. Measure:

- brake disc deflection

Out of specification → Check the wheel runout.

If wheel runout is within the limits, replace the brake disc.

Brake disc maximum deflection

0.10 mm (0.004 in)

- brake disc thickness ①

- wheel hub ②

- wheel tyre ③

Out of specification → Replace.

Brake disc minimum thickness

3.0 mm (0.12 in)

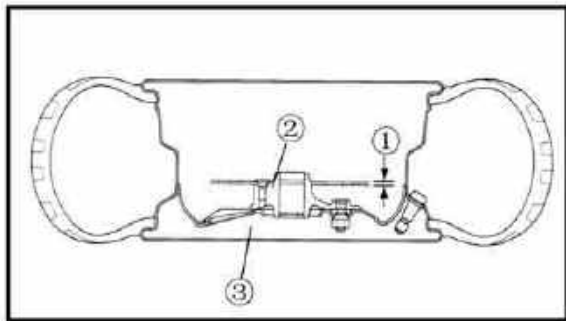

NOTE: _____

Apply the locking agent to the 30Nm bolt with screw down.

CHASSIS

REPLACING THE FRONT BRAKE PADS

NOTE:

It is not necessary to disassemble the brake caliper and brake hose to replace the brake pads.

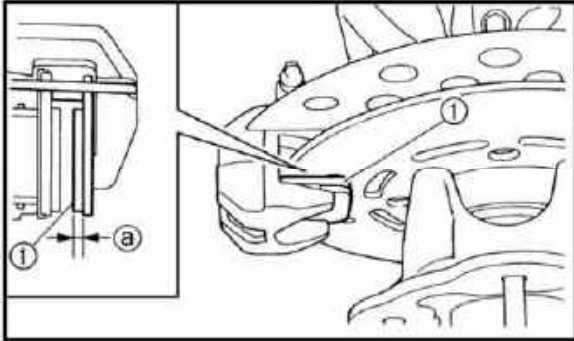

1. Check:

- brake pad ①
Damage/wear → Replace

2. Measure:

- brake pad thickness ①
Out of specification → Replace the brake pads as a set.

Brake pad wear limit
1.0 mm (0.04 in)

3. Install:

- brake pads

NOTE:

Always install new brake pads and brake pad spring as a set.

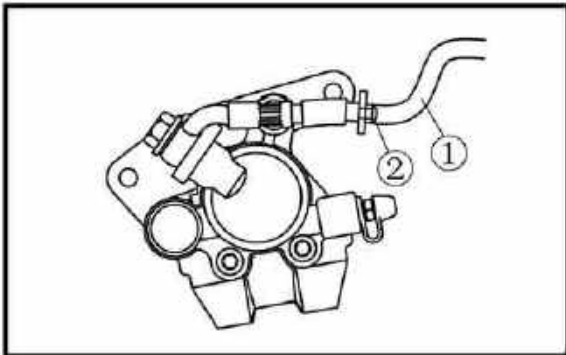

- Connect a suitable hose ① tightly to the brake caliper bleed nozzle ②. Put the other end of this hose into an open container.
- Loosen the brake caliper bleed screw and, using a finger, push the caliper piston into the brake caliper.
- Tighten the brake caliper bleed screw.

Brake caliper bleed screw
6 Nm (0.6 m · kg, 4.3 ft · lb)

- Install the retaining bolts and brake caliper.

Brake pad holding bolt
18 Nm (1.8 m · kg, 13 ft · lb)
Blot, flange
48 Nm (4.8 m · kg, 35 ft · lb)

CHASSIS

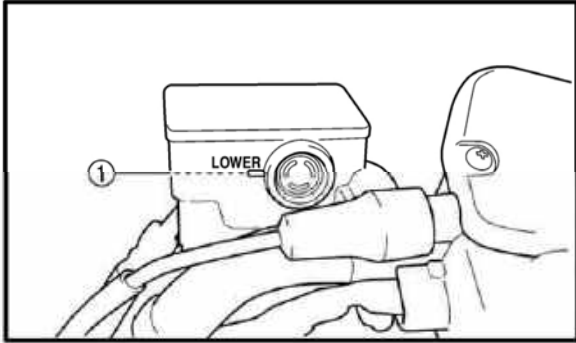

4. Check:

- brake fluid level
- minimum level mark ①

the brake fluid box level on the right handlebar.

Should the fluid level falls under the minimum mark, please refill the box with the same type of fluid as was recommended by the manufacturer to ensure the fluid level is higher than the minimum mark.

Must use DOT4 Brake Fluid

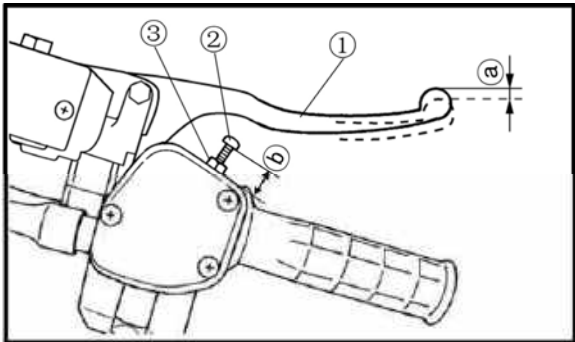

5. Check:

- brake lever ①
- adjusting screw ②
- locknut ③
- brake lever free play (a)
- no more than 10mm-15mm (b)

the front brake lever should have a free play of zero mm (zero in) at the lever end. If not, have a dealer check the brake system((a)).

travel distance of the front brake lever should be kept between 10mm-15mm. Otherwise, please adjust the screw to meet required travel distance((b)).

the elasticity of the brake lever.

CHASSIS

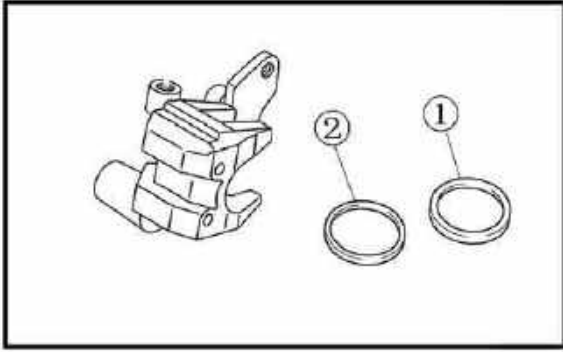

DISASSEMBLING THE FRONT BRAKE CALIPERS

1. Remove:

- brake caliper pistons
- dust seals ①
- caliper piston seals ②

a. Blow compressed air into the hose joint opening to force out the caliper piston from the brake caliper body.

WARNING:

- *Never try to pry out a caliper piston.*
- *Cover the caliper piston with a rag. Be careful not to get injured when the piston is expelled from the caliper cylinder.*

b. Remove the dust seals and caliper piston seals.

WARNING:

All internal brake components should be cleaned in new brake fluid only. Do not use solvents as they will cause seals to swell and distort.

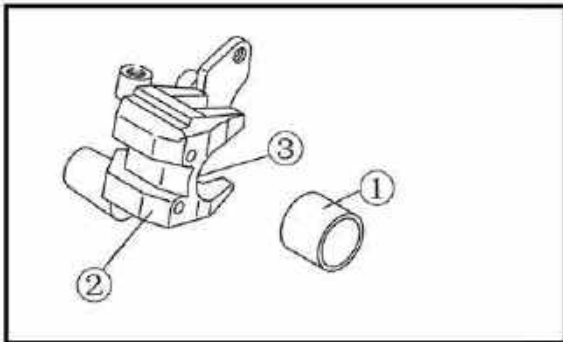

2. Check:

- brake caliper pistons ①
Scratches/rust/wear → Replace the brake caliper assembly.
- brake caliper cylinders ②
Wear/scratches → Replace the brake caliper assembly.
- brake caliper body ③
Cracks/damage → Replace.
- brake fluid delivery passage (brake caliper body)
Blockage → Blow out with compressed air.

WARNING:

Replace the caliper piston seals and dust seals whenever the brake caliper is disassembled.

CHASSIS

ASSEMBLING THE FRONT BRAKE CALIPERS

WARNING:

- All internal brake components should be cleaned and lubricated with new brake fluid only before installation.

Must use DOT4 Brake Fluid

- Replace the caliper piston seals and dust seal whenever a brake caliper is disassembled.

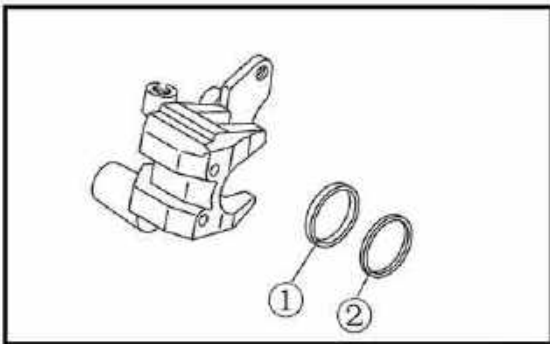

1. Install:
 - caliper piston seals ①
 - dust seals ②

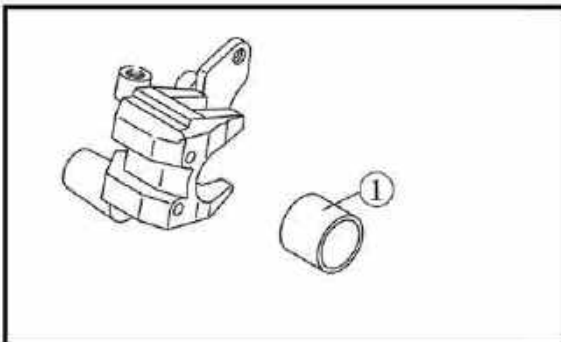

2. Install:
 - brake caliper pistons ①

INSTALLING THE FRONT BRAKE CALIPERS

The following procedure applies to both of the front brake calipers.

1. Install:
 - brake caliper assembly
 - bolt flange

48Nm (4.8m · kg, 35 ft · lb)

- brake hose ①
- copper washers ②
- union bolt ③

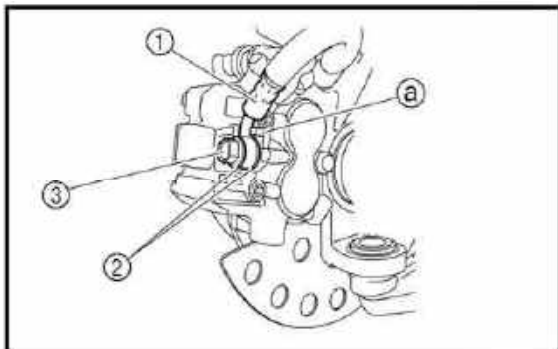

CHASSIS

NOTE: _____

When installing the brake hose on the brake caliper, make sure that the brake pipe touches the projection a on the brake caliper.

WARNING: _____

Proper brake hose routing is essential to insure safe vehicle operation.

2. Fill:

- brake reservoir

Must use DOT4 Brake Fluid

NOTE: _____

Brake fluid may damage painted surfaces or plastic parts. Always clean up spilled brake fluid immediately.

3. Air bleed:

- brake system

4. Check:

- brake fluid level

Brake fluid level is below the "LOWER" level line

→ Add the recommended brake fluid to the proper level.

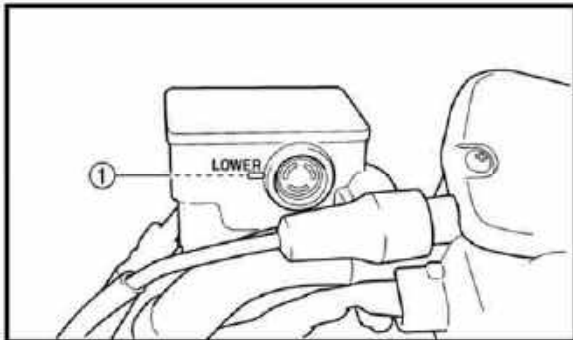

CHASSIS

REAR BRAKE CALIPER

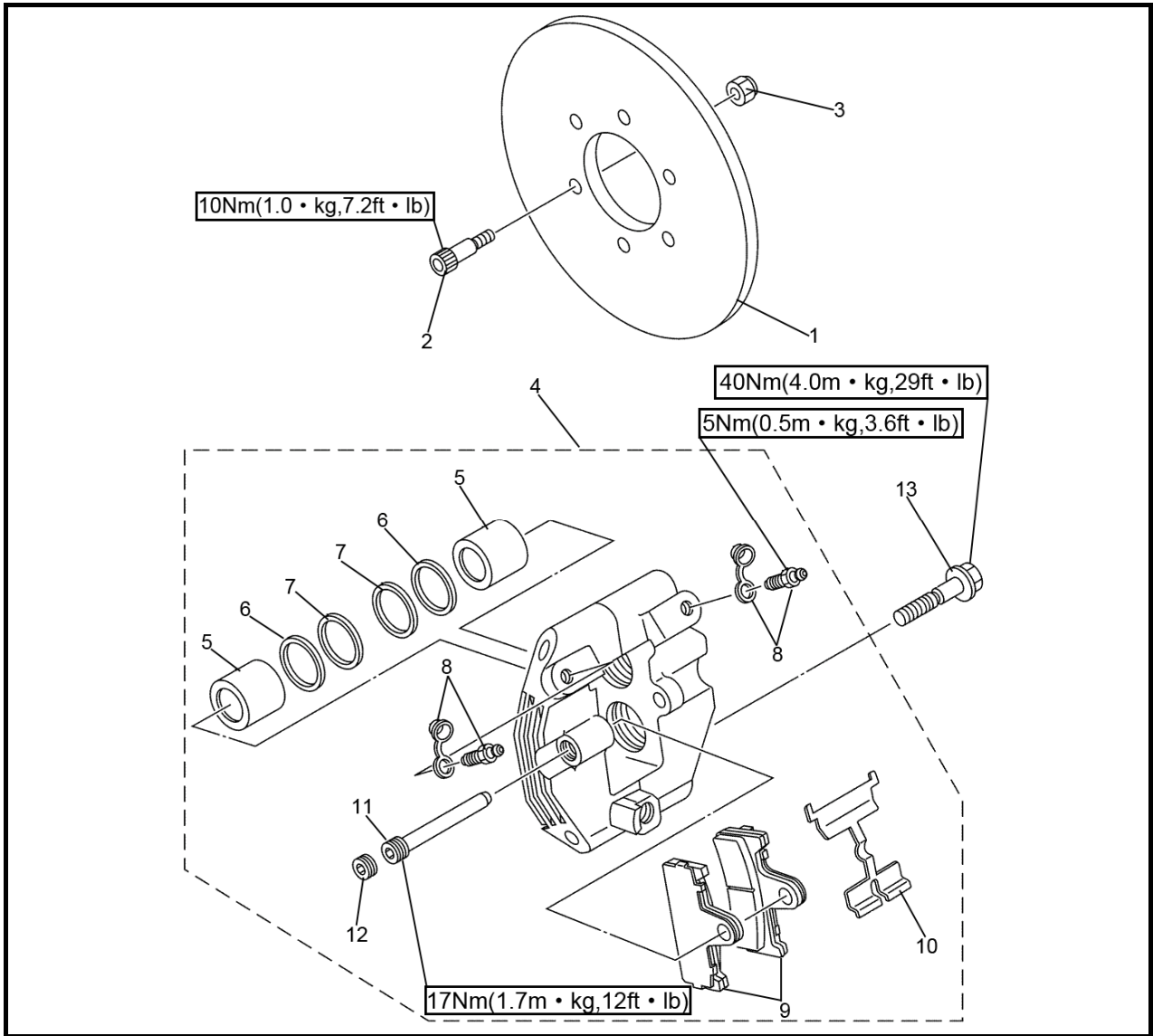

No.	Part Name	Qty	Remarks
Removing rear brake caliper			
1	Brake disc	1	
2	Bolt M6×30	6	
3	Nut M6	6	
4	Brake caliper assembly	1	
5	Brake caliper piston	2	
6	Caliper piston seal	2	
7	Dust seal	2	
8	Bleed screw	2	
9	brake, pad	1	
10	Pad, spring	1	

CHASSIS

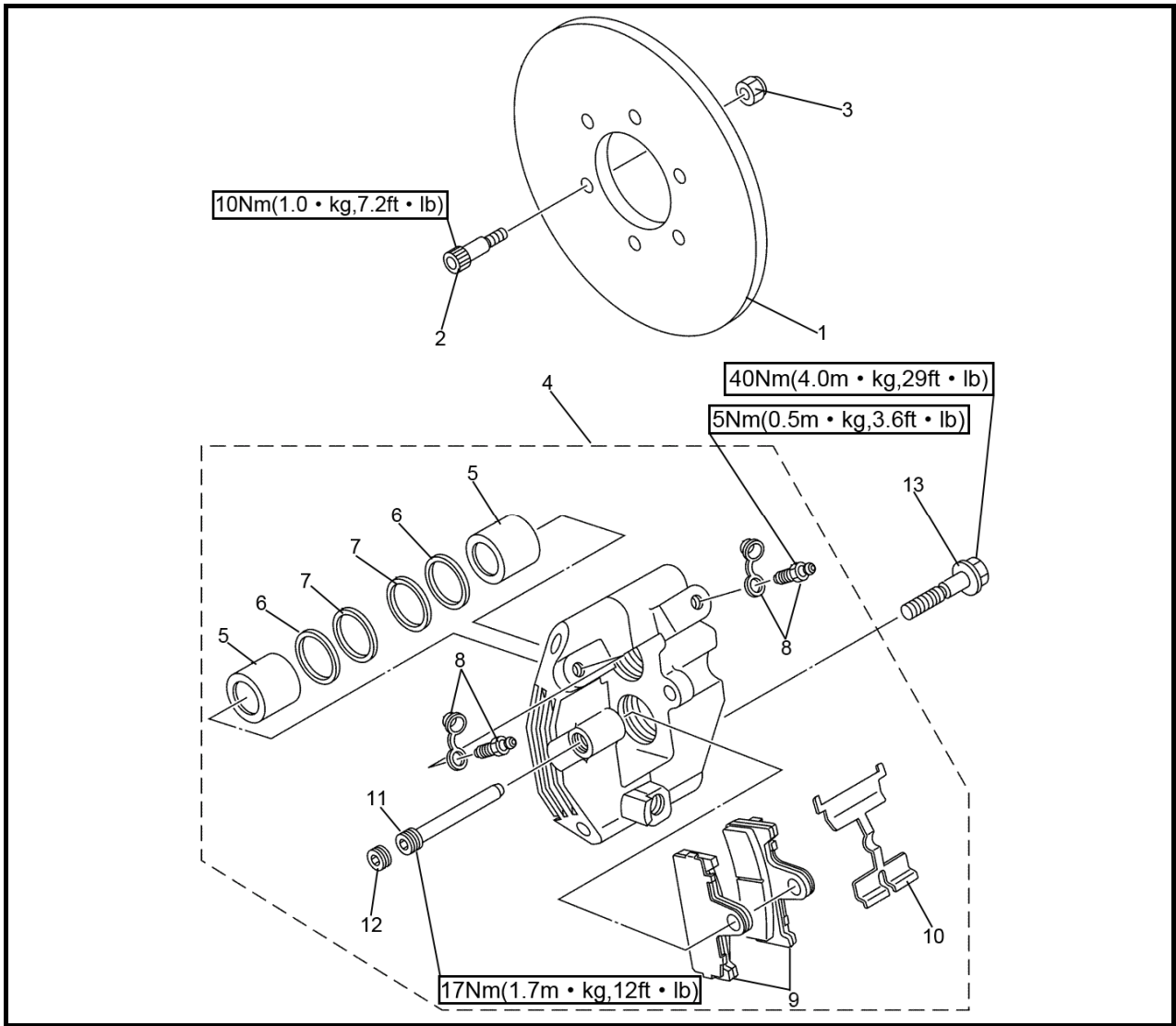

No.	Part Name	Qty	Remarks
11	Brake pad holding bolt	1	
12	Bolt	1	
13	Blot, flange M10×1.25×30	2	

CHASSIS

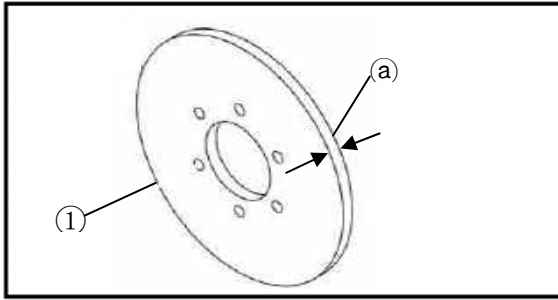

CHECKING THE REAR BRAKE DISC

1. Check:

- brake disc ①

Galling/damage → Replace.

2. Measure:

- brake disc deflection

Out of specification → Replace.

Brake disc maximum deflection
0.10 mm (0.004 in)

- brake disc thickness ②

Out of specification → Replace.

Brake disc minimum thickness
8 mm (0.31 in)

CHASSIS

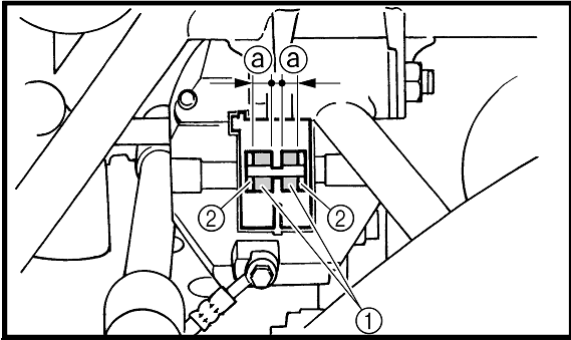

REPLACING THE REAR BRAKE PADS

1. Check:

- brake pad ①
- brake pad plate ②

Damage/wear → Replace

2. Measure:

- brake pad thickness ③

Out of specification → Replace the brake pads as a set.

Brake pad wear limit

1.0 mm (0.04 in)

3. Install:

- brake pads
- brake pad spring

NOTE:

Always install new brake pads, new brake pad shims, new insulators, and a new brake pad spring as a set.

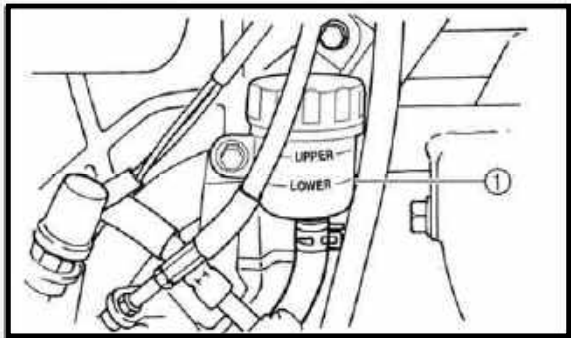

4. Check:

- brake fluid level
- minimum level mark ①

Should the fluid level falls under the minimum mark, please refill the box with the same type of fluid as was recommended by the manufacturer to ensure the fluid level is higher than the minimum mark.

Must use DOT4 Brake Fluid

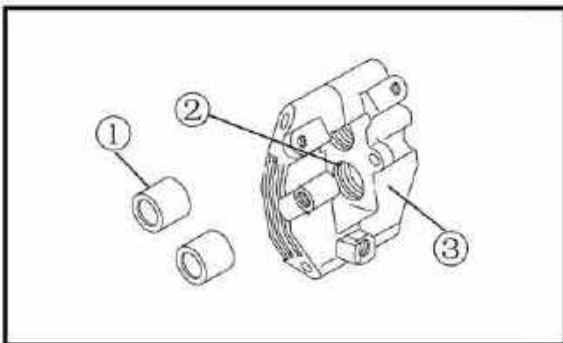
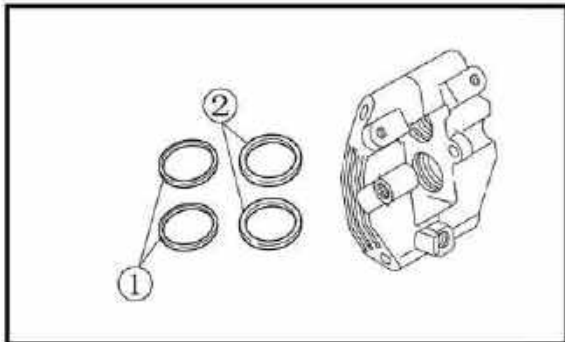
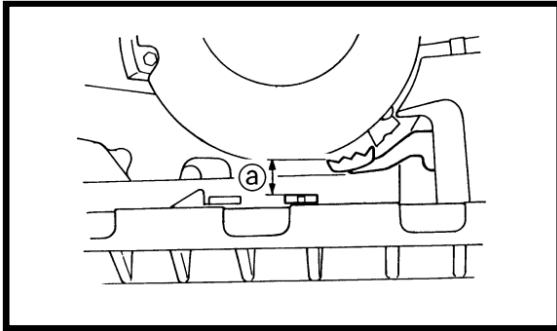

5. Check:

- brake pedal operation
- Distance between brake pedal and footrest ①

The top of the brake pedal should be positioned 72 mm (2.8 in) above the top of the footrest. If not, ask a dealer to adjust it.

Soft or spongy feeling → Bleed the brake system.

DISASSEMBLING THE REAR BRAKE CALIPER

1. Remove:

- brake caliper piston
- dust seal ①
- caliper piston seal ②

a. Turn the brake caliper piston counterclockwise to remove it.

b. Remove the dust seal and caliper piston seal.

WARNING:

All internal brake components should be cleaned in new brake fluid only. Do not use solvents as they will cause seals to swell and distort.

2. Check:

- brake caliper pistons ①
Scratches/rust/wear → Replace the brake caliper assembly.
- brake caliper cylinders ②
Wear/scratches → Replace the brake caliper assembly.
- brake caliper body ③
Cracks/damage → Replace.
- brake fluid delivery passage (brake caliper body)
Blockage → Blow out with compressed air.

WARNING:

Replace the caliper piston seals and dust seals whenever the brake caliper is disassembled.

CHASSIS

ASSEMBLING THE REAR BRAKE CALIPER

WARNING:

- *All internal brake components should be cleaned and lubricated with new brake fluid only before installation.*

Must use DOT4 Brake Fluid

- *Replace the caliper piston seal and dust seal whenever a brake caliper is disassembled.*

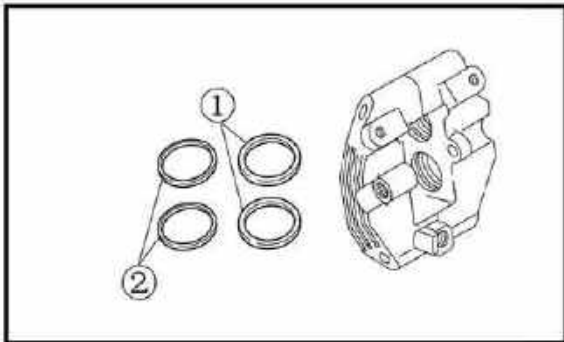

1. Install:

- caliper piston seal ①
- dust seal ②

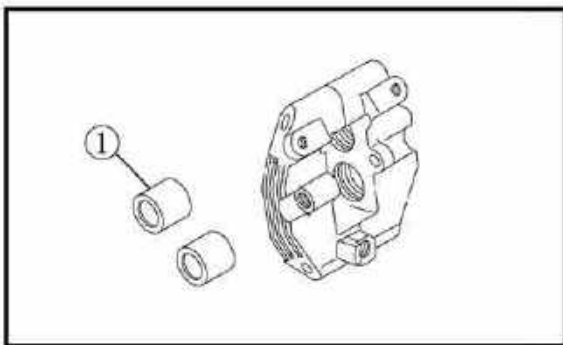

2. Install:

- brake caliper piston ①

CHASSIS

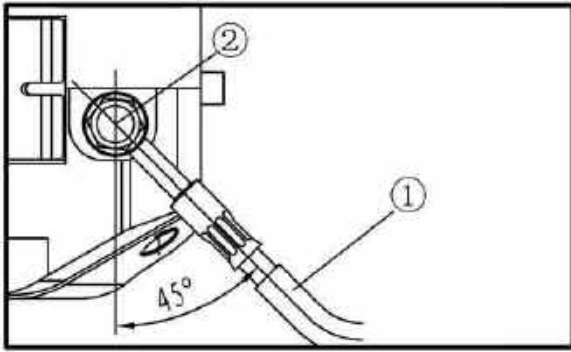

INSTALLING THE REAR BRAKE CALIPER

1. Install:

- brake caliper assembly
- brake caliper mounting bolts

40Nm (4.0m · kg,29 ft · lb)

- brake hose ①
- copper washers
- union bolt ②

48Nm (4.8m · kg,35 ft · lb)

NOTE:

Tighten the union bolt while holding the brake hose as shown.

WARNING:

Proper brake hose routing is essential to insure safe vehicle operation.

2. Fill:

- brake reservoir

Must use DOT4 Brake Fluid

Note:

Brake fluid may damage painted surfaces or plastic parts. Always clean up spilled brake fluid immediately.

3. Air bleed:

- brake system

4. Check:

- brake fluid level

Brake fluid level is below the "LOWER" level line
→ Add the recommended brake fluid to the proper level.

5. Adjust:

- parking brake cable free play

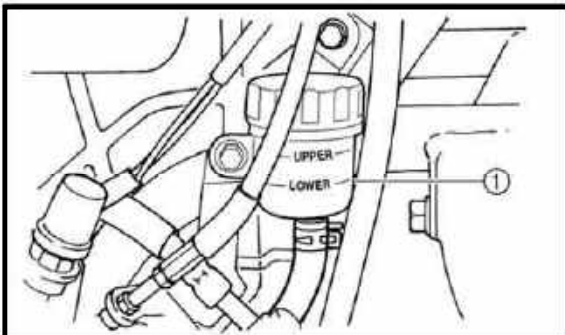

CHASSIS

CHECKING THE MASTER CYLINDER

1. Check:

- brake master cylinder
Wear/scratches → Replace the brake master cylinder assembly.
- brake master cylinder body
Cracks/damage → Replace.
- brake fluid delivery passage (brake master cylinder body)
Blockage → Blow out with compressed air.

2. Check:

- brake master cylinder kit
Scratches/wear/damage → Replace as a set.

3. Check:

- brake fluid reservoir
- brake fluid reservoir diaphragm
Cracks/damage → Replace.

ASSEMBLING THE BRAKE MASTER CYLINDER

WARNING:

- *All internal brake components should be cleaned and lubricated with new brake fluid only before installation.*

Must use DOT4 Brake Fluid

- *Whenever a master cylinder is disassembled replace the piston seals and dust seals.*
-

CHASSIS

INSTALLING THE BRAKE MASTER CYLINDER

1. Install:

- brake master cylinder

16Nm (1.6 m · kg, 11 ft · lb)

2. Install:

- brake pipe

19Nm (1.9 m · kg, 13 ft · lb)

- washer plate
- brake hose
- union bolt

27Nm (2.7 m · kg, 19 ft · lb)

3. Fill:

- brake fluid reservoir

Must use DOT4 Brake Fluid

NOTE:

Brake fluid may damage painted surfaces or plastic parts. Always clean up spilled brake fluid immediately.

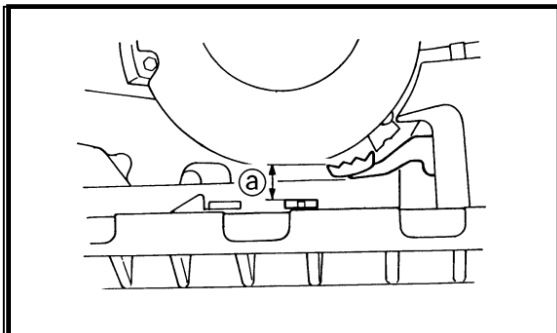
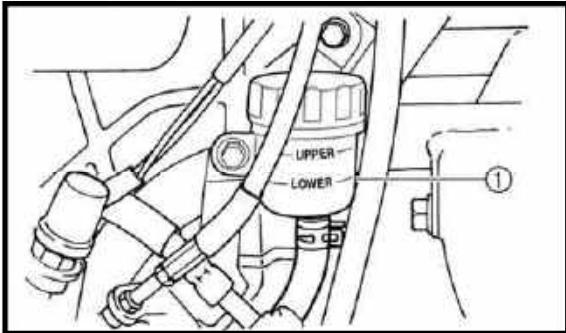

4. Air bleed:

- brake system

5. Check:

- brake fluid level

Brake fluid level is under the "LOWER" level line

Fill up.

6. Adjust:

- brake pedal free play

CHASSIS

FOOTREST ASSEMBLY

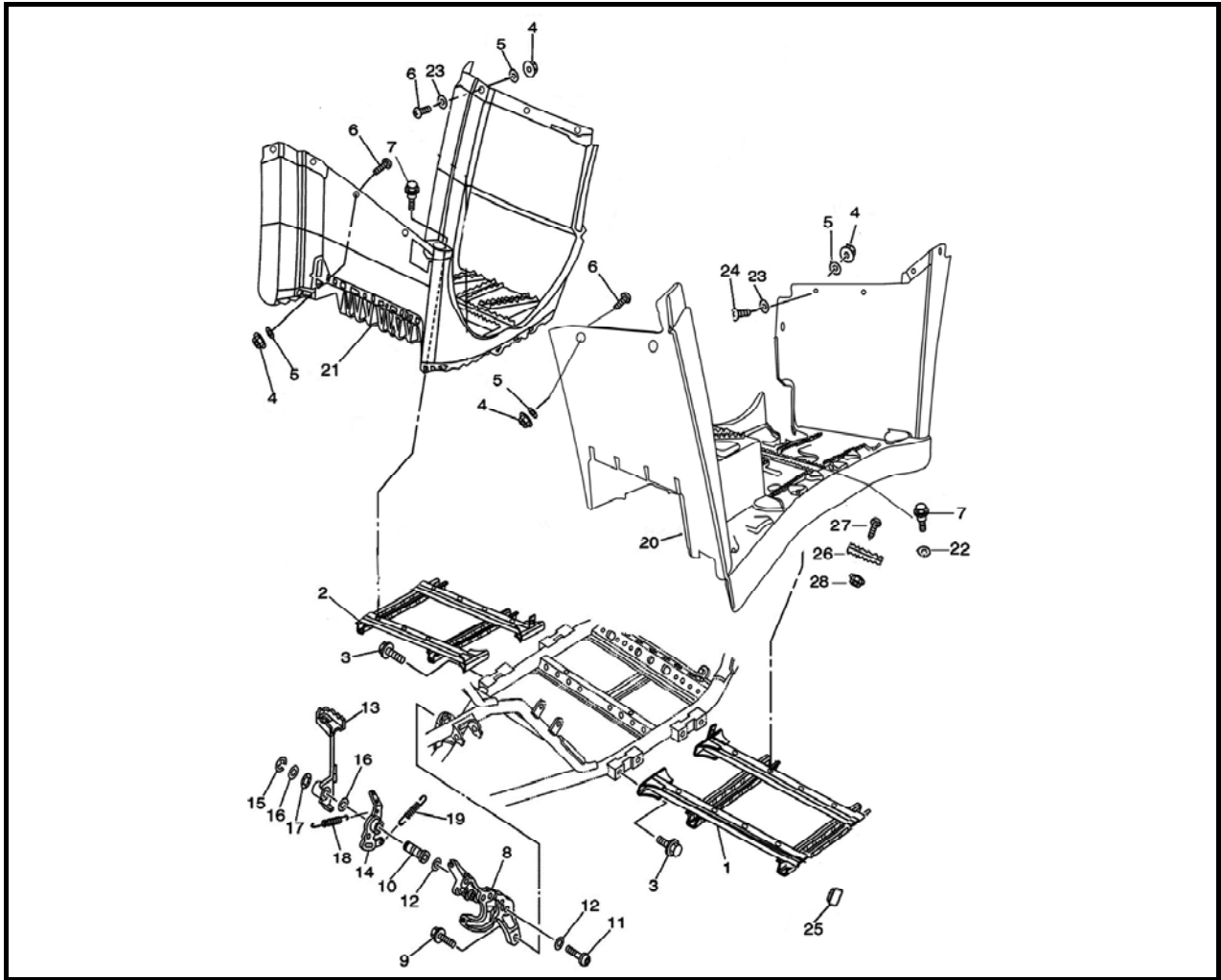

No.	Part Name	Qty	Remarks
	Removing the footrest		
1	Left footrest bracket	1	
2	Right footrest bracket	1	
3	Hexagon flange bolt M10×1.25×16	8	
4	Hexagon flange self-lock nuts M6	8	
5	Washer Φ6×Φ18×1.5	8	
6	Cross large plate head screw M6×25	4	
7	Hexagon flange bolt M6×16	8	
8	Brake pump bracket	1	
9	Hexagon flange bolt M8×25	2	
10	Rear brake pedal pin	1	
11	Hexagon flange bolt M8×25	1	
12	Washer Φ8×Φ16×1.6	2	
13	Welding, parking pedal	1	
14	Rear footrest bracket	1	

CHASSIS

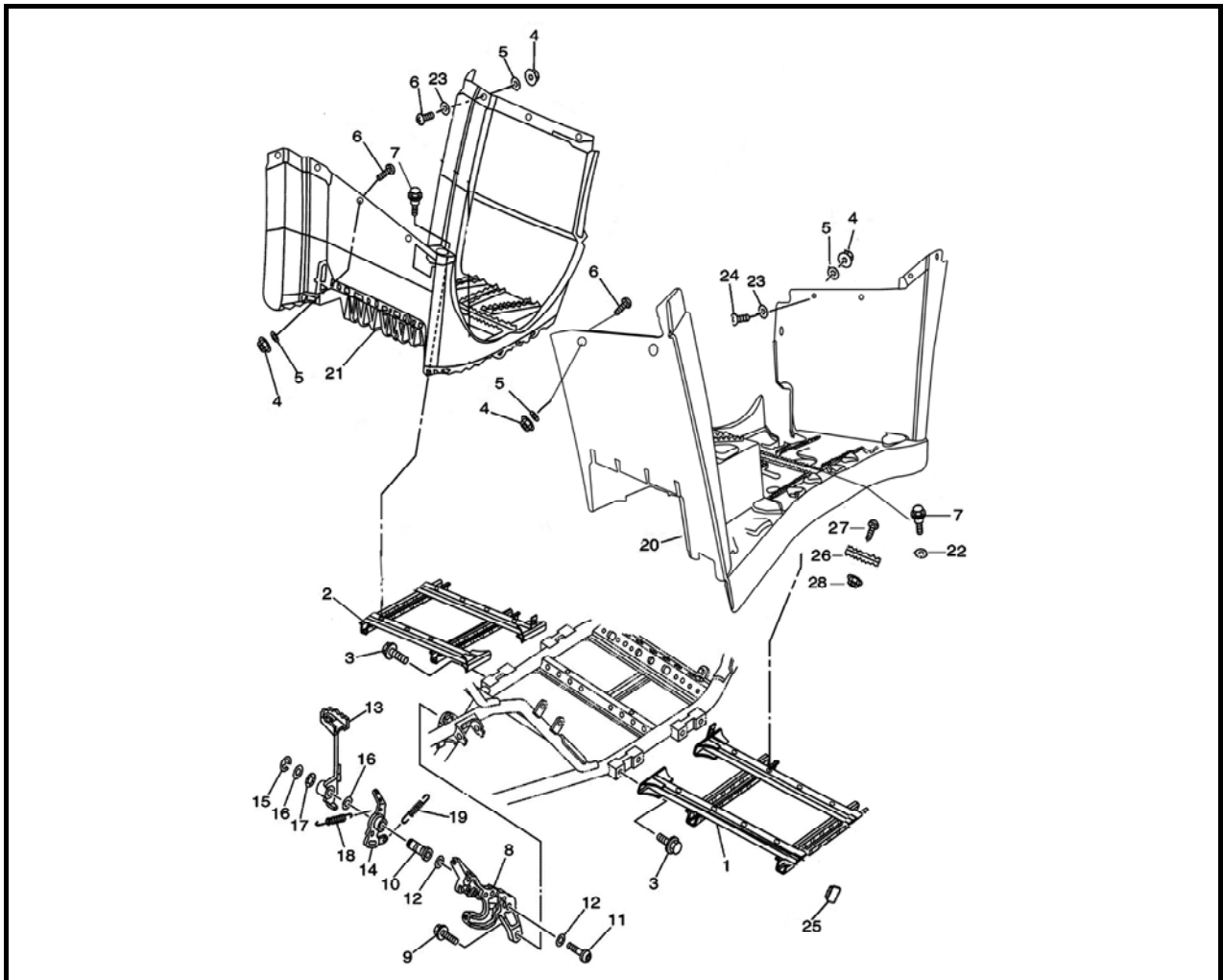

No.	Part Name	Qty	Remarks
15	Split washer $\Phi 12 \times 1$	1	
16	Washer $\Phi 15 \times \Phi 22 \times 1.5$	2	
17	Spring washer $D1=14$	1	
18	Tension spring $\Phi 1.5 \times \Phi 10 \times 66.5$	1	
19	Tension spring $\Phi 1.5 \times \Phi 10 \times 55$	1	
20	Left footrest protector	1	
21	Right footrest protector	1	
22	Washer $\Phi 6 \times \Phi 18 \times 1.5$	8	
23	Rubber washer $\Phi 7 \times \Phi 20 \times 2.5$	8	
24	Cross large plate head screw $M6 \times 20$	4	
25	Stopper 25×25	4	
26	Anti-skidding block, footrest	2	
27	Cross large plate head screw $M5 \times 16$	2	
28	Hexagon flange bolt $M5$	2	

CHASSIS

WHEEL AND TYRE PARTS

FRONT WHEELS

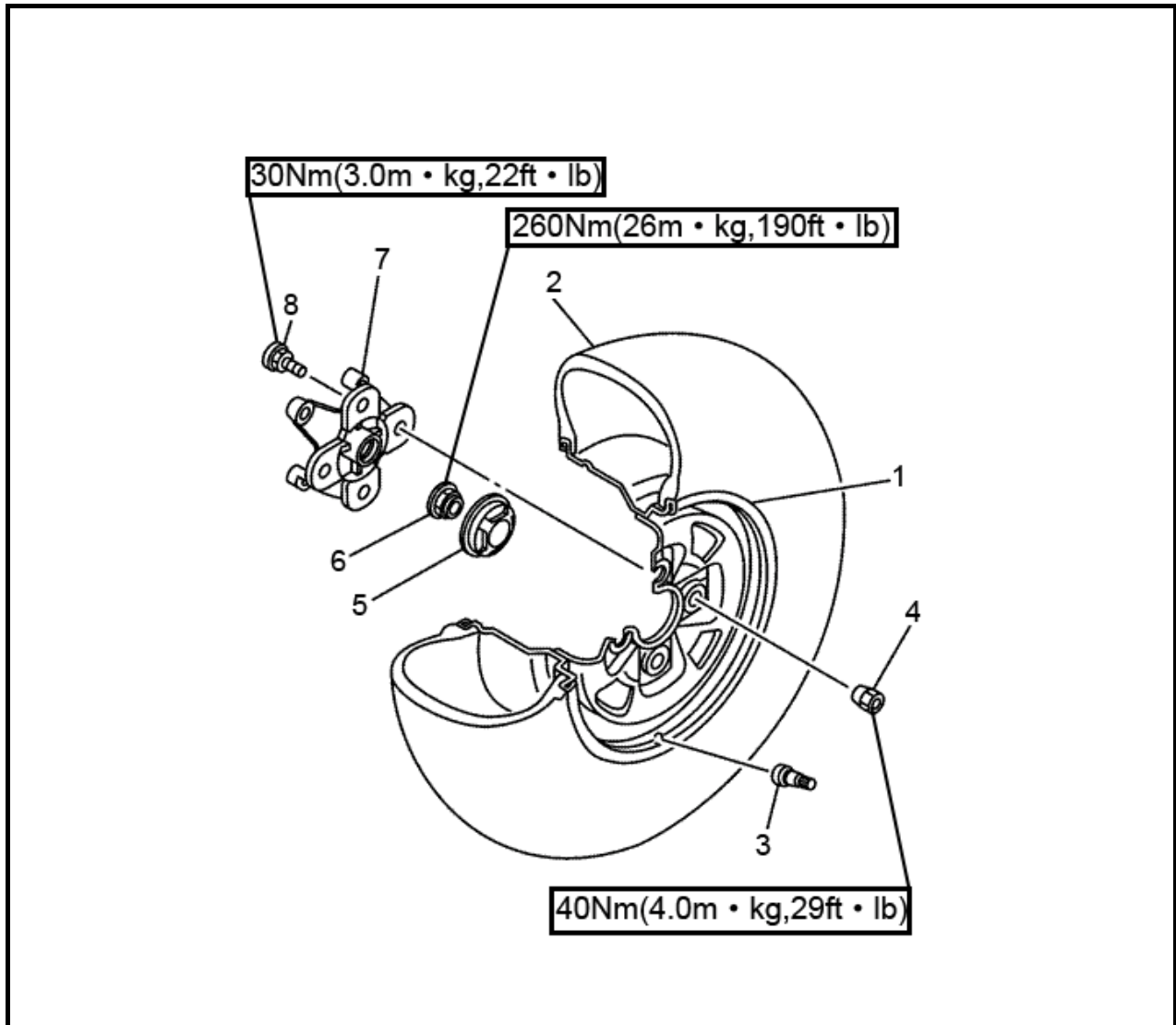

No.	Part Name	Qty	Remarks
Removing the front wheel			
1	Front wheel rim	2	
2	Front tire	2	
3	Valve, rim	2	
4	Nut M10×1.25	8	
5	Center cap	2	
6	Nut M20×1.5	2	
7	Soleplate, front wheel hub	2	
8	Bolt	8	

WARNING: _____
*Securely support the vehicle so
 There is no danger of it falling over.*

CHASSIS

REAR WHEELS

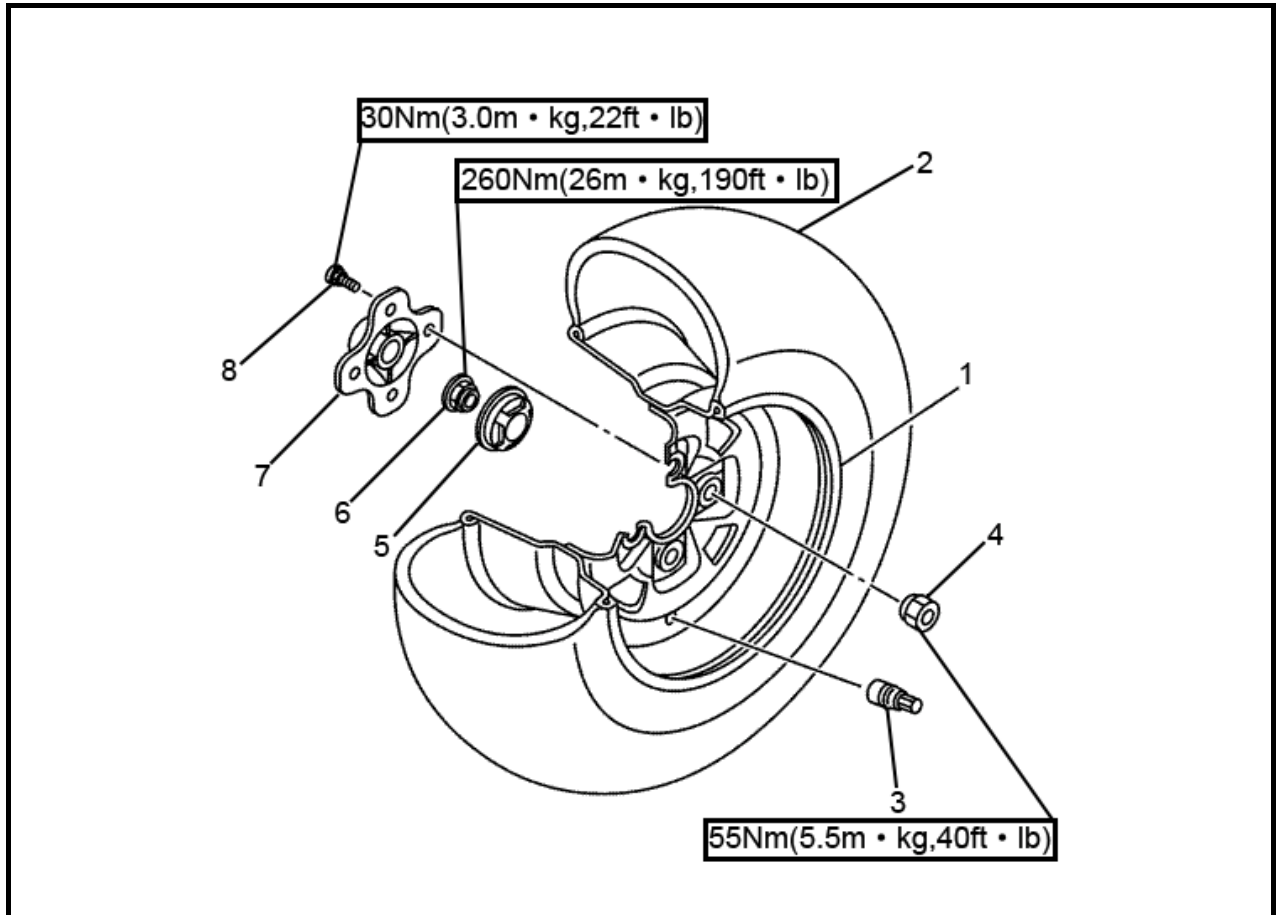

No.	Part Name	Qty	Remarks
1	Rear wheel rim	2	
2	Rear tire	2	
3	Valve, rim	2	
4	Nut M10×1.25	8	
5	Center cap	2	WARNING:
6	Nut M20×1.5	2	<i>Securely support the vehicle so</i>
7	Soleplate, rear wheel hub	2	<i>There is no danger of it falling over.</i>
8	Bolt	8	

CHASSIS

FRONT AND REAR WHEEL RIM (DIFFERENT MODEL)

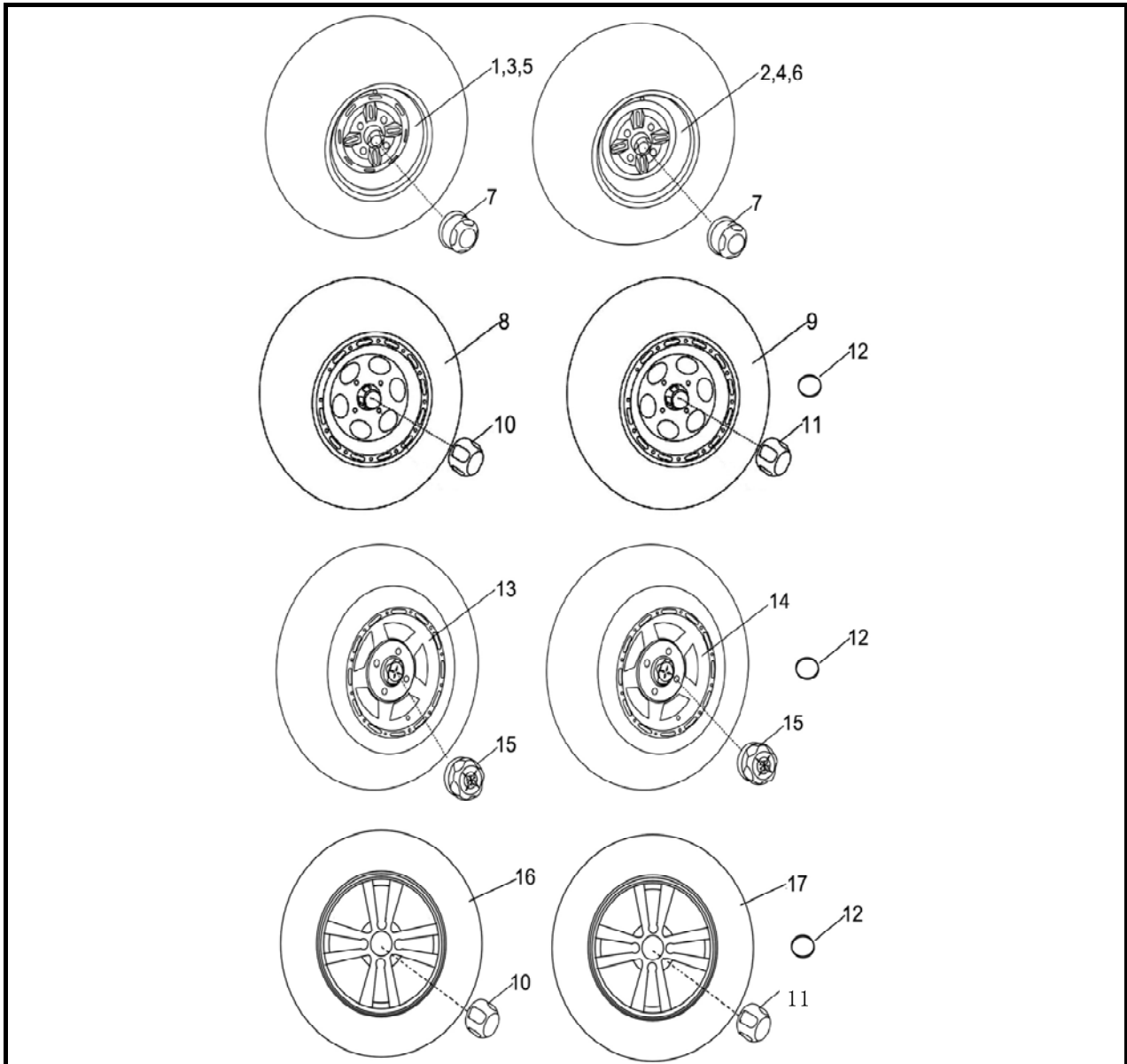

No.	Part Name	Qty	Remarks
1	Front rim 103(steel, yellow)	2	
2	Rear rim 103(steel, yellow)	2	
3	Front rim 103(steel, silver)	2	
4	Rear rim 103(steel, silver)	2	
5	Front rim 103(steel, black)	2	
6	Rear rim 103(steel, black)	2	
7	Wheel decoration cover Z103	4	
8	Front rim 104(aluminum)	2	
9	Rear rim 104(aluminum)	2	
10	Wheel decoration cover II -Z104	2	

CHASSIS

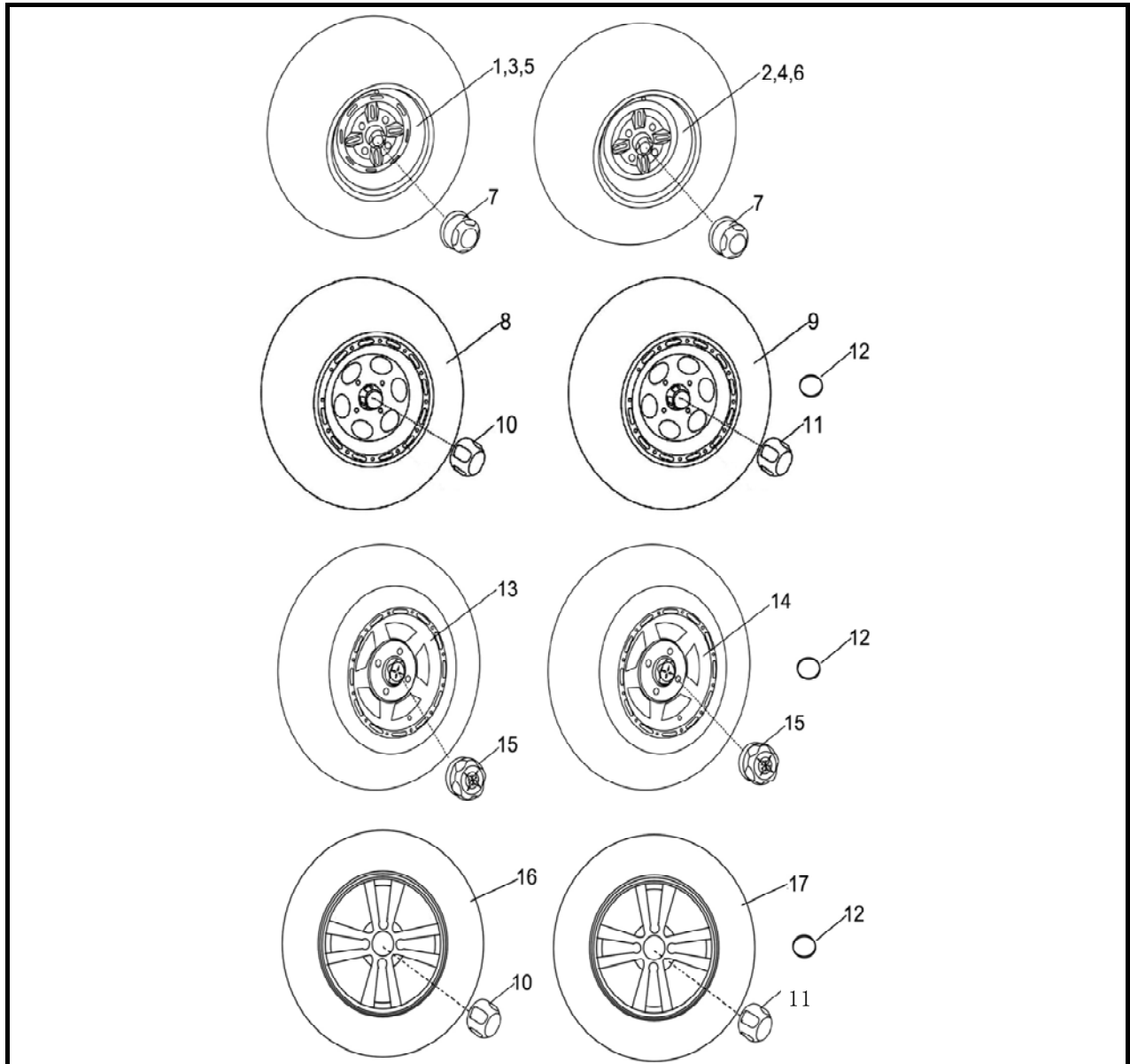

No.	Part Name	Qty	Remarks
11	Wheel decoration cover III-Z105	2	
12	Clamping spring, decoration cover	4	
13	Front rim-109(aluminum)	2	
14	Rear rim-109(aluminum)	2	
15	Wheel decoration cover V -Z107	8	
16	Front rim 111(aluminum)	2	
17	Rear rim 111(aluminum)	2	

CHASSIS

CHECKING THE WHEEL TYRE

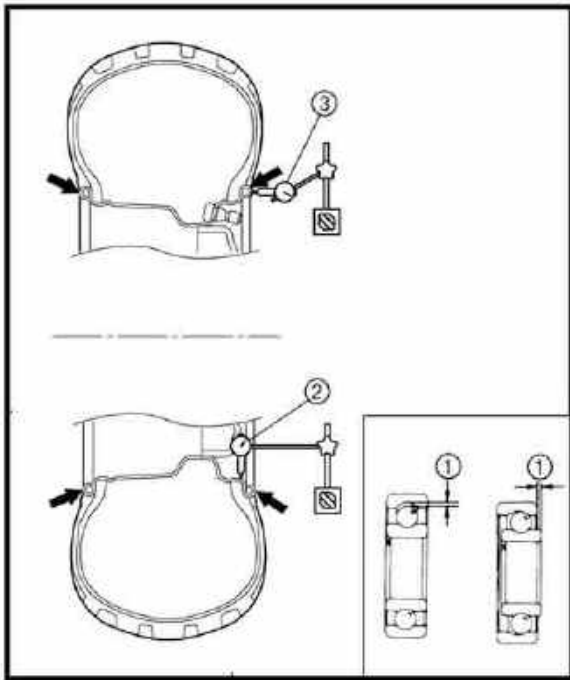

1. Check:

- wheel tyre

2. Measure:

- wheel runout

Over the specified limit → Replace the wheel or check the wheel bearing play ①.

3. Check:

- wheel balance

Out of balance

→ Adjust.

Wheel runout limit
Radial ②: 2.0 mm (0.08 in)
Lateral ③: 2.0 mm (0.08 in)

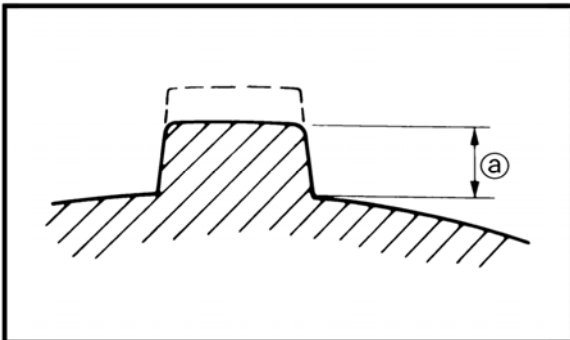

WARNING:

The profile depth falls below 3mm, Please replace the tyre immediately.

- tire wear limit @

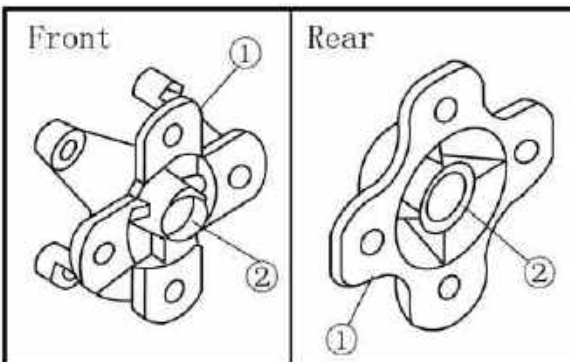

CHECKING THE WHEEL HUB

1. Check:

- wheel hub ①

Cracks/damage → Replace.

- splines (wheel hub) ②

Wear/damage → Replace.

- nuts (wheel hub)

loosen or distorted → Replace or tighten

CHASSIS

INSTALLING THE WHEEL HUB

1. Install:
 - axle nut

260 Nm (26.0 m · kg, 190 ft · lb)

INSTALLING THE WHEEL TYRE

1. Install:
 - wheel

NOTE:

The arrow mark ① on the tyre must point in the direction of rotation A of the wheel.

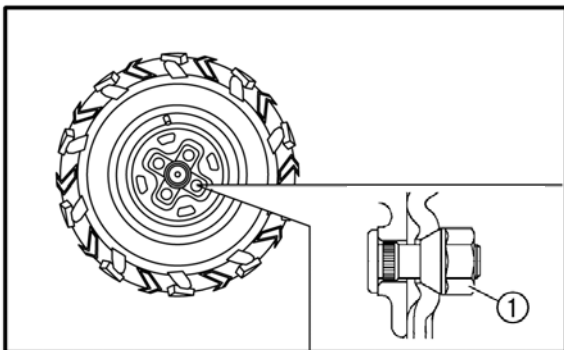
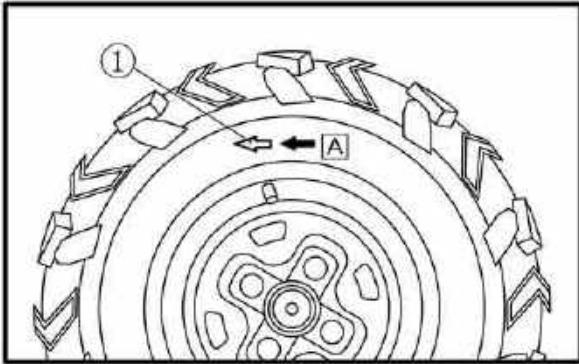

2. Tighten:
 - wheel nuts ①

The angle of the conical bores is 60°

WARNING:

Tapered wheel nuts ① are used for both the front and rear wheels. Install each nut

CHASSIS

SPECIFICATION OF WHEEL AND TYRE

	Wheel hub Dimension	Tyre Dimension	Tyre Pressure (Kpa /PSI)
Front Wheel	12×6.AT	25×8-12	70/10
		26×9-12	70/10
Rear Wheel	12×8.AT	25×10-12	70/10
		26×10-12	70/10

- Since wheels and tyres are crucial to the vehicle operation, inspection for tyre pressure and profile depth is necessary.
- To ensure maximum security and longer life expectancy of the wheel, please periodically inspect the tyre pressure and profile depth. Insufficient tyre pressure can result in not only intensified wearing of the tyre but also instability during the course of operating the vehicle (such as hard turning). Excessive tyre pressure can also reduce the friction force between the tyre and ground, causing spinning or lose of control. Therefore, please ensure the tyre pressure strictly complies with figures shown in the chart above.
- Before operating the vehicle each time, please check if profile depth of the tyre is over worn, which might result in spinning, instability, lose of control and other potential security risk of the vehicle.

CHASSIS

TRANSMISSION SYSTEM

Front Bridge

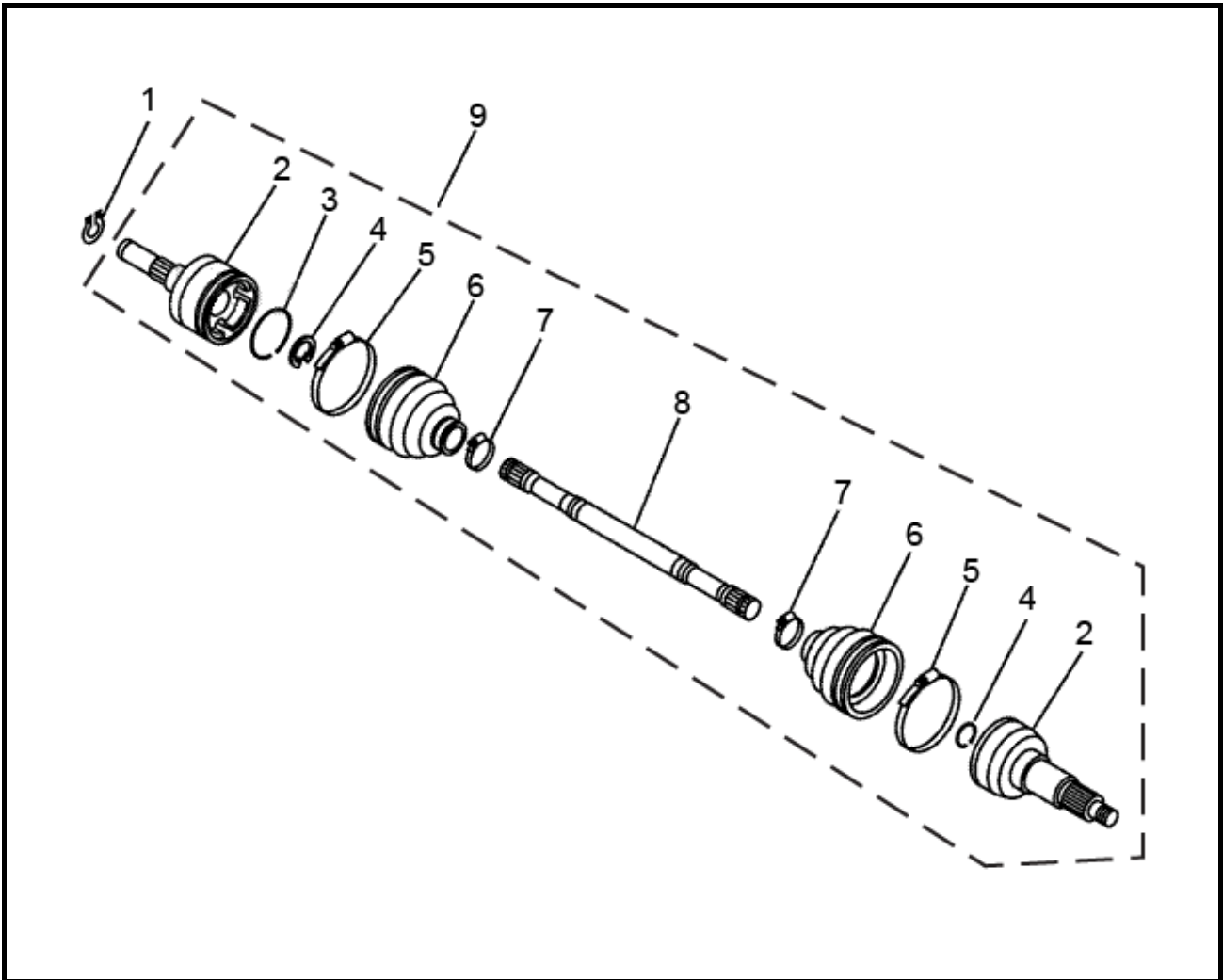

No.	Part Name	Qty	Remarks
	Removing the front bridge		
1	Circlip	1	
2	Double off-set joint assembly	2	
3	Circlip	1	
4	Circlip	2	
5	Boot band	2	
6	Dust boot	2	
7	Boot band	2	
8	Joint shaft	1	
9	Half axle assembly	1	

CHASSIS

Front Bridge

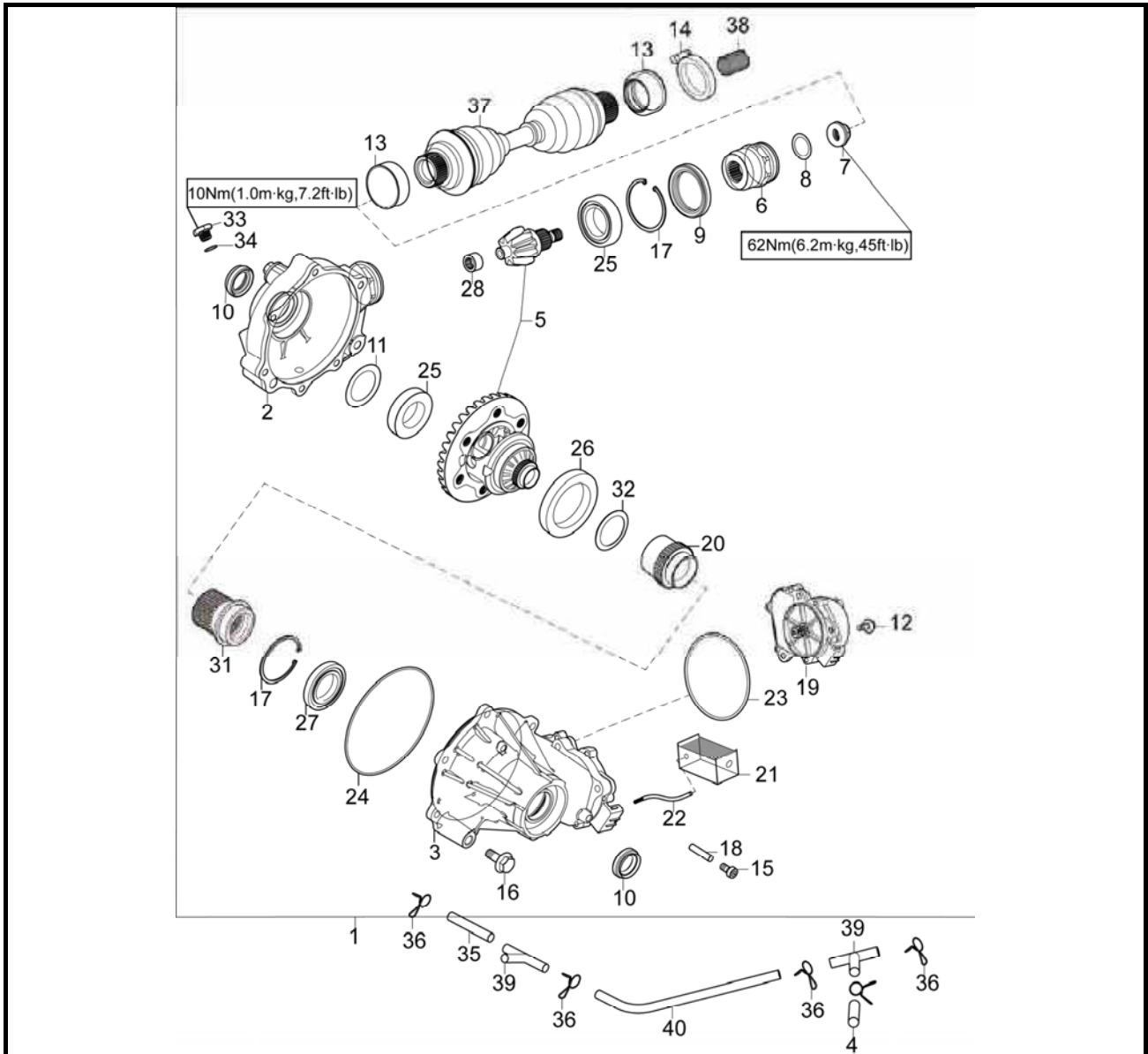

No.	Part Name	Qty	Remarks
	Removing the front bridge	1	
1	Front differential assy	1	
2	Front axle differential case II	1	
3	Front axle differential case I	1	
4	Rubber tube V, $\Phi 7 \times \Phi 11 \times 90$	1	
5	Drive & driven gears assy	1	
6	Mounting bracket, drive gears, front axle	1	
7	Hexagon flange self-lock nuts M14×1.25	1	
8	O-type ring $\Phi 14 \times \Phi 7$	1	
9	Oil seal $\Phi 48 \times \Phi 65 \times 9$, front axle input shaft	1	

CHASSIS

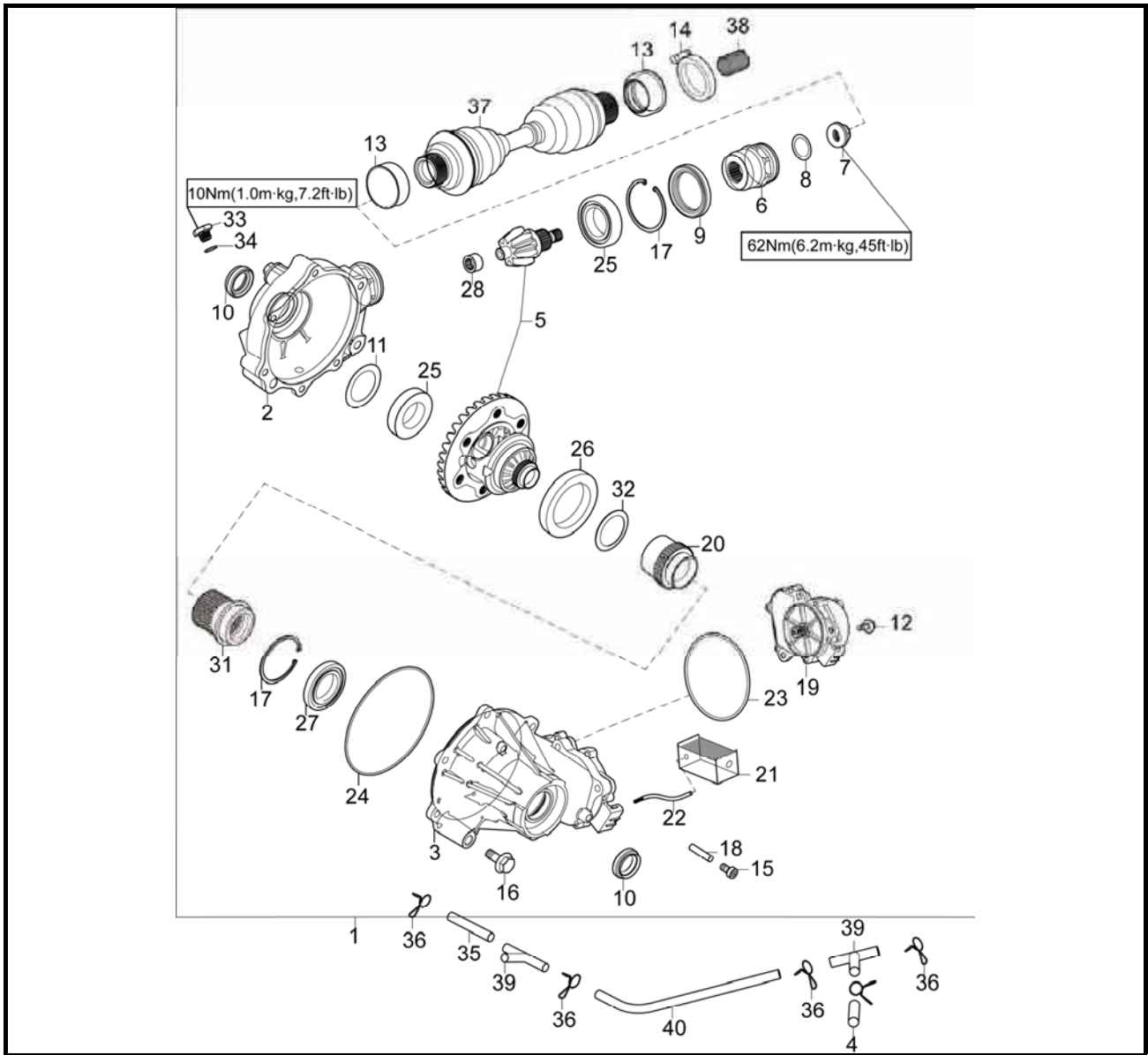

No.	Part Name	Qty	Remarks
10	Oil Seal $\Phi 24 \times \Phi 38 \times 8$, front axle output shaft	2	
11	Adjustment gasket $\Phi 50 \times \Phi 61.5$, differential	2	
12	Socket hexagon screw M8×25	3	
13	Front dustproof rubber cover	2	
14	Hoop $\Phi 33-57$	1	
15	Socket hexagon screw M8×20	1	
16	Socket hexagon screw M8×25	6	
17	Spring washer D0=62	2	
18	Column pin $\Phi 5 \times 80$	1	
19	Transfer case assembly	1	
20	Sliding sleeve, divide device connection	1	

CHASSIS

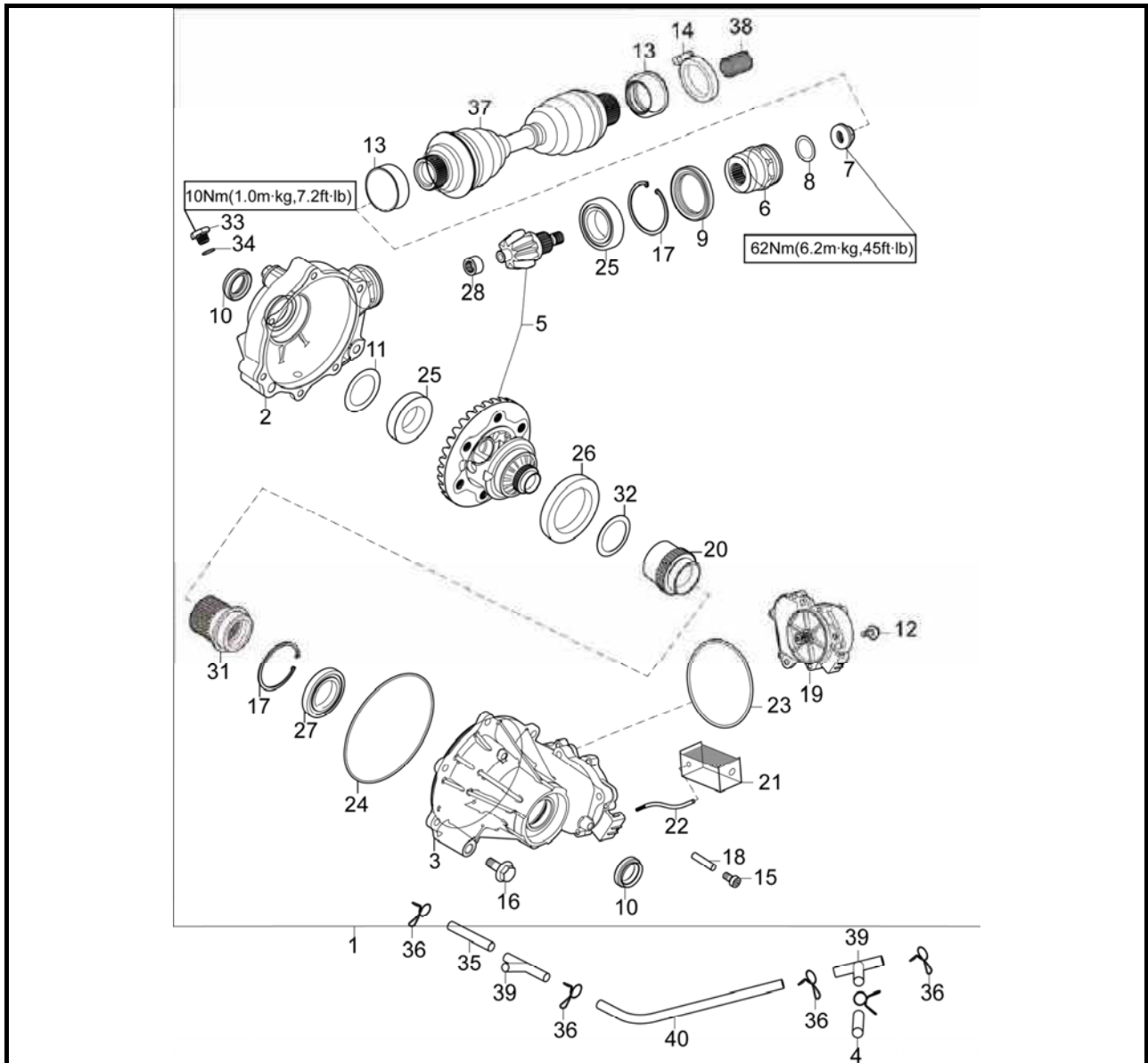

No.	Part Name	Qty	Remarks
21	Rack	1	
22	Shaft fork	1	
23	O-ring $\Phi 2 \times \Phi 81$	1	
24	O-ring $\Phi 2.4 \times \Phi 140$	1	
25	Bearing 6007R	2	
26	Bearing 6912	1	
27	Bearing 16007	1	
28	Bolling bearing HK152112	1	
29	Oil drain bolt M10×16	1	
30	Copper washer $\Phi 1.5 \times \Phi 9$	1	

CHASSIS

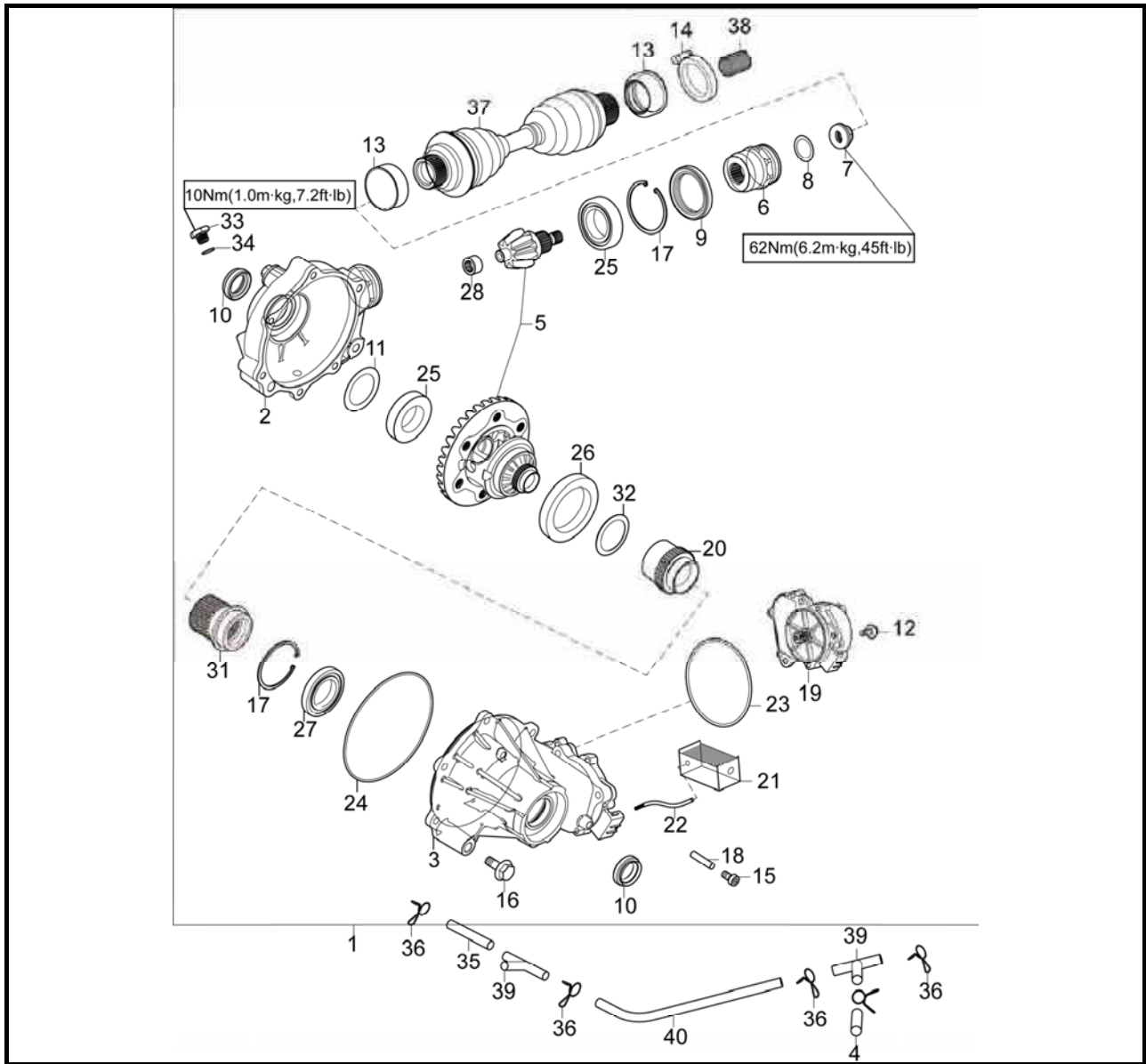

No.	Part Name	Qty	Remarks
31	Divide device connection	1	
32	Adjustment gasket $\Phi 71 \times \Phi 83$	1	
33	Hexagon flange bolt M14 \times 1.5 \times 10	1	
34	Copper washer $\Phi 14 \times 2$	1	
35	Vent pipe L=700mm	1	
36	Clip $\Phi 10$	6	
37	Front transmission shaft	1	
38	Spring $\Phi 2 \times \Phi 18.5 \times 30$	1	
39	Triplet Joint li	2	
40	Secondary water tank rubber pipe II $\Phi 7 \times \Phi 11 \times 750$	1	

CHASSIS

Front Bridge

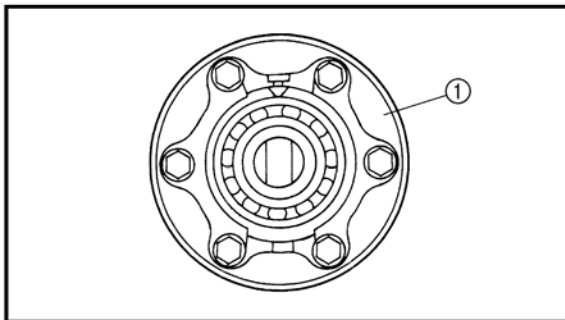
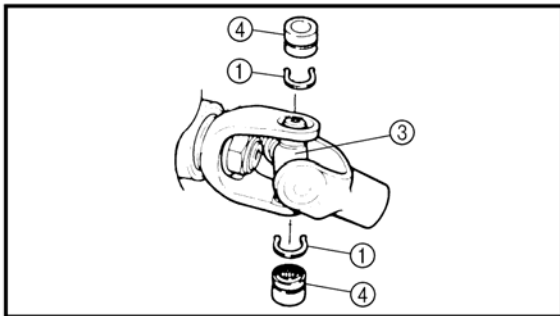
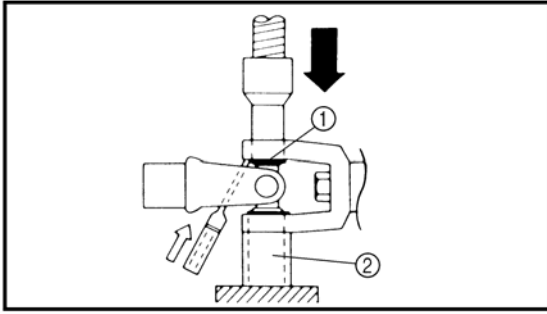

DISASSEMBLING THE UNIVERSAL JOINT

Remove:

- universal joint
 - a. Remove the circlips ①.
 - b. Place the universal joint in a press.
 - c. With a suitable diameter pipe ② beneath the yoke ③, press the bearing ④ into the pipe as shown.
 - d. Repeat the steps for the opposite bearing.
 - e. remove the yoke.

NOTE:

It may be necessary to lightly tap the yoke with a punch.

REMOVING THE DIFFERENTIAL GEAR ASSEMBLY

Remove:

- differential gear assembly

NOTE:

The ring gear and the differential gear should be fastened together. Do not disassemble the differential gear assembly.

CHASSIS

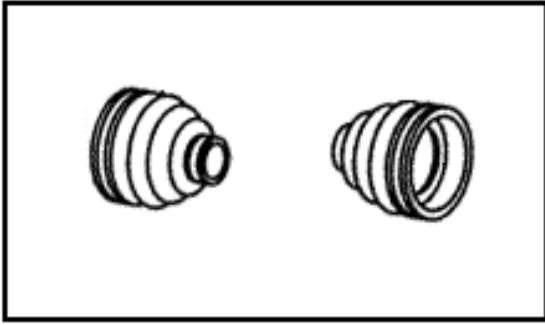

CHECKING THE JOINTS

1. Check:

- Dust boots
- Cracks/damage → Replace

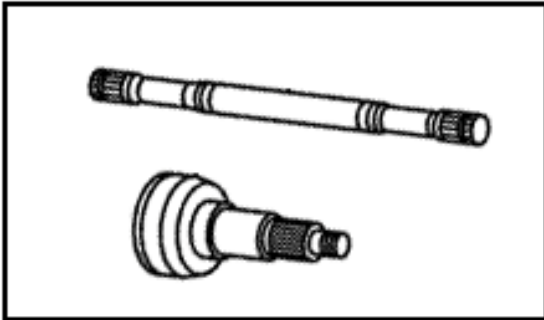

2. Check:

- double off-set joint spline
 - ball joint spline
 - shaft spline
- Wear/damage → Replace.
- balls and ball races
 - inner surface of double off-set joint
- Pitting/wear/damage → Replace.

· Check whether the inner and outer ball cage of the left and right transmission shaft movement is Smooth, ceaseless. If it is stagnation and obvious becoming less loosen, replace it.

· Disassemble the left and right transmission shaft, cleaning and assemble it again.

NOTE :

1. The dustproof rubber wrap on the ball cage is not allow to contact with the gas and diesel oil.

2. The dustproof rubber wrap does not allow to be scratched, a slight scratches can damage the dustproof rubber wrap very quickly.

3. When reassembles the left and right transmission shaft, in the ball cage must sufficiently enter 2/3 volume with the Lithium lubricating.

CHECKING THE DIFFERENTIAL GEAR

1. Check:

- gear teeth

CHASSIS

Pitting/galling/wear → Replace drive pinion gear and ring gear as a set.

- bearings

Pitting/damage → Replace.

- oil seals

- O-rings

Damage → Replace.

2. Check:

- drive shaft splines

- universal joints

- drive pinion gear splines

Wear/damage → Replace.

- spring

Fatigue → Replace.

Move the spring up and down.

3. Check:

- front drive shaft

Bends → Replace.

- torque limiter

Loose → Replace the front drive shaft.

Apply lithium-soap-based grease to the oil seal, front box output shaft and oil seal, front box input shaft and differential gear assembly

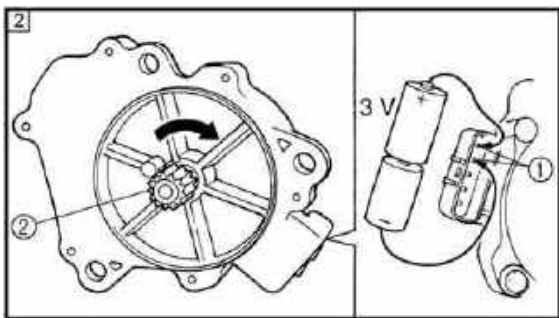
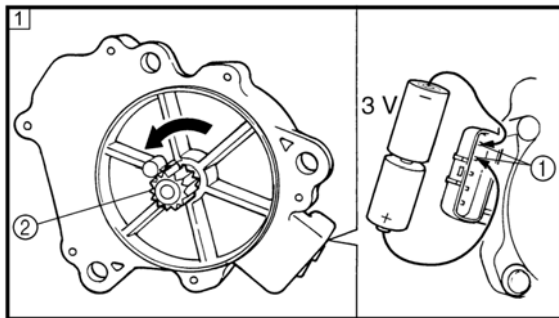

CHECKING THE GEAR MOTOR

Check:

- gear motor

a. Connect two C size batteries to the gear motor terminals ①.

NOTE:

• Do not use a 12 V battery to operate the pinion gear.

• Do not connect the batteries to the gear motor when it is installed in the gear case. The gear motor should be checked when it is removed from the gear case.

1 Check that the pinion gear ② turns counterclockwise.

2 Check that the pinion gear ② turns clockwise.

CHASSIS

ASSEMBLING THE UNIVERSAL JOINT

Install:

- universal joint
- a. Install the opposite yoke into the universal joint.
- b. Apply wheel bearing grease to the bearings.
- c. Install the bearing ① onto the yoke.
- d. Press each bearing into the universal joint using a suitable socket.

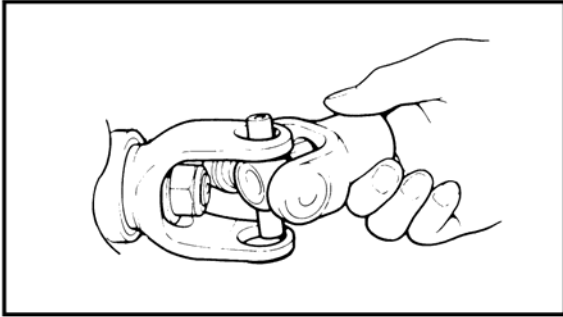

CAUTION:

Check each bearing. The needles can easily fall out of their races. Slide the yoke back and forth on the bearings; the yoke will not go all the way onto a bearing if a needle is out of plate.

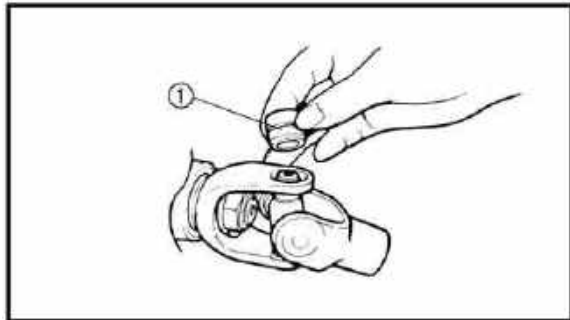

NOTE:

The bearing must be inserted far enough into the universal joint so that the circlip can be installed.

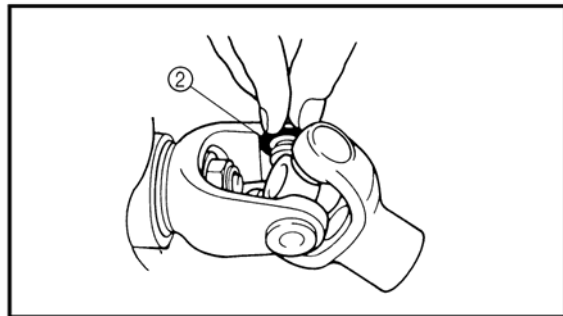

- e. Install the circlips ② into the groove of each bearing.

ADJUSTING THE DIFFERENTIAL GEAR LASH

1. Remove:
 - differential gear assembly
2. Adjust :
 - gear lash

CHASSIS

ASSEMBLING THE DIFFERENTIAL GEAR

1. Measure:

- gear lash

2. Install :

- gear motor

a. Installed to the differential gear, to the right to put it into the 2WD mode.

b. Connect two C size batteries to the gear motor terminal ① to operate the pinion gear ②. Operate the pinion gear until the paint mark ③ on the gear is aligned with the paint mark ④ on the gear motor case.

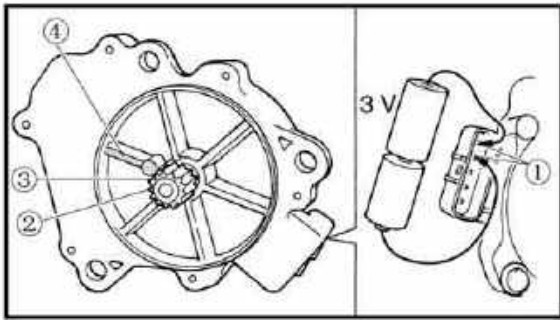

CAUTION:

Do not use a 12 V battery to operate the pinion gear.

c. Insert bolts ⑤ into the gear motor ⑥ and use them as a guide to set the motor on the differential gear assembly ⑦ so that the shift fork sliding gear ⑧ does not move.

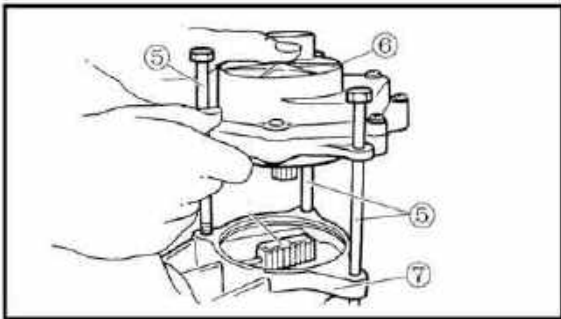

CAUTION:

If the position of the shift fork sliding gear is moved, the position of the differential gear and the indicator light display may differ, and the 2WD or differential lock mode may not be activated.

d. Remove the bolts, and then install the motor with the gear motor bolts.

CHASSIS

Rear Bridge

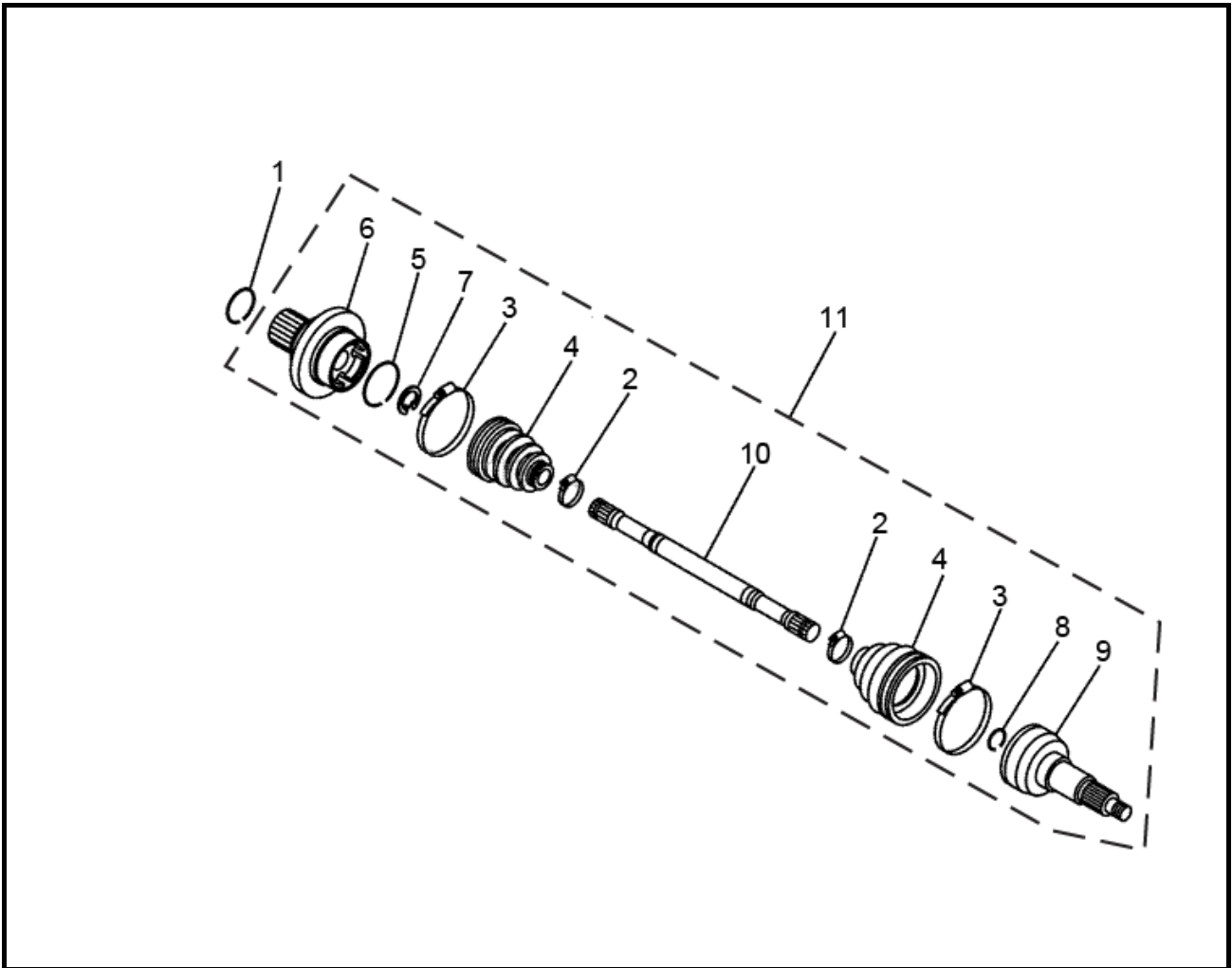

No.	Part Name	Qty	Remarks
	Removing the rear bridge		
1	Circlip	2	
2	Boot band	2	
3	Boot band	2	
4	Dust boot	2	
5	Circlip	1	
6	Double off-set joint assembly	1	
7	Circlip	1	
8	Circlip	1	
9	Double off-set joint assembly	1	
10	Joint shaft	1	
11	Half axle assembly	1	

CHASSIS

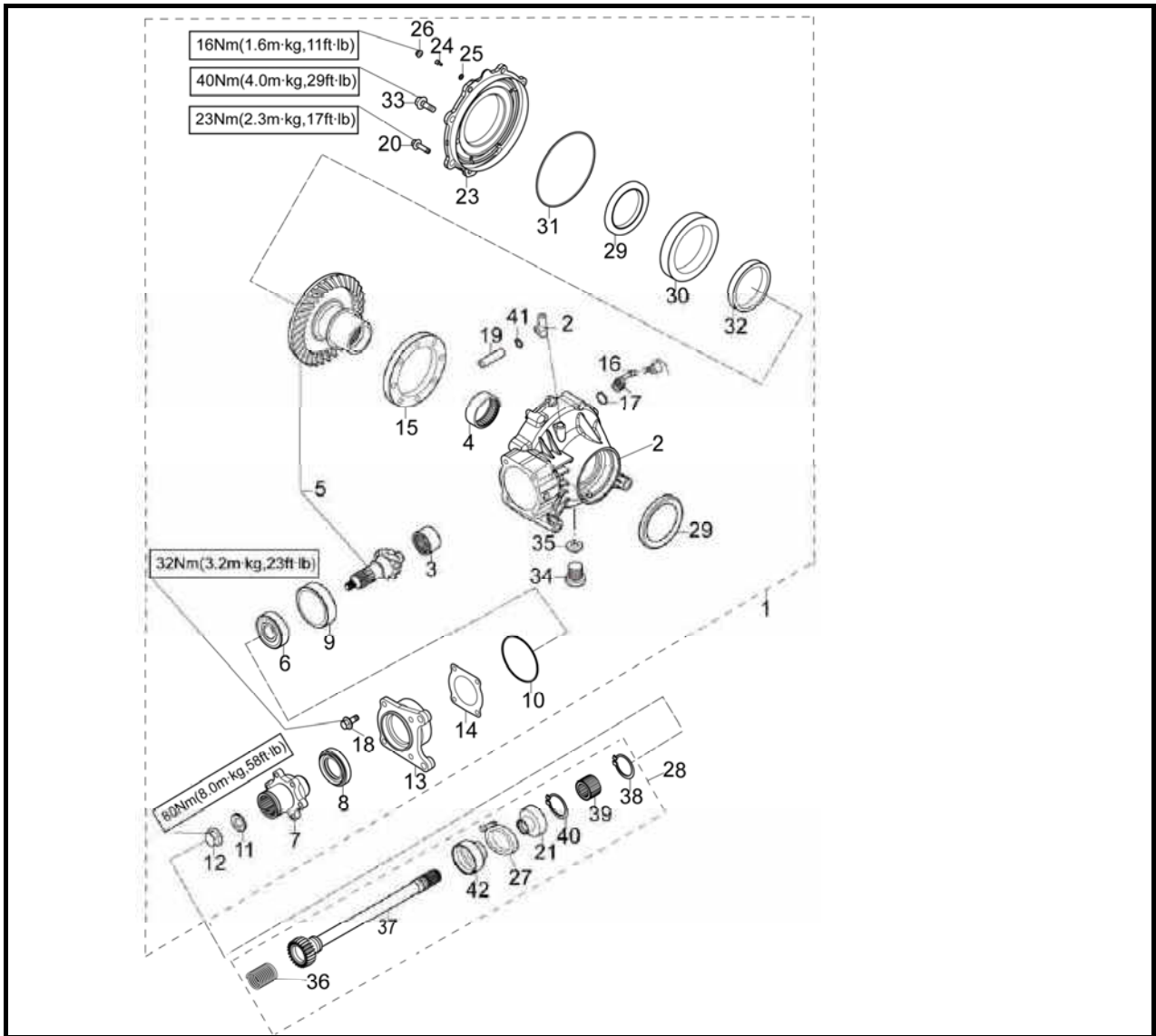

No.	Part Name	Qty	Remarks
	Removing the rear bridge		
1	Rear differential assy	1	
2	Rear axle differential case I	1	
3	Needle bearing HK223013	1	
4	Needle bearing HK556720	1	
5	Driving and driven gears, rear axle	1	
6	Bearing 6305	1	
7	Mounting bracket, rear disk brake	1	
8	Oil seal $\Phi 61 \times \Phi 35 \times 9$, input shaft	1	
9	Bushing	1	
10	O-ring $\Phi 3 \times \Phi 71$, rear driving gear	1	
11	Washer $\Phi 12 \times \Phi 30 \times 4$	1	

CHASSIS

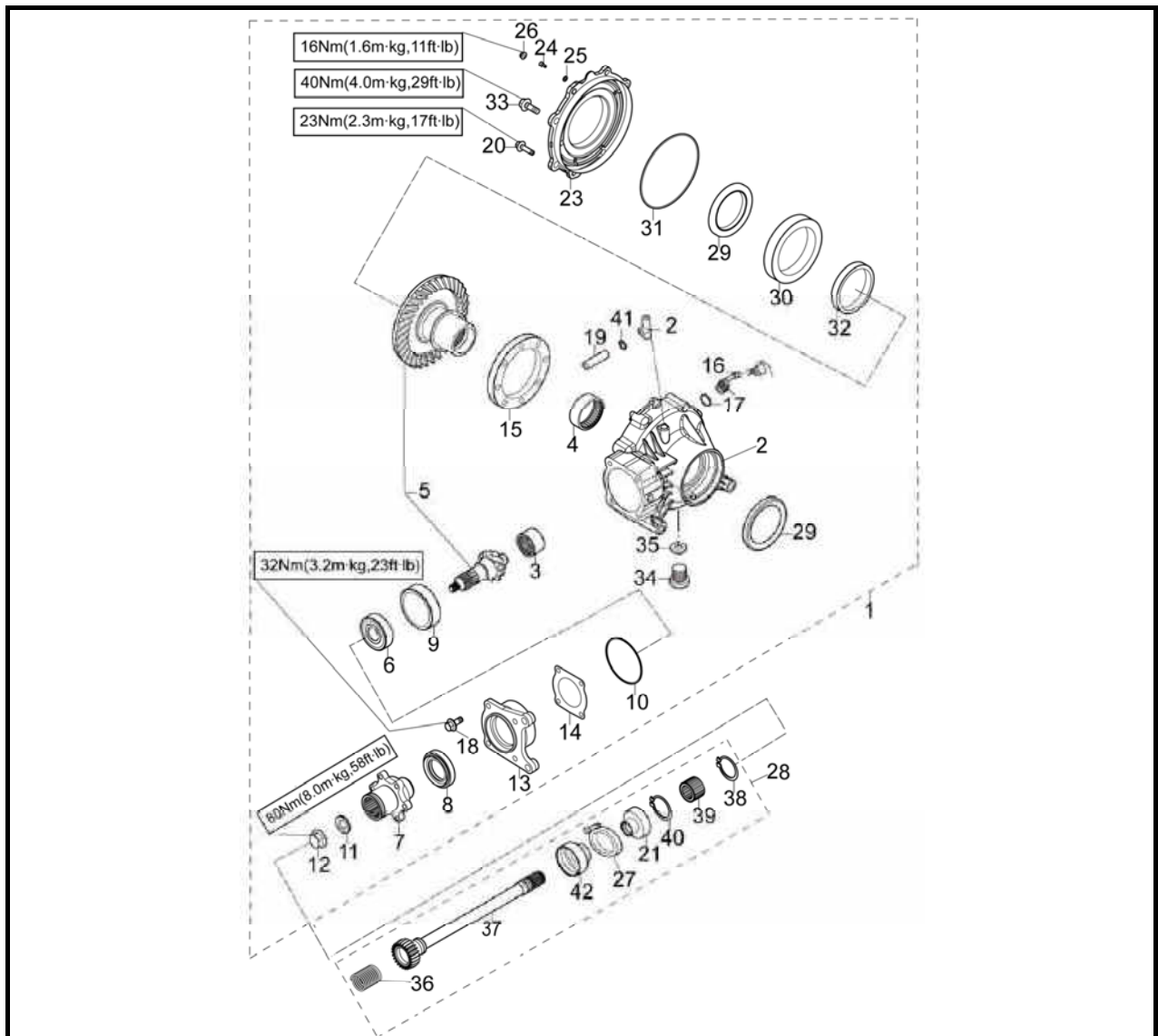

No.	Part Name	Qty	Remarks
12	Hexagon flange self-Lock nuts M12×1.25	1	
13	Mount bracket, rear driving gear	1	
14	Rear adjustment gasket I	2	
15	Rear adjustment gasket II	1	
16	Speed sensor	1	
17	O-ring gasket Φ19.4×Φ2.3, fuel injection	1	
18	Socket hexagon screw M8×25	4	
19	Vent pipe(L=720Mm), rear axle	1	
20	Socket hexagon screw M8×25	6	
21	Rear dust cover, rear axle	1	
22	Nozzle joint	1	
23	Rear differential case I	1	

CHASSIS

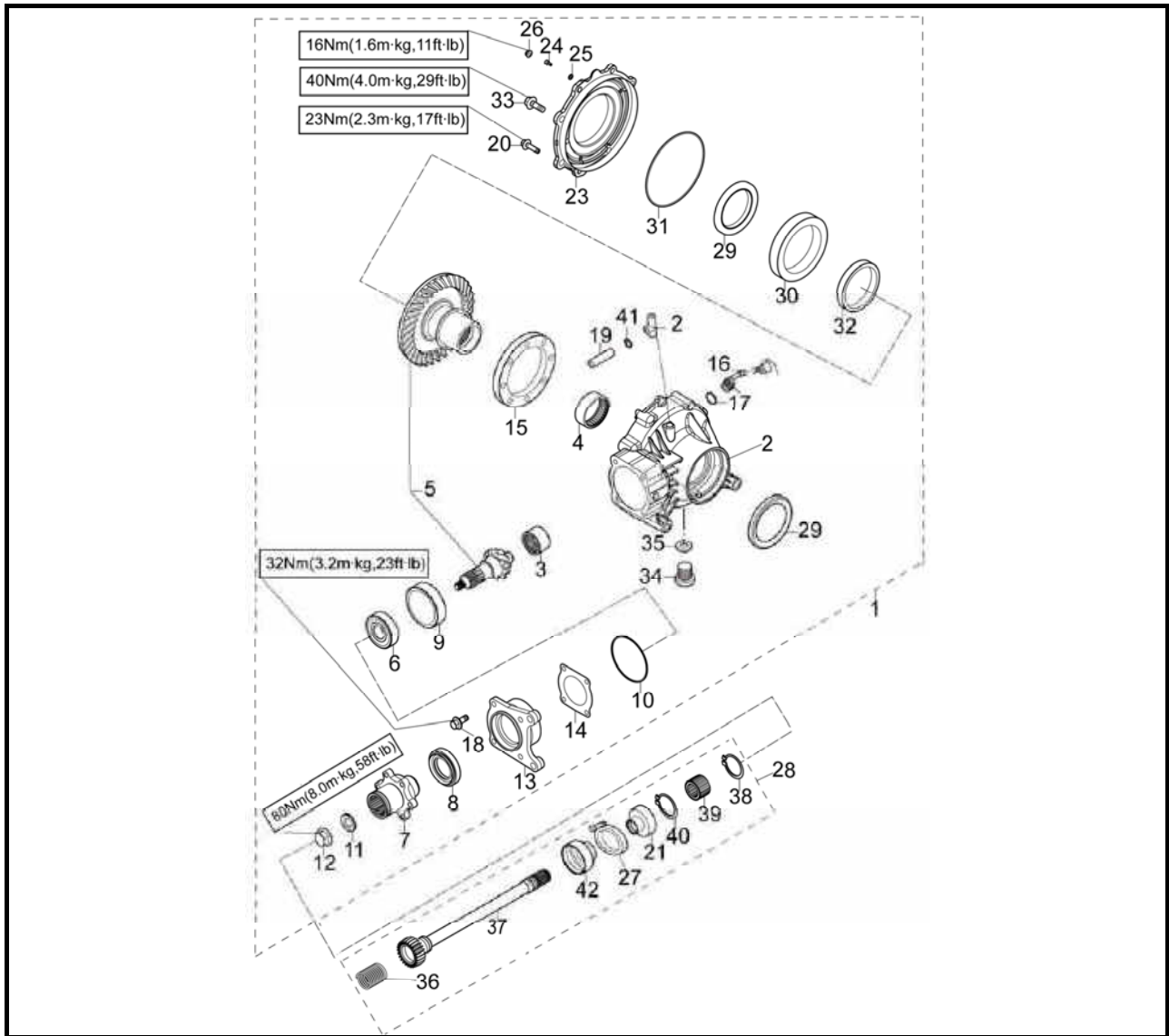

No.	Part Name	Qty	Remarks
24	Hexagon bolt M8×45	4	
25	Washer Φ8.5	1	
26	Hexagon flange nut M8	1	
27	Screw hoop Φ20-32	2	
28	Front transmission shaft assy	1	
29	Oil seal Φ65×Φ90×9, output shaft	2	
30	Bearing 16017	2	
31	O-ring Φ3.1×Φ150	1	
32	Adjustment gasket III	2	
33	Hexagon flange nut M10×1.25×25	2	
34	Fuel drain plug M20×1.5×12	1	
35	Copper washer Φ14×2	2	

CHASSIS

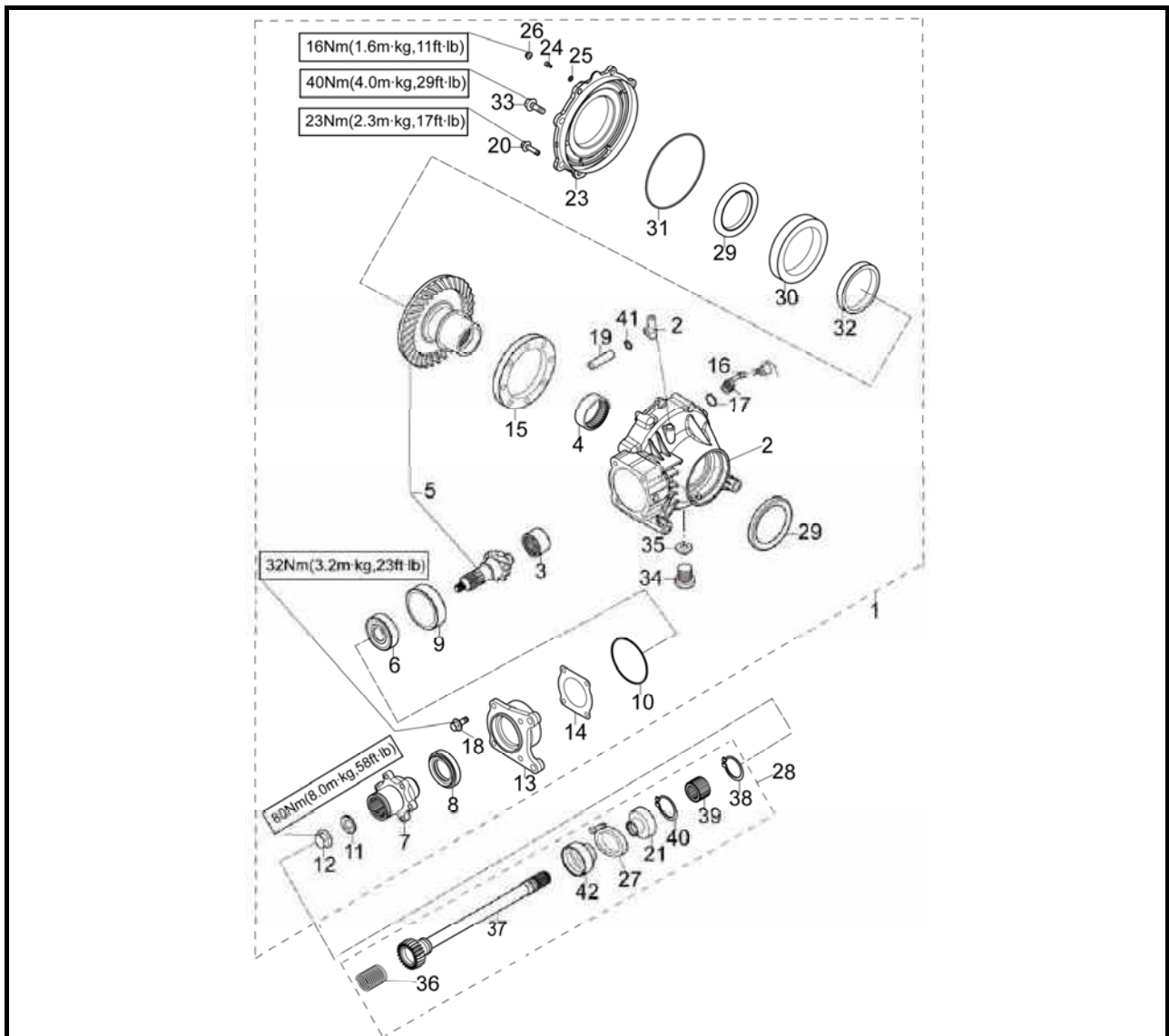

No.	Part Name	Qty	Remarks
36	Spring $\Phi 14 \times \Phi 1.8 \times 46$	1	
37	Rear transmission shaft	1	
38	A Type circlip D0=22	4	
39	Jointsleeve, rear axle transmission shaft	1	
40	A type circlip D0=19	1	
41	Clip $\Phi 14$	1	
42	Front dust cover, rear axle	1	

CHASSIS

Rear Bridge

(The service method of the rear bridge parts is as the same as the front bridge parts, please refer to the before-mentioned to operate.)

NOTE: _____
Apply lithium-soap-based grease to the bearing assembly and o-ring and bearing and driven gear and oil seal and drive shaft coupling and final drive pinion gear bearing housing.

CHASSIS

Reverse mechanism parts

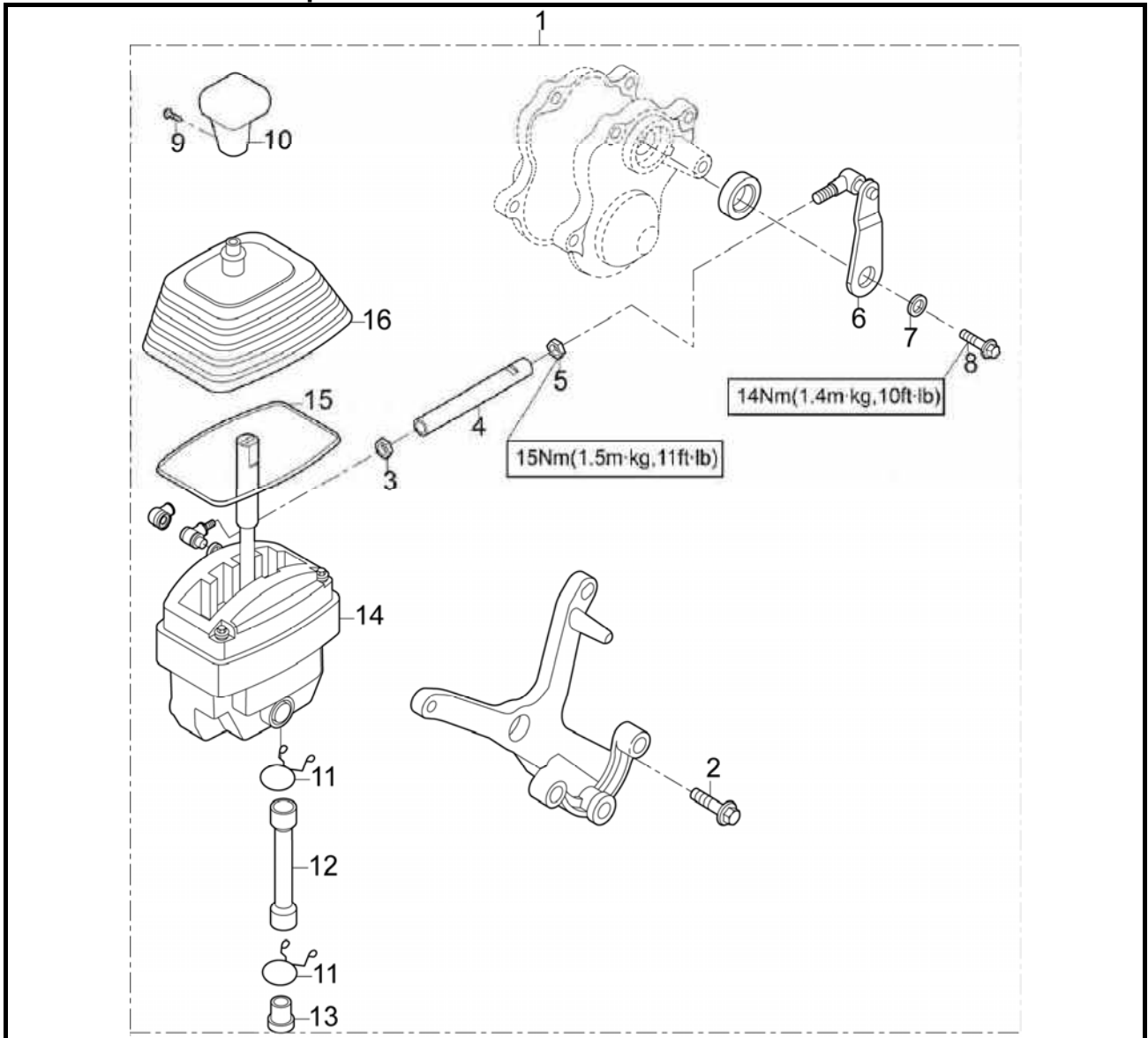

No.	Part Name	Qty	Remarks
	Removing the shift shaft		
1	Gear shifter assembly	1	
2	Hexagon flange bolt M8×20	3	
3	Hexagon nut M6	1	
4	Gear shift rod	1	
5	Hexagon nut M6	1	
6	Gearshift tie	1	
7	Washer Φ6×Φ18×1.5	1	
8	Hexagon flange bolt M6×12	1	
9	Plastic screw	1	
10	Gearshift knob	1	

CHASSIS

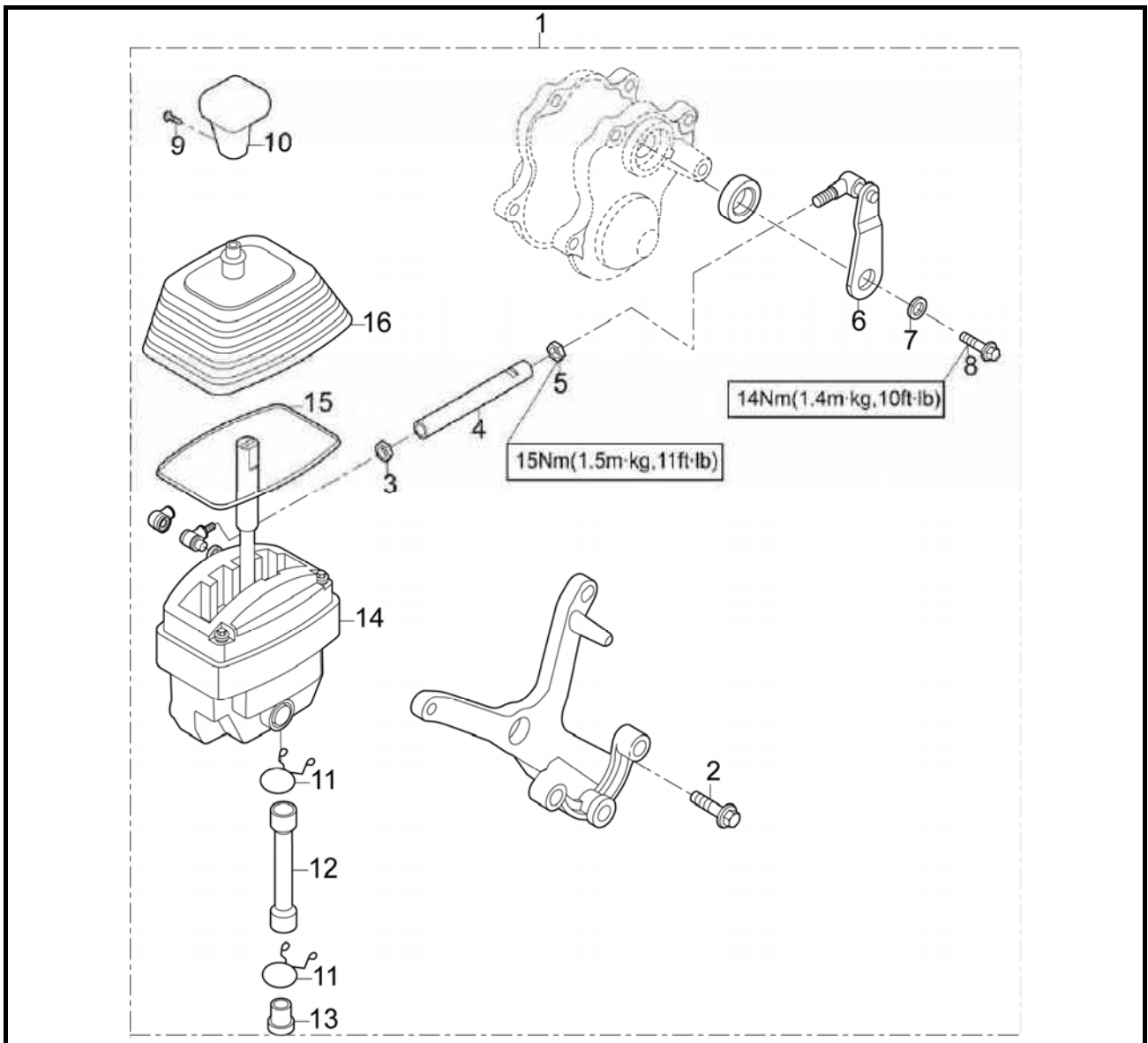

No.	Part Name	Qty	Remarks
11	Clip $\phi 14$	2	
12	Draining tube	1	
13	Plug	1	
14	Gearshift assy.	1	
15	Rubber cover clamp	1	
16	Gearshift boot	1	

CHASSIS

Reverse mechanism parts

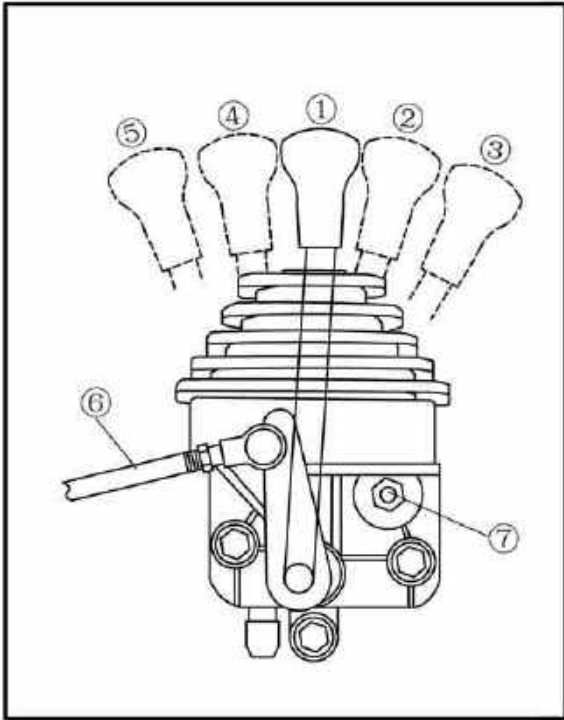

ADJUSTING REVERSE MECHANISM PARTS

- ① Neutral
- ② High
- ③ Low
- ④ Reverse
- ⑤ Parking
- ⑥ Select lever shift rod
- ⑦ Shift control cable

NOTE:

Before shifting, you must stop the vehicle and take your foot off the accelerator pedal. Otherwise, the transmission may be damaged.

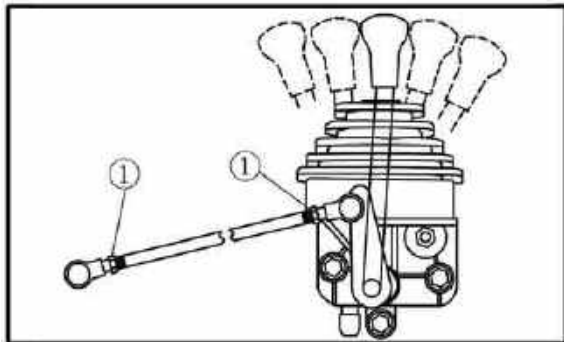

1. Adjust:

- Select lever shift rod
 - a. Make sure the select lever is in NEUTRAL.
 - b. Loosen both locknuts ①.

Note:

The select lever shift rod locknut (select lever side) has left-handed threads. To loosen the locknut, turn it clockwise.

- c. Adjust the shift rod length for smooth and correct shifting.
- d. Tighten the locknuts ①.

Locknut

15 Nm (1.5 m · kg, 11 ft · lb)

Reverse mechanism parts

CHECKING AND SERVICE OF REVERSE MECHANISM

1. Check the mobility of gear shift handle. If it is not working properly, remove the gear shift Mechanism to check if the fork , ball and spring is stuck.,in which case replace the defective component and try again.The last way is to turn to the professional repairman.
2. If there is lack in the gear shift mechanism , adjust the nut of the fork to correct position and strengthen gear shift mechanism .
3. Remove the gear shift mechanism and check whether the linking rod is cracked; If so, it should be changed.
4. Check whether the bouncing spring of gear shift mechanism is intense enough.
5. Check whether the gear is engaged correctly and whether there are tripstop or lack. If these situation exists, call for the maintanance staff to test and repair it.
6. If the gear can not be engaged, we can test it from the following aspects:
 - whether the clutch can completely declutch;
 - whether the gearshift is greased reliable(whether the oil pipe of gear shift mechanism is blocked);
 - whether gear shift mechanism jams;if these situation happens, maintanance staff would come to test and repair it.

CHASSIS

SUSPENSION

Front Suspension and arm

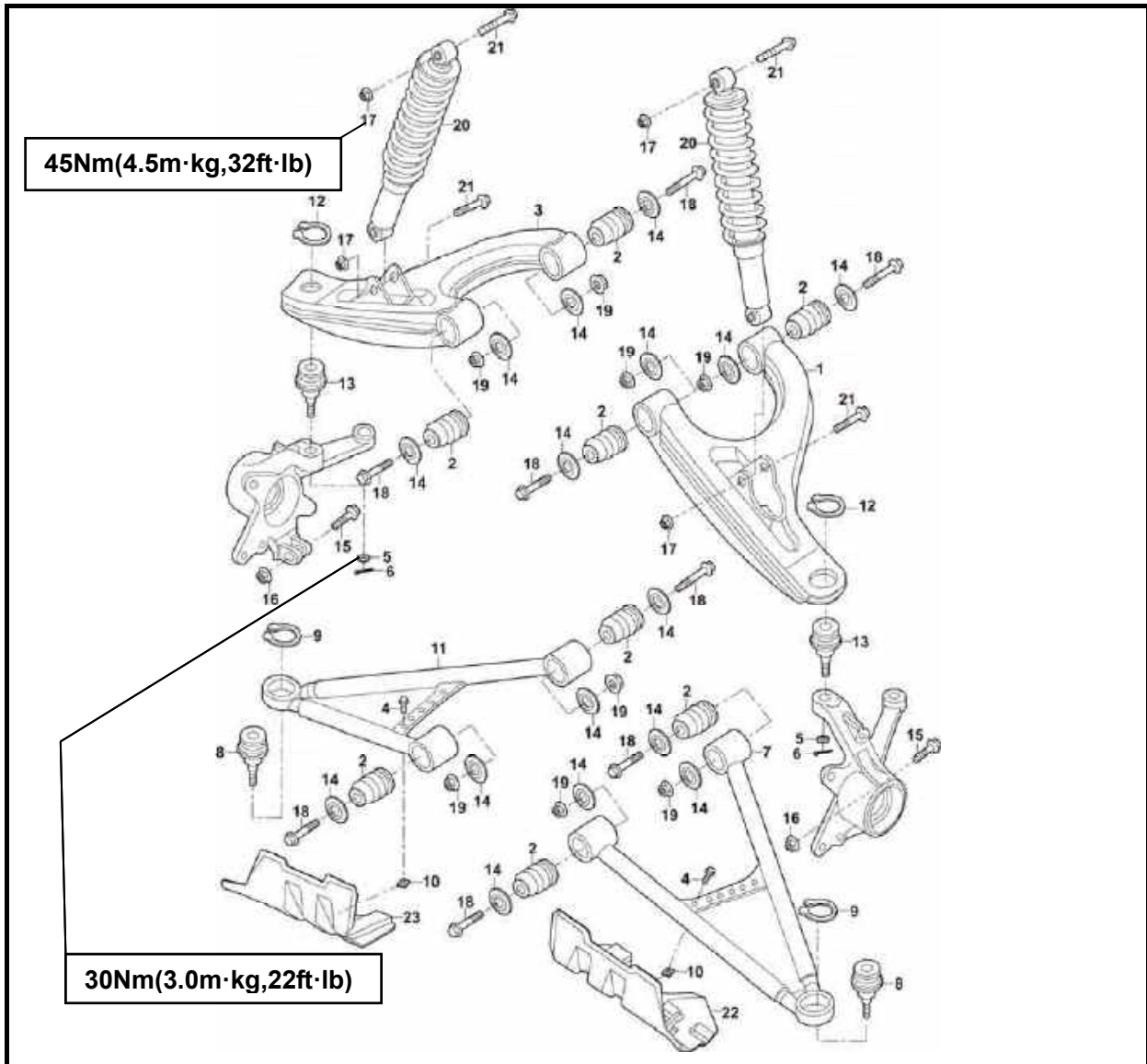

No.	Part Name	Qty	Remarks
	Removing the front suspension and arm		
1	Left front upper swing arm	1	
2	Middle rubber tube, swing arm	8	
3	Right front upper swing arm	1	
4	Hexagon flange bolt M6×12	2	
5	Hexagon bolt M10×1.25	2	
6	Cotter pin 2.5×40	2	
7	Left front lower swing arm	1	
8	Front lower ball joint	2	
9	Circlip d0=29	2	

CHASSIS

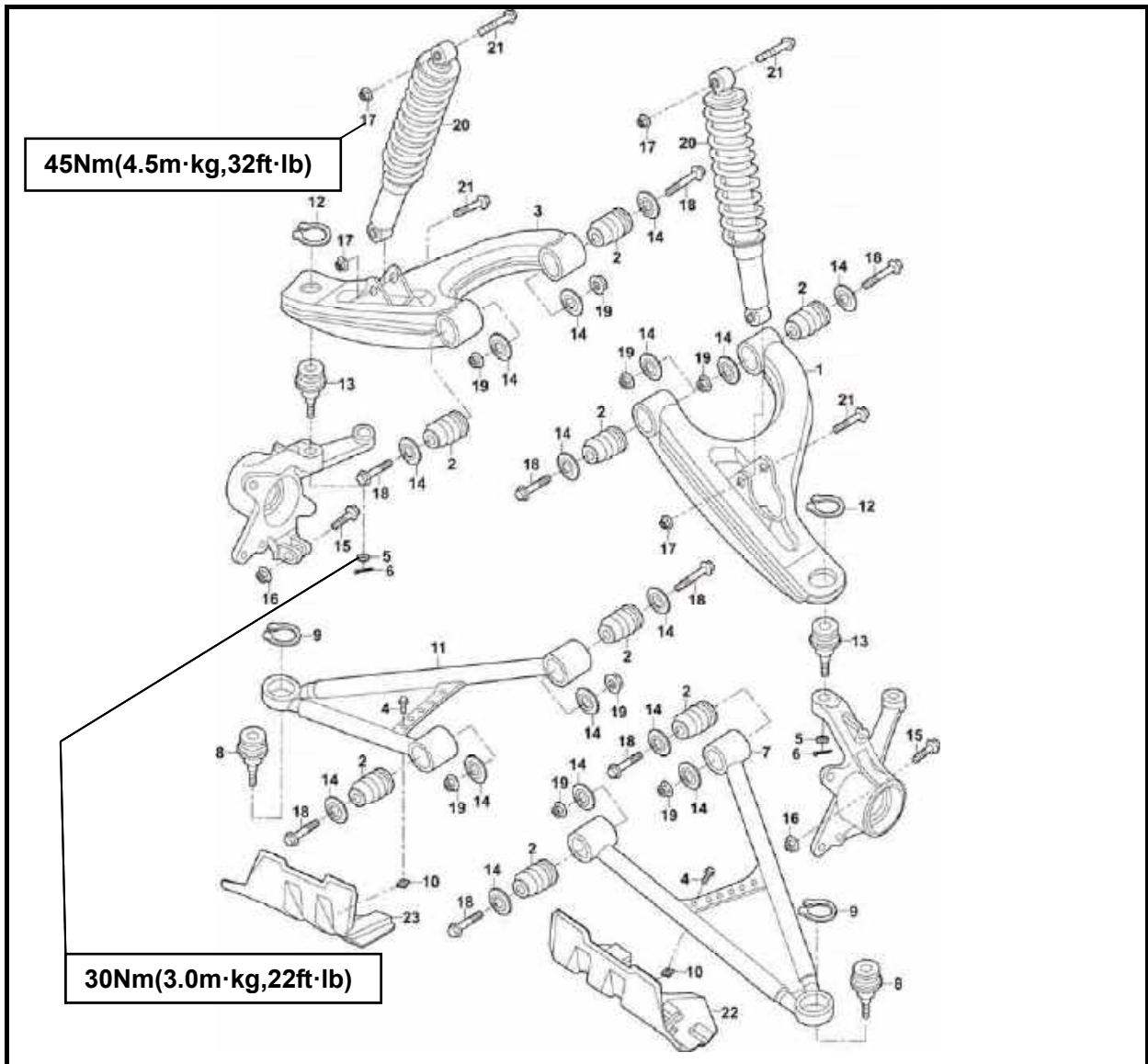

No.	Part Name	Qty	Remarks
10	Clip for bolt M6×2	2	
11	Right front lower swing arm	1	
12	Circlip d0=29	2	
13	Front upper ball joint	2	
14	Dust cover B	16	
15	Hexagon flange bolt M10×1.25×40	2	
16	Hexagon flange self-lock nuts M10×1.25	2	
17	Hexagon flange self-lock nuts M10×1.25	4	
18	Hexagon flange bolt M10×1.25×70	8	
19	Hexagon flange self-lock nuts M10×1.25	8	
20	Front shock absorber	2	

CHASSIS

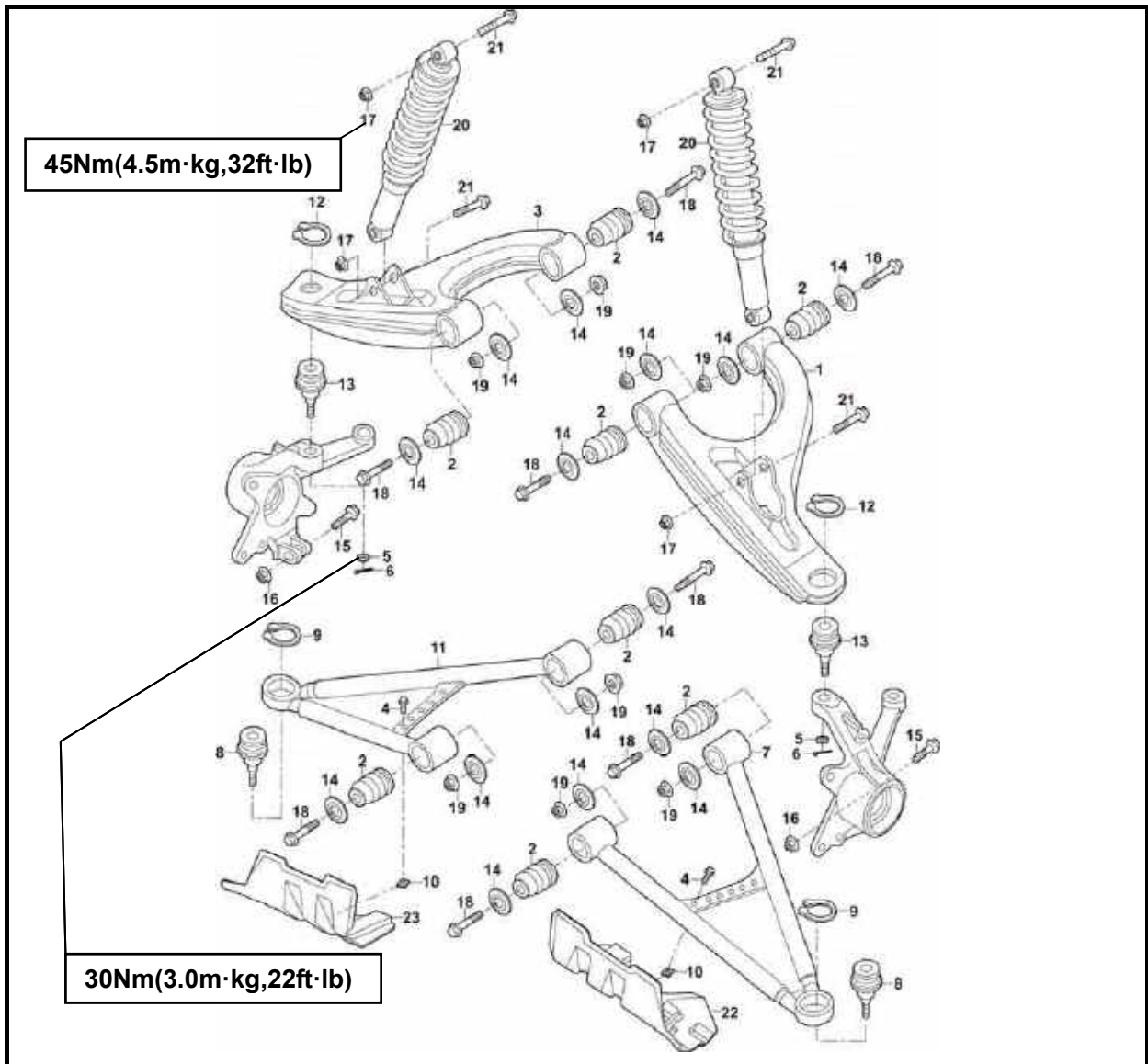

No.	Part Name	Qty	Remarks
21	Hexagon flange bolt M10×1.25×50	4	
22	Right front lower swing arm shield	1	
23	Left front lower swing arm shield	1	

Front Suspension and arm

DISASSEMBLING, SERVICE AND ASSEMBLY THE SUPPORTING ROCKER PARTS

1. Disassembling and Service

In the suspension, there is easy to appear the problem with bushing, cotter pin and shock absorber.

- If the left and right rocker rocks fiercely, check the few aspect, whether the bushing of the rocker is crushed, the middle rubber separate is aging and chapped.

- check whether the cotter pin is credible, if it is not instead the same spec cotter pin.

- The problem with the shock absorber and maintain method, whether it can returns to the position under the pressure and the torsional spring is rupture. If it is rupture or nearly to rupture, instead the shock absorber. whether it leak oil, if so instead the same spec shock absorber. According to the different request, if there is a oil cup on the rocker, must check it whether complete and refuels.

2. Install:

Mount fore L/R damper,up-and-down rocker arm assembly onto the frame with Hexagon Flange Bolt M10 × 65 (8pcs), M10 nuts (8pcs), Hexagon Flange Bolt M10 × 50 (4pcs) and M10 locknuts (4pcs) to ensure a torque of 40 ~ 45Nm.

CAUTION:

- **These components should be greased with butter before assembly.**
 - **The surface of components can not be cracked.**
-

CHASSIS

Front Suspension and arm

- Check whether these components are greased with butter and then tighten the up-and-down rocker arm assembly and L/R fore dampers and their components. Fix the L/R tension rods into hole by way of the trough of open-groove nut with cotter pin (4 pcs), and make these tension rods bisection on feet.

CHECKING THE FRONT ARMS

1. Check:
 - front arms
Bends/damage → Replace.
2. Check:
 - Middle bushing
Wear/damage → Replace.
3. Check:
 - ball joints
Damage/pitting → Replace the ball joint.
Free play → Replace the ball joint.
Turns roughly → Replace the ball joint.

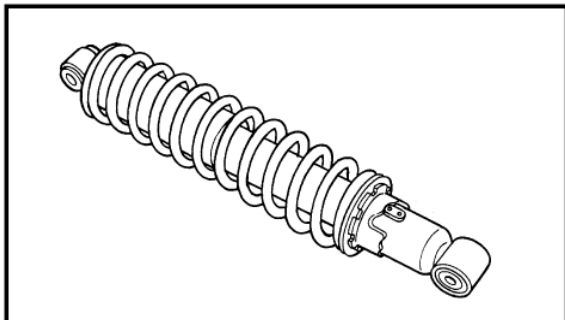

CHECKING THE FRONT SHOCK ABSORBER

1. Check:
 - shock absorber rod
Bends/damage → Replace the shock absorber assembly.
 - shock absorber assembly
Oil leaks → Replace the shock absorber assembly.
 - spring
Fatigue → Replace the shock absorber assembly.
Move the spring up and down.

CHASSIS

Front Suspension and arm

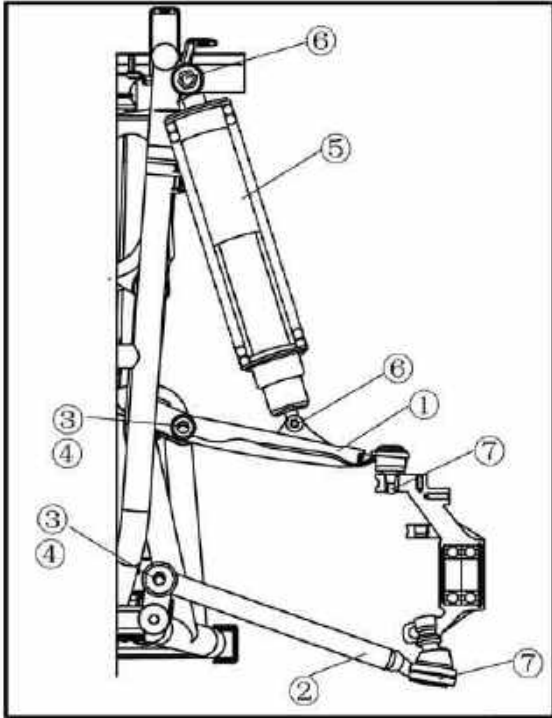

INSTALLING THE FRONT ARMS AND FRONT SHOCK ABSORBER

1. Install:

- front arms
- front shock absorber

a. Install the front upper arm ① and front lower arm ②.

NOTE:

- Lubricate the bolts ③ with lithium-soap-based grease.
- Be sure to position the bolts ③ so that the bolt head faces outward.
- Temporarily tighten the nuts ④.

b. Install the front shock absorber ⑤.

Nut ⑥

45 Nm (4.5 m · kg, 32 ft · lb)

c. Install the ball joints.

Nut ⑦

30 Nm (3.0 m · kg, 22 ft · lb)

d. Install the new cotter pins.

e. Tighten the nuts.

Nut ④

45 Nm (4.5 m · kg, 32 ft · lb)

CHASSIS

Rear Suspension

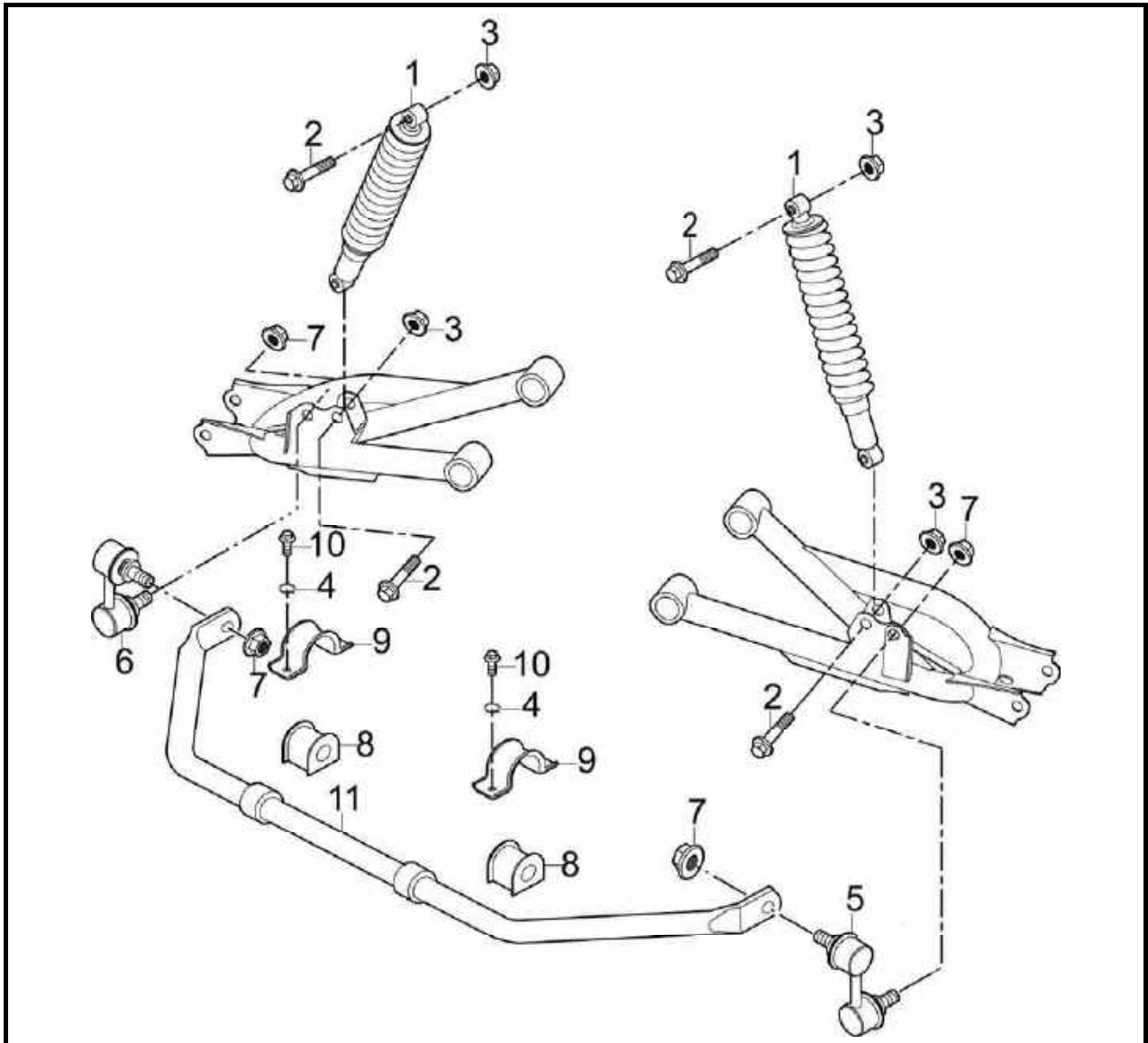

No.	Part Name	Qty	Remarks
	Removing the rear suspension		
1	Rear shock absorber	2	
2	Hexagon flange bolt M10×1.25×50	4	
3	Hexagon flange nut M10	4	
4	Spring washer -8	4	
5	Right tie-rod, anti-roll bar	1	
6	Left tie-rod, anti-roll bar	1	
7	Hexagon flange self-lock nuts M10×1.25	4	
8	U type rubber bush II	2	
9	Press block, rear anti-roll bar	2	
10	Hexagon flange bolt M8×16	4	
11	Rear anti-roll bar	1	

CHASSIS

Rear arm shaft

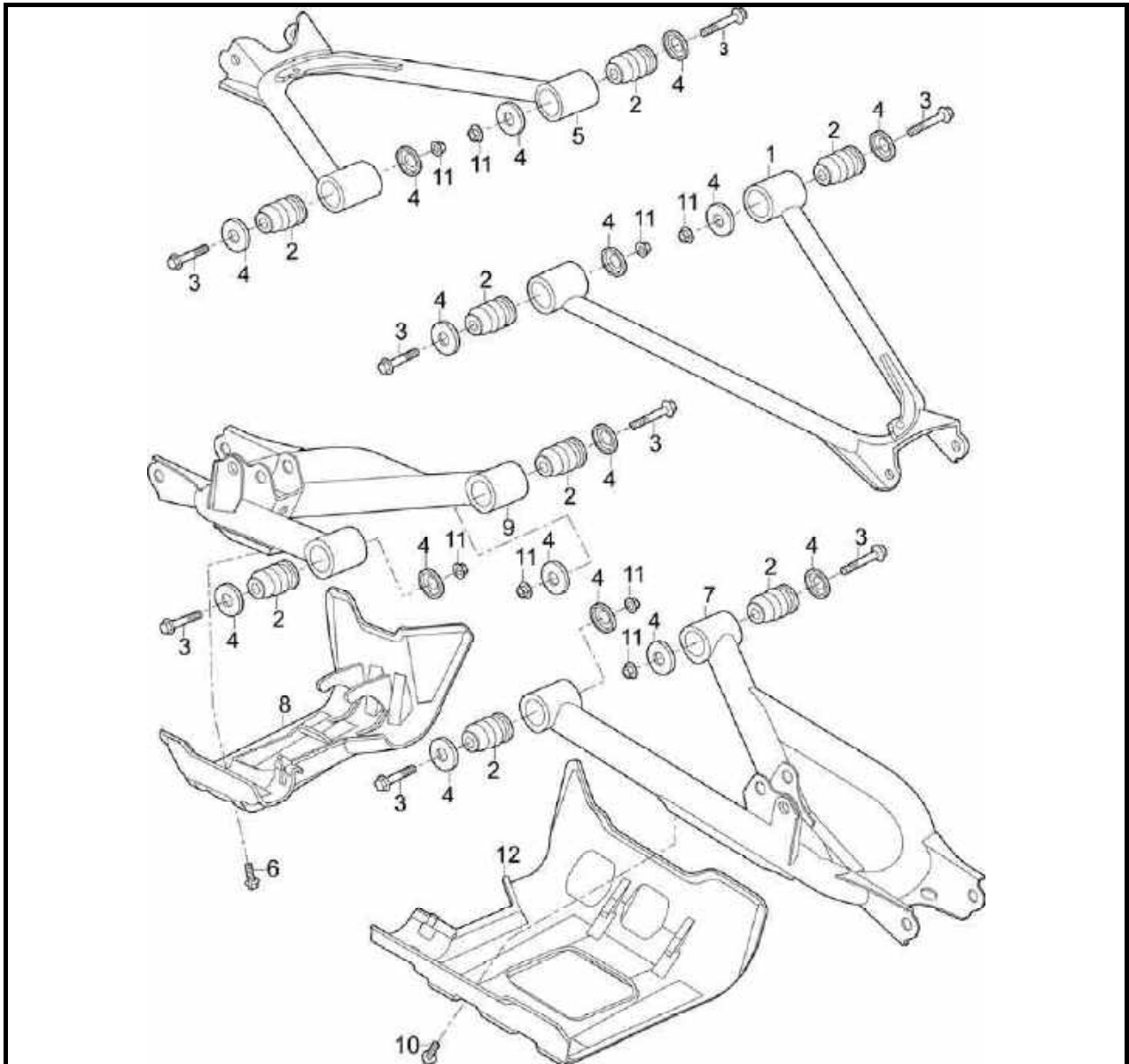

No.	Part Name	Qty	Remarks
	Removing the rear arm shaft		
1	Rear left upper swing arm	1	
2	Middle rubber tube, swing arm	8	
3	Hexagon flange bolt M10×1.25×70	8	
4	Dust cover B	16	
5	Rear right upper swing arm	1	
6	Hexagon flange bolt M6×12	2	
7	Rear left lower swing arm	1	
8	Rear right lower swing arm shield	1	
9	Rear right lower swing arm	1	

CHASSIS

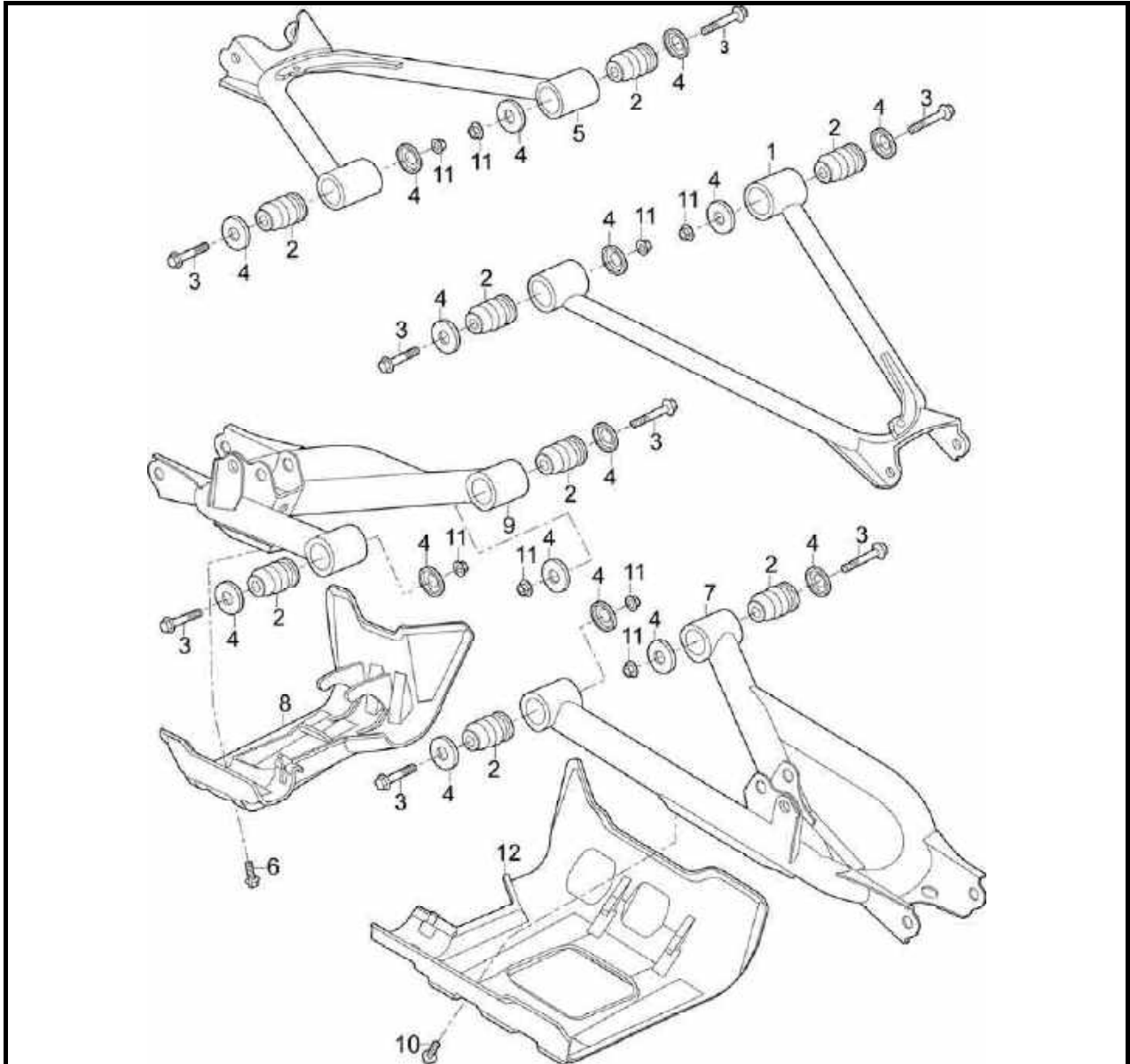

No.	Part Name	Qty	Remarks
10	Hexagon flange bolt M6×12	2	
11	Hexagon flange self-lock nuts M10×1.25	8	
12	Rear left lower swing arm shield	1	

CHASSIS

Rear Suspension and arm

CHECKING AND SERVICE OF REAR SUSPENSION

1. It is similar to the front suspension ,Check if there exists any distortion or crack on the install axis of the shock absorber in which case it must be replaced.
2. Inspect the rocker bushing and the middle rubber separate is integrant.(According to the front Suspension)
3. The cotter pin on the head of the install axis which in the rear shock absorber whether is credible.

NOTE: _____
After disassemble the rear shock absorber, check if there exists any distortion or crack on the frame connection hole and the rear shock absorber, if so, inform the special serviceman to inspect and service first or install the rear shock absorber on the frame after instead.(Attention, the bolts must be the special self-lock nut, the fastening torque must be 45-55Nm)

CHASSIS

Rear Suspension and arm

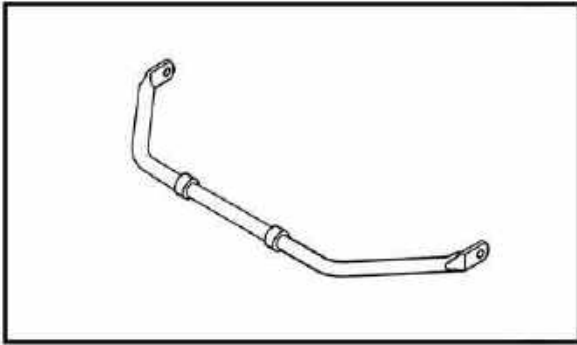

CHECKING THE STABILIZER

1. Check:
 - bar, stabilizerBends/cracks/damage → Replace.

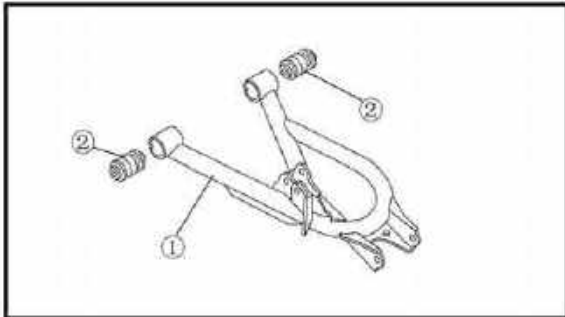

CHECKING THE REAR ARMS

1. Check:
 - rear arms ①Bends/damage → Replace.
2. Check:
 - Middle bushing ②Wear/damage → Replace.

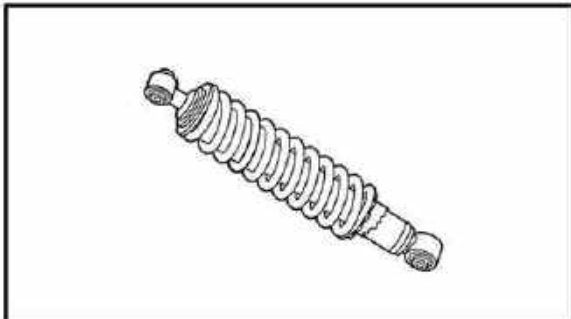

CHECKING THE REAR SHOCK ABSORBER

1. Check:
 - shock absorber rod
 - Bends/damage → Replace the shock absorber assembly.
 - shock absorber assembly
 - Oil leaks → Replace the shock absorber assembly.
 - spring
 - Move the spring up and down.
 - Fatigue → Replace the shock absorber assembly.

CHASSIS

INSTALLING THE REAR ARMS AND REAR SHOCK ABSORBER

1. Install:

- rear arms
- rear shock absorber

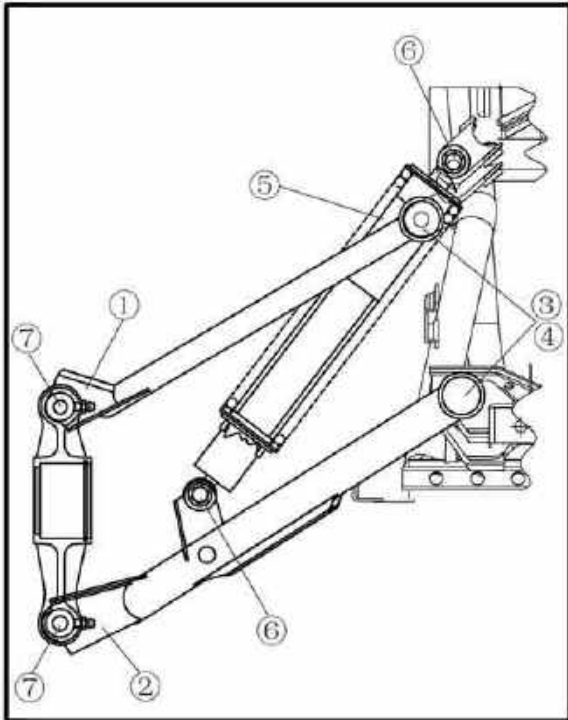

a. Install the rear upper arm ① and rear lower arm ②.

NOTE:

- Lubricate the bolts ③ with lithium-soap-based grease.
- Be sure to position the bolts ③ so that the bolt head faces inward.
- Temporarily tighten the nuts ④.

b. Install the rear shock absorber ⑤.

Nut ⑥

45 Nm (4.5 m · kg, 32 ft · lb)

c. Install the rear knuckle.

Nut ⑦

45 Nm (4.5 m · kg, 32 ft · lb)

d. Tighten the nuts ④.

Nut ④

45 Nm (4.5 m · kg, 32 ft · lb)

CHASSIS

COOLING SYSTEM

RADIATOR

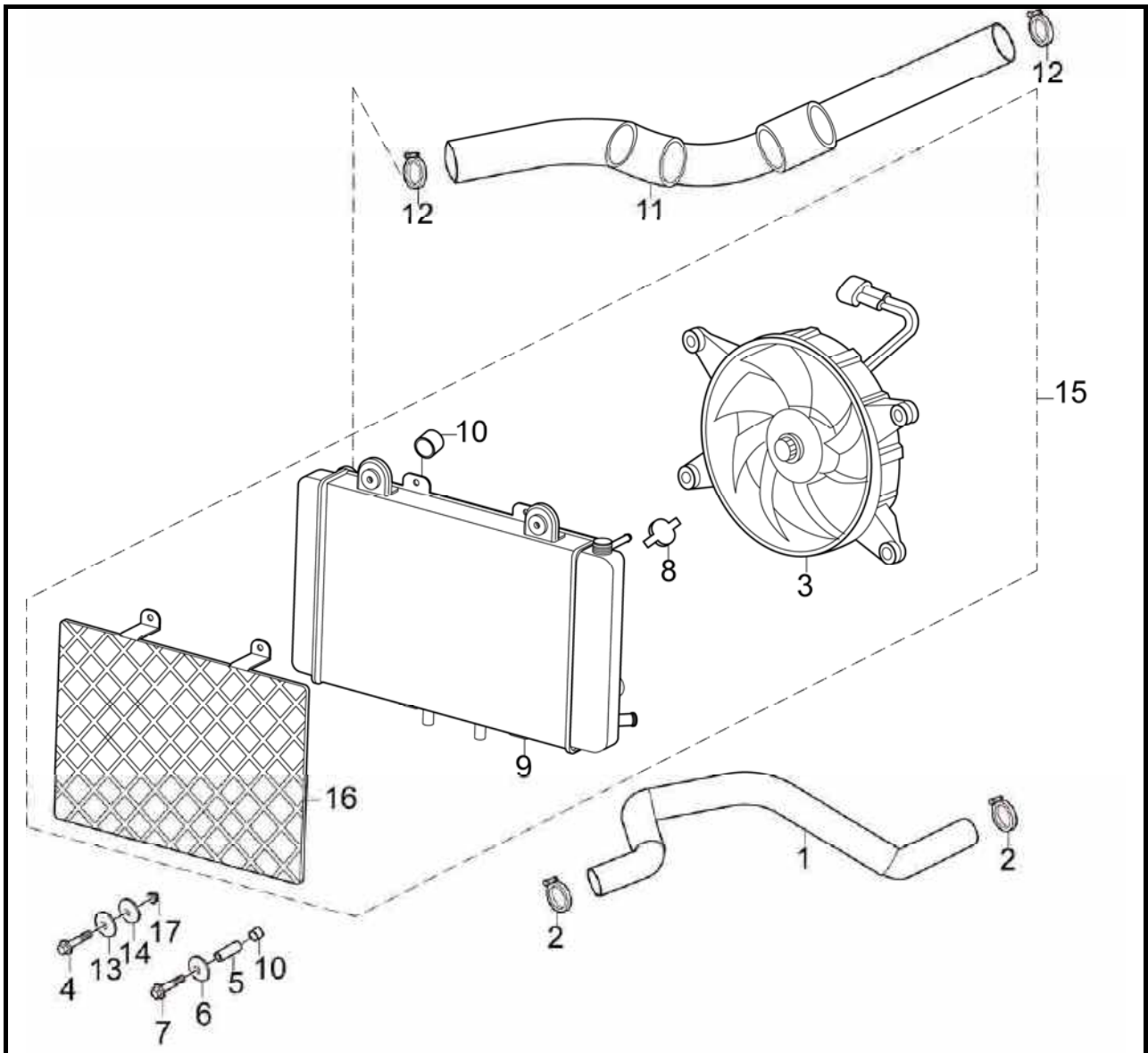

No.	Part Name	Qty	Remarks
	Removing the radiator		
1	Water pipe (L)	1	
2	Screw hoop $\Phi 20-32$	2	
3	Water-tank fan assy	1	
4	Full thread tex head bolt $M6 \times 16$	4	
5	Bush	2	
6	Washer $\Phi 6 \times \Phi 18 \times 1.5$	2	
7	Hexagon Flange Bolt $M6 \times 20$	2	
8	Water tank cover	1	
9	Water tank comp	1	

CHASSIS

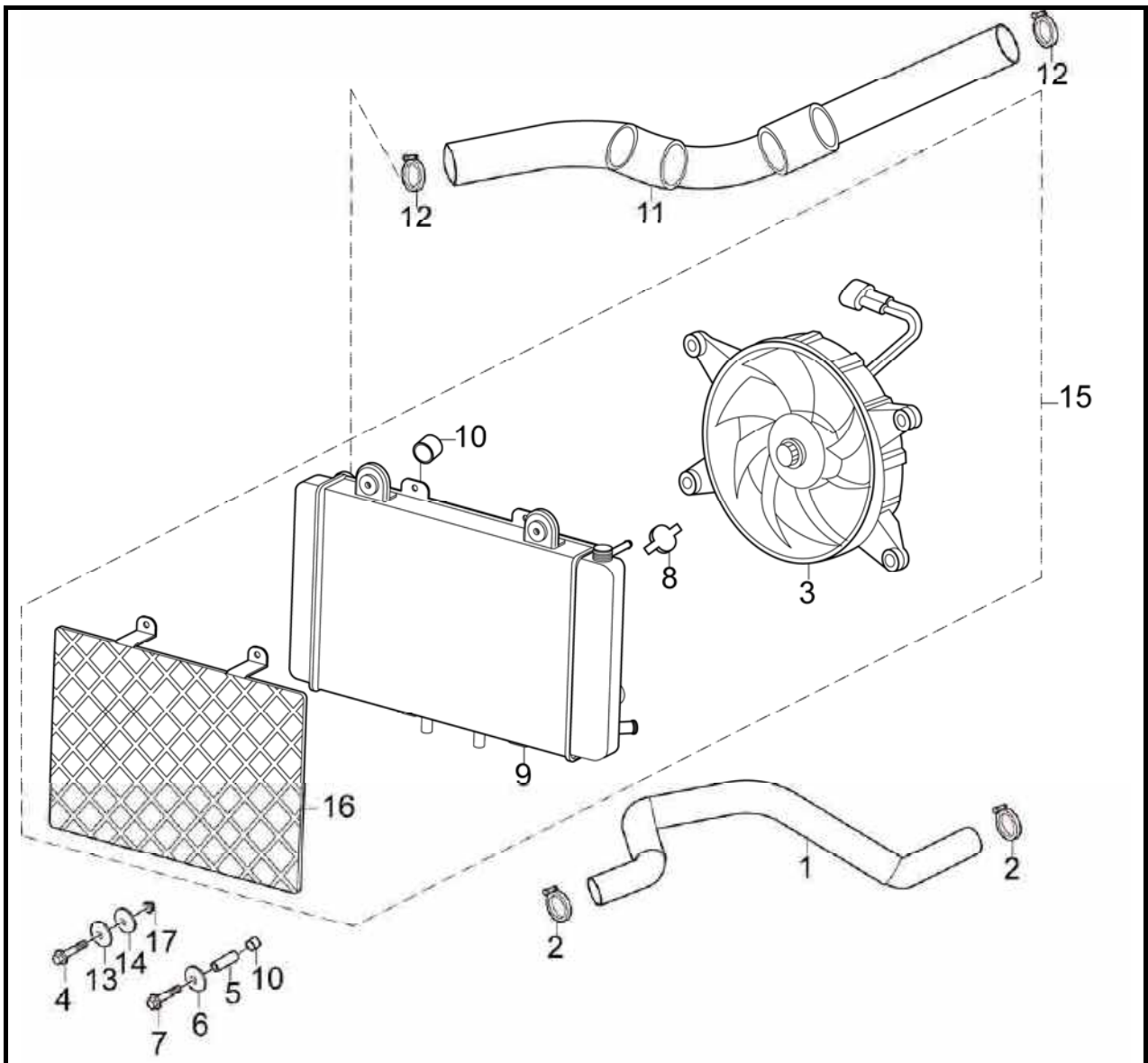

No.	Part Name	Qty	Remarks
10	H style rubber ring	4	
11	Water pipe R	1	
12	Screw hoop $\Phi 20-32$	2	
13	Spring washer -6	4	
14	Washer $\Phi 6 \times \Phi 16 \times 1.5$	4	
15	Cooler, water-tank	1	
16	Water cooling radiator cover	1	
17	Hexagon flange nut M6	4	

CHASSIS

RADIATOR

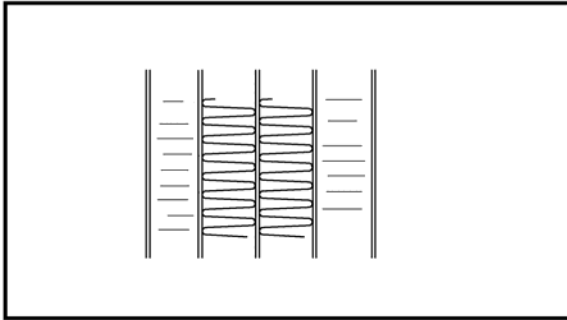

CHECKING THE RADIATOR

1. Check:

- radiator fins

Obstruction → Clean.

Apply compressed air to the rear of the radiator

Damage → Repair or replace.

NOTE: _____

Straighten any flattened fins with a thin, flat-head screwdriver.

2. Check:

- all rubber hose

Cracks/damage → Replace.

3. Check:

- Bolt clip

the tightness of Bolt clip. If loosen, please have the hoop tightened immediately.

4. Check:

- radiator fan

Damage → Replace.

Malfunction → Check and repair.

5. Measure:

- radiator cap opening pressure

Below the specified pressure → Replace the radiator cap.

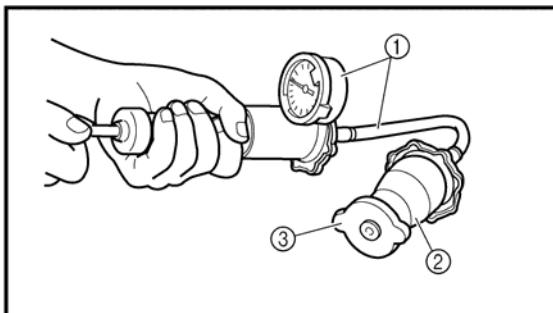

Radiator cap opening pressure

107.9 ~ 137.3 KPa

(1.079 ~ 1.373 kg/cm², 15.35 ~ 19.53 psi)

a. Install the radiator cap tester ① and adapter

② onto the radiator cap ③.

b. Apply the specified pressure for ten sec-onds and make sure that there is no drop in pressure.

4. Check:

INSTALLING THE RADIATOR

1. Fill:

- cooling system

Start engine when pour full the refrigerating fluid, loose the exhaust nut on the pipe, the water level will get lower at this time, Supply the refrigerating fluid until the water level stop to change, then screw the exhaust nut, cover the water tank lid. The water tank inspection is finished. .

2. Check:

- cooling system

Leaks → Repair or replace any faulty part.

CHASSIS

WATER PUMP

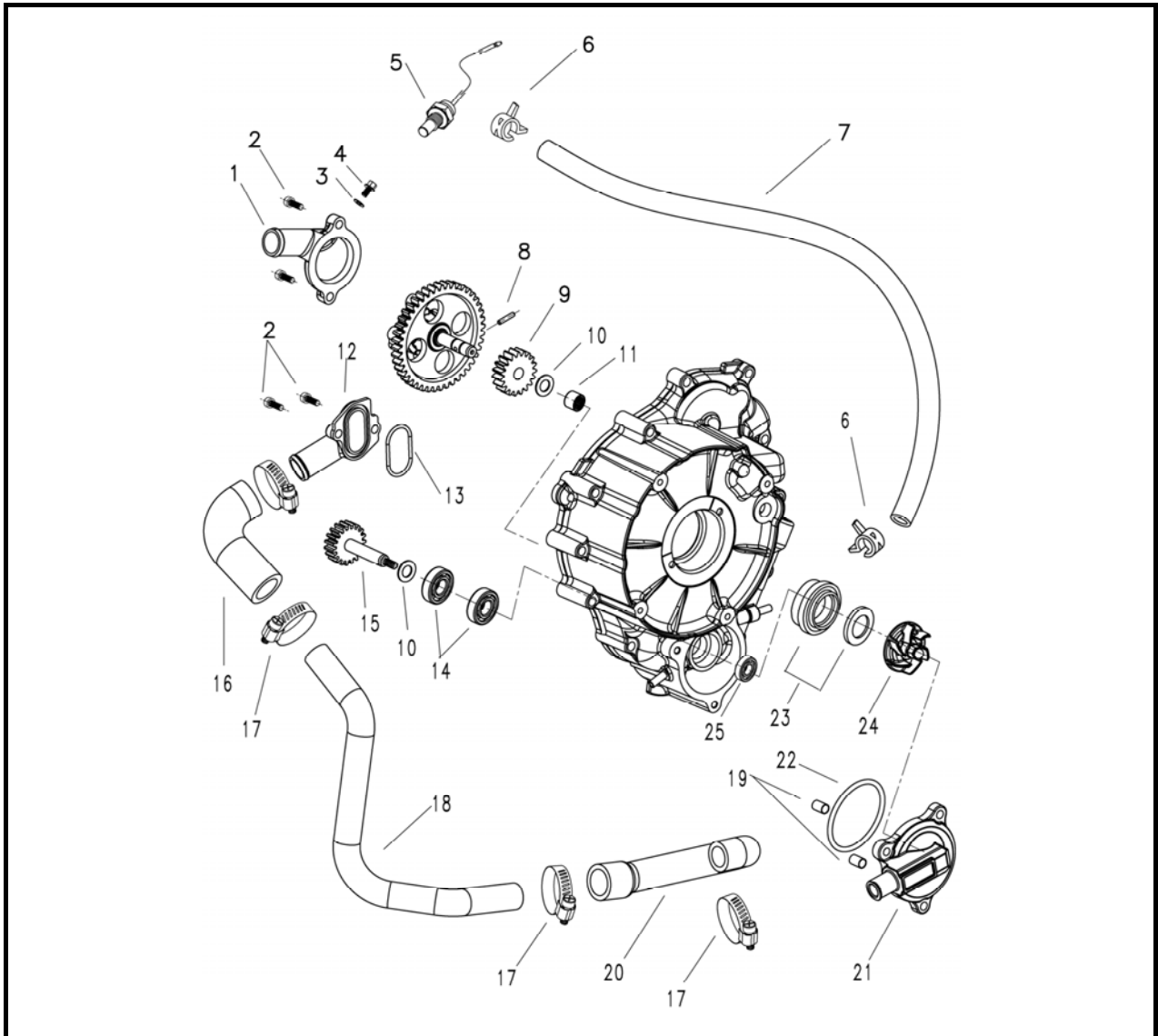

No.	Part Name	Qty	Remarks
	Removing the water pump		
1	Save temperature cover	1	
2	Hex flange bolt M6×20	2	
3	Washer 6×13×1.5	1	
4	Hex flange bolt M6×14	1	
5	Water temperature sensor	1	
6	Clip II	2	
7	Water pipe I	1	
8	Pin	1	
9	Gear, water pump	1	
10	Washer 10×1	2	
11	Bearing 1010	1	
12	Cylinder inlet water joint	1	

CHASSIS

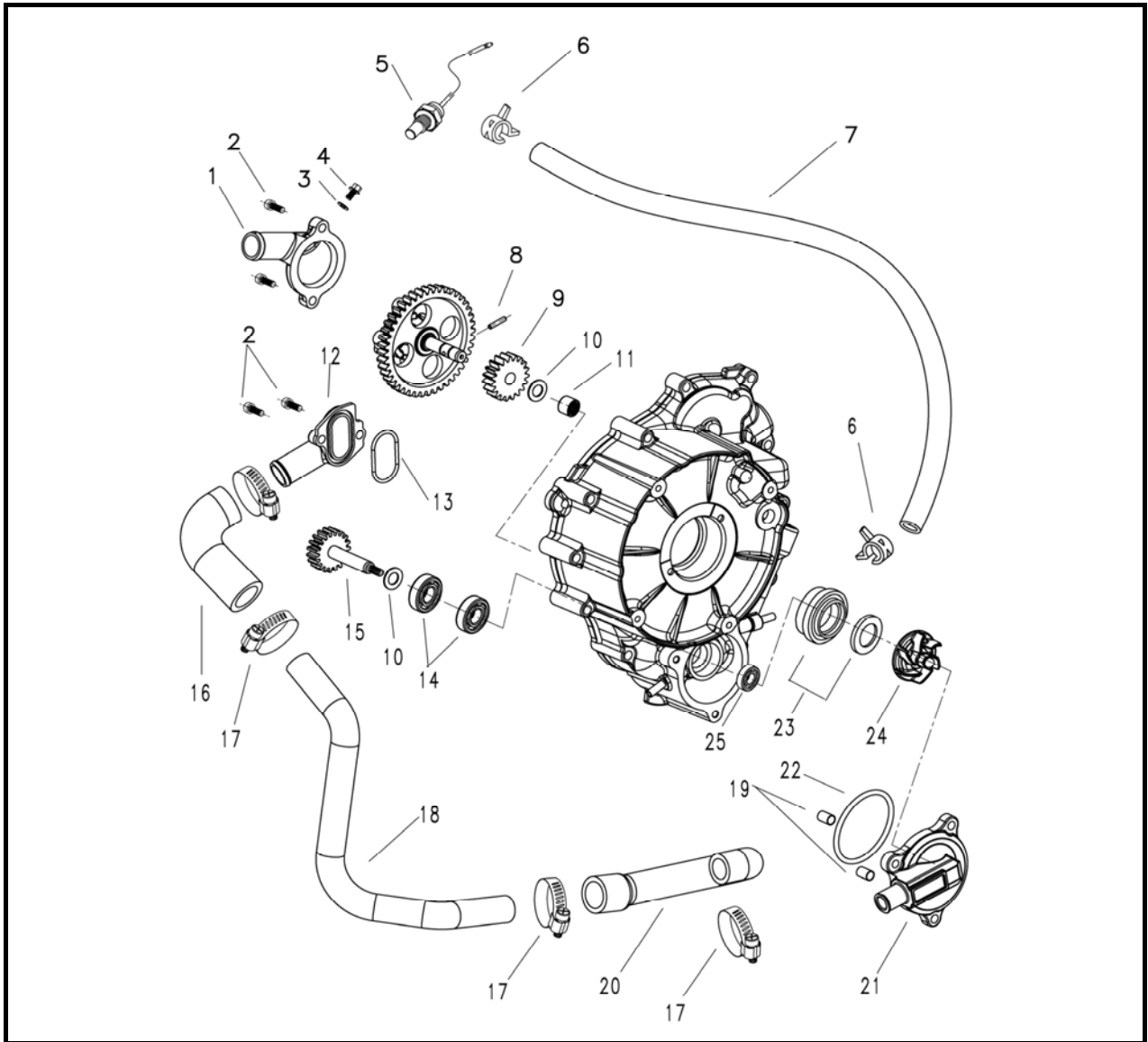

No.	Part Name	Qty	Remarks
13	O-ring 33.4×2.4	1	
14	Bearing 6000	2	
15	Gear, water pump	1	
16	water pipe-1	1	
17	water pipe clip	4	
18	water pipe-3	1	
19	Pin $\Phi 8 \times 11.8$	2	
20	water pipe--2	1	
21	Cover, water pump	1	
22	O-ring 50×2.5	1	
23	Water seal	1	
24	Vane wheel	1	
25	Oil seal 10×20×5	1	

CHASSIS

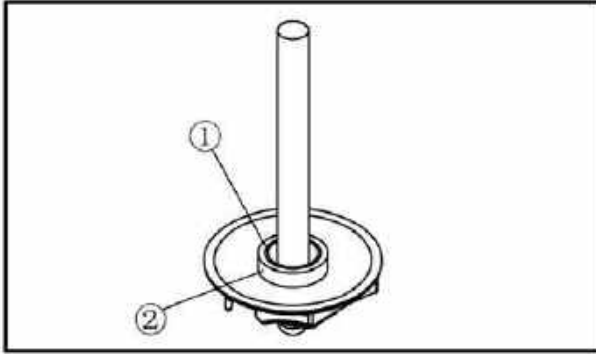

DISASSEMBLING THE WATER PUMP

1. Remove:

- rubber damper holder ①
- rubber damper ②

NOTE:

Do not scratch the impeller shaft.

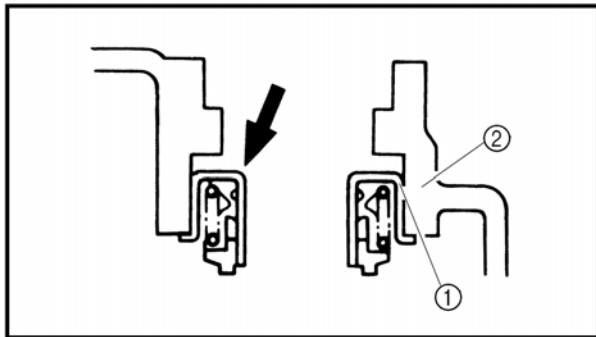

2. Remove:

- water pump seal ①
- Water pump housing ②

NOTE:

Tap out the water pump seal from the inside of the water pump housing.

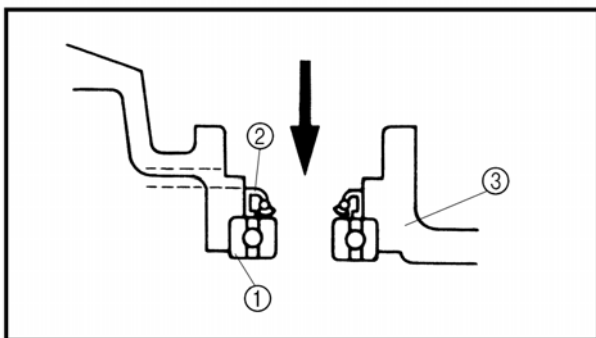

3. Remove:

- bearing ①
- oil seal ②
- water pump housing ③

NOTE:

- Tap out the bearing and oil seal from the outside of the water pump housing.
- Apply lithium-soap-based grease to the oil seal and apply engine oil to the bearing.

CHASSIS

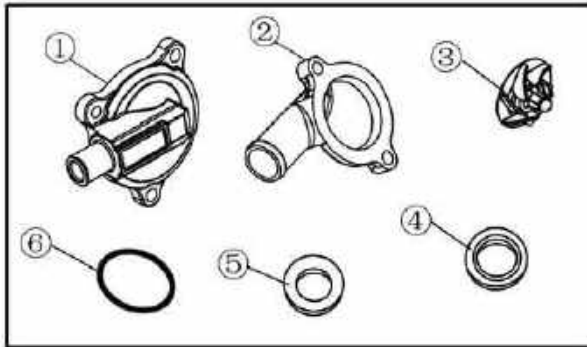

CHECKING THE WATER PUMP

1. Check:

- water pump housing cover ①
 - water pump housing ②
 - impeller ③
 - rubber damper ④
 - rubber damper holder ⑤
 - o-ring ⑥
- Cracks/damage/wear → Replace.

NOTE:

Apply lithium-soap-based grease to the o-ring.

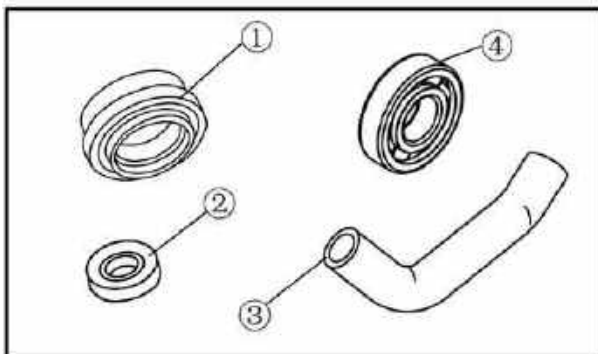

2. Check:

- water pump seal ①
 - oil seal ②
 - water pipe ③
- Cracks/damage/wear → Replace.
- bearing ④
- Rough movement → Replace.

NOTE:

Apply lithium-soap-based grease to the oil seal and apply engine oil to the bearing

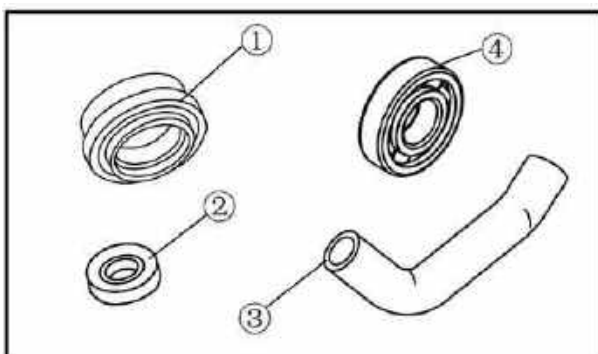

3. Measure:

- impeller shaft tilt
- Straightedge ①
Impeller ②
- Out of specification → Replace.

**Max. impeller shaft tilt
0.15 mm (0.006 in)**

CHASSIS

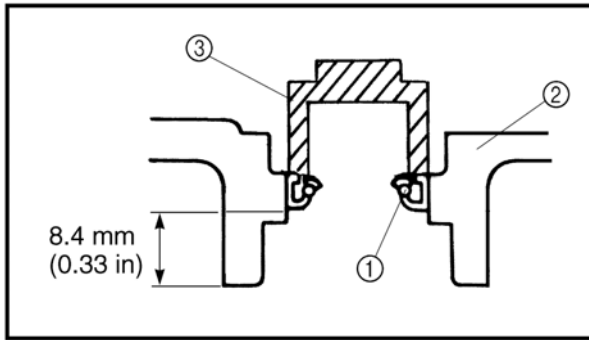

ASSEMBLING THE WATER PUMP

1. Install:

- oil seal ①
(into the water pump housing ②)

NOTE:

- Before installing the oil seal, apply tap water or coolant onto its outer surface.
- Install the oil seal with a socket ③ that matches its outside diameter.

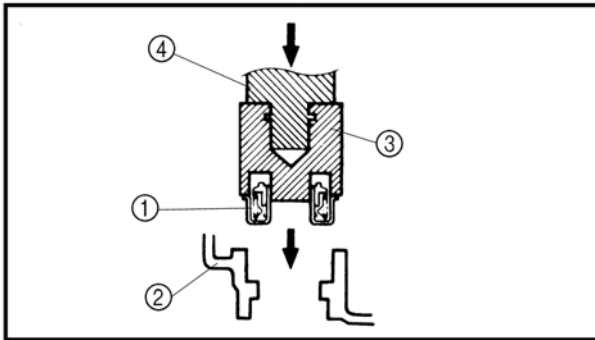

2. Install:

- water pump seal ①
(into the water pump housing ②)
- mechanical seal installer and water pump seal installer ③
- water pump seal installer ④

NOTE:

- Never lubricate the water pump seal surface with oil or grease.
- Install the water pump seal with the special tools.

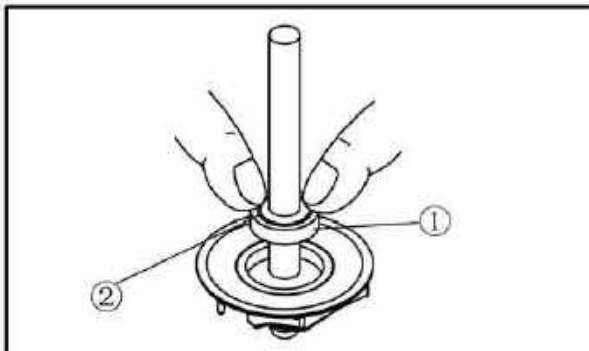

3. Install:

- rubber damper ①
- rubber damper holder ②

NOTE:

- Before installing the rubber damper, apply tap water or coolant onto its outer surface.
- Make sure that the rubber damper and rubber damper holder are flush with the impeller.

CHASSIS

SEAT

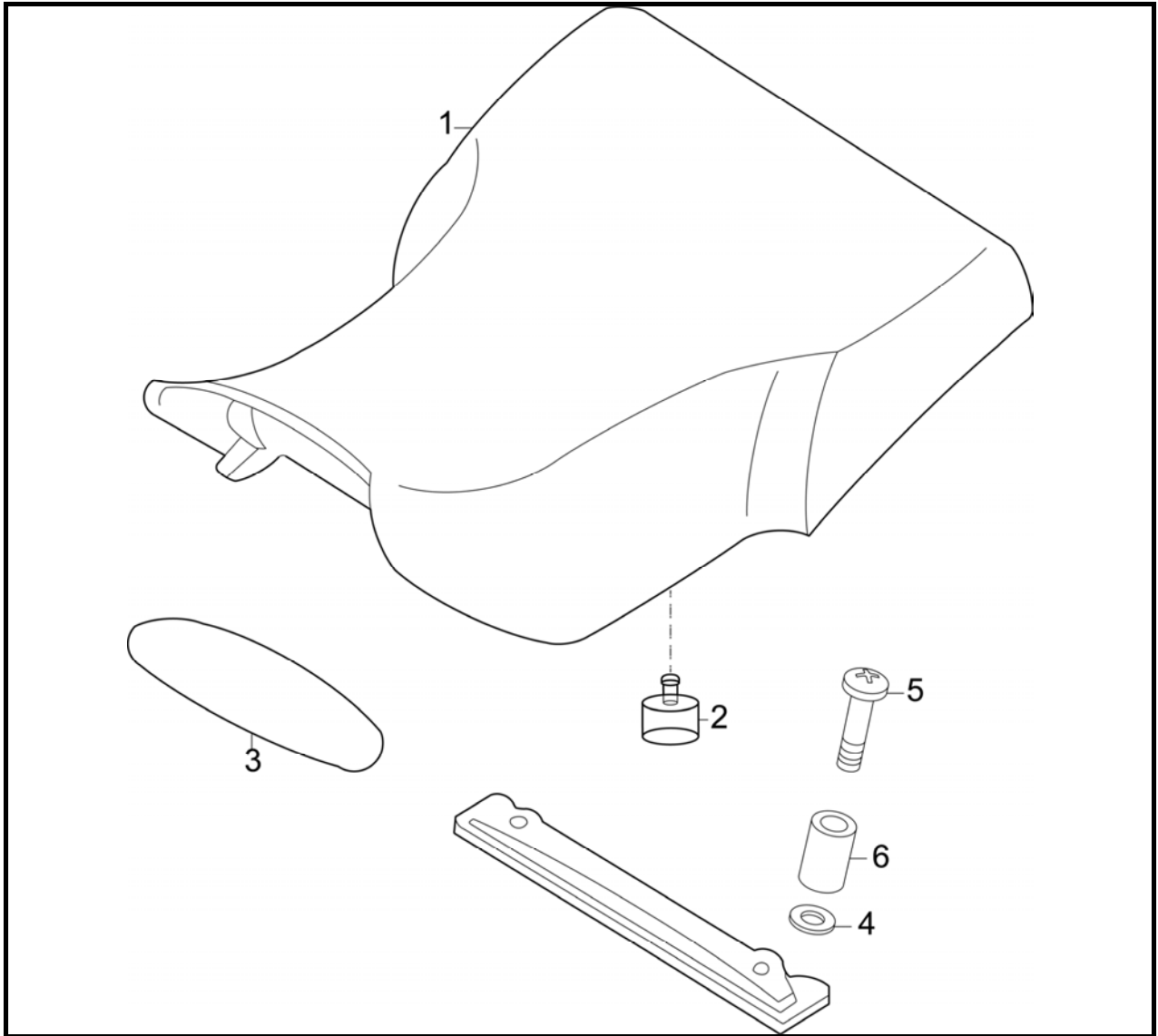

No.	Part Name	Qty	Remarks
	Removing the seat		
1	Seat	1	
2	Rubber cushion	6	
3	Heat insulation paper X	1	
4	Washer $\Phi 6 \times \Phi 18 \times 1.5$	2	
5	Cross large plate head screw M6×25	2	
6	Cylindrical rubber cushion	2	

CHASSIS

DISASSEMBLING THE SEAT

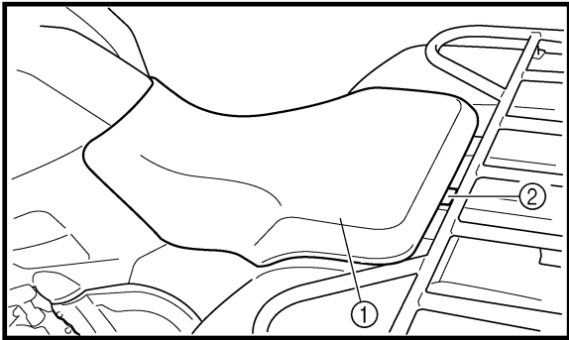

Remove:

- seat ①
- seat lock lever ②

To remove the seat, pull the seat lock lever upward and pull up the seat at the rear.

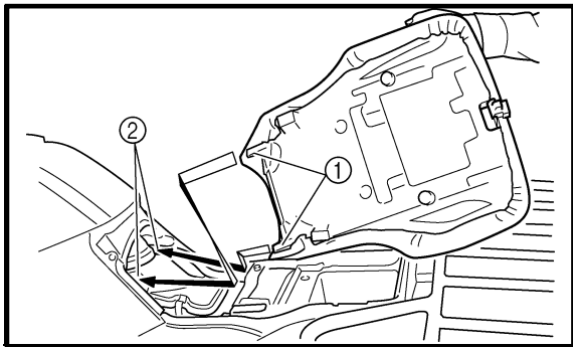

Install:

- Projection ①
- Seat holder ②

To install the seat, insert the projections on the front of the seat into the seat holders and push down on the seat at the rear.

NOTE: _____

- **Make sure that the seat is securely fitted.**
-

CHASSIS

FUEL TANK

FUEL TANK COVER PARTS

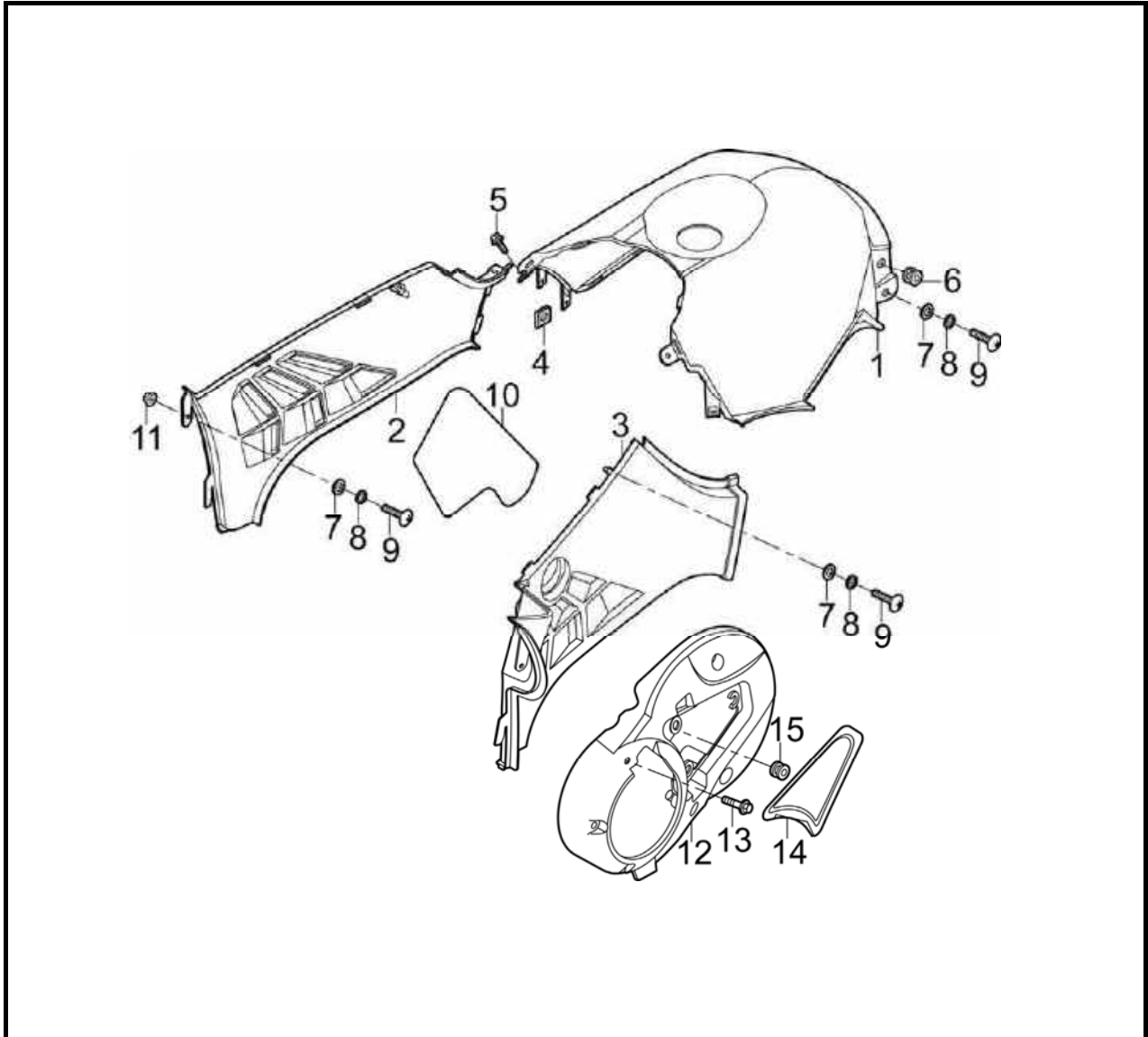

No.	Part Name	Qty	Remarks
	Removing the fuel tank cover parts		
1	Fuel tank cover	1	
2	Left shield, fuel tank	1	
3	Right shield, fuel tank	1	
4	Clip for bolt M6x2	4	
5	Hexagon step bolt M6x16-Φ10x4	2	
6	H style rubber ring	2	
7	Rubber washer Φ7xΦ20x2.5	16	
8	Washer Φ6xΦ18x1.5	16	
9	Cross large plate head screw M6x20	16	
10	Heat insulation paper XI	1	

CHASSIS

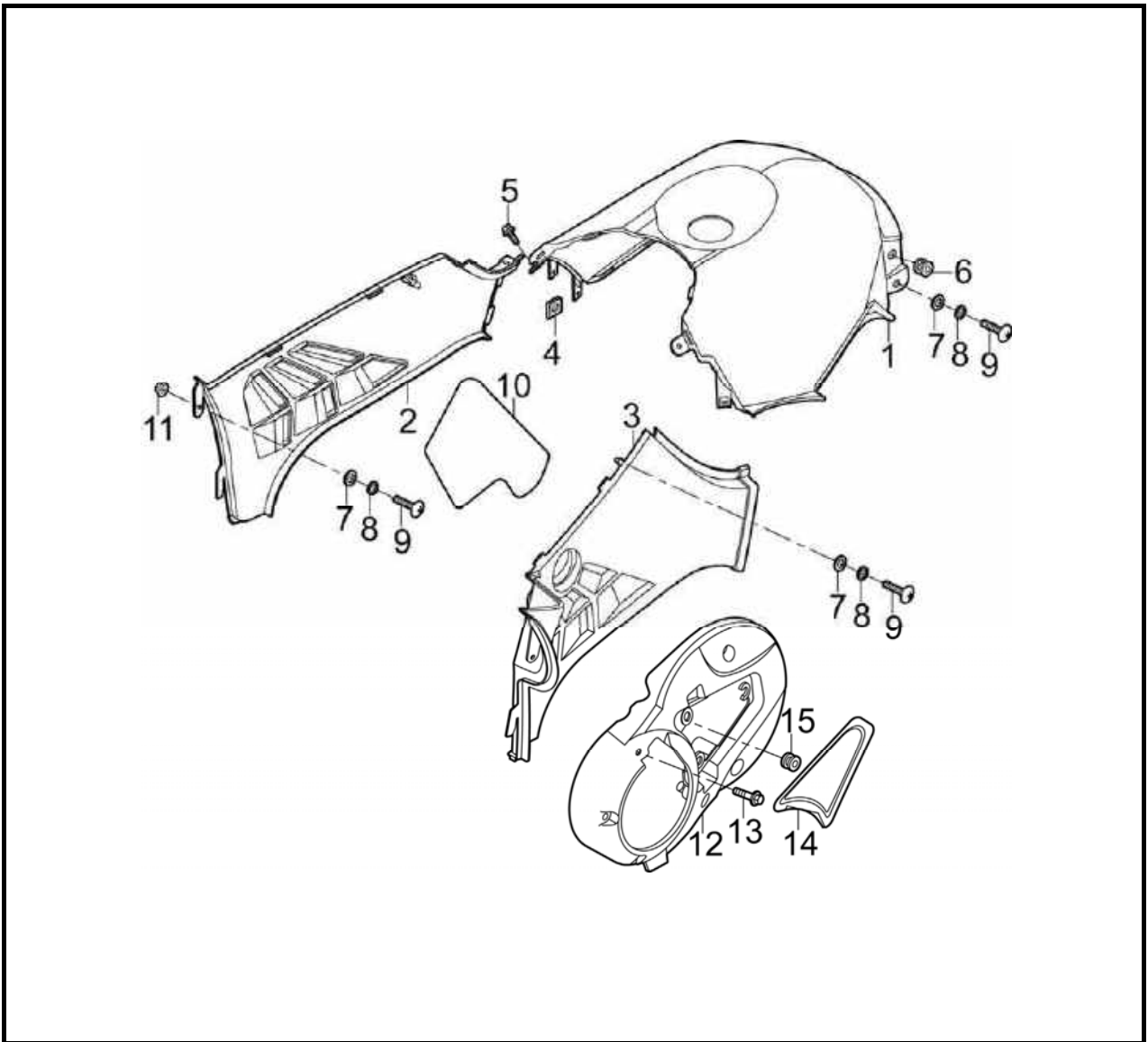

No.	Part Name	Qty	Remarks
11	Hexagon flange self-lock nuts M6	6	
12	Left strip, front cover	1	
13	Hexagon flange bolt M6×20	6	
14	Dipstick cover	1	
15	H style rubber ring $\Phi 9 \times \Phi 19-10$	3	

CHASSIS

FUEL TANK PARTS

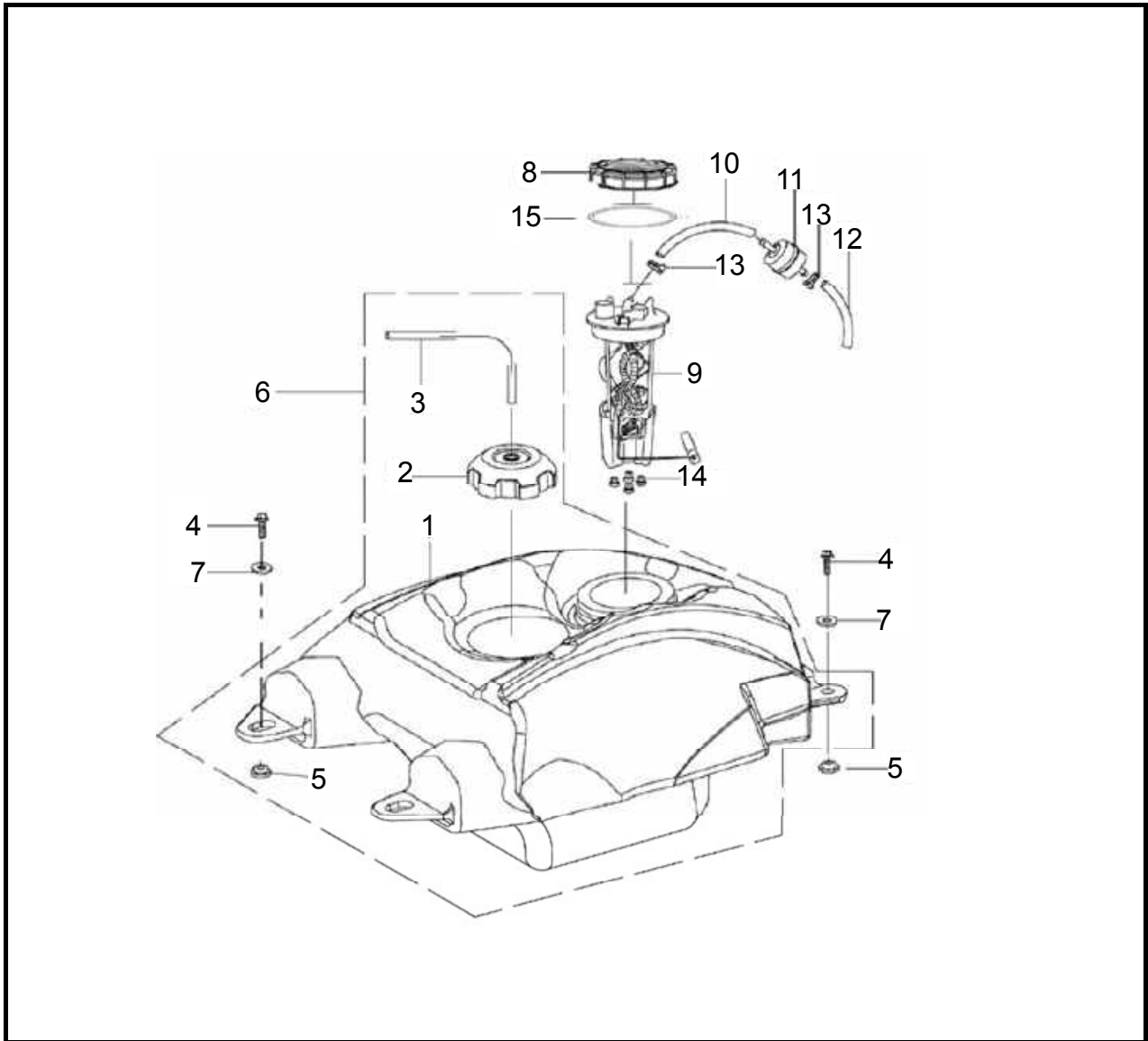

No.	Part Name	Qty	Remarks
	Removing the fuel tank		
1	Fuel tank	1	
2	Lid for fuel tank	1	
3	Fuel tank vent pipe $\Phi 5 \times \Phi 9 \times 400$	1	
4	Hexagon flange bolt M6×30	4	
5	Steps bushing $\Phi 6 \times \Phi 30 \times 13$	2	
6	Fuel tank assy	1	
7	Washer $\Phi 6 \times \Phi 25 \times 2$	2	
8	Cover, fuel pump	1	
9	Fuel pump	1	
10	Fuel pipe IV $\Phi 8 \times \Phi 14 \times 330$	1	
11	High voltage fuel filter	1	

CHASSIS

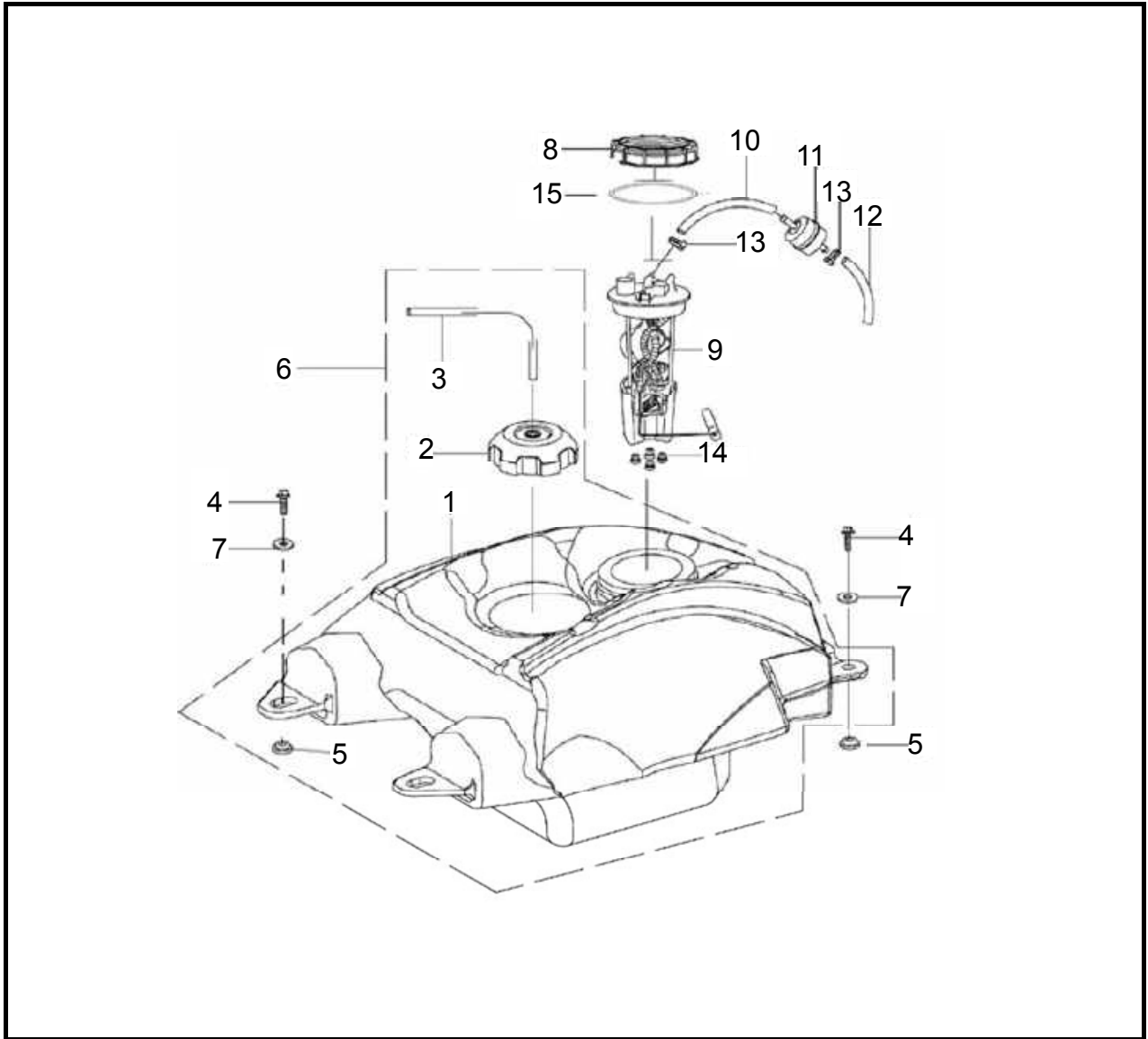

No.	Part Name	Qty	Remarks
12	Fuel pipe V $\Phi 8 \times \Phi 14 \times 130$	1	
13	Clamp	3	
14	Shock absorption rubber $\Phi 15-6$	4	
15	Seal gasket for fuel pump	1	

CHASSIS

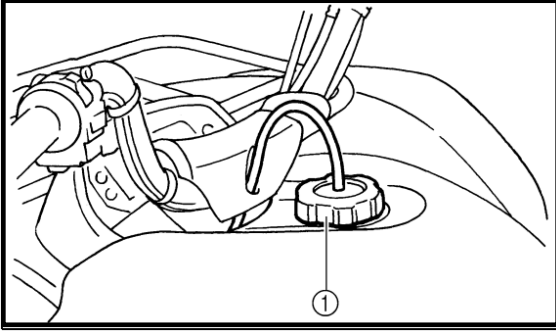

- Fuel tank cap

Remove the fuel tank cap by turning it counterclockwise.

ELECTRICAL COMPONENTS

ELECTRICAL SYSTEM MALFUNCTION INSPECTION

S/N	Phenomenon	Measure
1	Abnormal lights	1、 Check whether switches normal.
		2、 Check whether cables damaged.
		3、 Check whether lights damaged.
2	Fail to shift into four-wheel-drive or lock differential.	1、 Check whether four wheel drive switch normal.
		2、 Check whether power divider damaged.
		3、 Check whether differential mechanical conversion agency locked or damaged.
3	Fail to electric start	1、 Check whether battery undercharge.
		2、 Check whether starting motor damaged.
		3、 Check whether EFI damaged.
		4、 Check whether ignition coil normal.
		5、 Check whether spark plug fouling or ablative.
		6、 Check whether magneto ignition signal normal.
		7、 Check whether ECU plugged or damaged.
		8、 Check whether air filter plugged.
		9、 Check whether oil circuit smooth.
4	Abnormal speed indication between meter and mileage.	1、 Check whether sensor damaged.
		2、 Check whether meter damaged.
		3、 Check whether sensor surface polluted by iron scrap,
5	Neutral indicator of meter is not bright	1、 Check whether neutral switch damaged.
		2、 Check whether meter damaged.
		3、 Check whether cable damaged.
6	Reverse indicator of meter is not bright	1、 Check whether reverse switch damaged.
		2、 Check whether meter damaged.
		3、 Check whether cable damaged.
7	Other indicators of meter are not bright	1、 Check whether meter damaged.
		2、 Check whether cable damaged.
		3、 Check whether sensor or switch damaged

ELECTRICAL COMPONENTS

ELECTRICAL

ELECTRICAL COMPONENTS

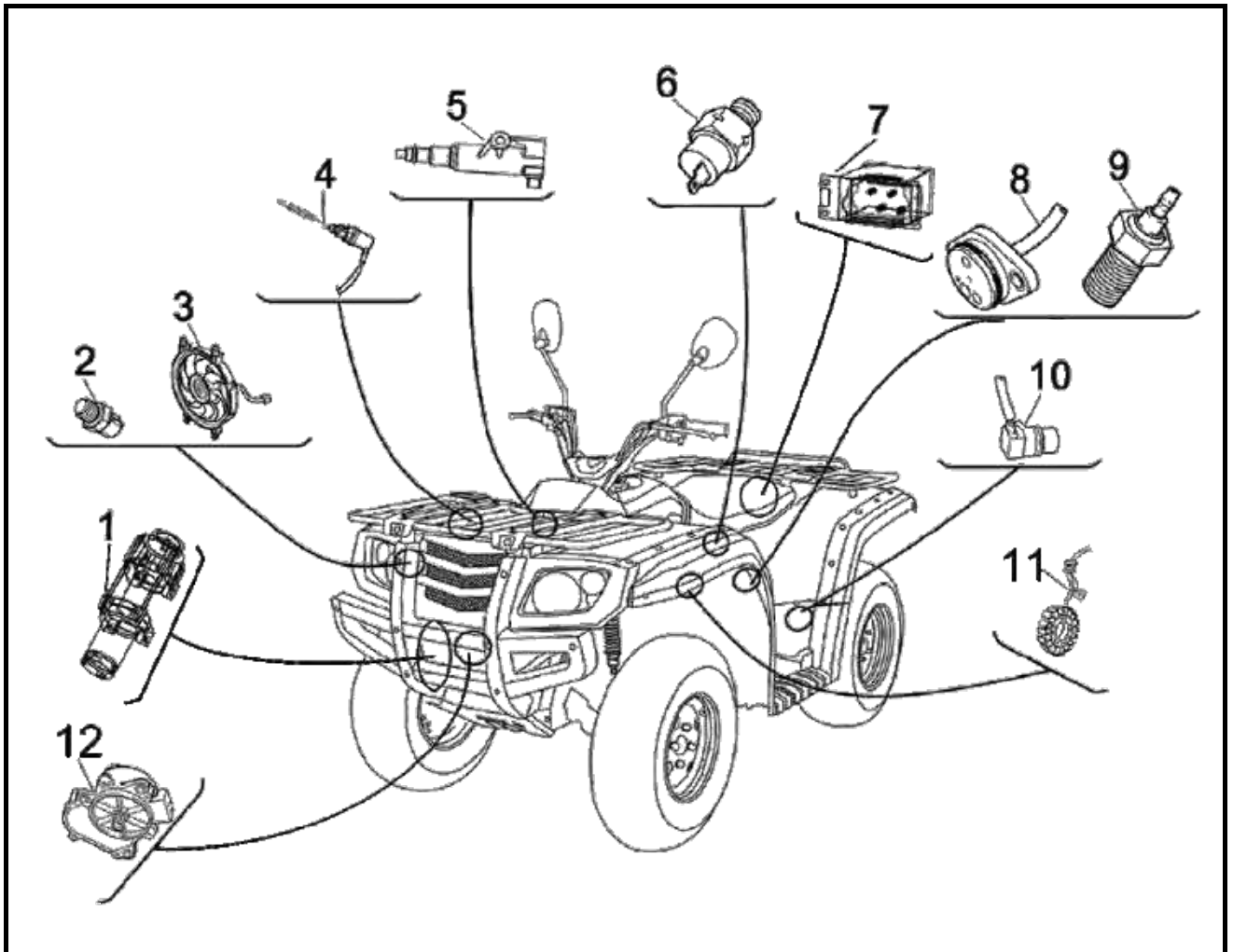

- | |
|---------------------------------|
| 1. Windlass |
| 2. Thermo switch 2 |
| 3. Radiator fan |
| 4. Brake light switch |
| 5. Ignition coil |
| 6. Thermo switch 1 |
| 7. Windlass controller |
| 8. Gear position switch |
| 9. Reverse switch |
| 10. Speed sensor |
| 11. Pickup coil/stator assembly |
| 12. Gear motor |

ELECTRICAL COMPONENTS

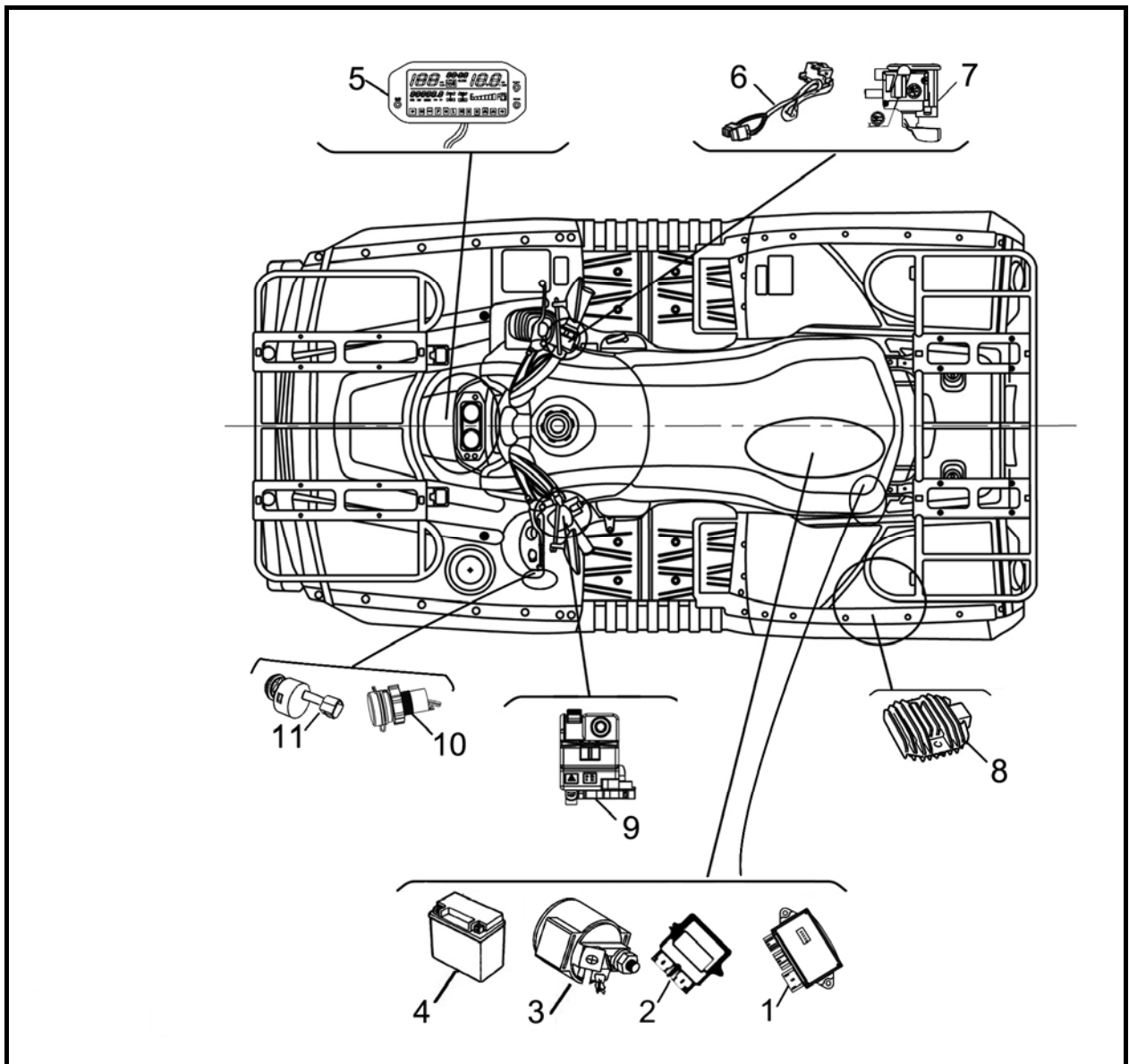

- | |
|---|
| 1. Relay assy. |
| 2. ECU. unit |
| 3. Starter relay |
| 4. Battery |
| 5. Speedmeter |
| 6. On-Command four-wheel drive switch and differential gear lock switch |
| 7. Right switch assy. |
| 8. Rectifier/regulator |
| 9. Left switch assy. |
| 10. DC socket |
| 11. Main switch |

ELECTRICAL COMPONENTS

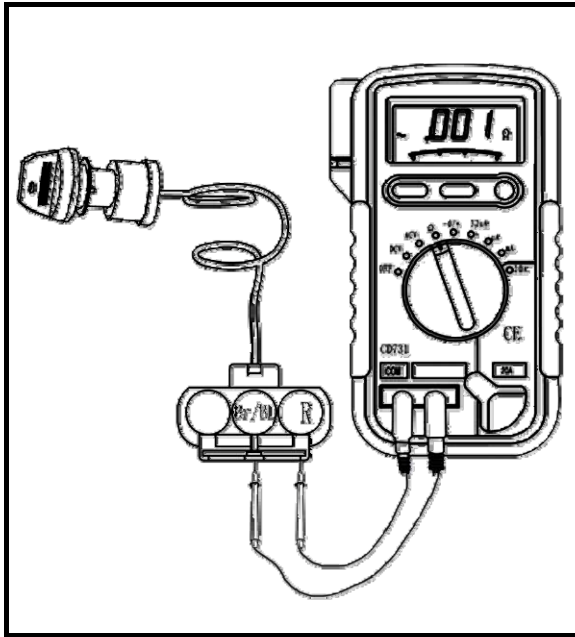

CHECKING THE SWITCH

Use a multimeter to check the terminals for continuity. If the continuity is faulty at any point, replace the switch.

NOTE:

- Set the multimeter to “0” before starting the test.
- The multimeter should be set to the “ $\Omega \times 1$ ” range when testing the switch for continuity.
- Turn the switch on and off a few times when checking it.

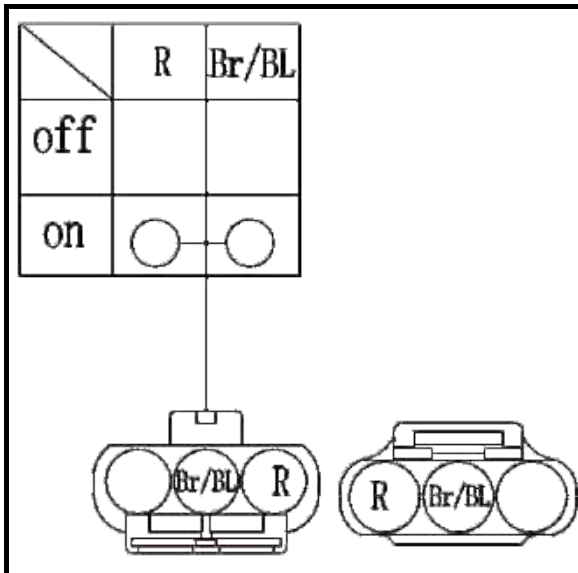

The terminal connections for switches (main switch, light switch, etc.) are shown in a chart similar to the one on the left. This chart shows the switch positions in the column and the switch lead colors in the top row.

For each switch position, “○—○” indicates the terminals with continuity.

The example chart shows that:

- ① There is continuity between the “Brown/Blue and Red” leads when the switch is set to “ON”.

ELECTRICAL COMPONENTS

Checking the switch continuity

Refer to "CHECKING THE SWITCH" and check for continuity between lead terminals. Poor connection, no continuity → Correct or replace.

* The coupler locations are circled.

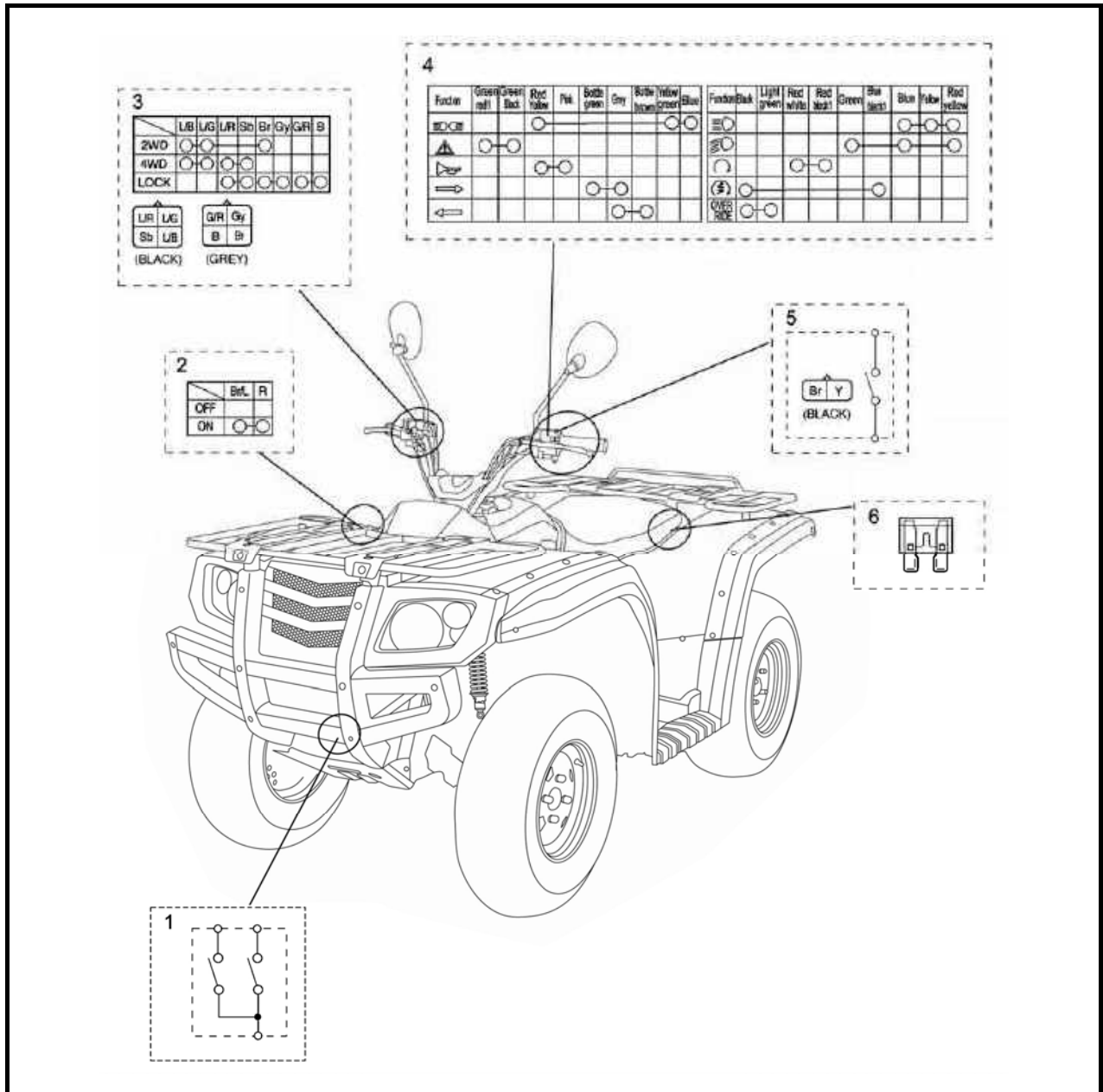

- | |
|---|
| 1. Four-wheel drive switch |
| 2. Main switch |
| 3. On-Command four-wheel drive switch and differential gear lock switch |
| 4. Light switch |
| 5. Brake light switch |
| 6. Fuse |

ELECTRICAL COMPONENTS

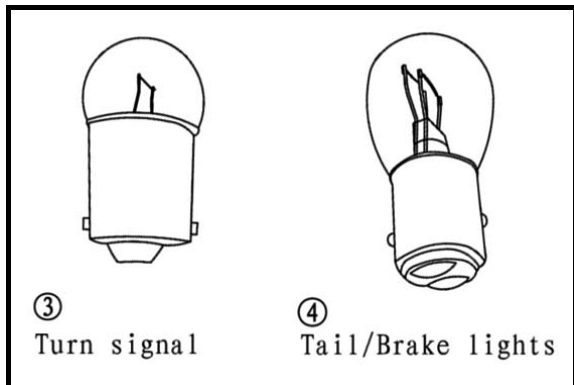
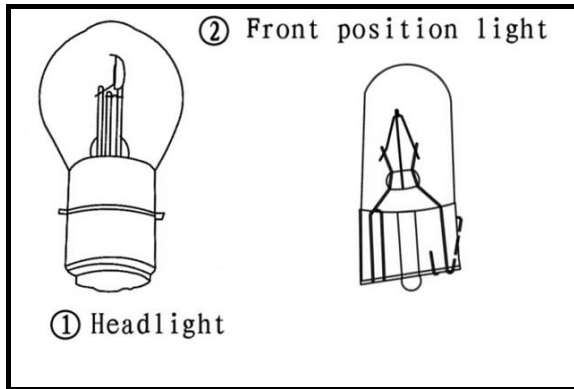

CHECKING THE BULBS AND BULB SOCKETS

Check each bulb and bulb socket for damage or wear, proper connections, and also for continuity between the terminals

Damage/wear → Repair or replace the bulb, bulb socket or both.

Improperly connected → Properly connect.

Incorrect continuity reading → Repair or replace the bulb, bulb socket or both.

WARNING:

Since the bulb gets extremely hot, keep flammable products and your hands away from the bulb until it has cooled down.

CAUTION:

- Be sure to hold the socket firmly when removing the bulb. Never pull the lead, otherwise it may be pulled out of the terminal in the coupler.
- Avoid touching the glass part of the bulb to keep it free from oil, otherwise the transparency of the glass, the life of the bulb and the luminous flux will be adversely affected. If the bulb gets soiled, thoroughly clean it with a cloth moistened with alcohol or lacquer thinner.

IGNITION SYSTEM

CIRCUIT DIAGRAM (see 347 page)

ELECTRICAL COMPONENTS

TROUBLESHOOTING

IF THE IGNITION SYSTEM FAILS TO OPERATE (NO SPARK OR INTERMITTENT SPARK):

Procedure

Check:

1. Fuses (main, ignition)
2. Battery
3. Spark plug
4. Ignition spark gap
5. Spark plug cap resistance
6. Ignition coil resistance
7. Main switch
8. Pickup coil resistance
9. Rotor rotation direction detection coil resistance
10. Wiring connection (the entire ignition system)

NOTE:

1. Cushion
2. Front frame
3. Front fender

Check and repair with following special tools.

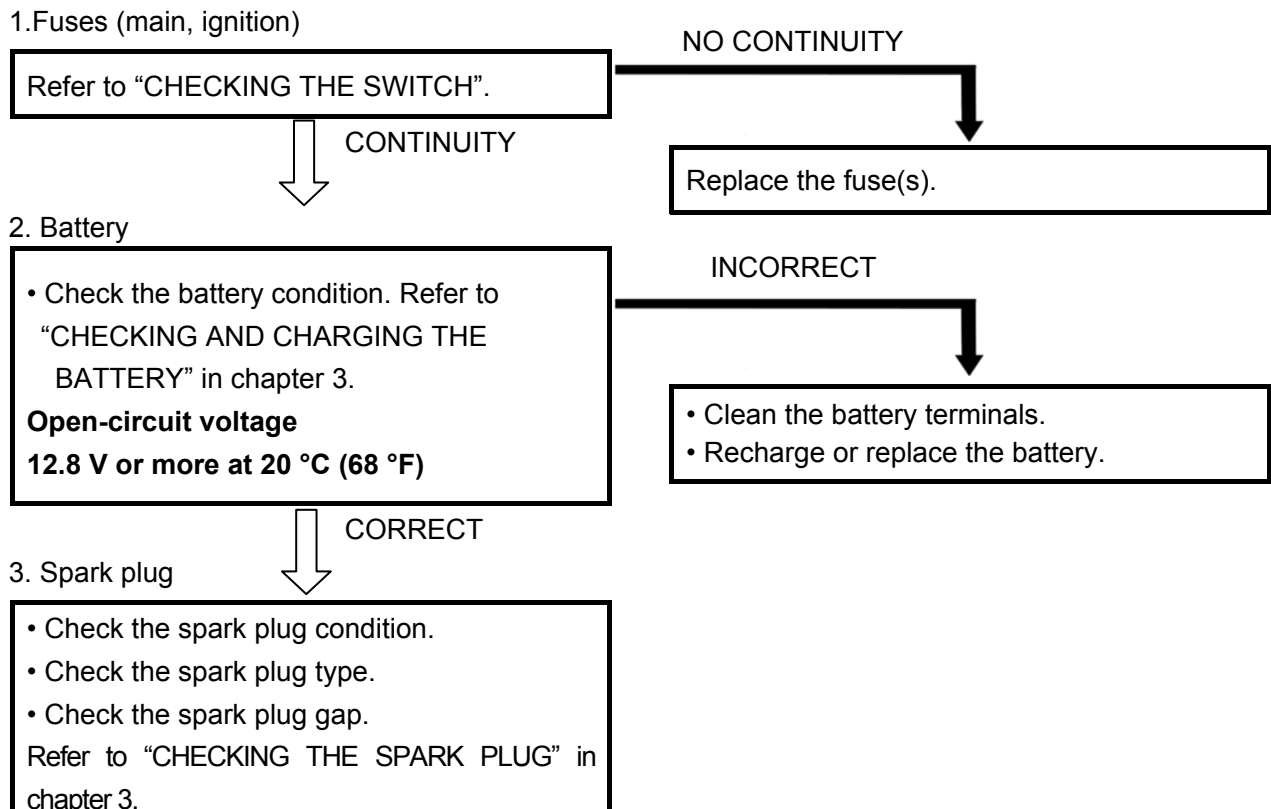

ELECTRICAL COMPONENTS

4. Ignition spark gap

- Disconnect the spark plug cap from the spark plug.
- Connect the pulse ignition spark checker or ignition checker ① as shown.

② Spark plug cap

- Turn the main switch to "ON".
- Check the ignition spark gap ②.
- Crank the engine by pushing the starter switch, and increase the spark gap until a misfiring occurs.

Minimum spark gap
6.0 mm (0.24 in)

OUT OF SPECIFICATION OR
NO SPARK

INCORRECT

Repair or replace the spark plug.

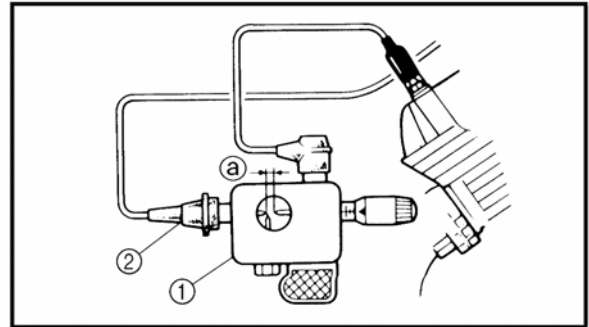

MEETS SPECIFICATION

The ignition system is not faulty.

5. Spark plug cap resistance

- Remove the spark plug cap.
- Connect the multimeter ($\Omega \times 1k$) to the spark plug cap.
- Check that the spark plug cap has the specified resistance.

Spark plug cap resistance
10 k Ω at 20 °C (68 °F)

MEETS SPECIFICATION

OUT OF SPECIFICATION

Replace the spark plug cap.

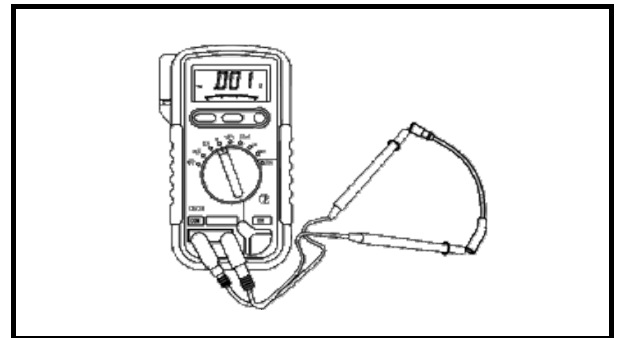

6. Ignition coil resistance

- Disconnect the ignition coil connector from the wire harness
- Connect the multimeter ($\Omega \times 1$) to the ignition coil.

Tester (+) lead → Orange lead terminal

Tester (-) lead → Ignition coil base

- Check that the primary coil has the specified

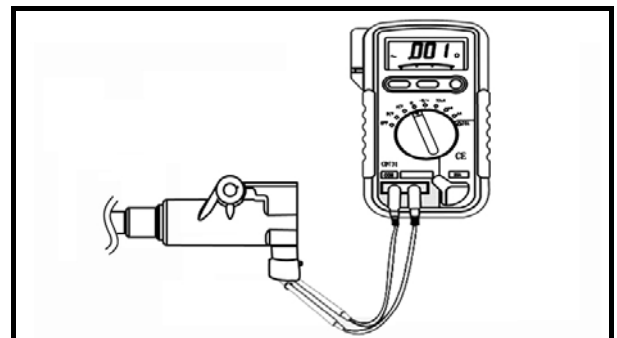

ELECTRICAL COMPONENTS

resistance.

Primary coil resistance

0.18 ~ 0.28 Ω at 20 °C (68 °F)

- Connect the multimeter($\Omega \times 1k$) to the ignition coil.

Tester (+) lead → Orange lead terminal

Tester (-) lead → Spark plug lead

- Check that the secondary coil has the specified resistance.

Secondary coil resistance

6.32 ~ 9.48 k Ω at 20 °C (68 °F)

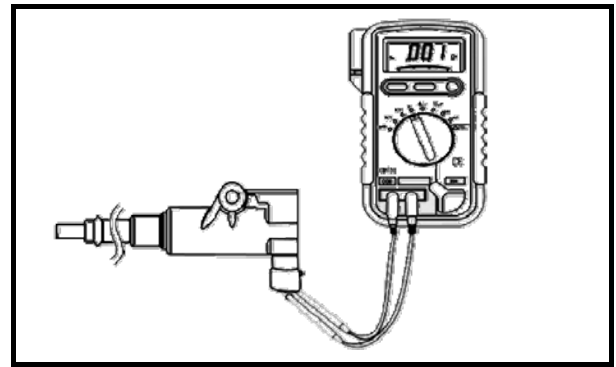
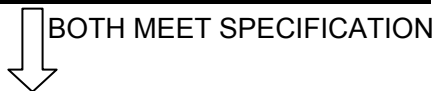

OUT OF SPECIFICATION

Replace the ignition coil.

INCORRECT

Replace the main switch.

7. Main switch

Refer to "CHECKING THE SWITCH"

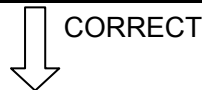

8. Pickup coil resistance

- Disconnect the A.C. magneto coupler from the wire harness.
- Connect the multimeter($\Omega \times 100$) to the pickup coil terminal.

Tester (+) lead → White/Red terminal ①

Tester (-) lead → White/Green terminal ②

- Check the pickup coil for the specified resistance.

Pickup coil resistance

459 ~ 561 Ω at 20 °C (68 °F)

(White/Red – White/Green)

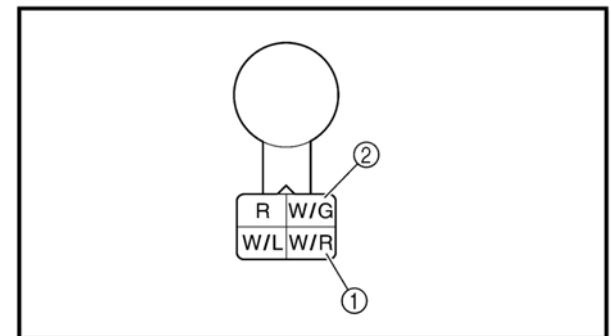
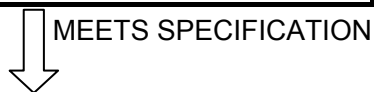

OUT OF SPECIFICATION

Replace the pickup coil/stator assembly.

9. Rotor rotation direction detection coil resistance

- Disconnect the A.C. magneto coupler from the wire harness.
- Connect the multimeter($\Omega \times 1$) to the rotor rotation direction detection coil terminal.

Tester (+) lead → Red terminal ①

Tester (-) lead → White/Blue terminal ②

- Check the rotor rotation direction detection coil for the specified resistance.

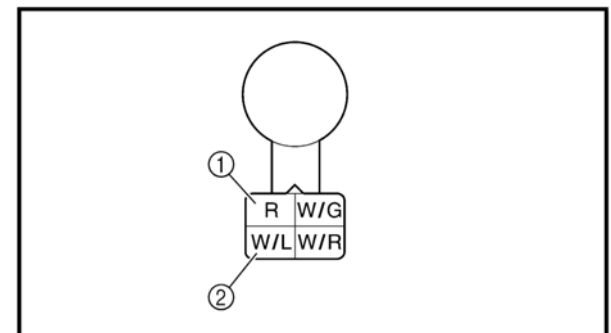

ELECTRICAL COMPONENTS

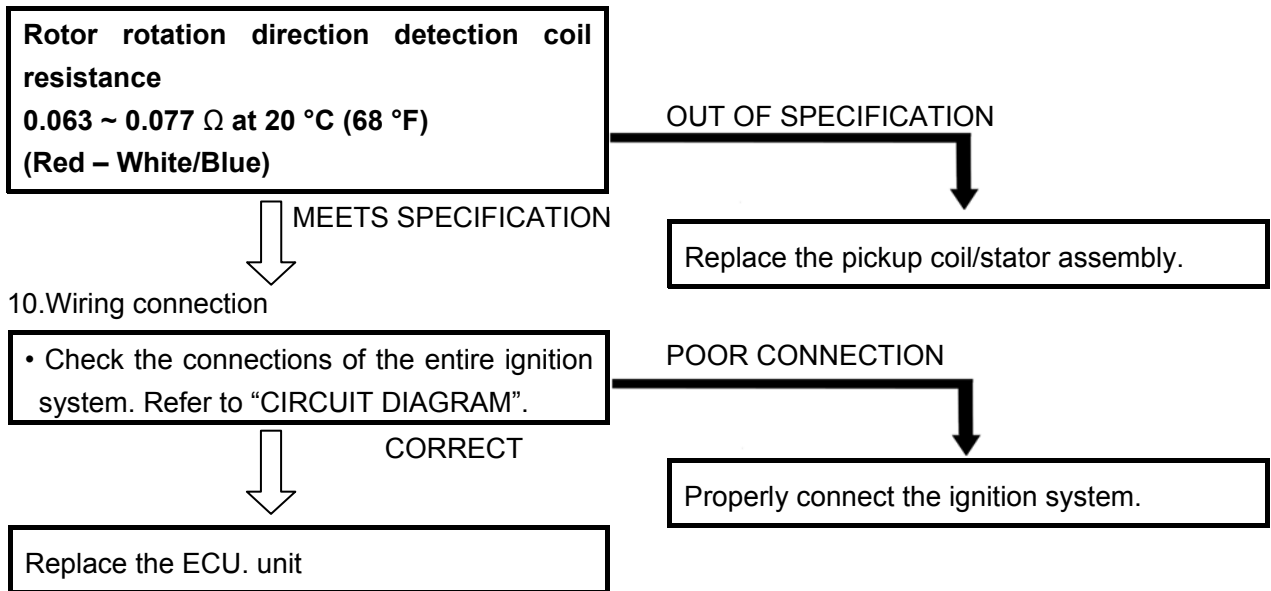

ELECTRIC STARTING SYSTEM
CIRCUIT DIAGRAM (see 349 page)

ELECTRICAL COMPONENTS

TROUBLESHOOTING

IF THE STARTER MOTOR FAILS TO OPERATE:

Procedure

Check:

1. Fuses (main, ignition, signaling system)
2. Battery
3. Starter motor
4. Starter relay
5. Main switch
6. Gear position switch
7. Brake light switch
8. Wiring connection (the entire starting system)

NOTE:

- Remove the following part(s) before troubleshooting:
 1. Console
 2. Front frame
 3. Front fender
- Use the following special tool(s) for troubleshooting.

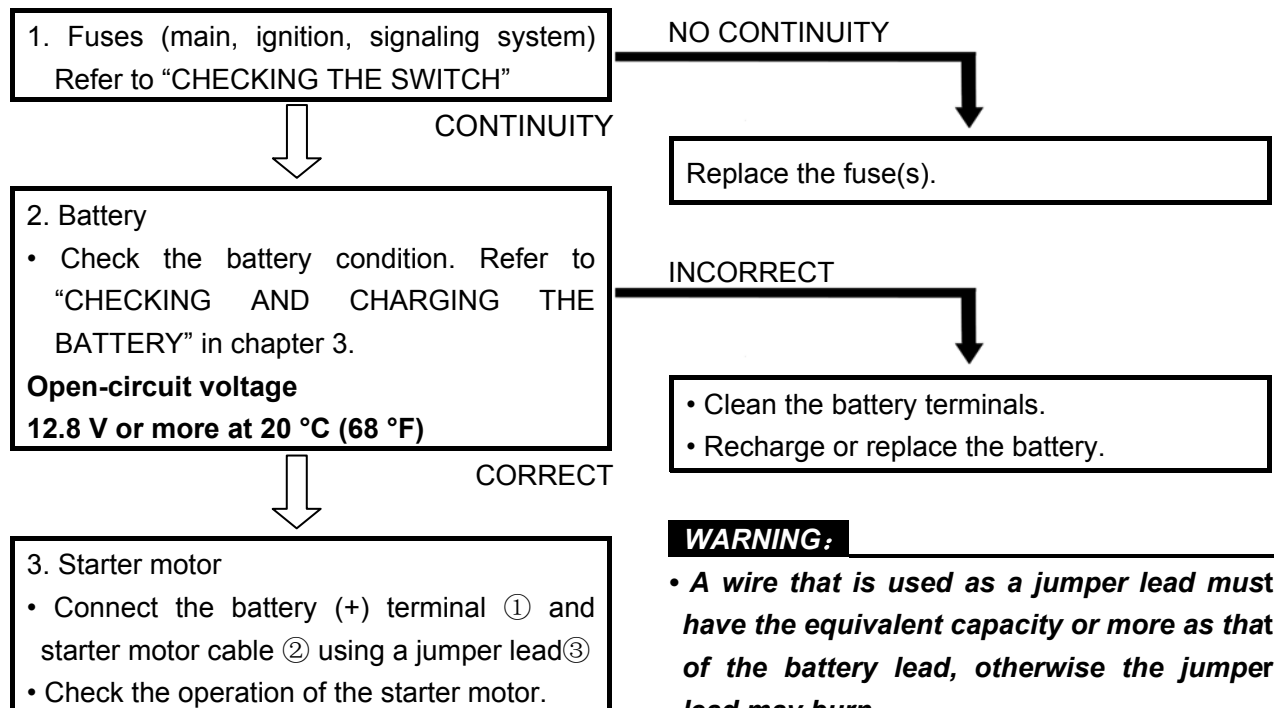

WARNING:

- A wire that is used as a jumper lead must have the equivalent capacity or more as that of the battery lead, otherwise the jumper lead may burn.
- This check is likely to produce sparks, so be sure that no flammable gas or fluid is in the vicinity.

ELECTRICAL COMPONENTS

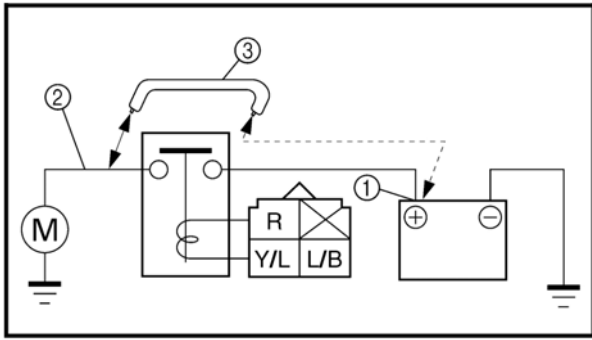

TURNS

4. Starter relay

- Remove the starter relay from the wire harness.
- Connect the multimeter ($\Omega \times 1$) and the battery (12 V) to the starter relay terminals.

Battery (+) terminal → Yellow/Blue terminal ①
Battery (-) terminal → Blue/Black terminal ②
Tester (+) lead → Red terminal ③
Tester (-) lead → Black terminal ④

- Check the starter relay for continuity.

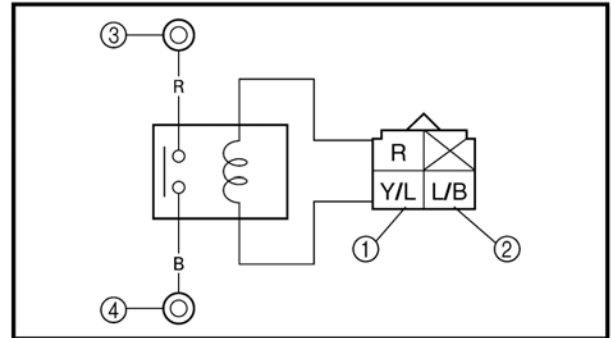

NO CONTINUITY

5. Main switch Refer to "CHECKING THE SWITCH".

CORRECT

INCORRECT

6. Gear position switch Refer to "CHECKING THE SWITCH".

CORRECT

INCORRECT

7. Brake light switch Refer to "CHECKING THE SWITCH".

CORRECT

INCORRECT

8. Wiring connection

- Check the connections of the entire starting system. Refer to "CIRCUIT DIAGRAM".

POOR CONNECTION

Properly connect the starting system.

ELECTRICAL COMPONENTS

STARTER MOTOR

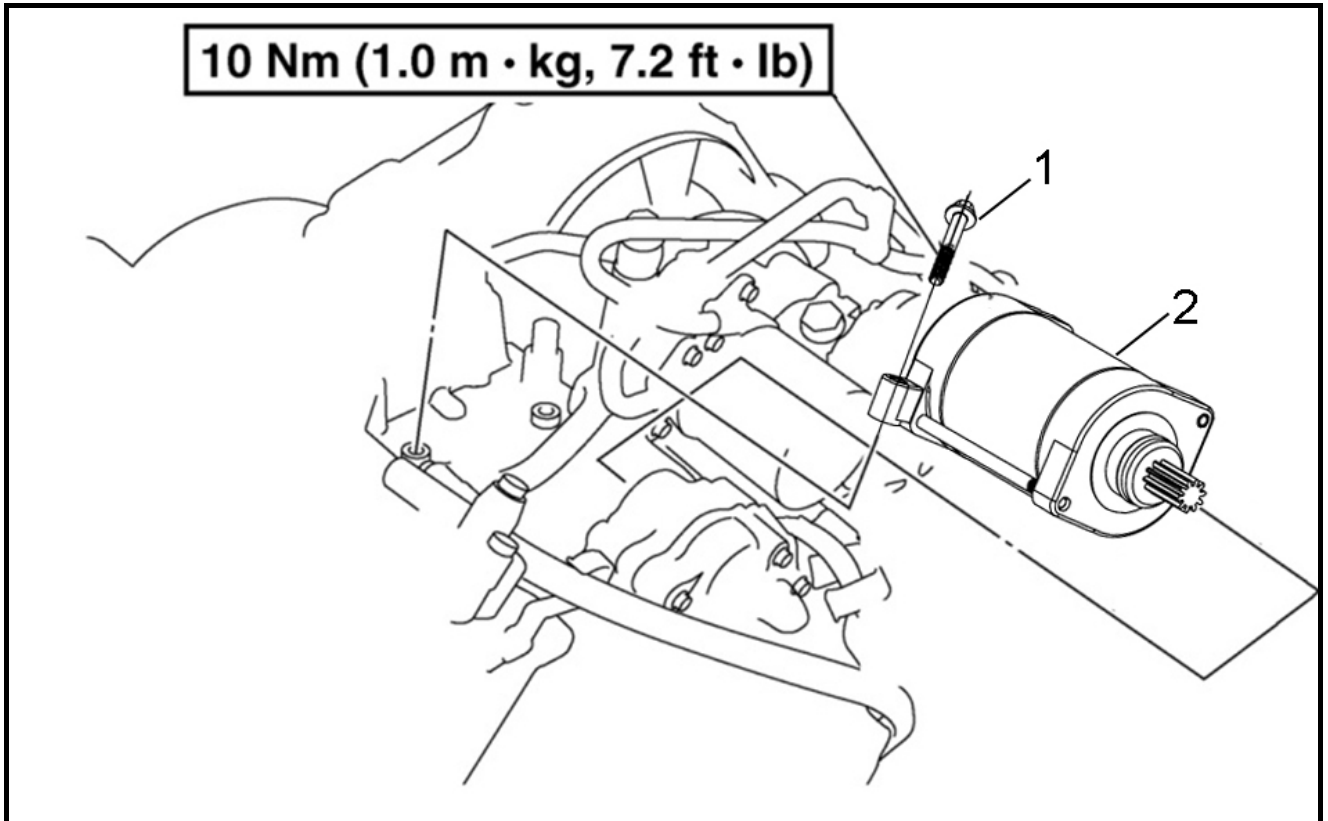

No.	Part Name	Qty	Remarks	The performance parameters
	Removing the starter motor	1	Remove the parts in the order listed	1、 no-load: 12V/300W 2、 Load: 12V/1400W 3、 The load torque:1.2N.m
1	Flange bolt			
2	Starter motor assy.			

CHARGING SYSTEM

CIRCUIT DIAGRAM (see 348 page)

ELECTRICAL COMPONENTS

TROUBLESHOOTING

IF THE BATTERY IS NOT CHARGED:

Procedure

Check:

1. Fuse (main)
2. Battery
3. Charging voltage

4. Charging coil resistance

5. Wiring connections(the entire charging system)

NOTE:

Remove some parts before maintenance

1. Cushion

Repair with following special toolings

1. Fuse (main)

Refer to "CHECKING THE SWITCH".

CONTINUITY

NO CONTINUITY

Replace the fuse.

2. Battery

- Check the battery condition. Refer to "CHECKING AND CHARGING THE BATTERY" in chapter 3.

Open-circuit voltage

12.8 V or more at 20 °C (68 °F)

CORRECT

INCORRECT

- Clean the battery terminals.
- Recharge or replace the battery.

3. Charging voltage

- Connect the engine tachometer to the spark plug lead.
- Connect the multimeter(DC 20 V) to the battery.

Tester (+) lead → Battery (+) terminal

Tester (-) lead → Battery (-) terminal

- Start the engine and accelerate to about 1,000 r/min.

Charging voltage 14 V at 1,000 r/min

NOTE:

Use a fully charged battery.

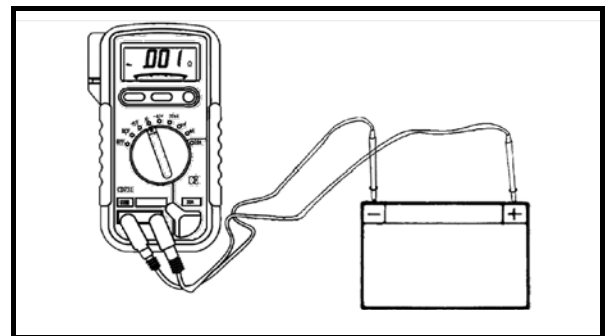

MEETS SPECIFICATION

OUT OF SPECIFICATION

The charging circuit is not faulty.

ELECTRICAL COMPONENTS

4. Charging coil resistance

- Disconnect the A.C. magneto coupler from the wire harness.
- Connect the multimeter ($\Omega \times 1$) to the charging coils.

Tester (+) lead → White terminal ①

Tester (-) lead → White terminal ②

Tester (+) lead → White terminal ①

Tester (-) lead → White terminal ③

- Measure the charging coil resistance.

Charging coil resistance

0.32 ~ 0.43 Ω at 20 °C (68 °F)

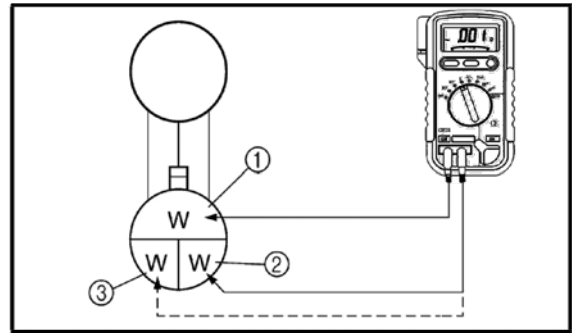

OUT OF SPECIFICATION

Replace the pickup coil/stator assembly.

MEETS SPECIFICATION

5. Wiring connections

- Check the connections of the entire charging system. Refer to "CIRCUIT DIAGRAM".

CORRECT

POOR CONNECTION

Properly connect the charging system.

Replace the rectifier/regulator.

LIGHTING SYSTEM

CIRCUIT DIAGRAM (see 350page)

ELECTRICAL COMPONENTS

TROUBLESHOOTING

IF THE HEADLIGHT AND/OR TAILLIGHT FAIL TO COME ON:

Procedure

Check

1. Fuses (main, lighting system)
2. Battery
3. Main switch

4. Light switch

5. Wiring connections(the entire lighting system)

NOTE:

• Remove the following part(s) before troubleshooting:

1. Console
2. Front luggage carrir
3. Front covering parts

• Use special tool(s) for troubleshooting.

1. Fuses (main, lighting system)

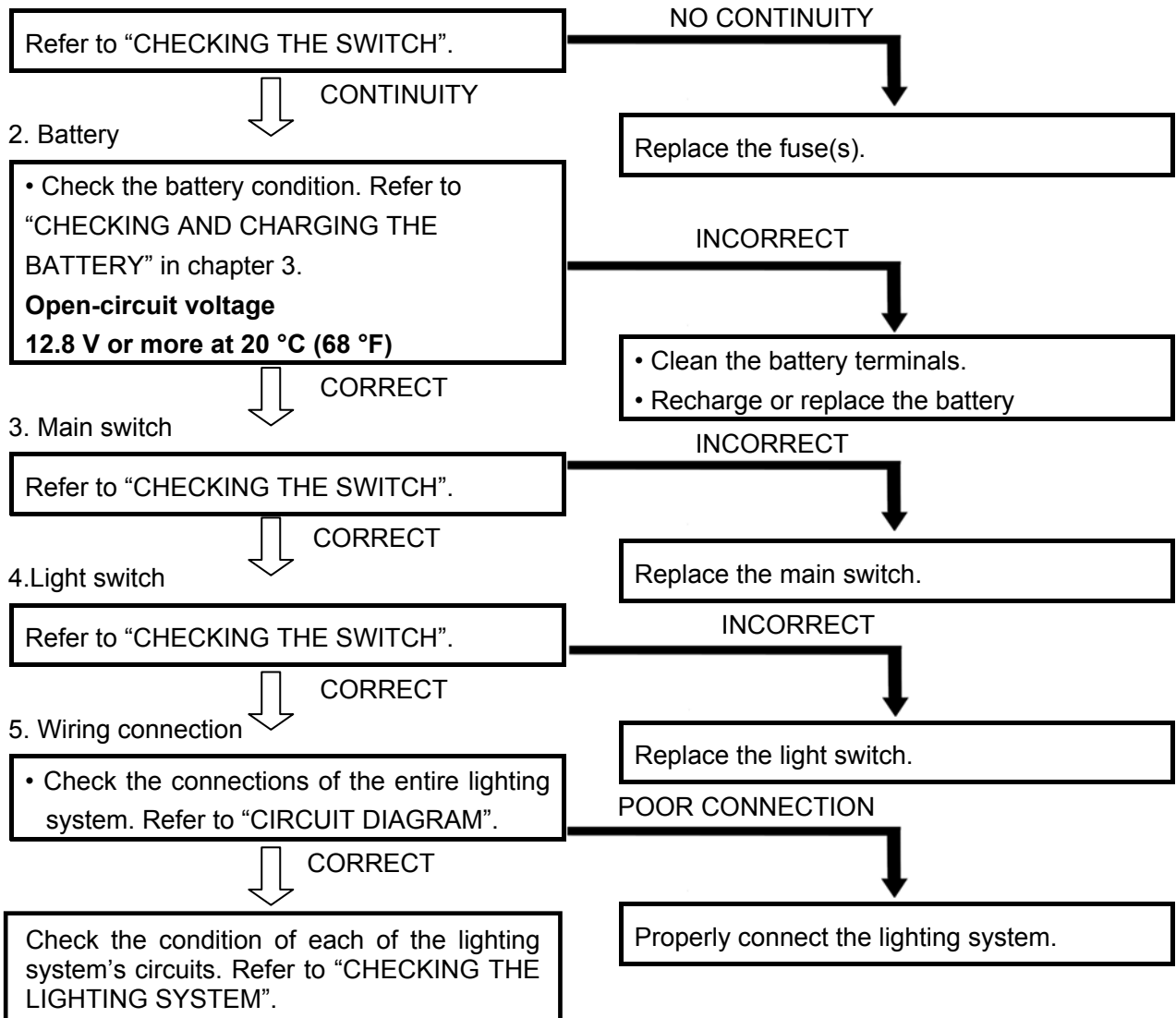

ELECTRICAL COMPONENTS

CHECKING THE LIGHTING SYSTEM

1. If the headlights fail to come on:

(1). Bulb and bulb socket

- Check the bulb and bulb socket for continuity.



CONTINUITY

(2). Voltage

- Connect the multimeter(DC 20 V) to the headlight couplers.



Tester (+) lead →

Green terminal ① or Yellow terminal ②

Tester (-) lead → Black terminal ③

Ⓐ When the light switch is on “”.

Ⓑ When the light switch is on “”

- Turn the main switch to “ON”.
- Turn the light switch to “” or “”.
- Check the voltage (12 V) of the “Green” and “Yellow” leads on the bulb socket connector.



MEETS SPECIFICATION

This circuit is not faulty.

NO CONTINUITY

Replace the bulb and/or bulb socket.

A

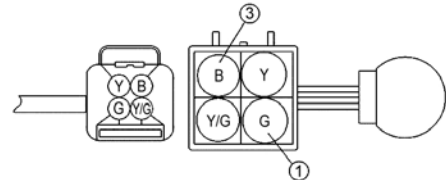

B

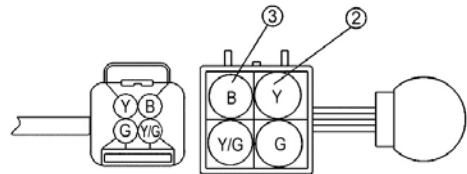

OUT OF SPECIFICATION

The wiring circuit from the main switch to the bulb socket connector is faulty, repair it.

ELECTRICAL COMPONENTS

2. If the taillights fail to come on:

(1). Bulb and bulb socket

- Check the bulb and bulb socket for continuity.

CONTINUITY

NO CONTINUITY

Replace the bulb and/or bulb socket.

(2) . Voltage

- Connect the multimeter(DC 20 V) to the tail/brake light couplers.
Tester (+) lead → Blue lead terminal ①
Tester (-) lead → Black lead terminal ②
- Turn the main switch to "ON".
- Turn the light switch to "←" or "→".
- Check the voltage (12 V) of the "Blue" lead on the bulb socket connector.

MEETS SPECIFICATION

This circuit is not faulty.

OUT OF SPECIFICATION

The wiring circuit from the main switch to the bulb socket connector is faulty, repair it.

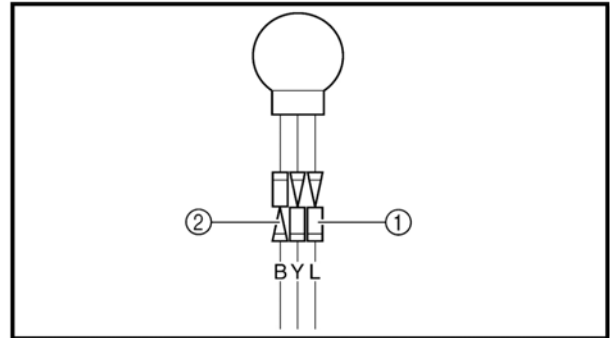

SIGNALING SYSTEM

CIRCUIT DIAGRAM (see 351page)

ELECTRICAL COMPONENTS

TROUBLESHOOTING

IF A BRAKE LIGHT, AN INDICATOR LIGHT, OR THE WARNING LIGHT FAILS TO COME ON:

Procedure

Check:

1. Fuses (main, signaling system)
2. Battery

3. Main switch
4. Wiring connections (the entire signal system)

NOTE:

- Remove the following part(s) before troubleshooting:
 1. Console
 2. Front frame
 3. Front pedal
- Use special tool(s) for troubleshooting.

1. Fuses (main, signaling system)

Refer to "CHECKING THE SWITCH".

CONTINUITY

NO CONTINUITY

Replace the fuse(s).

2. Battery

• Check the battery condition. Refer to "CHECKING AND CHARGING THE BATTERY" in chapter 3.

Open-circuit voltage

12.8 V or more at 20 °C (68 °F)

CORRECT

INCORRECT

- Clean the battery terminals.
- Recharge or replace the battery.

3. Main switch

Refer to "CHECKING THE SWITCH".

CORRECT

INCORRECT

Replace the main switch

4. Wiring connections

• Check the connections of the entire signal system. Refer to "CIRCUIT DIAGRAM".

CORRECT

POOR CONNECTION

Properly connect the signal system.

Check the condition of each of the signal system's circuits. Refer to "CHECKING THE SIGNAL SYSTEM".

ELECTRICAL COMPONENTS

CHECKING THE SIGNAL SYSTEM

1. If the brake lights fail to come on:

(1). Bulb and bulb socket

- Check the bulb and bulb socket for continuity.

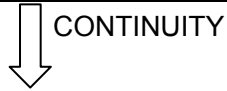

NO CONTINUITY

Replace the bulb and/or bulb socket.

(2). Brake light switch

Refer to "CHECKING THE SWITCH".

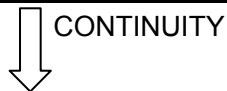

NO CONTINUITY

Replace the brake light switch.

(3). Voltage

- Connect the multimeter(DC 20 V) to the bulb socket connector.

Tester (+) lead → Yellow terminal ①

Tester (-) lead → Black terminal ②

- Turn the main switch to "ON".
- Turn the light switch to "⚡" or "⚡".

- Check the voltage (12 V) of the "Yellow" lead on the bulb socket connector.

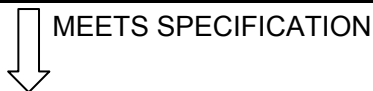

This circuit is not faulty.

OUT OF SPECIFICATION

The wiring circuit from the main switch to the bulb socket connector is faulty, repair it.

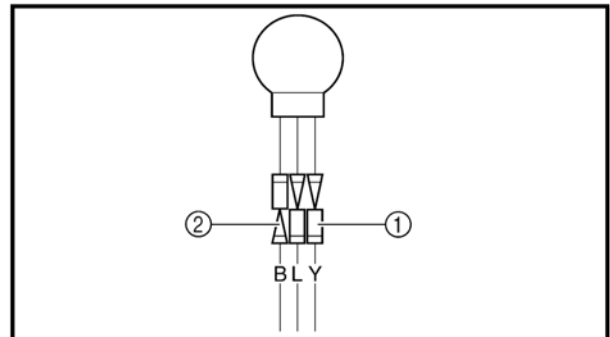

ELECTRICAL COMPONENTS

2. If L, H, N, R, light is not bright

(1). Gear position switch

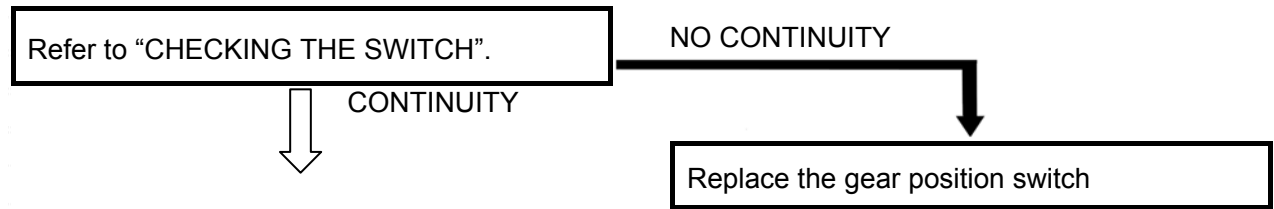

(2). Wire connection

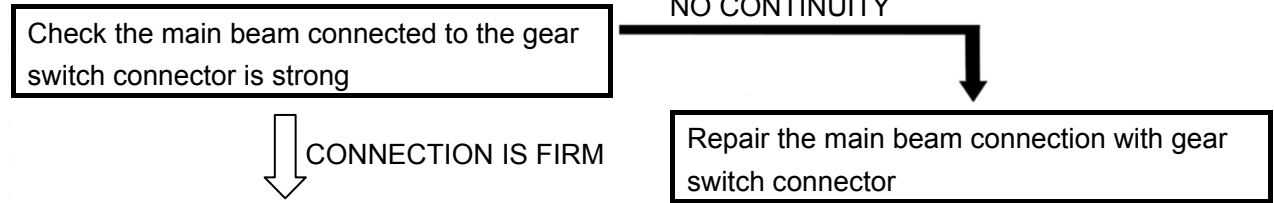

This circuit is not faulty.

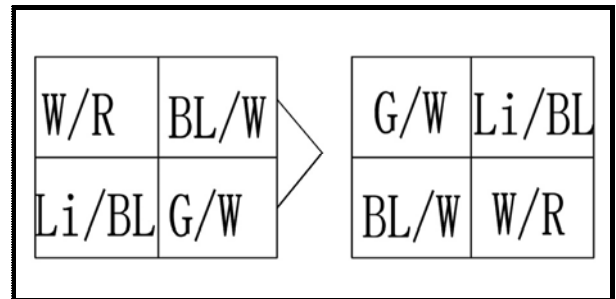

ELECTRICAL COMPONENTS

3. If the parking brake indicator light fails to come on:

(1). Brake switch

Refer to "CHECKING THE SWITCH".

CONTINUITY

NO CONTINUITY

Replace the parking brake switch

(2). Voltage

Set the multimeter to DC12V, test the brake lamp voltage at both ends

Red power meter pens → ①

Black power meter pens → ②

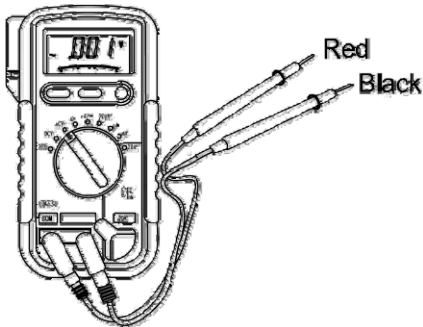

DISPLAY +12V

This circuit is not faulty.

NO VOLATGE DISPLAY

Replace the fuse F2

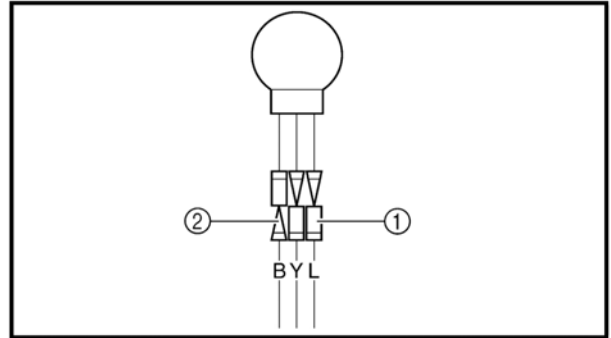

ELECTRICAL COMPONENTS

4. If the reverse indicator light fails to come on:

(1). Directional signal switch

Refer to "CHECKING THE SWITCH".



CONTINUITY

NO CONTINUITY



Replace the Reverse switch

(2). Voltage

Set the multimeter to DC12V, test the direction lamp voltage at both ends

Red power meter pens → ①

Black power meter pens → ②

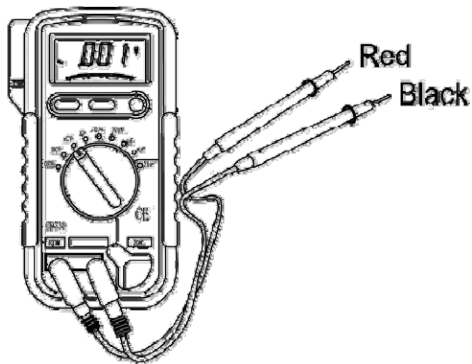

DISPLAY +12V

This circuit is not faulty.

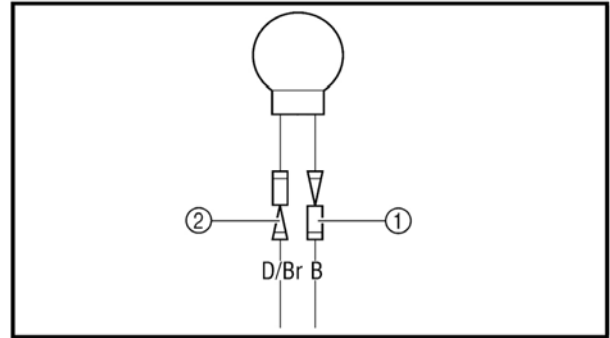

NO VOLATGE DISPLAY



Replace the fuse F2

ELECTRICAL COMPONENTS

5. If the coolant temperature warning light does not come on when the main switch to "ON", or if the coolant temperature warning light does not come on when the temperature is high (more than 117 ~ 123 °C (242.6 ~ 253.4 °F):

(1). Connection reliability

- Check whether the wire connected to the sensor is strong.

NO CONTINUITY

Repair connect an external plug-in

(2). Thermo switch 1

CONTINUITY

- Remove the thermo switch 1 from the cylinder head.
- Connect the multimeter($\Omega \times 1$) to the thermo switch 1 ①.
- Immerse the thermo switch 1 in coolant ②.
- Check the thermo switch 1 for continuity. While heating the coolant use a thermometer ③ to record the temperatures.

- Ⓐ The thermo switch 1 circuit is open and the coolant temperature warning light is off.
- Ⓑ The thermo switch 1 circuit is closed and the coolant temperature warning light is on.

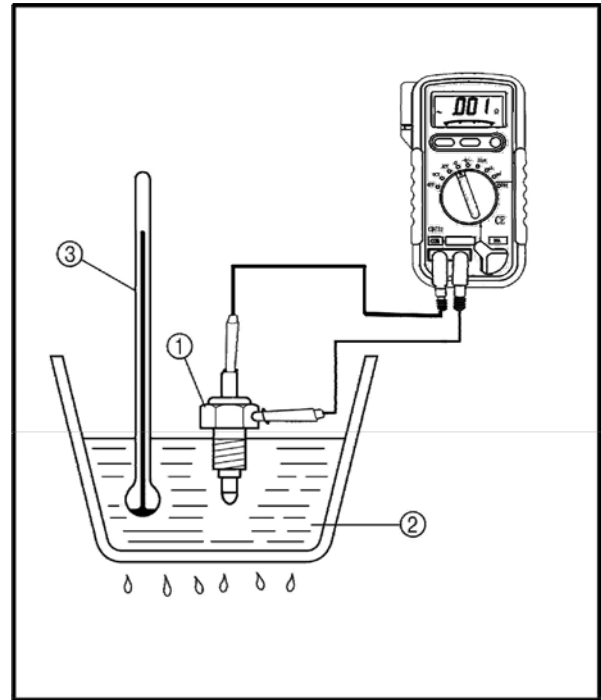

Test step	Coolant temperature	Continuity
1	Less than 120 ± 3 °C (248 ± 5.4 °F)	No
2	More than 120 ± 3 °C (248 ± 5.4 °F)	Yes
3	More than 113 °C (235.4 °F)	Yes
4	Less than 113 °C (235.4 °F)	No

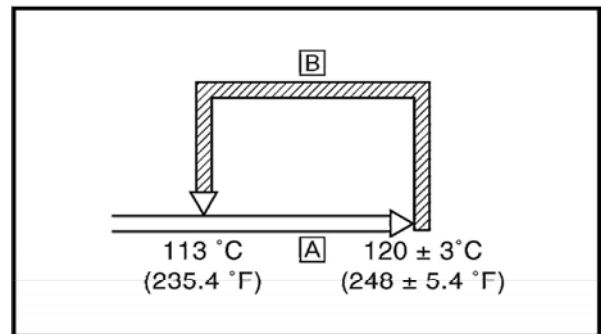

Test steps 1 & 2: Heating phase

Test steps 3 & 4: Cooling phase

WARNING:

Handle the thermo switch 1 with special care.

Never subject it to a strong shock or allow it to be dropped. Should it be dropped, it must be replaced.

BAD CONDITION

Replace the thermo switch 1

ELECTRICAL COMPONENTS

6. If the four-wheel drive and front bridge differential lock indicator light fails to come on:

(1). Check the driver combination switch and front axle differential switch

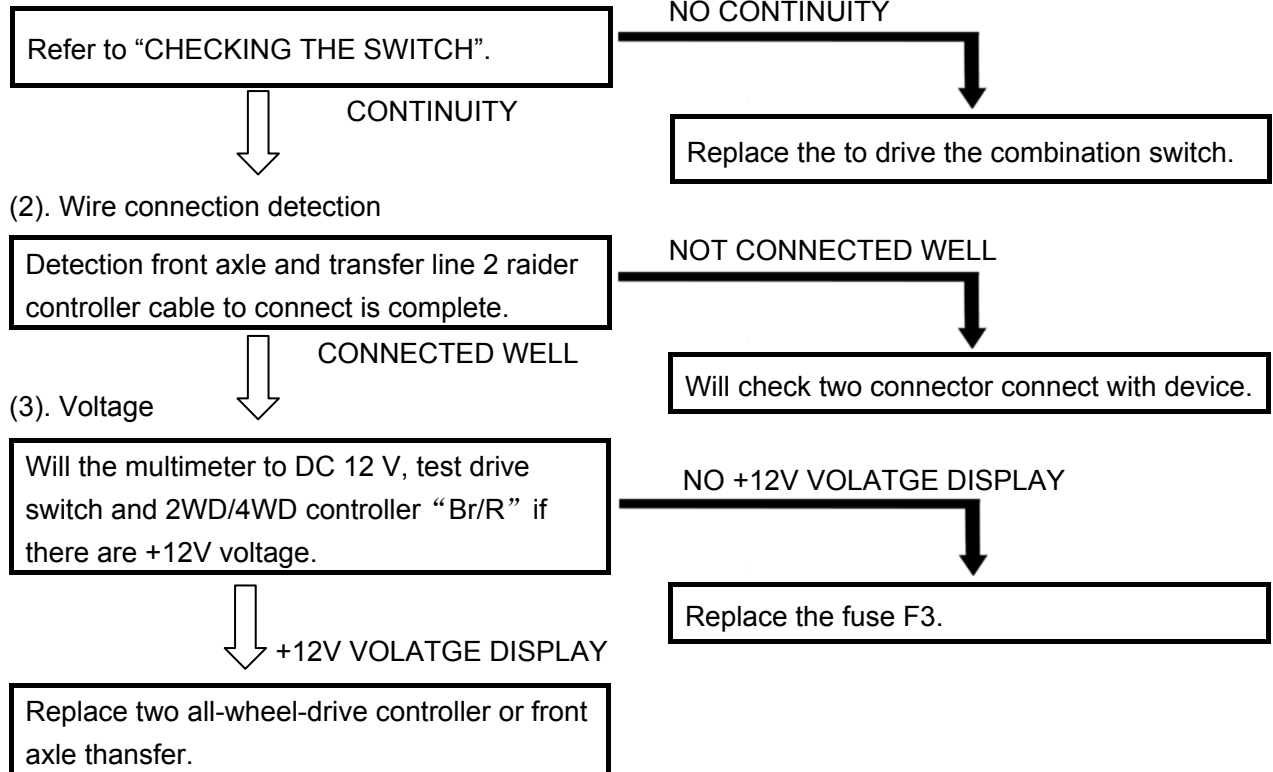

ELECTRICAL COMPONENTS

7. If the four-wheel drive indicator light fails to come on:

(1). Bulb and bulb socket

- Check the bulb and bulb socket for continuity.



CONTINUITY

NO CONTINUITY

Replace the bulb and/or bulb socket.

(2). four-wheel drive indicator light relay

- Remove the four-wheel drive indicator light relay from the wire harness.
- Connect the multimeter ($\Omega \times 1$) and the battery (12 V) to the four-wheel drive indicator light relay terminals.
- Check the four-wheel drive indicator light relay for continuity as follows.

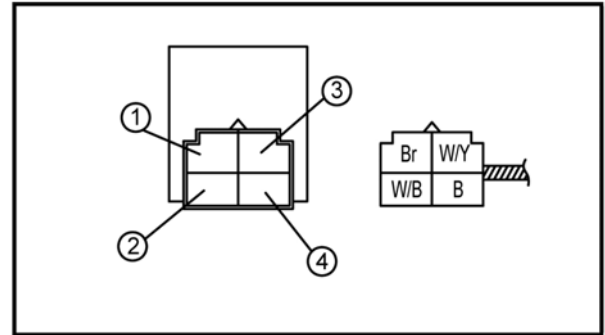

Tester (+) lead → White/Yellow terminal ① Tester (-) lead → Black terminal ②	Continuity
Battery (+) terminal → Brown terminal ③ Battery (-) terminal → White /Black terminal ④	
Tester (-) lead → White/Yellow terminal ① Tester (+) lead → Black terminal ②	No continuity



CONTINUITY

NO CONTINUITY

Replace the four-wheel drive indicator light relay.

(3). Four-wheel drive switch

Refer to "CHECKING THE SWITCH".



CONTINUITY

NO CONTINUITY

Replace the gear motor.

ELECTRICAL COMPONENTS

(4).Voltage

- Connect the multimeter(DC 20 V) to the indicator light assembly 1 coupler.

Tester (+) lead → Brown terminal ①

Tester (-) lead → White/Yellow terminal ②

- Turn the main switch to “ON”.
- Check the voltage (12 V)

MEETS SPECIFICATION
↓

This circuit is not faulty.

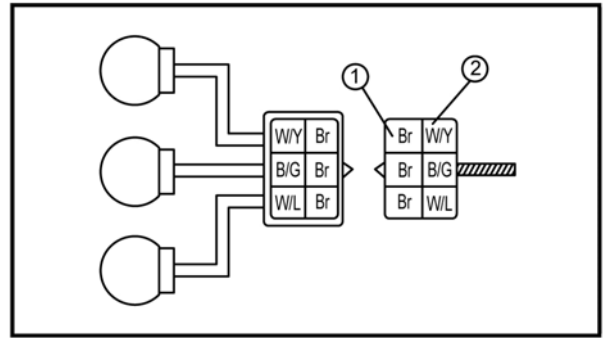

OUT OF SPECIFICATION
↓

The wiring circuit from the main switch to the bulb socket connector is faulty, repair it.

COOLING SYSTEM

CIRCUIT DIAGRAM (see 352 page)

ELECTRICAL COMPONENTS

TROUBLESHOOTING

IF THE FAN MOTOR DOES NOT MOVE:

Procedure

Check:

1. Fuse (main)
2. Battery
3. Main switch
4. Radiator fan motor
5. Thermo switch 3
6. Wiring connection(the entire cooling system)

NOTE:

- Remove the following part(s) before troubleshooting.
 1. Console
 2. Front frame
 3. Front pedal
- Use special tool(s) for troubleshooting.

1. Fuse (main)

Refer to "CHECKING THE SWITCH".

CONTINUITY

NO CONTINUITY

Replace the fuse.

2. Battery

• Check the battery condition. Refer to "CHECKING AND CHARGING THE BATTERY" in chapter 3.

Open-circuit voltage:
12.8 V or more at 20 °C (68 °F)

CORRECT

INCORRECT

- Clean the battery terminals.
- Recharge or replace the battery

3. Main switch

Refer to "CHECKING THE SWITCH".

CORRECT

INCORRECT

Replace the main switch.

ELECTRICAL COMPONENTS

4. Radiator fan motor

- Disconnect the radiator fan motor coupler.
- Connect the battery (12 V) as shown.

Battery (+) lead → Blue terminal ①

Battery (-) lead → Black terminal ②

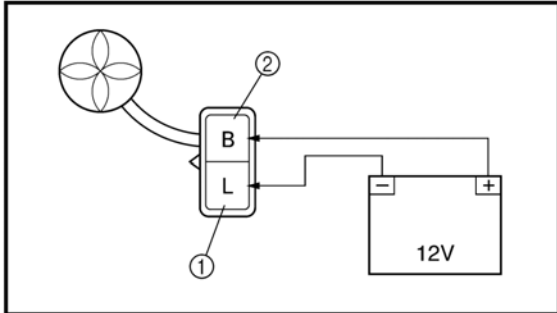

- Check the operation of the radiator fan motor.

DOES NOT TURN

Replace the radiator fan motor.

5. Thermo switch 3

- Remove the thermo switch 3 from the radiator.
- Connect the pocket tester ($\Omega \times 1$) to the thermo switch 3 ①.
- Immerse the thermo switch 3 in coolant ②.
- Check the thermo switch 3 for continuity. While heating the coolant use a thermometer ③ to record the temperatures.

A The thermo switch 3 circuit is closed.

B The thermo switch 3 circuit is open.

Test step	Coolant temperature	Continuity
1	Less than $75 \pm 3 \text{ }^\circ\text{C}$ ($167 \pm 5.4 \text{ }^\circ\text{F}$)	No
2	More than $75 \pm 3 \text{ }^\circ\text{C}$ ($167 \pm 5.4 \text{ }^\circ\text{F}$)	Yes
3	More than $68 \text{ }^\circ\text{C}$ ($154.4 \text{ }^\circ\text{F}$)	Yes
4	Less than $68 \text{ }^\circ\text{C}$ ($154.4 \text{ }^\circ\text{F}$)	No

Test steps 1 & 2: Heating phase

Test steps 3 & 4: Cooling phase

GOOD CONDITION

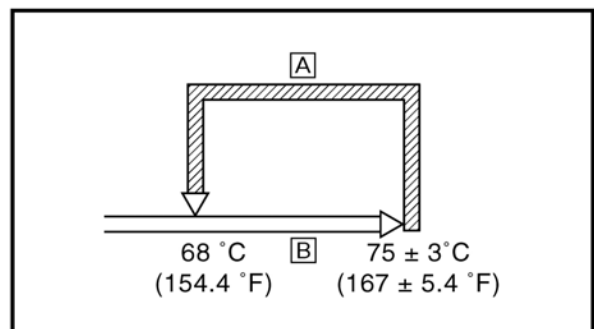
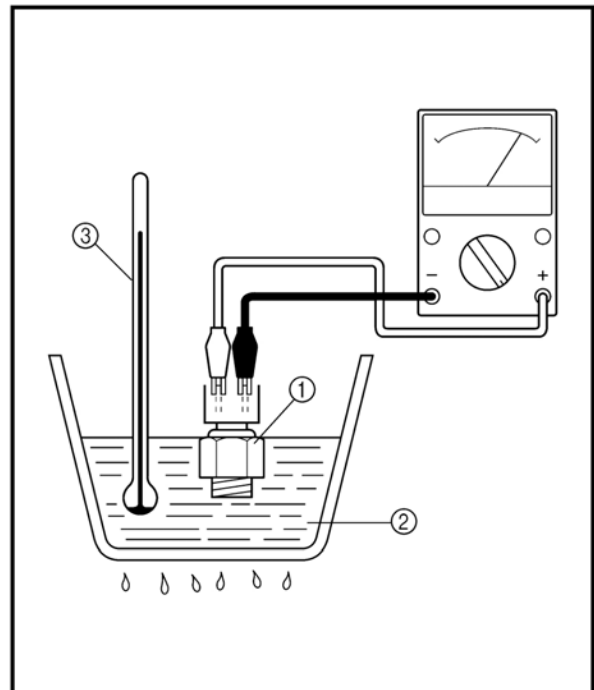

ELECTRICAL COMPONENTS

WARNING:

Handle the thermo switch 3 with special care.

Never subject it to a strong shock or allow it to be dropped. Should it be dropped, it must be replaced.

Thermo switch 3

28 Nm (2.8 m · kg, 20 ft · lb)

BAD CONDITION

Replace the thermo switch 3

6. Wiring connection

• Check the connections of the entire starting system. Refer to "CIRCUIT DIAGRAM"

CORRECT

This circuit is not faulty.

POOR CONNECTION

Properly connect the cooling system.

2WD/4WD SELECTING SYSTEM
CIRCUIT DIAGRAM (see 353 page)

ELECTRICAL COMPONENTS

TROUBLESHOOTING

1. Check if the 2/4WD switch is working.

- a. Turn on the switch, put the gear to position N; keep front and rear wheel off the ground , and then roll the front wheel to see if the rear wheel is moving together with it or if it is rotatable.
- b. After the actions above being done, and the wheels are rotatable, please check the electricity with multimeter, if has no electricity, please check the fuse.

2. Check if the rear differential is working.

- a. Check the sound. When the switch is turned on, the magneto valve will make s sound 'TA' to show that it is working and the rear wheel won't be able to rotatable at the same direction.
- b. If no sound is made, check if the controller of magnetic valve has a output of 12V electricity, and check if the magnetic valve has a input of 12V electricity,if it has the input, it means the valve doesn't work, please change for a new one ; if not , please check if the input end of controller has a input, if it has, change for a new controller, if not , check the fuse.

ENGINE MANAGEMENT SYSTEM

INTRODUCTION

EMS (Engine Management System)

EMS is a self contained set of components including a custom built computer and sensors and actuators which control the operation of an engine by monitoring the engine speed, load and temperature and providing the ignition spark at the right time for the prevailing conditions and metering the fuel to the engine in the exact quantity required.

Typical Components Of EMS

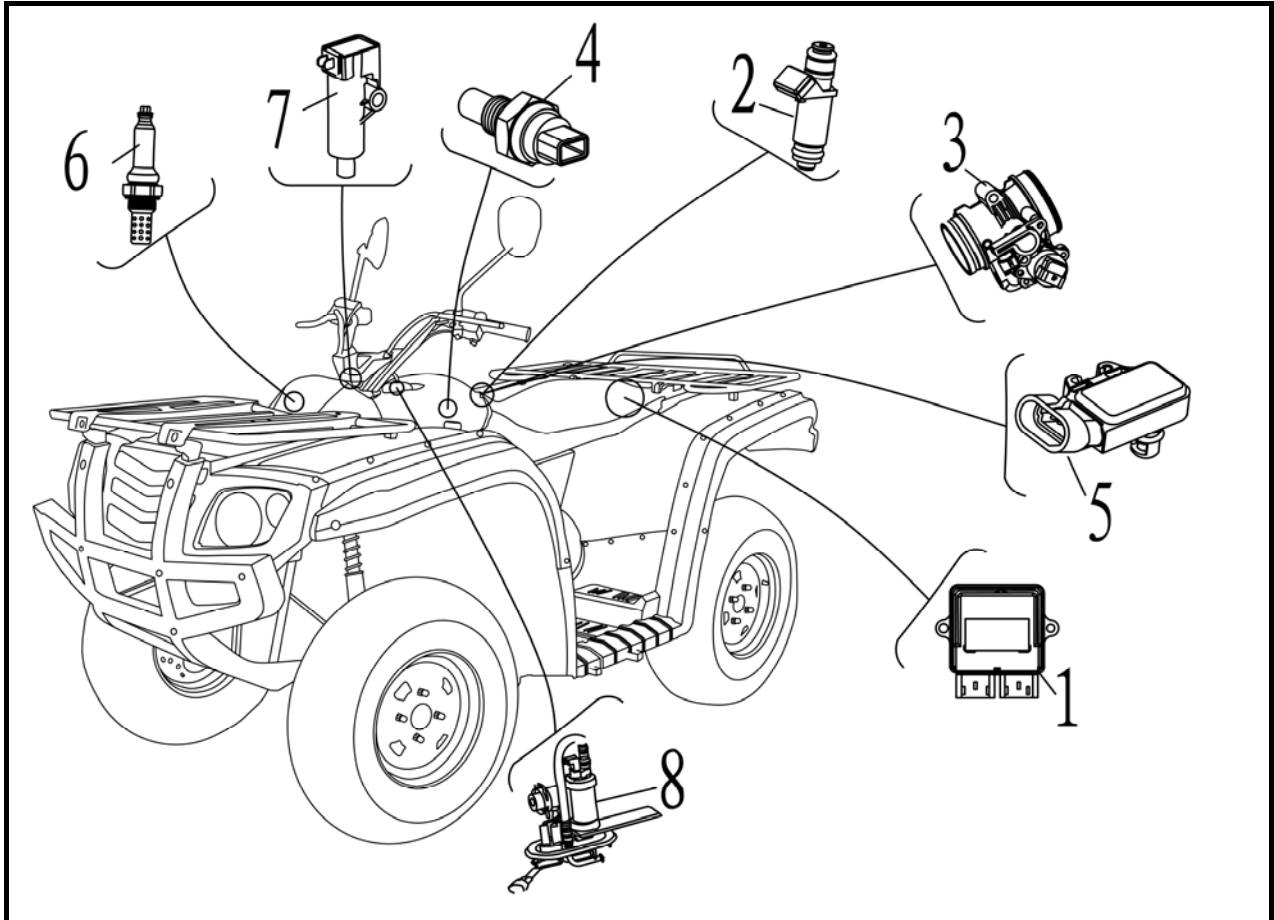

1. Electronic Control Unit
2. Multec 3.5 Injectors
3. Throttle Body Assembly (with stepper motor)
4. Engine Coolant Temperature Sensor
5. Intake Air Pressure and Temperature Sensor
6. Oxygen Sensor
7. Ignition Coil
8. Fuel Pump Module

ENGINE MANAGEMENT SYSTEM

Layout of EMS Components

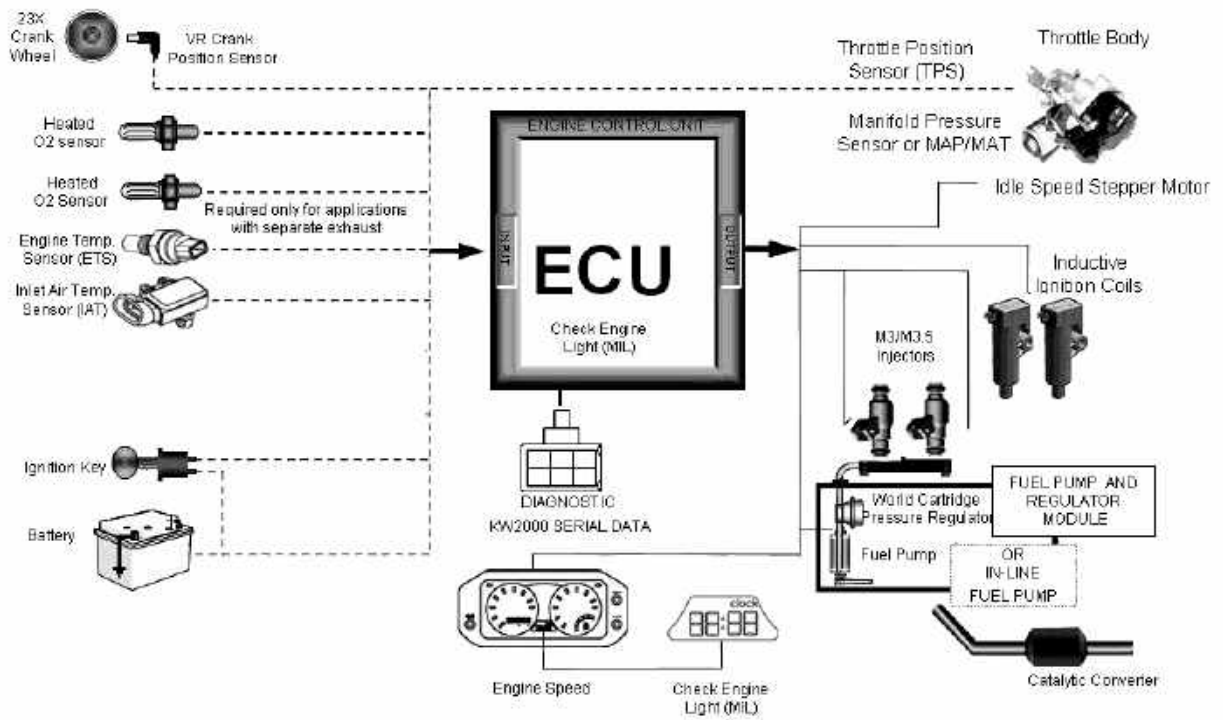

Legend:

----- Dotted line indicates inputs

————— Solid line indicates outputs

COMPONENTS OF EMS

Electronic Control Unit

1. Description & Working Principle

The ECU continuously monitors the operating conditions of the engine through the system sensors. It also provides the necessary computation, adaptability, and output control in order to minimize the tailpipe emissions and fuel consumption, while optimizing vehicle drivability for all operating conditions. The ECU also provides diagnosis when system malfunctions occur.

2. Handling – DOs & DONTs

ECU Handling	
ACTION	REASON
DO NOT: Place the ECU close to the exhaust pipe or Engine when removed	High temperature might reduce the life of the ECU and also can damage the ECU
DO NOT: Place the ECU close to or pour water, oil or any other liquids.	ECU is susceptible to water and liquids
DO NOT: Allow mud or other debris to accumulate on the surface of the ECU	Having mud or debris accumulated on the ECU casing reduces its heat dissipation efficiency.
DO NOT: Apply any voltage relative to any point to the ECU	Drastically affects the performance of the ECU and may lead to ECU damage
DO NOT: Clean ECU with any solvent or any corrosive liquid	Can damage the housing of the ECU
DO: Take extreme care that water droplets or excess moisture should not fall on ECU connectors	ECU connectors can get short and may lead to ECU damage
DO: Clean the ECU with a moist cloth and keep it dry	Prevents ECU damage

3. Installation requirements

The ECU shall be mounted using M5 machined screws with a torque of 3.9Nm \pm 10%. The mounting surface should also be flat to avoid subjecting the base plate to unnecessary force and warping the PCB.

4. Maintenance service and Repair

ECU is a non-serviceable part. Once there are problems, it's important to first determine if the problem is caused by software/calibration. If it is caused by software/calibration, please refer to software/calibration reflashing procedure. In the event of ECU hardware failure or malfunction (during warranty period only) the ECU should be sent back to the vehicle manufacturer giving complete details

ENGINE MANAGEMENT SYSTEM

of the ECU Part No, Serial number, Vehicle Model & Make, manufacturing Date, Total kms run on the vehicle, Location of use, Vehicle No, Date of return.

Multec 3.5 Injectors

1. Description and Working Principle

The Multec 3.5 Fuel Injector is an electromechanical device. A magnetic field is generated as voltage is applied to the solenoid coil. The resulting magnetic force lifts the core assembly, overcoming manifold vacuum, spring force, and fuel pressure, allowing fuel to pass through the ball and seat interface to the director. As the fuel passes through the director, an atomized spray is developed. The injector closes when the voltage is removed, cutting off the fuel flow.

2. Handling - DOs & DONTs

3.5 FUEL INJECTOR HANDLING	
ACTION	REASON
DO NOT: Re-use injector seal rings if at all possible. If no other choice exists, take extra care in inspecting the seal rings for damage.	Leakage.
DO NOT: Dip injector tips into lubricants.	Can plug injector spray orifices.
DO NOT: Cycle injector repeatedly without fuel pressure.	Damage to internal mechanical components.
DO NOT: Pulse (actuate) a suspected high leak rate injector (leak >50 sccm air).	Can dislodge internal contamination if present and preclude root cause analysis.
DO NOT: Allow water to enter fuel system from air lines, etc. during leak checks.	Can damage injectors.
DO NOT: Contact or apply load to the injector tip for installation.	Apply load to 45 deg angle on nylon over mold see
DO NOT: Pound injectors into manifold during assembly to engine.	Can damage injectors or seal rings.
DO NOT: Apply excessive side loads to electrical connectors.	May cause loss of electrical continuity.
DO NOT: Use any dropped unit.	Internal damage may have occurred.
DONOT: Store injectors, rails, or subassemblies including engines on which the injectors have been installed in an unprotected environment.	External contamination can damage the injector electrically and/or mechanically.
DO NOT: Use the injector as a handle.	Do not use the injector to lift assemblies

ENGINE MANAGEMENT SYSTEM

DO NOT: Rack, stage, or handle parts in a manner that allows contact between parts.	Damage will occur.
DO NOT: Remove packing in a way that allows contact between parts.	Damage could occur due to contact between parts.
DO NOT: Tap on fuel injectors to correct any malfunction.	Can damage injector.
DO NOT: Replace the injector with other part number not recommended for this application	Will severely affect the performance of the injector
DO: Take extra care when installing new fuel seal ring over injector inlet flange.	Prevent tearing seal ring during installation.
DO: Use proper lubricants on seal ring surfaces to install injector in engine. Minimize time between applying lubricant and inserting injector / rail.	Avoid damage to seal ring during installation. Avoid contamination at seal.
DO: Pulse (actuate) stuck closed or tip-leak suspected injector (Actuate consists of one pulse <5 sec duration at 9 to 15V).	To verify the injector failure
DO: Pulse (actuate) injectors prior to a dry fuel system leak test at engine/vehicle assembly to reseal injector valves.	Injector valves may not reseal without fuel after shipping and handling resulting in false leakage.
DO: Avoid any liquid contamination in the injector area.	Coil could short circuit.
DO: Use care during connection of harness to injector.	Avoid terminal damage.
DO: Use recommended terminal lubricant on mating connector.	Minimize potential for terminal fretting corrosion.
DO: Return any dropped, damaged, or suspect material with a tag that describes the problem.	Ensure fast and correct diagnosis of root cause.

3. Installation guidelines

Follow these guidelines to prevent damage to the injector and its electrical interface during the replacement or re-installation process.

- Lubrication: Apply a light coating of lubricant to the lower injector seal ring. ISO 10 light mineral oil or equivalent is recommended.
- The preferred technique is to apply the lubricant to the sockets the injectors are being installed into, rather than directly to the seal ring itself. This will help minimize the possibility of injector contamination.

ENGINE MANAGEMENT SYSTEM

- Avoid applying lubricant over the director plate holes – this may restrict injector flow. Do not dip the injector tip in lubricant.
- Multec 3.5 injectors come from the factory with the seal rings attached. The re-use of seal rings is not preferred when replacing an injector. If an injector is to be re-used, and no new seal rings are available, take care to inspect each seal ring for signs of damage. Even minor defects in the seal ring can lead to leakage. Take extra care in installing seal ring over flange of injector inlet.
- Carefully installing the harness connector will prevent terminal damage. Listen for a positive audible click from the connector retention device — this ensures that it is fully engaged. Shut off ignition.
- Disconnect negative battery cable to avoid possible fuel discharge if an accidental attempt is made to start the engine.
- Disconnect the electrical connector from the injector wiring harness.
- Relieve fuel pressure
- Remove the retaining clip from the fuel injector.
- Remove the fuel line connection from the injector
- Carefully clean debris from the interface surfaces. Do not damage seal mating surfaces.
- Remove the injector from the manifold
- Apply a light coating of a lubricant to both the upper and lower injector seal ring of the replacement injector.
- Install the new injector into the manifold. Check that the injector is installed in the original orientation to maintain proper spray targeting, and that the retaining clip is properly seated on the injector and the fuel line
- Install the retaining clip after connecting the fuel line
- Tighten the injector mounting to the desired torque as mentioned in the manufacturer manual
- Tighten the fuel line
- Re-install the injector electrical connector
- Check for fuel leaks with the key “on” and the engine “off”
- Start engine and verify proper operation.
- or spray pattern, do not rotate the injector in the fuel rail assembly to install the injector electrical connector. This may dislodge the retaining clip, and result in improper spray orientation

4. Replacement Techniques

WARNING:

The injector and all associated hardware may be extremely hot.

- Shut off ignition.
- Disconnect negative battery cable to avoid possible fuel discharge if an accidental attempt is made to start the engine.
- Disconnect the electrical connector from the injector wiring harness.

ENGINE MANAGEMENT SYSTEM

- Relieve fuel pressure
- Remove the retaining clip from the fuel injector.
- Remove the fuel line connection from the injector
- Carefully clean debris from the interface surfaces. Do not damage seal mating surfaces.
- Remove the injector from the manifold
- Apply a light coating of a lubricant to both the upper and lower injector seal ring of the replacement injector.
- Install the new injector into the manifold. Check that the injector is installed in the original orientation to maintain proper spray targeting, and that the retaining clip is properly seated on the injector and the fuel line
- Install the retaining clip after connecting the fuel line
- Tighten the injector mounting to the desired torque as mentioned in the manufacturer manual
- Tighten the fuel line
- Re-install the injector electrical connector
- Check for fuel leaks with the key “on” and the engine “off”
- Start engine and verify proper operation.

5. Plugging

Fuel deposits cause plugging resulting in flow shifts over the life of the injector. Fuel varnish or gumming, a type of injector deposit, is created when certain types of fuel are heated by high injector tip temperatures at soak (no fuel flow). Deposit build up in the injector holes causes the flow shifts

- Plugging can cause flow restrictions, frictional changes and the collection of other particles attracted by the tacky surface. The flow restrictions can degrade emissions and drivability.
- Other fuel and environmental conditions may cause crystal or corrosion growth in the injector and cause a flow shift.
- Oxidation stability of the gasoline affects the potential for deposit formation and must be controlled by the fuel supplier.
- Increased levels of detergent additives reduce the rate of injector plugging.
- In case of plugging of injector follow the injector cleaning procedure mentioned in the section below

6. Cleaning Procedure

- Electrically disable the fuel pump by removing the fuel pump connection.
- Relieve the fuel pressure in the system and disconnect the fuel connection at the injector. Plug the fuel feed line.
- Injector cleaner with the specific ratio of the cleaner and gasoline to be mixed in the Injector cleaning tank.
- Connect the injector-cleaning tank to injector in the vehicle.
- Pressurize the injector-cleaning tank to system pressure.
- Start and idle the engine for 15- 20 minutes.
- Disconnect the injector-cleaning tank from the system and install the fuel pump connections. Connect the fuel feed line to injector.

ENGINE MANAGEMENT SYSTEM

- Start and idle the vehicle for an additional 2 minutes to ensure the residual injector cleaner is flushed from system.

Throttle Body Assembly(with stepper motor)

1. Description and Working Principle

The Throttle Body Assembly is an interactive system comprised of the following subsystems: the main casting body, bearing system, shaft and valve system, return spring system, cable interface system, throttle position sensing system, and the bypass air control system. The subsystems interact and support each other to provide all the functional requirements, which are mentioned below -

- Control intake air flow
- Control idle air flow
- Sense throttle position - Provide position feedback to Engine Controller
- Provide reactionary force to the throttle

ENGINE MANAGEMENT SYSTEM

2. Handling – DOs and DONTs

THROTTLE BODY ASSEMBLY HANDLING	
ACTION	REASON
DO: Use care during assembly of harness to throttle body.	Avoid terminal damage.
DO: Avoid any liquid contamination in the throttle body area.	Ensure proper operation.
DO: Unload and install units one at a time from packing trays.	Damage may be done to critical components.
DO: Return any dropped, damaged, or suspect material with a tag that describes the problem. (Only warranty cases)	Ensure fast and correct diagnosis of root
DO: Remove and discard protective caps just before assembling mating components.	Protects system from contamination, which can prevent proper operation.
DO: clean the by pass passage after removing bottom cover	To ensure good idle stability
DO NOT: Use any dropped or impacted unit.	Internal damage may have occurred or emissions settings may have been upset.
DO NOT: Store units without protective caps in place.	Contamination may impair correct operation.
DO NOT: Ship or store near saltwater without protection.	Corrosion buildup may impact proper operation.
DO NOT: Exposed to environmental conditions (Moisture) prior to complete vehicle installation.	Corrosion buildup may impact proper operation.
DO NOT: Apply any voltage other than system voltage for testing.	Damage could occur.
DO NOT: Apply excessive band clamp loading	Damage could occur.
DO NOT: Remove packing in a way that allows contact between parts.	Minimum air leakage could be affected and/or other damage could occur.
DO NOT: Release the throttle cam abruptly from any position without the throttle linkage attached.	Damage could occur.
DO NOT: Let the by pass holes be blocked by dirt or foreign particles.	This could effect idle stability
DO NOT: Rake, stage, or handle parts in a manner that allows contact between parts.	Damage will occur.

3. Throttle Body Removal

- Disconnect negative terminal of the battery

ENGINE MANAGEMENT SYSTEM

- Disconnect electric lead wire of throttle position sensor coupler, stepper motor coupler and MAP/MAT sensor coupler (if this sensor is mounted on the throttle body)
- Disconnect accelerator cable from throttle body
- Remove air cleaner outlet hose and throttle body outlet hose

4. Cleaning Procedure

If there is cover on the bottom, it may be removed and cleaned using carburetor cleaner (3M make recommended). Once the throttle body cover is removed, spray the throttle-body cleaner inside the shipping air passage, and use the brushes to gently dislodge the dirt, gum and varnish that are present. Do not let the by pass holes be blocked by dirt or foreign particles.

5. Throttle Body Installation

- Reverse the procedure for installation noting the following:
- Adjust accelerator cable play
- Check to ensure that all removed parts are back in place. Reinstall any necessary part which have not been reinstalled

6. Precautions

- Do not submerge TPS in any cleaning fluid.
- Always open the throttle valve using the throttle cable or lever.
- Do not hold the valve at opening position by inserting tools or any sticks into the bore. The valve may be warped and the bore may be scratched. This type of damage may keep the throttle from opening easily or fully closing.

Engine Coolant Temperature Sensor

1. Description and Working Principle

This sensor is used in water cooled engines. It provides a resistance that varies as a function of temperature within prescribed tolerance limits. The sensor has a negative temperature coefficient of resistance. This is a non-serviceable part.

2. Installation Requirements

- **Dynamic Torque Requirement:** The sensor shall be hand into the application and then driven by a driver with a maximum no load speed of 400 rpm or installed to the desired torque by a hand torque wrench (5/8" hex). The recommended installation torque is: Minimum: 20 N·m
Maximum: 25 N·m
- **Static Torque Requirement:** The torque required to remove the sensor from the mating hole shall be within 200% of the installation torque mentioned above.

3. Sample Cleaning

- When necessary the samples may be cleaned in isopropyl alcohol for one minute with mating connectors in place and then air-dried

Intake Air Pressure and Temperature Sensor

1. Description and Working Principle

This sensor has two functions. The first is the intake manifold air temperature, it provides a resistance that varies as a function of temperature within prescribed tolerance limits. The second is the intake manifold air pressure; it provides a voltage varies as the intake air pressure.

2. Sample Cleaning

- When necessary the samples may be cleaned in isopropyl alcohol or gasoline for one minute with mating connectors in place and then air-dried

Oxygen Sensor

1. Description and Working Principle

This sensor is a device for monitoring the residual oxygen in the exhaust of an internal combustion engine. It consists of the wide range sensor and stoichiometric sensor. Usually we use stoichiometric sensor on the small engine. It is the feedback element for engine closed loop control.

2. Installation Requirements

- Mounting Angle with Level: ≥ 10 degree
- Tightening Torque Requirement: 40-60 Nm

Ignition Coil

1. Description and Working Principle

This coil provides energy to the spark plug in the combustion chamber. The coil itself doesn't have a driver. The high voltage tower of the coil is connected to the spark plug using a high voltage cable assembly. This is a non-serviceable component.

2. Installation requirements

- The vehicle frame provides the mounting surface and mounting holes.
- Mount coil close to the spark plug and keep the plug wire length very short (less than 6").
- Mount coil away from any pick coil device. Especially, a VR type Crank / Cam sensor. Keep a Min distance of 150 mm (around 6") between coil and any VR sensor device.
- Never route the coil C- wire with the same bundle as the Crank sensor wires. There is around 200 V peak potential between C- wire and engine ground. This voltage potential could cause a noise on sensor cables.

ENGINE MANAGEMENT SYSTEM

3. DOs and DONTs

Ignition Coil Handing	
Action	Reason
DO NOT: Install the low voltage connectors with the power applied	This might cause an unwanted secondary firing, possibly leading to personal injury
DO NOT: Use a screw driver to asset in removing secondary boots from the secondary tower. Use tools designed for secondary removal.	It is possible to damage a secondary lead in such a manner that creates an electrical path to outside the system permitting improper system operation misfire, or even possible personal injury if arcing occurs.
DO NOT: Use parts that have been dropped or display physical damage	Damaged components can lead to premature failure.
DO NOT: Scratch or apply any non approved material to the surface of the high voltage tower which mates with the high voltage secondary leads.	This can jeopardize the seal integrity of the mating surfaces which in turn can create a secondary high voltage leak path.
DO NOT: Strike any part of the ignition system with a tool or other object.	This can lead to physical damage which can cause a system malfunction or failure.
DO NOT: Permit paint or other sprayed materials to be sprayed onto the electrical connectors.	Insulating type sprays can create a high resistance or open connection. And, a conductive type spray can create an electrical short condition.
DO NOT: Support the ignition system by the wiring harness or plug wire.	These leads are not designed to support the weight of the ignition system. It can create a poor electrical connection Or become disconnected allowing the system to fall and be subjected to physical damage
DO NOT: Pierce or probe the secondary leads.	This creates an electrical path to outside the system permitting improper system operation, misfire, or even possible personal injury if arcing occurs.
DO NOT: Operate without the spark plug attached.	If a technician or mechanic comes in contact with the high voltage generated during operation, personal injury may occur. Or, if the engine is operated under this condition, unburned fuel may fill the converter area creating a potential hazard
DO NOT: Share ignition component wiring with other components, Dedicated wiring is required.	This prevents electrical cross talking between components which can lead to component malfunction.
DO NOT: Apply voltage to the ignition system other than vehicle system voltage for testing	This can cause reduced performance or an electrical malfunction of the ignition system.

ENGINE MANAGEMENT SYSTEM

purposes.	
DO NOT: Use high impact tools to apply the spark plug boot to the ignition secondary towers. Installation of the high voltage secondary leads by hand is preferred.	Damage to the coil tower, secondary boot, or mating connection surfaces might occur.
DO: Install the secondary leads before connecting the primary leads.	In the event the low voltage connection has been made and the power applied, unwanted secondary output might occur possibly resulting in injury, damage the ignition component, and test equipment
DO: Take care when working around the ignition system.	The high voltage produced by the coil secondary circuit can cause personal injury and/or damage test equipment
DO: Proper handling and shipping methods need to be in place to reduce the risk of damage due to impact, moisture, or contamination	Damaged components can lead to premature failure.
DO: Avoid unnecessary disconnecting and connecting of the electrical components.	The electrical connections are not designed for repeated connection and disconnection.
DO: Insure the low voltage connectors are entirely seated and the locking mechanism is engaged.	This prevents intermittent electrical connections leading to an improper ignition system operation.
DO: Use approved connector breakouts when testing the ignition system.	Connector and/or component damage may occur.
DO: Insure the appropriate seals are included in the connector system.	Liquid intrusion into the terminal connection area might occur causing an electrical intermittent or short condition. In the event of severe terminal corrosion, an open condition might occur.
DO: Operate with gasoline based internal combustion engines.	Other fuels or combustion designs may require additional design considerations.
DO: The power feed line should be fused.	This could protect the system in the event of an electrical short
DO: The module heat sink and back plate must not be used as a connection point when jump starting the engine	The high level of voltage and current which the module could be subjected to, could cause module performance degradation or failure.
DO: Connection of the module back plate to vehicle ground is desirable whenever possible	This greatly reduce potential ground loops and acts as a heat transfer source from the module.
DO: The ignition system ground wire should be kept as short as possible. And, when permissible, should be grounded at the same engine block position as the engine controller	This would greatly reduce the possible of unwanted electrical ground loops.
DO: The electrical wiring to the ignition system should be routed so that the conductors are	Helps prevent electrical intermittent, open or shorted operating conditions.

ENGINE MANAGEMENT SYSTEM

protected from excessive heat, damage, and wear.	
DO: Ignition secondary leads should not be routed with the ignition primary harness or any other electrical harness.	Voltage spikes can be transmitted from the secondary cables into other leads which are in close. This could create a component performance degradation or failure condition
DO: Spark plug wires(secondary leads) & primary wiring: <ul style="list-style-type: none"> - must not contact sharp surface - must not be under tension between fixed points - must be clear of moving parts (belts, fan, etc...) - must be protected from or kept at least 125 mm away from radiant heat source exceeding 400 F. - must be protected from environmental damage (dirt, splash, oils, fluids, etc...) - must be retained, secured or insulated to prevent pinching, mis-routing, rattles, and squeaks 	- Spark plug wires carry very high voltage (30,000 volt). If the secondary lead loses its dielectric characteristics thru being nicked, cut, chaffed, then an arc thru to a near by ground could take place. This kind of condition could lead to misfire, no start, or premature failure of ignition system.
DO: Not all fasteners are designed for repeat use. Beware of fastener specifications. All harnesses should be supported within 6" of a mating connection.	Adequate retention force might not be achieved if the fastener is not designed to be reused. Mating connections are not designed to support the weight of the harness assembly.
DO: For removing spark plugs follow the following steps: <ol style="list-style-type: none"> 1- Grasp the spark plug boot and gently 2- rotate 90°; and then pull the spark plug boot and cable away from the spark plug 3- Before removing spark plug, brush or air blast dirt away from the well areas 4- Use correct size deep socket wrench to loosen each spark plug one or two turns 	To remove spark plugs from Aluminum heads, allow the engine to cool. The heat of the engine, in combination with a spark plug that is still hot, may cause the spark plug threads to strip the cylinder head upon removal Use goggles to protect eyes from dirt when applying compressed air to spark plug wells
DO: Cleaning a spark plug could be done as follow: <ol style="list-style-type: none"> 1- wipe all spark plug surfaces clean....remove oil, water, dirt and moist residues. 2- If the firing end of spark plug has oily or wet deposit, brush the spark plug in an approved, non-flammable and non-toxic solvent. Then dry the spark plug thoroughly with compressed air 3- Use a propane torch to dry wet-fuel fouled plugs. Allow the torch flame to enter up the center electrode insulator. Allow plug to cool 	-Cleaning a spark plug will reduce the voltage required for an electrical arc(spark) across the electrodes <ul style="list-style-type: none"> -Cleaning & re-gapping will not restore a used spark plug to a new condition. It may be more economical and efficient to replace used spark plugs with new plugs instead of cleaning. -Sooted plugs should be replaced -Do not cool by using water or any liquid -Clean threads permit easier installation and proper seating which will maximize transfer heat away from the plug

ENGINE MANAGEMENT SYSTEM

down	
4- If the spark plug threads have carbon & scale deposits, clean with wire brush, taking care not to injure the electrode or the insulator tip.	
DO: Regap spark plugs to the exact measurement specified by the engine	-Too wide a gap could cause the plug to misfire(higher required ignition voltage).
manufacturer to keep the best fuel economy and proper engine performance - Use round wire-type gauge for an accurate measure of gap on all used spark plugs - when gapping a spark plug only the side electrode is moved. The center electrode must not be moved	-Too narrow of a gap could affect idle stability -A flat gauge can't accurately measure the spark plug on used plugs
DO: When replacing spark plugs with new ones, always use equivalent plugs with same heat range, thread, size, etc....	-Higher heat range plug(hotter plug) could lead to pre-ignition & possible piston damage -Lower heat range (colder plug) could lead to cold fouling & emission problem
DO: For installing spark plugs follow the following steps: 1- make sure the cylinder head threads and spark plug threads are clean. Make sure the spark plug thread is free of dings and burrs. If necessary, use a thread chaser and seat cleaning tool. 2- Make sure the spark plug gasket seat is clean, then thread the gasket to fit flush against the gasket seat. Tapered seat plugs do not require gaskets 3- Screw the spark plugs finger-tight into the cylinder head. Then, use a torque wrench to tighten spark plugs following manufacturer's recommendation). Torque is different for various plug type & cylinder head material	-If the thread is damage, it prevents a good heat transform from the shell to the cylinder head -Do not use any type of anti-seize compound on spark plug threads. Doing this will decrease the amount of friction between the threads. The result of the lowered friction is that when the spark plug is torqued to the proper specification, the spark plug is turned too far into the cylinder head. This increases the likelihood of pulling or stripping the threads in the cylinder head -Over-tightening of a spark plug can cause stretching of the spark plug shell and could allow blowby to pass thru the gasket seal between the shell and insulator. Over-tightening also results in extremely difficult removal

Fuel Pump Module

1. Description and Working Principle

Fuel Pump Module supplies fuel to engine at system pressure. Fuel Pump Module is mounted to fuel tank at bottom and supplies fuel to engine through hoses.

Fuel Pump module consists of Fuel Pump to generate the fuel flow and pressure regulator to regulate the fuel pressure.

ENGINE MANAGEMENT SYSTEM

Fuel Pump

When power is supplied to fuel pump, motor in pump assembly rotates the impeller. Impeller in turn draws the fuel from strainer and pumps the flow to generate the system pressure.

Pressure Regulator

Pressure Regulator is a diaphragm type mechanical device. Fuel flow from filter enters in the inlet of pressure regulator. Pressure regulator regulates the fuel pressure at a set pressure by releasing the excessive fuel flow to fuel tank.

2. Service Procedure:

Precautions:

Before attempting any service on fuel system, following cautions should be always followed for personal safety and to avoid system damages.

- Disconnect negative cable at battery.
- DO NOT smoke, and place 'No SMOKING' sign near work area
- Make sure to have fire extinguisher handy.
- Make sure to perform work in well ventilated area and away from any open fire/flames.
- Wear Safety glasses
- To relieve fuel vapor pressure in fuel tank, remove fuel filler cap fuel filler neck and then reinstall it.
- As fuel lines are at high pressures when the engine is stopped, loosening or disconnecting fuel line will cause dangerous spout of fuel. Before loosening/ disconnecting fuel lines, please follow the "Fuel Pressure Relief Procedure" described in this section.
- Small amount of fuel may drip after the fuel lines are disconnected. In order to reduce the risk of personal injury, cover the pipe/ hose ends with suitable blind with no rust or contamination.
- After servicing, make sure that the fuel hoses and clamps are connected according to the hose fitment instructions given in vehicle instruction manual.
- After servicing, please follow the 'Fuel Leakage Check Procedure' described in this section.
- After servicing make sure to fill at least 3 liters gasoline before pump is primed (ignition key should be turned on only after ensuring there is minimum 3 liters of fuel in the fuel tank)

Fuel Module Diagnosis:

Step	Action	Yes	No
1	Switch on Ignition key. Fuel Pump primes for 3 seconds when the ignition key is ON. Check for fuel pump running noise for 3 seconds after ignition key is ON.	If fuel pump running noise can be heard, go to step 4.	If fuel pump running noise can not be heard, go to step 2.

ENGINE MANAGEMENT SYSTEM

2	Disconnect fuel module coupler. Check voltage at harness coupler. Is the voltage within 10-14V	Go to step 3	Check the electrical circuit from Ignition to fuel module.
3	Connect 12V DC power supply (battery) to fuel module. Make sure that enough fuel available in fuel tank to avoid fuel pump running dry. Is the fuel pump running	<ol style="list-style-type: none"> 1. Check electrical circuit from fuel module to ECU 2. Check ECU 	<ol style="list-style-type: none"> 1. Check Fuel Pump Harness integrity 2. Check Fuel Pump
4	Check fuel system pressure at Injector inlet (with a T-joint) while engine is running in idle condition. Is the pressure between 220 ~ 270kPa?	Fuel Module Operation Normal	Go to Step 5
5	Is the Pressure below 220kPa?	<ol style="list-style-type: none"> 1. Check for leakages from hoses, hose joints 2. Check Fuel Pump 3. Check Pressure Regulator 	<ol style="list-style-type: none"> 1. Clogged Filter 2. Kink/ Blockage in Fuel Hoses 3. Check Regulator

3. Fuel Module Removal:

- Relieve fuel pressure in fuel lines referring to the 'Fuel Pressure Relief Procedure' provided in this section.
- Disconnect negative cable at battery.
- Disconnect fuel module wire coupler.
- Drain the fuel in fuel tank thru fuel filler with help of hand pump (siphon). Collect the fuel in approved container for contamination and safety.
- Disconnect the fuel hoses from fuel module by using standard tools
- Remove the fuel tank from vehicle.
- Place the fuel tank with bottom up condition. Care to be taken not to cause any scratches/ damages on fuel tank.
- Open the fuel module mounting bolts.
- Take out fuel module assembly from fuel tank with care
- Care to be taken not to damage the strainer while removing fuel module from tank.

4. Fuel Module Installation:

- Replace the fuel module gasket in fuel module assembly with a new one. Old/ used gaskets can cause leakages.
- Fold strainer towards fuel pump and insert fuel module in tank opening with care. Care should be taken not to cause any damages on strainer.

ENGINE MANAGEMENT SYSTEM

NOTE

Fuel Module Orientation: Fuel module bolts not symmetrical and can be mounted only in the intended direction. Regulator side should be facing the Fuel Tank rear side. Make sure that the fuel tank surface at module mounting area is clean and free of surface defects.

- Place the bolts on module cover and tighten the bolts gradually in star pattern sequence to apply equal compression on gasket. It is shown in figure as below. Bolt Tightening Torque: 3~4 Nm.

Fuel module is installed with special bolts (step bolts). Use designated bolts only. Follow the tightening torque and tightening sequence instruction. Over torque and miss-sequence can cause unequal compression of gasket and leakage.

- Install the fuel tank to vehicle.
- Connect for fuel hoses with suitable hose clamps.
- Connect fuel module coupler.
- Follow "Fuel Leakage Check Procedure" to check any leakage before the engine is started.

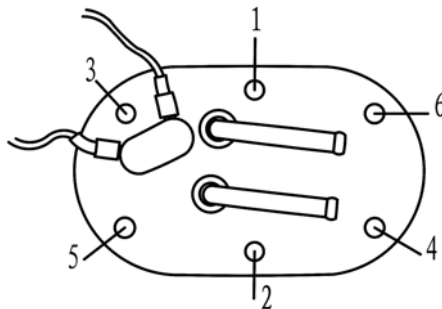

Mounting Bolts – Star Tightening Pattern

5. Pressure Regulator Assembly Replacement:

- Remove the regulator retainer from module.
- Apply gradual pull force on retainer to avoid any personal injury due to spring action of retainer.
- Take out the pressure regulator assembly from module.
- Do not hit/ damage on the regulator dome and crimping portion.
- Lubricate the O-rings in new pressure regulator assembly with recommended lubrication oils as mentioned in Table no: 3. Lubrication oil is applied only for ease of regulator assembly.
- Make sure that 2 O-rings (one is bigger diameter the other is smaller diameter) are assembled in pressure regulator.
- Place the pressure regulator on module at regulator pod. Push the regulator gently in the pod.
- Do not hit/ damage on the regulator dome and crimping portion. This will disturb the pressure setting.
- Assemble the retainer on the regulator pod
- Replace the gasket, module with new gasket provided in the kit.

ENGINE MANAGEMENT SYSTEM

6. Fuel Pressure Relief Procedure:

NOTE

This work must not be done when engine is hot. If done so, it may cause adverse effect to catalyst (if equipped)

After making sure that engine is cold, relieve fuel pressure as follows.

- Place vehicle gear in 'Neutral'.
- Disconnect fuel module electrical coupler from vehicle harness.
- Start engine and run till it stops due to lack of fuel. Repeat ignition key ON and OFF for 2 ~ 3 times of about 3 seconds each time to relieve fuel pressure in lines. Fuel Connections are now safe for servicing.
- Upon the completion of servicing, Connect Fuel Module Connector to Vehicle Harness.

7. Fuel Leakage Check Procedure:

After performing any service on fuel system, check to make sure that there are no fuel leakages as below.

- Fill about 3 ~ 5 liters of fuel in tank.
- Turn Ignition key to ON position for 3 seconds (to operate fuel pump) and then turn to OFF position. Repeat this for 3 ~ 4 times to apply fuel pressure in fuel lines.
- In this state, check to see that there are no fuel leakage from any part of fuel system (Fuel Tank, Hoses, Hose Joints, etc)

8. Handling – DOs and DONTs:

FUEL MODULE HANDLING	
ACTION	REASON
DO NOT: Drop Fuel Module on Floor	Could cause internal damage to Fuel Pump.
DO NOT: Run Fuel Pump Dry (without fuel at pump inlet/ strainer) ensure atleast 3 litres of gasoline is present in the fuel tank	Caused internal damage to Fuel Pump
DO NOT: Damage the strainer during servicing, insertion of fuel module in fuel tank.	Contamination enters fuel pump thru damaged strainer damages the Fuel Pump
DO NOT: Disassemble Fuel Pump and regulator internal parts out side Delphi premises. DO NOT: Do any adjustments on pressure regulator and pump except for replacement.	Warranty void.

ENGINE MANAGEMENT SYSTEM

<p>DO NOT: Use module harness for hold/carry fuel module.</p> <p>DO NOT: Pull Wiring Harness in vertical direction to module cover</p>	<p>Wiring Harness Breakage/ Fuel Pump Power disconnection</p>
<p>DO NOT: Use damaged/ distorted hose clamps.</p>	<p>Can cause fuel seepage/ leakage.</p>
<p>DO NOT: Use Fuel Module if the strainer with excessive damage/ cut.</p>	<p>Contamination enters fuel pump thru damaged strainer damages the Fuel Pump</p>
<p>DO NOT: Use Fuel Pump for draining fuel in fuel tank.</p>	<p>Not intended function of fuel module.</p>
<p>DO NOT: Use module mounting bolts for mounting other components.</p>	<p>Affects fuel module sealing.</p>
<p>DO NOT: Damage fuel pump harness while servicing fuel module.</p>	<p>Damaged terminals will cause intermittent/ No contact for power supply.</p>
<p>DO NOT: Force hand pump towards fuel module while draining fuel from tank.</p>	<p>To avoid any damages on fuel module.</p>
<p>DO : Ensure that there are no damages to fuel pipes while servicing fuel module</p>	<p>Can cause fuel seepage/ leakage.</p>
<p>DO: Use genuine module gasket only.</p>	<p>Spurious gaskets can cause leakages.</p>
<p>DO: Use designated hose clamps.</p>	<p>To ensure no leakages/ seepages thru hose joint.</p>
<p>DO: Clamp fuel module harness to vehicle chassis</p>	<p>Clamp provides mechanical support for wiring harness in vibrations.</p>
<p>DO: Use only standard gasoline for operating vehicle/ module.</p>	<p>Fuel Module is intended to run in standard gasoline. Adulterated fuel can cause fuel module premature failures which are not covered under warranty.</p>
<p>DO: Change the fuel filter at recommended intervals.</p>	<p>Clogged fuel filter will cause restriction in fuel flow and can cause flow reduction.</p>
<p>DO: Use fuel filters supplied/ recommended fuel filters only.</p>	<p>Spurious fuel filters causes damages to injector, regulator and fuel pump performance.</p>
<p>DO: Ensure that the hoses are routed properly and there are no kinks / rubbing with other components.</p>	<p>Improper routing, kinks and fouling of hoses with other components causes hose damage</p>
<p>DO: Ensure that always sufficient fuel till the strainer height</p>	<p>Avoids Pump running in dry</p>

ENGINE MANAGEMENT SYSTEM

DO: Replace two O-rings along with replacement/re-installation of pressure regulator.	For proper functioning of regulator.
DO: Use care during connection of harness to module coupler.	Avoid terminal damage.
DO: Return any dropped, damaged, or suspect material with a tag that describes the problem.	Ensure fast and correct diagnosis of root cause.

EMS FAULT DIAGNOSIS

EME Fault Diagnosis

When fault comes up, the odometer's clock will turn into a number, which is a fault code, find out the cause with this number; press clock button, then it will turn back to clock mode, and five seconds later, the fault code will show again.

Fault code list

System or Component	DTC Number	DTC Description	Related Calibration
Manifold Absolute Pressure Sensor (MAP)	0107	MAP Circuit Low Voltage or Open	KsDGDM_MAP_ShortLow
	0108	MAP Circuit High Voltage	KsDGDM_MAP_ShortHigh
Intake Air Temperature Sensor (IAT)	0112	IAT Circuit Low Voltage	KsDGDM_IAT_ShortLow
	0113	IAT Circuit High Voltage or Open	KsDGDM_IAT_ShortHigh
Coolant/Oil Sensor	0117	Coolant/Oil Temperature Sensor Circuit Low Voltage	KsDGDM_CoolantShortLow
	0118	Coolant/Oil Temperature Sensor Circuit High Voltage or Open	KsDGDM_CoolantShortHigh
Throttle Position Sensor (TPS)	0122	TPS Circuit Low Voltage or Open	KsDGDM_TPS_ShortLow
	0123	TPS Circuit High Voltage	KsDGDM_TPS_ShortHigh
Oxygen Sensor	0131	O2S 1 Circuit Low Voltage	KsDGDM_O2_1_ShortLow
	0132	O2S 1 Circuit High Voltage	KsDGDM_O2_1_ShortHigh
Oxygen Sensor Heater	0031	O2S Heater Circuit High Voltage	KsDGDM_O2_HeaterShortHigh
	0032	O2S Heater Circuit Low Voltage	KsDGDM_O2_HeaterShortLow
Fuel Injector	0201	Injector 1 Circuit Malfunction	KsDGDM_INJ_CYL_A_Fault
	0202	Injector 2 Circuit Malfunction	KsDGDM_INJ_CYL_B_Fault
Fuel Pump Relay (FPR)	0230	FPR Coil Circuit Low Voltage or Open	KsDGDM_FPP_CircuitShortLow
	0232	FPR Coil Circuit High Voltage	KsDGDM_FPP_CircuitShortHigh

ENGINE MANAGEMENT SYSTEM

Crankshaft Position	0336	CKP Sensor Noisy Signal	KsDGDM_CrankNoisySignal
Sensor (CKP)	0337	CKP Sensor No Signal	KsDGDM_CrankNoSignal
Ignition Coil	0351	Cylinder 1 Ignition Coil Malfunction	KsDGDM_EST_A_Fault
	0352	Cylinder 2 Ignition Coil Malfunction	KsDGDM_EST_B_Fault
Idle Control System	0505	Idle Speed Control Error	KsDGDM_IdleControl
System Voltage	0562	System Voltage Low	KsDGDM_SysVoltLow
	0563	System Voltage High	KsDGDM_SysVoltHigh
MIL	0650	MIL Circuit Malfunction	KsDGDM_MIL_Circuit
Tachometer	1693	Tachometer Circuit Low Voltage	KsDGDM_TAC_Circuit_Low
	1694	Tachometer Circuit High Voltage	KsDGDM_TAC_Circuit_High
Oxygen Sensor 2	0137	O2S 2 Circuit Low Voltage	KsDGDM_O2_2_ShortLow
	0138	O2S 2 Circuit High Voltage	KsDGDM_O2_2_ShortHigh
Oxygen Sensor Heater 2	0038	O2S Heater 2 Circuit High Voltage	KsDGDM_O2_HeaterShortHigh
	0037	O2S Heater 2 Circuit Low Voltage	KsDGDM_O2_HeaterShortLow
Vehicle Speed Sensor	0500	VSS No Signal	KsDGDM_VSS_NoSignal
Park Neutral Switch Diag	0850	Park Neutral Switch Error	KsDGDM_ParkNeutralSwitch
CCP	0445	CCP short to high	KsDGDM_CCP_CircuitShortHigh
	0444	CCP short to low/open	KsDGDM_CCP_CircuitShortLow
BLM MaxAdapt	0171	BLM Max Adapt(Kohler Special)	KsFDIAG_BLM_MaxAdapt
BLM MinAdapt	0172	BLM Min Adapt(Kohler Special)	KsFDIAG_BLM_MinAdapt
PE system Lean	P0174	PE syst Lean(Kohler Special)	KsFDIAG_PESystLean

TROUBLESHOOTING

NOTE:

The following trouble, not including all possible troubles, is a help for trouble guide. Please refer to relevant contents for the inspection, adjustment and replacement of part.

STARTING FAILURE/HARD STARTING

FUEL SYSTEM	
Fuel tank	<ol style="list-style-type: none"> 1、 No oil 2、 Fuel filter is clogged 3、 Fuel pump filter net is clogged 4、 Breather tube is clogged 5、 Fuel is deteriorated or polluted
Fuel pump	<ol style="list-style-type: none"> 1、 Clogged fuel hose 2、 Damaged vacuum hose
Air filter	Clogged air filter element
Gasoline filter	Block up
ELECTRICAL SYSTEM	
Spark plug	<ol style="list-style-type: none"> 1、 Improper plug gap 2、 Worn electrodes 3、 Wire between terminals broken 4、 Wrong Spark plug heat value 5、 Faulty spark plug cap 6、 High voltage wires strapped on frame cause shortage of high pressure ignition energy
EFI system	<ol style="list-style-type: none"> 1、 Broken ECU 2、 Clogged nozzle or the rupture the line from nozzle to ECU 3、 Damage of engine speed signal sensor 4、 Rupture of the line from engine speed signal sensor to ECU 5、 Broken inlet pressure or temperature sensor or damaged line to ECU 6、 Broken air throttle or damage line to ECU. 7、 Broken vice line (cable) of electrical injection
Switches and wires	<ol style="list-style-type: none"> 1、 Broken main cable 2、 Broken main switch

TROUBLESHOOTING

Starter motor	<ol style="list-style-type: none"> 1、 Faulty starter motor 2、 Faulty starter relay 3、 Faulty overrunning clutch in engine 4、 Broken main switch 5、 Broken main fuse
Battery	<ol style="list-style-type: none"> 1、 Low battery voltage 2、 Faulty battery
COMPRESSION SYSTEM	
Cylinder and cylinder head	<ol style="list-style-type: none"> 1、 Loose spark plug 2、 Loose cylinder head or cylinder 3、 Broken cylinder head gasket 4、 Broken cylinder gasket 5、 Worn, damaged or seized cylinder
Piston and piston rings	<ol style="list-style-type: none"> 1、 Improperly installed piston ring 2、 Worn, fatigued or broken piston ring 3、 Seized piston ring 4、 Seized or damaged piston
Valve, camshaft and crankshaft	<ol style="list-style-type: none"> 1、 Improperly sealed valve 2、 Improperly contacted valve and valve seat 3、 Improper valve timing 4、 Broken valve spring 5、 Seized camshaft
Crankcase and crankshaft	<ol style="list-style-type: none"> 1、 Improperly seated crankcase 2、 Seized crankshaft
Valve train	<ol style="list-style-type: none"> 1、 Improperly adjusted valve clearance 2、 Improperly adjusted valve timing

POOR IDLE SPEED PERFORMANCE

POOR IDLE SPEED PERFORMANCE	
EFI system	<ol style="list-style-type: none"> 1、 Broken ECU 2、 Clogged nozzle or the rupture the line from nozzle to ECU 3、 Damage of engine speed signal sensor 4、 Rupture of the line from engine speed signal sensor to ECU 5、 Broken inlet pressure or temperature sensor or damaged line to ECU 6、 Broken air throttle or damage line to ECU. 7、 Broken vice line (cable) of electrical injection

TROUBLESHOOTING

Electrical system	<ol style="list-style-type: none"> 1、 Faulty ignition plug 2、 The performance of speed sensor become poor 3、 Faulty ignition coil
Valve train	Improperly adjusted valve clearance
Air filter	Clogged air filter element

POOR MEDIUM AND HIGH-SPEED PERFORMANCE

POOR MEDIUM AND HIGH-SPEED PERFORMANCE	
EFI system	<ol style="list-style-type: none"> 1、 Broken ECU 2、 The performance of speed signal sensor become poor 3、 The main nozzle clog or loose 4、 Spoiled or pollute oil 5、 Broken inlet pressure / temperature sensor 6、 Air throttle position sensor loose
Air filter	Clogged air filter element
Muffler	Clogged muffler
Set out	The reverse signal error trigger

FAULTY GEAR SHIFTING

SHIFT LEVER DOES NOT MOVE	
Shift drum, shift forks	<ol style="list-style-type: none"> 1、 Groove jammed with impurities 2、 Seized shift fork 3、 Bent shift fork guide bar 4、 Broken shift guide
Transmission	<ol style="list-style-type: none"> 1、 Seized transmission gear 2、 Incorrectly assembled transmission
Shift guide	<ol style="list-style-type: none"> 1、 Broken shift guide mechanism 2、 Broken shift flexible shaft
JUMPS OUT OF GEAR	
Shift forks	Worn shift fork
Shift drum	<ol style="list-style-type: none"> 1、 Improper thrust play 2、 Worn shift drum groove
Transmission	Worn gear dog

TROUBLESHOOTING

ENGINE OVERHEATING

OVERHEATING	
Ignition system	1、 Improper spark plug gap 2、 Improper spark plug heat range
Fuel system	1、 Improper fuel level 2、 Clogged air filter element
Compression system	Heavy carbon deposit
Engine oil	1、 Improper oil level 2、 Improper oil viscosity 3、 Inferior oil quality
Brake	Brake drag
Cooling system	1、 Low coolant level 2、 Clogged or damaged radiator 3、 Damaged or faulty water pump 4、 Faulty fan motor 5、 Faulty thermo switch
Oil cooling system	Clogged or damaged oil cooler

FAULTY BRAKE

POOR BRAKING EFFECT	
Disc brake	1、 Worn brake pads 2、 Worn disc 3、 Air in brake fluid 4、 Leaking brake fluid 5、 Faulty master cylinder kit cup 6、 Faulty caliper kit sea 7、 Loose union bolt 8、 Broken brake hose and pipe 9、 Oily or greasy disc/brake pads 10、 Improper brake fluid level

TROUBLESHOOTING

SHOCK ABSORBER MALFUNCTION

Loss of damping function	
Shock absorber	<ol style="list-style-type: none"> 1、 Bent or damaged damper rod 2、 Damaged oil seal lip 3、 Fatigued shock absorber spring

UNSTABLE HANDLING

UNSTABLE HANDLING	
Steering column	Improperly installed or bent
Steering	<ol style="list-style-type: none"> 1、 Incorrect toe-in 2、 Bent steering shaft 3、 Improperly installed steering shaft 4、 Damaged bearing 5、 Bent tie-rods
Tires	<ol style="list-style-type: none"> 1、 Uneven tire pressures on both sides 2、 Incorrect tire pressure 3、 Uneven tire wear
Rim	<ol style="list-style-type: none"> 1、 Deformed wheel 2、 Loose bearing 3、 Bent or loose wheel axle
Frame	<ol style="list-style-type: none"> 1、 Bent 2、 Damaged frame
Suspension	<ol style="list-style-type: none"> 1、 Over worn or loosen main knuckle ball stud 2、 Bent rocker 3、 Broken shock absorber 4、 Broken buffer rubber of rocker shaft

LIGHTING SYSTEM

HEAD LIGHT IS OUT OF WORK	
Head light is out of work	<ol style="list-style-type: none"> 1、 Improper bulb 2、 Too many electric accessories 3、 Hard charging(broken stator coil and/or faulty rectifier/regulator) 4、 Incorrect connection 5、 Improperly grounded 6、 Bulb life expired

TROUBLESHOOTING

BULB BURNT OUT	
Bulb burnt out	<ol style="list-style-type: none">1、 Improper bulb2、 Faulty battery3、 Faulty rectifier/regulator4、 Improperly grounded5、 Faulty main and/or lights switch6、 Bulb life expired
ERROR DISPLAY OF METER	
Wrong Speed	<ol style="list-style-type: none">1、 Then sensor on rear axle is damaged or polluted by iron powder2、 The connection between sensor to meter is wrong.3、 Broken meter

WIRING DIAGRAM

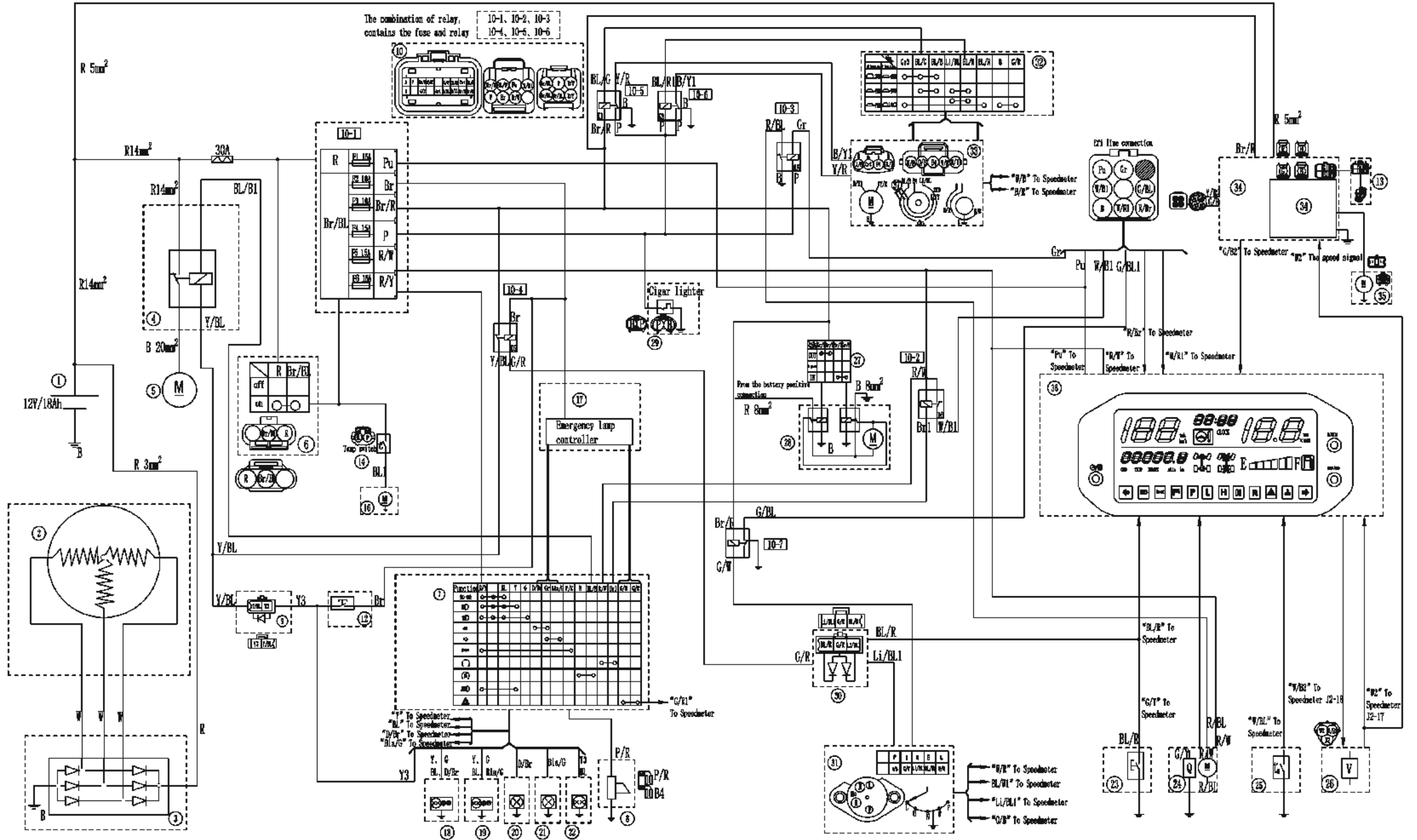

- | | | | | | |
|--------------------------|--|------------------------------------|--------------------------------------|---------------------------------|-------------------------------|
| 1. Battery parts | 9. Brake start diode | 10-7. Reverse gear relay | 18. Head light Assy. (L) | 26. Speed sensor parts | 34. Power steering controller |
| 2. Magneto exciter | 10. Delay Assy. | 11. The auto relay Assy. | 19. Head light Assy. (R) | 27. Windlass controller switch | 35. Power steering motor |
| 3. Inverter/regulator | 10-1. Fuse | 12. Brake switch | 20. Rear turn signal light Assy. (L) | 28. Windlass relay Assy. | 36. Speedometer part |
| 4. Starter relay | 10-2. Ignition relay | 13. Throttle sensor | 21. Rear turn signal light Assy. (R) | 29. DC socket Assy. | 37. Differential solenoid |
| 5. Starter motor | 10-3. Oil pump relay | 14. Fan temperature control switch | 22. Rear brake light Assy. | 30. 4 gear, parking start diode | |
| 6. Ignition switch parts | 10-4. 4 gear, parking ignition relay | 15. Fan controller | 23. Left hand switch | 31. Document show Assy. | |
| 7. Horn part switch | 10-5. Front axle 3/4HP control relay | 16. Fan motor | 24. Fuel pump parts | 32. Drive switch Assy. | |
| 8. Horn parts | 10-6. Front axle differential lock control relay | 17. Emergency lamp controller | 25. Water temperature sensor | 33. Front axle transfer | |

Note:
 R-Red Pu-Purple Li-Light W-White D-Dark Bla-Blackish
 Br-Brown Y-Yellow BL-Blue B-Black Gr-Grey P-Pink
 O-Orange G-Green

WIRING ECU DIAGRAM

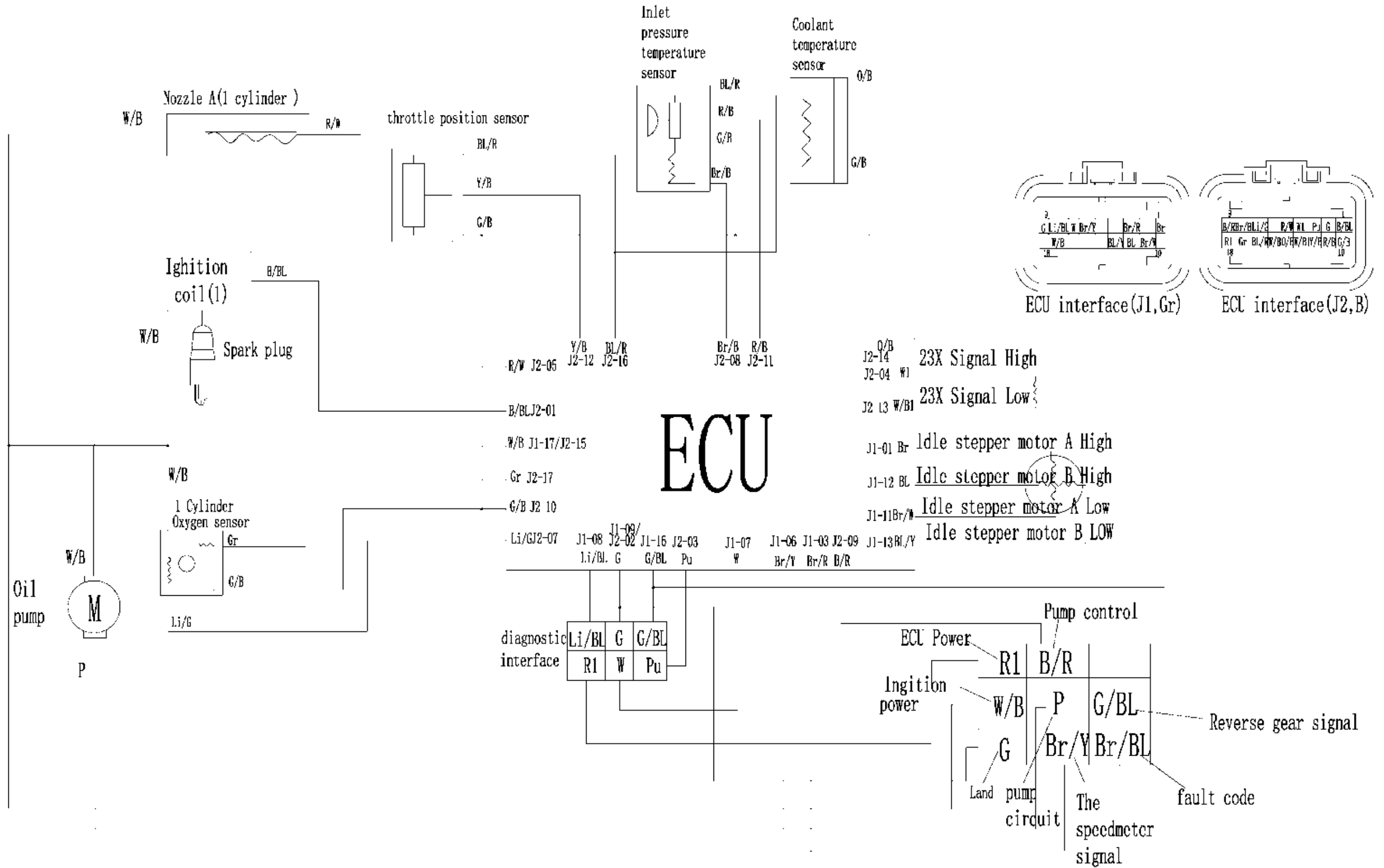

IGNITION SYSTEM CIRCUIT DIAGRAM

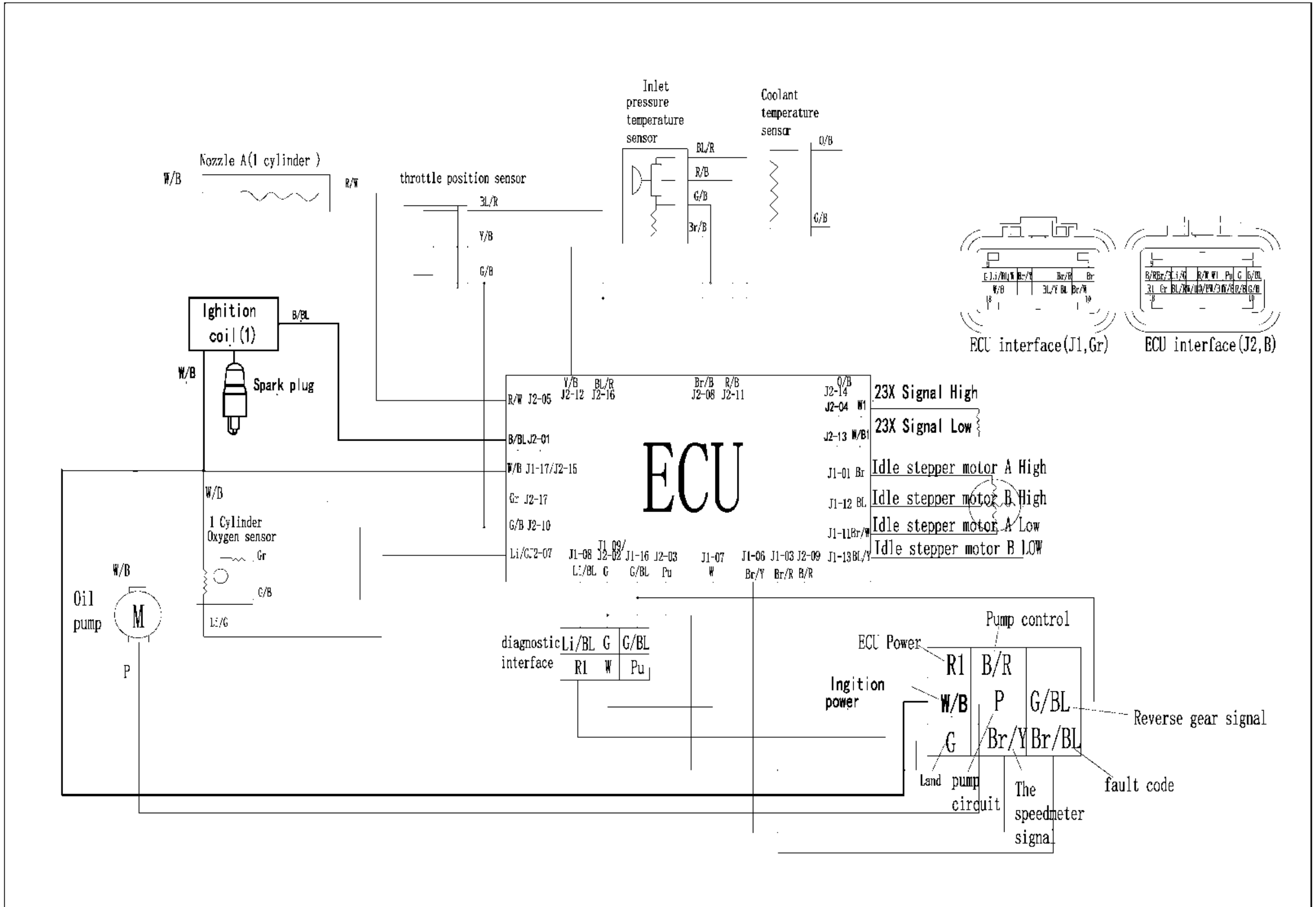

CHARGING SYSTEM CIRCUIT DIAGRAM

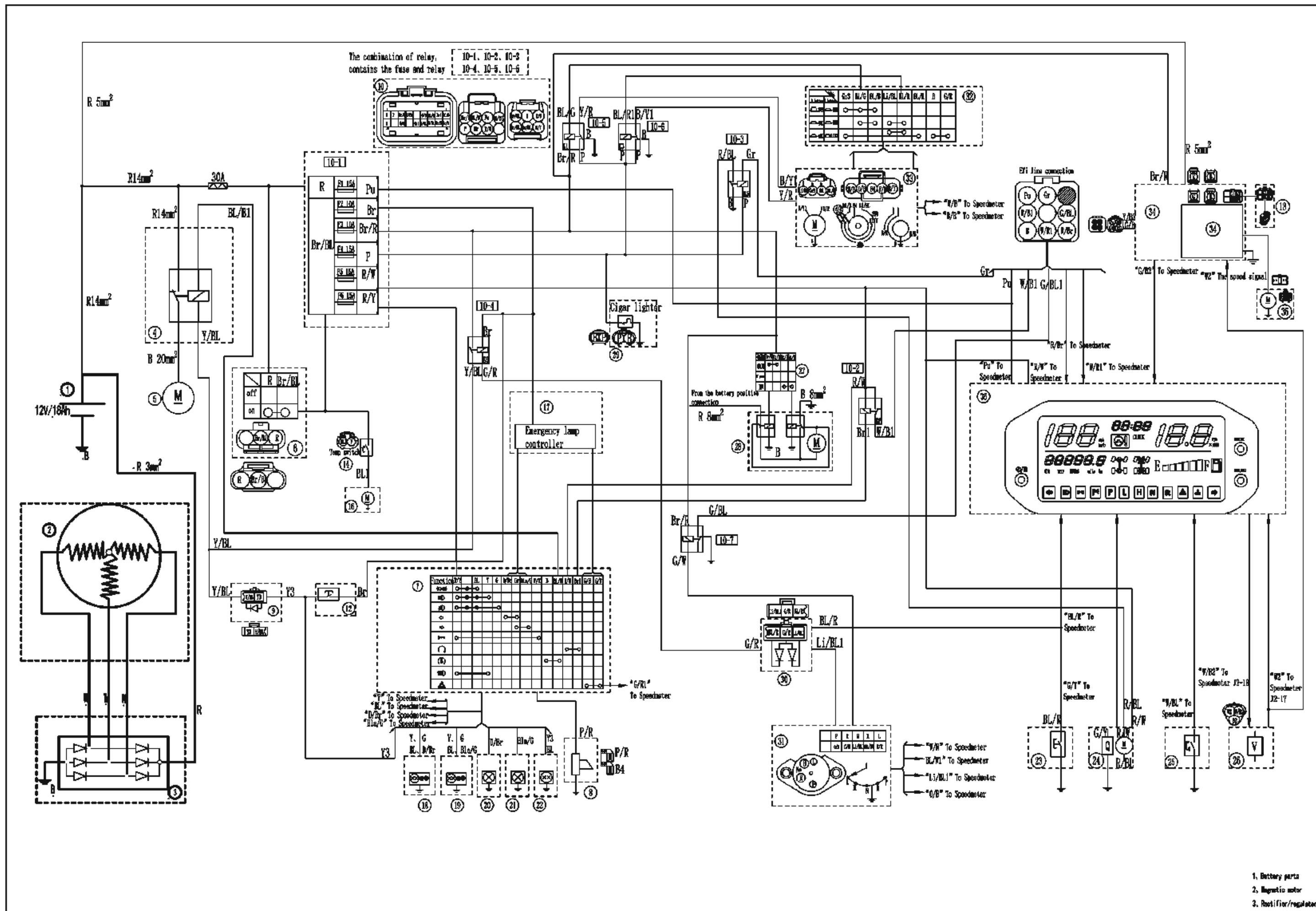

ELECTRIC STARTING SYSTEM CIRCUIT DIAGRAM

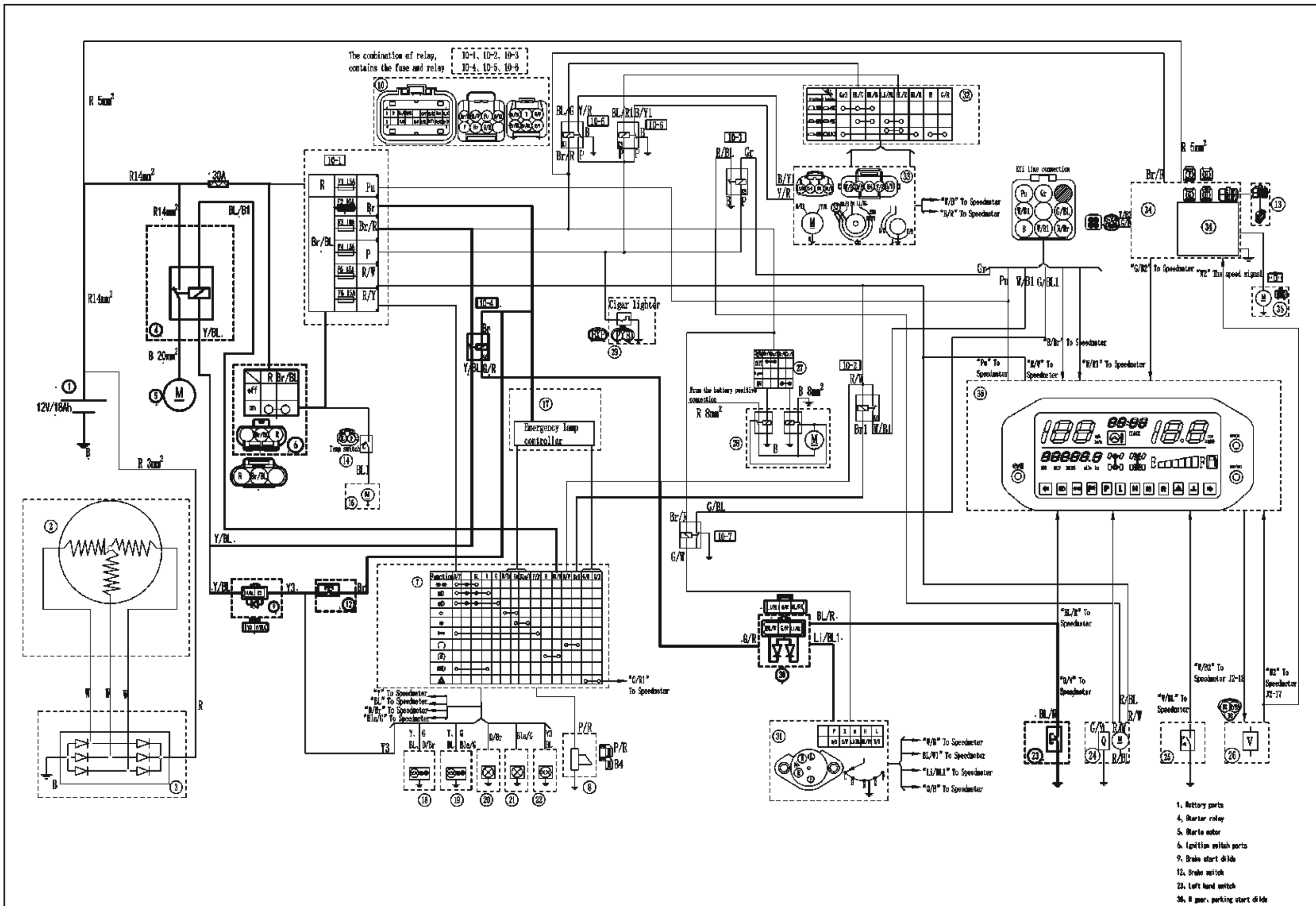

LIGHTING SYSTEM CIRCUIT DIAGRAM

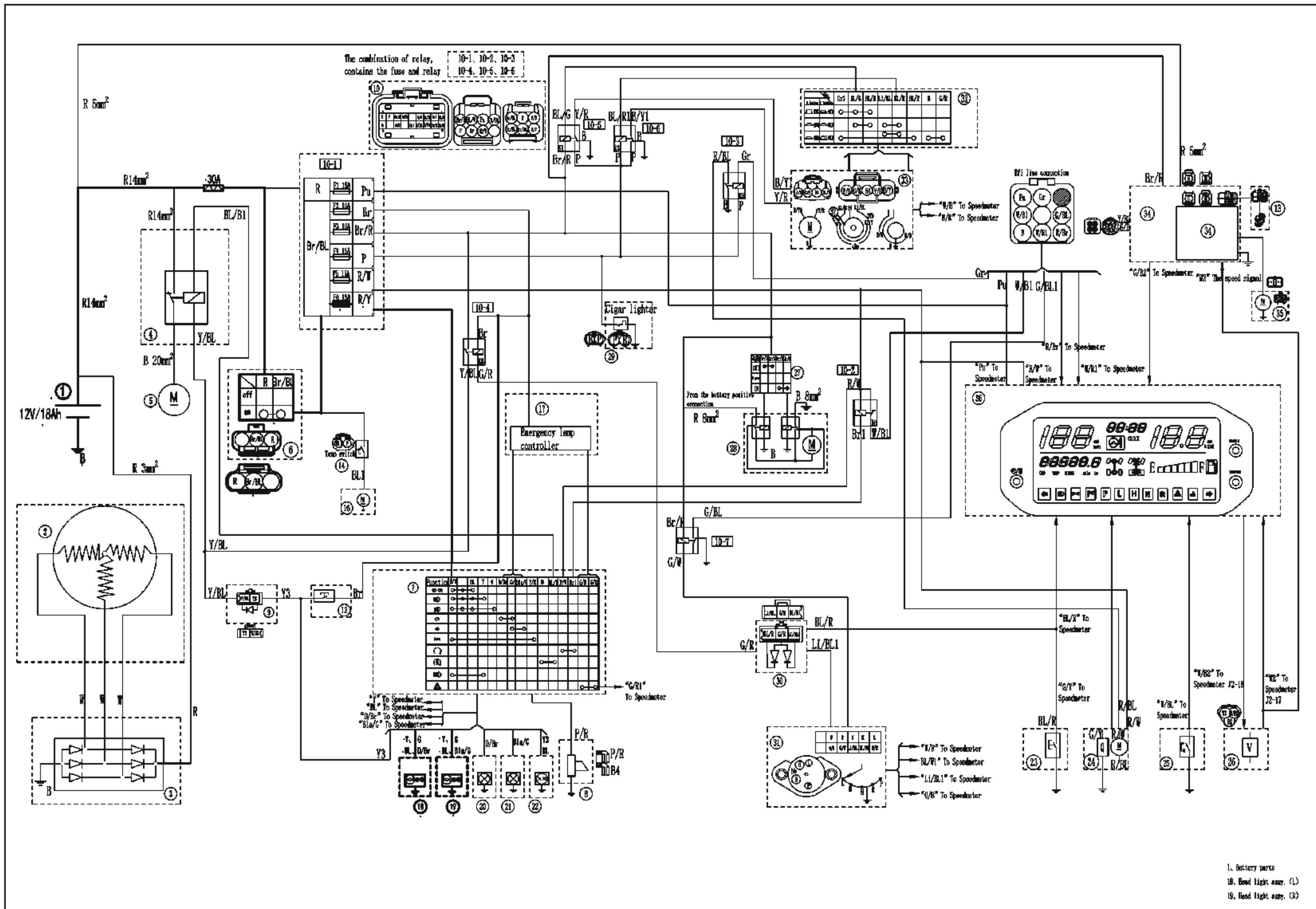

SIGNALING SYSTEM CIRCUIT DIAGRAM

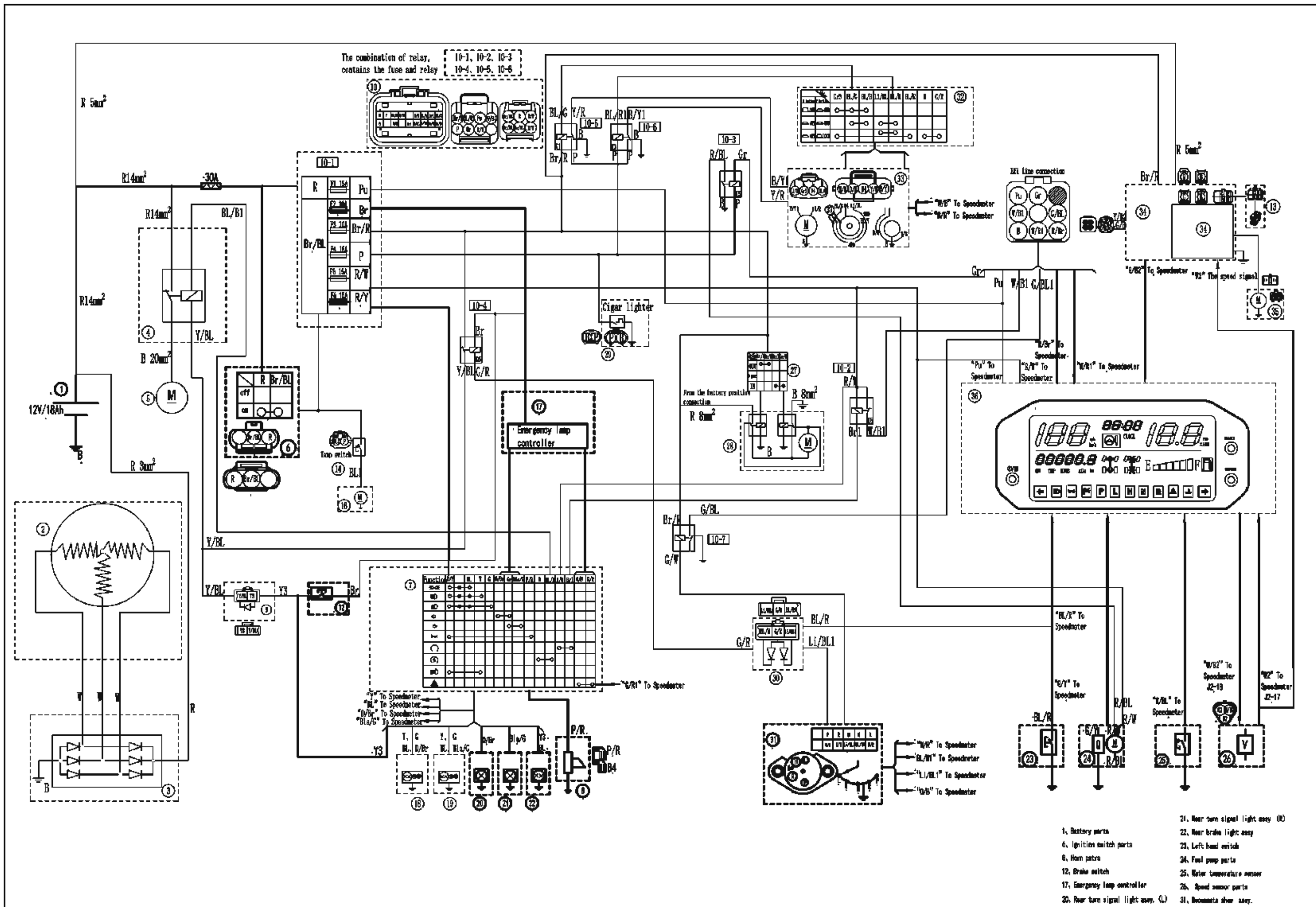

COOLING SYSTEM CIRCUIT DIAGRAM

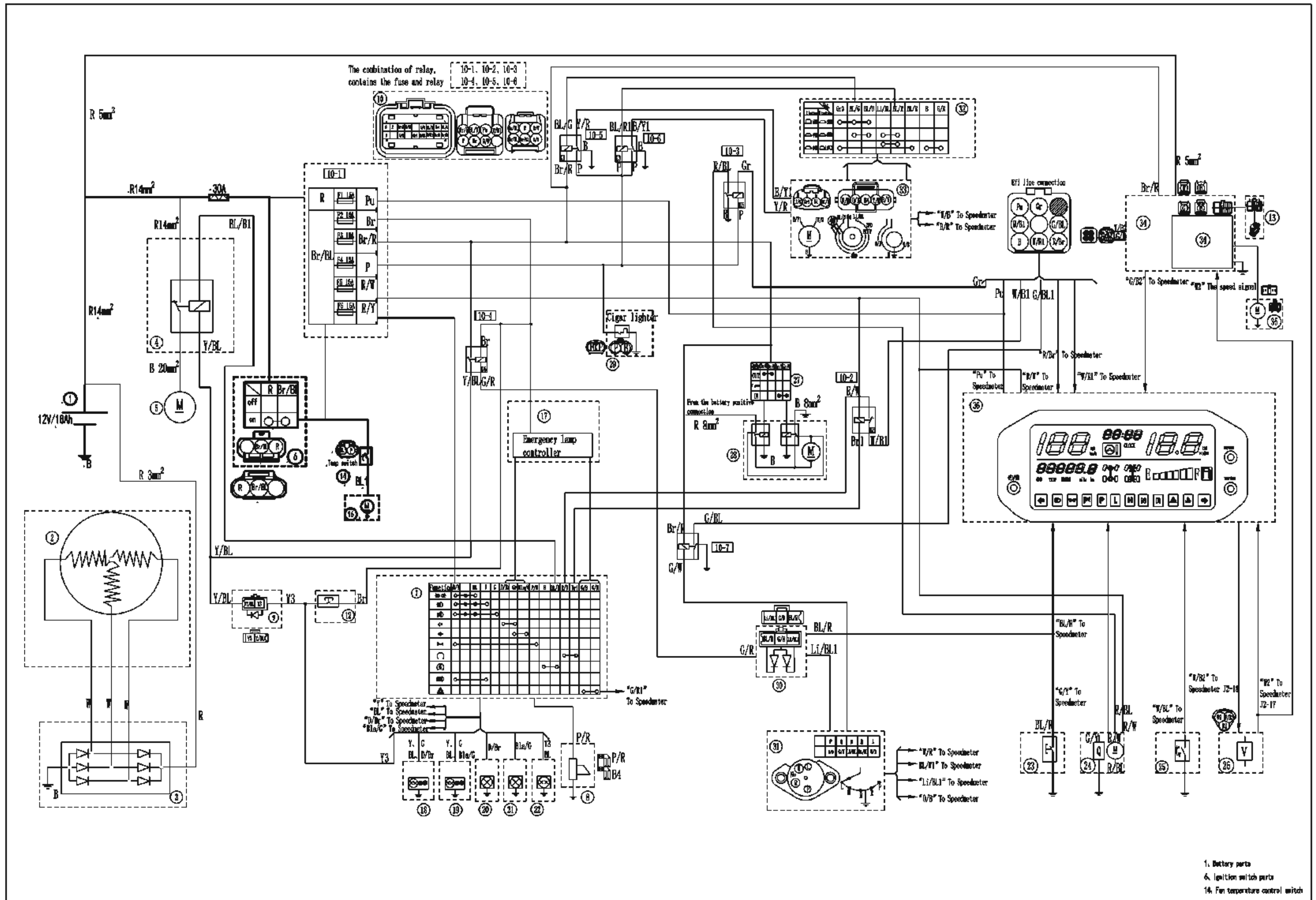

2WD/4WD SELECTING SYSTEM CIRCUIT DIAGRAM

