

KYMCO SERVICE MANUAL

MXU 150

MX'er 150/125

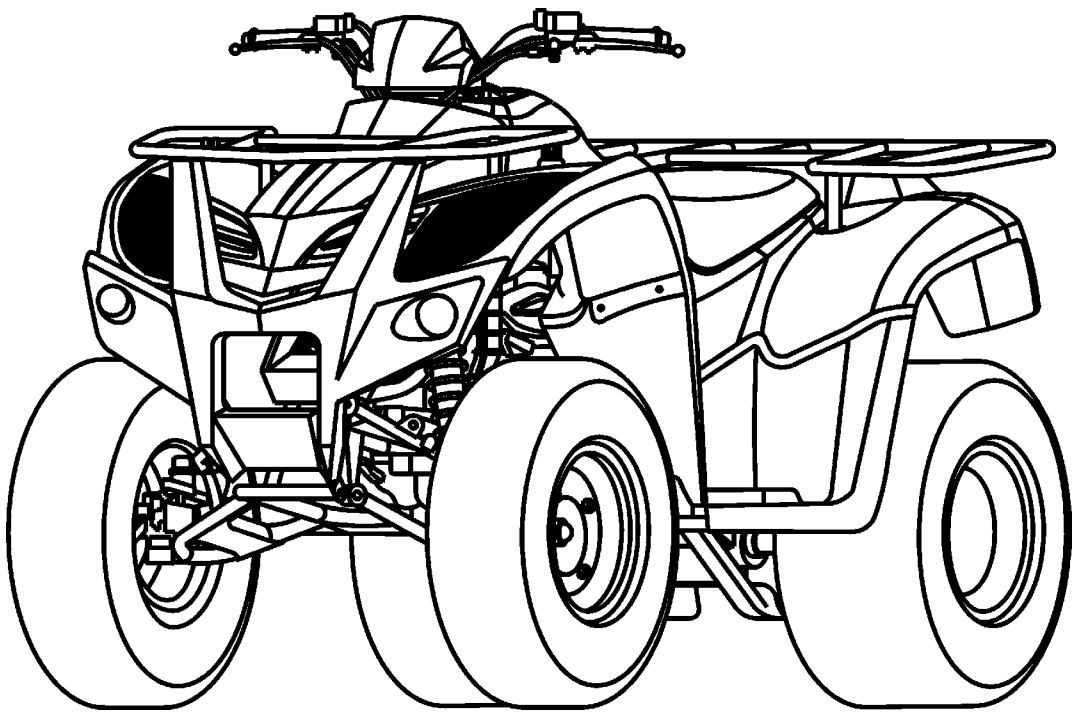

Issued: 08.06.2005

**By KWANG YANG Motor Co., Ltd.
First Edition, Jun 2005
All rights reserved. Any reproduction or
unauthorized use without the written permission of
KWANG YANG Motor Co., Ltd.
is expressly prohibited.
4122-LCA4/LLB1-S00**

PREFACE

This Service Manual describes the technical features and servicing procedures for the KYMCO *ATV 150/125*.

Section 1 contains the precautions for all operations stated in this manual. Read them carefully before starting any operation.

Section 2 is the removal/installation procedures for the frame covers which are subject to higher removal/installation frequency during maintenance and servicing operations.

Section 3 describes the inspection/adjustment procedures, safety rules and service information for each part, starting from periodic maintenance.

Sections 4 through 18 give instructions for disassembly, assembly and inspection of engine, chassis frame and electrical equipment.

Most sections start with an assembly or system illustration and troubleshooting for the section. The subsequent pages give detailed procedures for the section.

The information and contents included in this manual may be different from the ATV in case specifications are changed. KYMCO reserves the right to make changes at any time without notice and without incurring any obligation.

KWANG YANG MOTOR CO., LTD.
OVERSEAS SALES DEPARTMENT
OVERSEAS SERVICE SECTION

TABLE OF CONTENTS

	GENERAL INFORMATION	1
	FRAME COVERS/EXHAUST MUFFLER	2
	INSPECTION/ADJUSTMENT	3
	LUBRICATION SYSTEM	4
	FUEL SYSTEM	5
ENGINE	ENGINE REMOVAL/INSTALLATION	6
	CYLINDER HEAD/VALVES	7
	CYLINDER/PISTON	8
	DRIVE AND DRIVEN PULLEYS	9
	FINAL REDUCTION/TRANSMISSION SYSTEM	10
	CRANKCASE/CRANKSHAFT/BALANCE SHAFT	11
CHASSIS	FRONT WHEEL/FRONT BRAKE/FRONT SUSPENSION/STEERING SYSTEM	12
	REAR WHEEL /SWING ARM/HYDRAULIC BRAKE	13
ELECTRICAL EQUIPMENT	BATTERY/CHARGING SYSTEM/A.C. GENERATOR	14
	IGNITION SYSTEM	15
	STARTING SYSTEM	16
	LIGHTS/SWITCHES	17
	ONLY ATV ON ROAD AVAILABLE	18

1. GENERAL INFORMATION

GENERAL INFORMATION

SERIAL NUMBER	1- 1
SPECIFICATIONS	1- 2
SERVICE PRECAUTIONS	1- 5
TORQUE VALUES	1-13
SPECIAL TOOLS	1-15
LUBRICATION POINTS	1-16
CABLE & HARNESS ROUTING (MX'er 150/125)	1-19
CABLE & HARNESS ROUTING (MXU 150)	1-23
WIRING DIAGRAM	1-28
TROUBLESHOOTING	1-32

1. GENERAL INFORMATION

SERIAL NUMBER

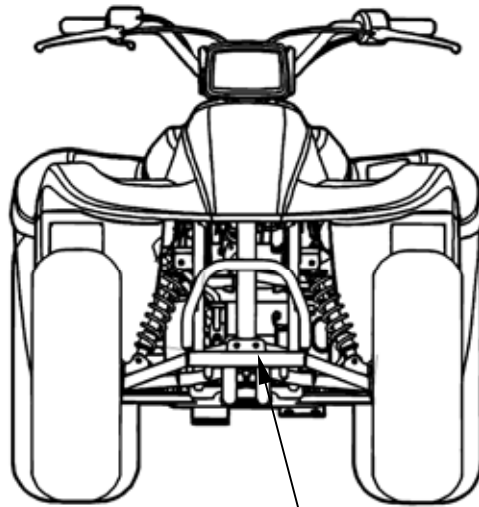

Location of Frame Serial Number

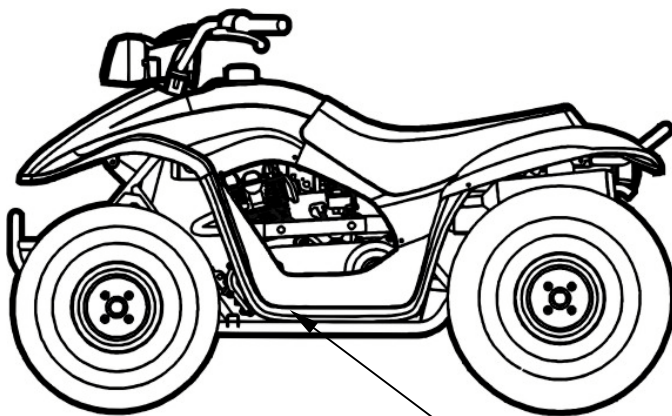

Location of Engine Serial Number

1. GENERAL INFORMATION

SPECIFICATIONS (MX'er 150)

Model No.		LA30		
ATV Name		MX'er 150		
Overall length		1600 mm (64 in)		
Overall width		980 mm (39.2 in)		
Overall height		990 mm (39.6 in)		
Wheel base		1120 mm (44.8 in)		
Engine type		O.H.C.		
Displacement		149.4 cc (9.1 cu-in)		
Fuel Used		92# nonleaded gasoline		
Dry weight	Front wheel	74 kg (162.8 lbs)		
	Rear wheel	78 kg (171.6 lbs)		
	Total	152 kg (334.4 lbs)		
Gross weight	Front wheel	80 kg (176 lbs)		
	Rear wheel	82 kg (180.4 lbs)		
	Total	162 kg (356.4 lbs)		
Tires	Front wheel	20*7-8		
	Rear wheel	22*10-8		
Ground clearance		130 mm (5.2 in)		
Performance	Breaking distance (m)(ANSI)	20.6 below		
	Min. turning radius (m)	3		
Engine	Starting system		Starting motor	
	Type		Gasoline, 4-stroke	
	Cylinder arrangement		Single cylinder	
	Combustion chamber type		Semi-sphere	
	Valve arrangement		O.H.C., chain drive	
	Bore x stroke		62 x 49.5 mm (2.48 x 1.98 in)	
	Compression ratio		9.7:1	
	Compression pressure (kg/cm ²)		1600 kPa (16 kg/cm ² , 227.2 psi)	
	Intake	Open	5.5° BTDC	
		Close	27.5° ABDC	
	Exhaust	Open	36° BBDC	
		Close	4° ATDC	
	Valve clearance	Intake	0.06 mm (0.0024 in)	
		Exhaust	0.06 mm (0.0024 in)	
	Idle speed		1700 rpm	
	Lubrication System	Lubrication type		Forced pressure & wet sump
		Oil pump type		Inner/outer rotor type
		Oil filter type		Full-flow filtration
		Oil capacity		1 liter (0.88 Imp qt, 1.06 US qt)
		Oil exchanging capacity		0.9 liter (0.79 Imp qt, 0.95 US qt)
	Cooling Type		Air cooling	
	Fuel System	Air cleaner type & No		Sponge
		Fuel capacity		8.1 liters (1.7 Imp gal, 2.11 USgal)
Carburetor		Type		PD
		Float lever		14.8 mm (0.592 in)
	Venturi dia.		φ25 mm (φ1 in)	
	Throttle type		PISTON	
Electrical Equipment	Ignition System	Type		CDI
		Ignition timing		15°BTDC/1700rpm
		Contact breaker		Non-contact point type
		Spark plug (NGK)		CR8E
	Spark plug gap		0.6~0.7 mm (0.024~0.028 in)	
Battery	Capacity		12V8AH	
Power Drive System	Clutch type		CVT	
	Primary reduction system		Helical gear/spur gear	
	Secondary reduction system		Chain drive	
	Primary reduction ratio		2.8-0.95	
	Secondary reduction ratio		7.226	
	Reverse ratio		26.902	
Moving Device	FR/RR tire rolling circumference		1596/1756 mm (63.84/70.24 in)	
	Tire pressure	Front	20 kPa (0.2 kg/cm ² , 2.84 psi)	
		Rear	25 kPa (0.25 kg/cm ² , 3.55 psi)	
	Turning angle	Left	44°	
Right		44°		
Brake system type		Rear	Disk brake Drum brake	
		Front	Drum brake	
Damping Device	Suspension type	Front	Swing	
		Rear	Swing arm	
	Shock type	Front	Swing	
		Rear	Swing arm	
Frame type		Steel tube type		

1. GENERAL INFORMATION

(MX'er 125)

Model No.		LA25		
ATV Name		MX'er 125		
Overall length		1685 mm (67.4 in)		
Overall width		980 mm (39.2 in)		
Overall height		990 mm (39.6 in)		
Wheel base		1120 mm (44.8 in)		
Engine type		O.H.C.		
Displacement		124 cc (7.55 cu-in)		
Fuel Used		92# nonleaded gasoline		
Dry weight	Front wheel	74 kg (162.8 lbs)		
	Rear wheel	78 kg (171.6 lbs)		
	Total	152 kg (334.4 lbs)		
Gross weight	Front wheel	80 kg (176 lbs)		
	Rear wheel	82 kg (180.4 lbs)		
	Total	162 kg (356.4 lbs)		
Tires	Front wheel	20*7-8		
	Rear wheel	22*10-8		
Ground clearance		130 mm (5.2 in)		
Performance	Breaking distance (m)(ANSI)	20.6 below		
	Min. turning radius (m)	2.5		
Engine	Starting system		Starting motor	
	Type		Gasoline, 4-stroke	
	Cylinder arrangement		Single cylinder	
	Combustion chamber type		Semi-sphere	
	Valve arrangement		O.H.C., chain drive	
	Bore x stroke		56.5 x 49.5 mm (2.26 x 1.98 in)	
	Compression ratio		9.2:1	
	Compression pressure (kg/cm ²)		1400 kPa (14 kg/cm ² , 198.8 psi)	
	Intake	Open	5.5° BTDC	
		Close	27.5° ABDC	
	Exhaust	Open	36° BBDC	
		Close	4° ATDC	
	Valve clearance	Intake	0.06 mm (0.0024 in)	
		Exhaust	0.06 mm (0.0024 in)	
	Idle speed		1700 rpm	
	Lubrication System	Lubrication type		Forced pressure & wet sump
		Oil pump type		Inner/outer rotor type
		Oil filter type		Full-flow filtration
		Oil capacity		1 liter (0.88 Imp qt, 1.06 US qt)
		Oil exchanging capacity		0.9 liter (0.79 Imp qt, 0.95 US qt)
	Cooling Type		Air cooling	
Fuel System	Air cleaner type & No		Sponge	
	Fuel capacity		8.1 liters (1.7 Imp gal, 2.11 Usgal)	
	Carburetor	Type	PD	
		Float lever	14.8 mm (0.592 in)	
Venturi dia.		φ25 mm (φ1 in)		
Throttle type		PISTON		
Electrical Equipment	Ignition System	Type	CDI	
		Ignition timing	15° BTDC/1700rpm	
		Contact breaker	Non-contact point type	
		Spark plug (NGK)	CR8E	
	Spark plug gap	0.6~0.7 mm (0.024~0.028 in)		
	Battery	Capacity	12V8AH	
Power Drive System	Clutch type		CVT	
	Primary reduction system		Helical gear/spur gear	
	Secondary reduction system		Chain drive	
	Primary reduction ratio		2.8-0.95	
	Secondary reduction ratio		7.226	
	Reverse ratio		26.902	
Moving Device	FR/RR tire rolling circumference		1596/1756 mm (63.84/70.24 in)	
	Tire pressure	Front	20 kPa (0.2 kg/cm ² , 2.84 psi)	
		Rear	25 kPa (0.25 kg/cm ² , 3.55 psi)	
	Turning angle	Left	44°	
Right		44°		
Brake system type	Rear	Disk brake	Drum brake	
	Front	Drum brake		
Damping Device	Suspension type	Front	Swing	
		Rear	Swing arm	
	Shock type	Front	Swing	
		Rear	Swing arm	
Frame type		Steel tube type		

1. GENERAL INFORMATION

(MXU 150)

Model No.		LA30		
ATV Name		MXU 150		
Overall length		1775 mm (71 in)		
Overall width		950 mm (38 in)		
Overall height		1040 mm (41.6 in)		
Wheel base		1115 mm (44.6 in)		
Engine type		OHC		
Displacement		149 cc (9.1 cu-in)		
Fuel Used		92# nonleaded gasoline		
Dry weight	Front wheel	87 kg (191.4 lbs)		
	Rear wheel	88 kg (193.6 lbs)		
	Total	175 kg (385 lbs)		
Gross weight	Front wheel	92 kg (202.4 lbs)		
	Rear wheel	93 kg (204.6 lbs)		
	Total	185 kg (407 lbs)		
Tires	Front wheel	21*7-10		
	Rear wheel	22*10-10		
Ground clearance		155 mm (6.2 in)		
Performance	Breaking distance (m)(ANSI)	20.6 below		
	Min. turning radius (m)	3		
Engine	Starting system		Starting motor	
	Type		Gasoline, 4-stroke	
	Cylinder arrangement		Single cylinder	
	Combustion chamber type		Semi-sphere	
	Valve arrangement		O.H.C., chain drive	
	Bore x stroke		62 x 49.5 (2.48 x 1.98 in)	
	Compression ratio		9.7:1	
	Compression pressure		1600 kPa (16 kg/cm ² , 227.2 psi)	
	Intake	Open	5.5° BTDC	
		Close	27.5° ABDC	
	Exhaust	Open	36° BBDC	
		Close	4° ATDC	
	Valve clearance	Intake	0.06 mm (0.0024 in)	
		Exhaust	0.06 mm (0.0024 in)	
	Idle speed		1700 rpm	
	Lubrication System	Lubrication type		Forced pressure & Wet sump
		Oil pump type		Inner/outer rotor type
		Oil filter type		Full-flow filtration
		Oil capacity		1 liter (0.88 Imp qt, 1.06 US qt)
		Oil exchanging capacity		0.9 liter (0.79 Imp qt, 0.95 US qt)
Cooling Type		Air cooling		

Fuel System	Air cleaner type & No		Sponge	
	Fuel capacity		8.1 liters (1.7 Imp gal, 2.11 Usgal)	
	Carburetor	Type		PD
		Piston dia.		14.8 mm (0.592 in)
Venturi dia.(mm)		φ25 mm (φ1 in)		
Throttle type		PISTON		
Electrical Equipment	Ignition System	Type		CDI
		Ignition timing		15°BTDC/1700rpm
		Contact breaker		Non-contact point type
		Spark plug (NGK)		CR8E
	Spark plug gap		0.6~0.7 mm (0.024~0.028 in)	
Battery		Capacity	12V8AH	
Power Drive System	Clutch type		CVT	
	Primary reduction system		Helical gear/spur gear	
	Secondary reduction system		Chain drive	
	Primary reduction ratio		2.8-0.95	
	Secondary reduction ratio		7.226	
	Reverse ratio		26.902	
Moving Device	FR/RR tire rolling circumference		1675/1756 mm (67/70.24 in)	
	Tire pressure	Front	28 Kpa (0.28 kg/cm ² , 3.976 psi)	
		Rear	28 Kpa (0.28 kg/cm ² , 3.976 psi)	
	Turning angle	Left	40°	
Right		40°		
Brake system type	Rear	Disk brake	Drum brake	
	Front	Drum brake		
Damping Device	Suspension type	Front	Swing	
		Rear	Swing arm	
	Shock type	Front	Swing	
		Rear	Swing arm	
Frame type		Steel tube pipe		

1. GENERAL INFORMATION

SERVICE PRECAUTIONS

- Make sure to install new gaskets, O-rings, circlips, cotter pins, etc. when reassembling.

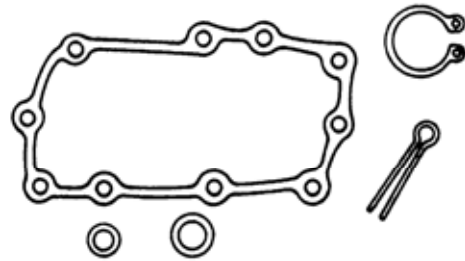

- When tightening bolts or nuts, begin with larger-diameter to smaller ones at several times, and tighten to the specified torque diagonally.

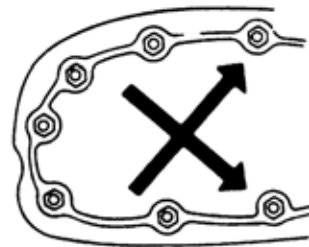

- Use genuine parts and lubricants.

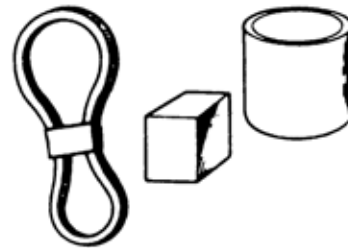

- When servicing the motorcycle, be sure to use special tools for removal and installation.



- After disassembly, clean removed parts. Lubricate sliding surfaces with engine oil before reassembly.



1. GENERAL INFORMATION

- Apply or add designated greases and lubricants to the specified lubrication points.

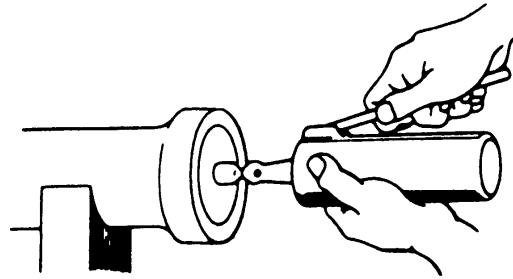

- After reassembly, check all parts for proper tightening and operation.

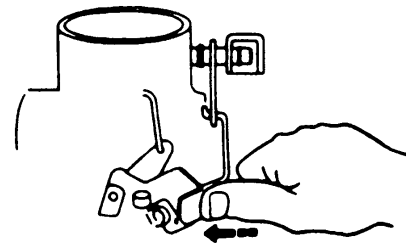

- When two persons work together, pay attention to the mutual working safety.

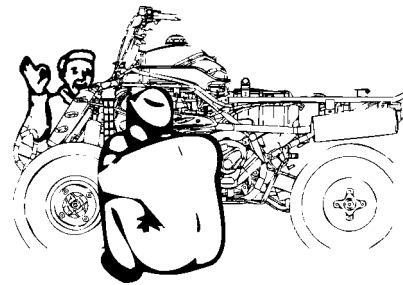

- Disconnect the battery negative (-) terminal before operation.
- When using a spanner or other tools, make sure not to damage the motorcycle surface.

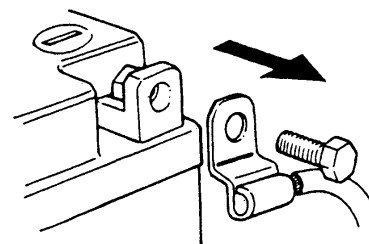

- After operation, check all connecting points, fasteners, and lines for proper connection and installation.
- When connecting the battery, the positive (+) terminal must be connected first.
- After connection, apply grease to the battery terminals.
- Terminal caps shall be installed securely.

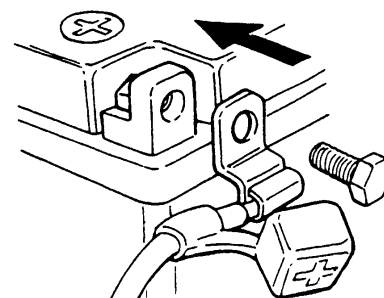

1. GENERAL INFORMATION

- If the fuse is burned out, find the cause and repair it. Replace it with a new one according to the specified capacity.

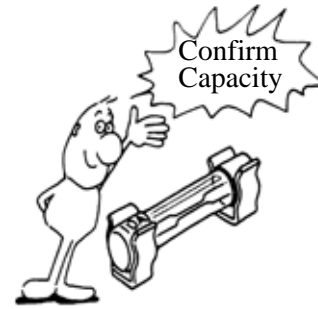

- After operation, terminal caps shall be installed securely.



- When taking out the connector, the lock on the connector shall be released before operation.

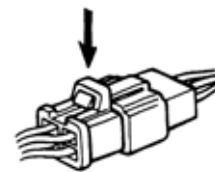

- Hold the connector body when connecting or disconnecting it.
- Do not pull the connector wire.



- Check if any connector terminal is bending, protruding or loose.

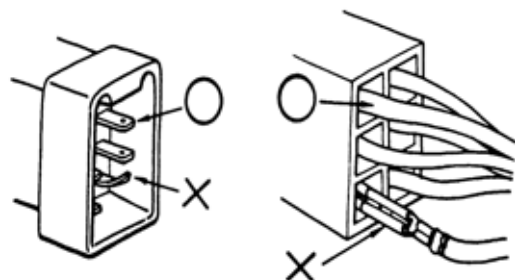

1. GENERAL INFORMATION

- The connector shall be inserted completely.
- If the double connector has a lock, lock it at the correct position.
- Check if there is any loose wire.

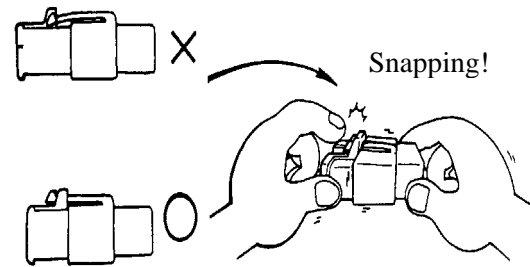

- Before connecting a terminal, check for damaged terminal cover or loose negative terminal.

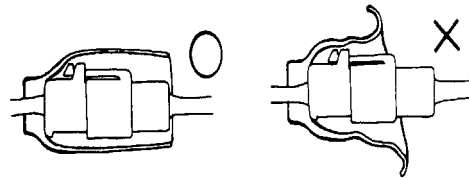

- Check the double connector cover for proper coverage and installation.

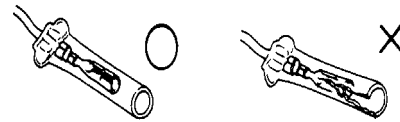

- Insert the terminal completely.
- Check the terminal cover for proper coverage.
- Do not make the terminal cover opening face up.

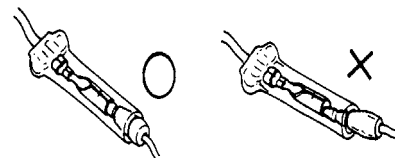

- Secure wire harnesses to the frame with their respective wire bands at the designated locations. Tighten the bands so that only the insulated surfaces contact the wire harnesses.

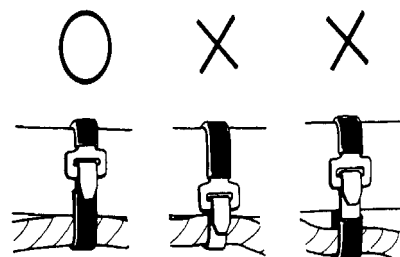

1. GENERAL INFORMATION

- After clamping, check each wire to make sure it is secure.

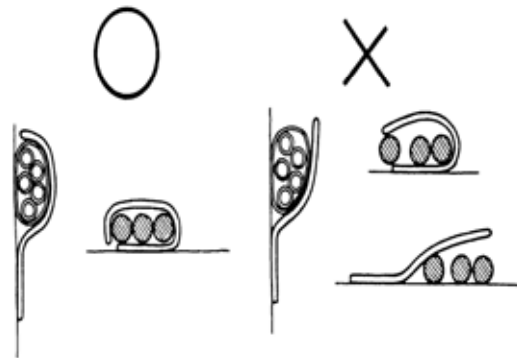

- Do not squeeze wires against the weld or its clamp.



- After clamping, check each harness to make sure that it is not interfering with any moving or sliding parts.

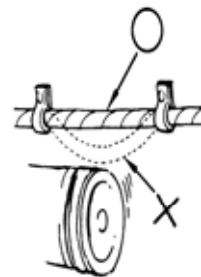

- When fixing the wire harnesses, do not make it contact the parts which will generate high heat.

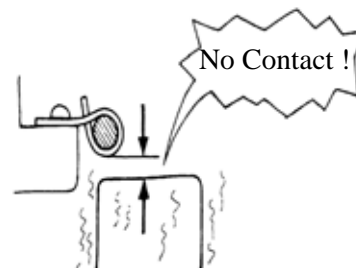

- Route wire harnesses to avoid sharp edges or corners. Avoid the projected ends of bolts and screws.
- Route wire harnesses passing through the side of bolts and screws. Avoid the projected ends of bolts and screws.

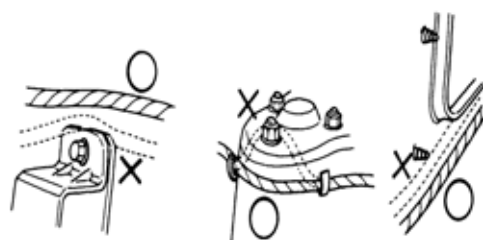

1. GENERAL INFORMATION

- Route harnesses so they are neither pulled tight nor have excessive slack.

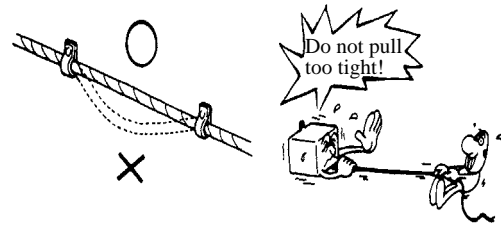

- Protect wires and harnesses with electrical tape or tube if they contact a sharp edge or corner.

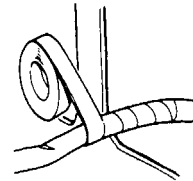

- When rubber protecting cover is used to protect the wire harnesses, it shall be installed securely.

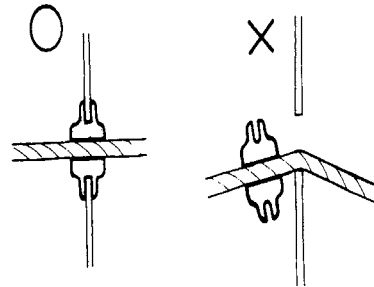

- Do not break the sheath of wire.
- If a wire or harness is with a broken sheath, repair by wrapping it with protective tape or replace it.

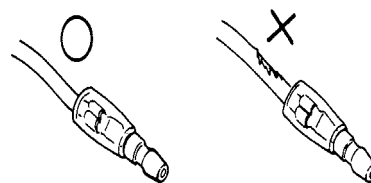

- When installing other parts, do not press or squeeze the wires.

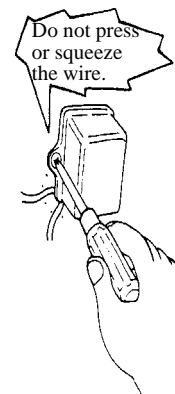

1. GENERAL INFORMATION

- After routing, check that the wire harnesses are not twisted or kinked.

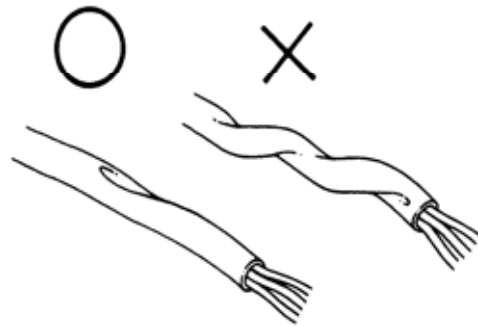

- Wire harnesses routed along with handlebar should not be pulled tight, have excessive slack or interfere with adjacent or surrounding parts in all steering positions.

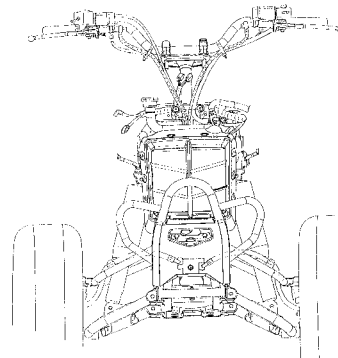

- When a testing device is used, make sure to understand the operating methods thoroughly and operate according to the operating instructions.

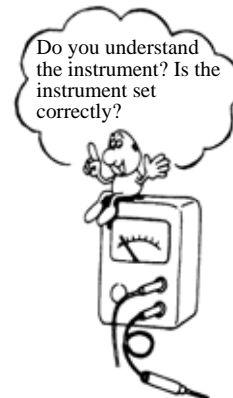

- Be careful not to drop any parts.



- When rust is found on a terminal, remove the rust with sand paper or equivalent before connecting.



1. GENERAL INFORMATION

■ Symbols:

The following symbols represent the servicing methods and cautions included in this service manual.



: Apply engine oil to the specified points. (Use designated engine oil for lubrication.)



: Apply grease for lubrication.



: Transmission Gear Oil (90#)



: Note



: Warning

1. GENERAL INFORMATION

TORQUE VALUES

STANDARD TORQUE VALUES

Item	Torque kgf-m (N-m, lbf-ft)	Item	Torque kgf-m (N-m, lbf-ft)
5mm bolt and nut	0.5 (5, 3.6)	4mm screw	0.3 (3, 2.2)
6mm bolt and nut	1 (10, 7.2)	5mm screw	0.4 (4, 2.9)
8mm bolt and nut	2.2 (22, 16)	6mm screw, SH bolt	0.9 (9, 6.5)
10mm bolt and nut	3.5 (35, 25)	6mm flange bolt and nut	1.2 (12, 9)
12mm bolt and nut	5.5 (55, 40)	8mm flange bolt and nut	2.7 (27, 20)
14mm bolt and nut	7 (70, 50)	10mm flange bolt and nut	4 (40, 29)

Torque specifications listed below are for important fasteners.

ENGINE

Item	Q'ty	Thread dia. (mm)	Torque kgf-m (N-m, lbf-ft)	Remarks
Stud bolt	4	8	0.9 (9, 6.5)	
Oil filter screen cap	1	30	1.5 (15, 11)	
Seat ball stopper bolt	1	14	4.8 (48, 35)	
L cover	8	6	1.2 (12, 8.6)	
Cam holder	4	8	2 (20, 14)	Apply oil
Tappet ADJ nut	2	6	0.9 (9, 6.5)	Apply oil
Pivot tensioner	1	8	1 (10, 7)	
Lifter tensioner	2	6	1.2 (12, 8.6)	
Lifter tensioner	1	6	0.4 (4, 2.9)	
Right crankcase bolt	9	6	1 (10, 7)	
Driver face	1	12	6 (60, 43)	Apply oil
Clutch outer	1	12	5.5 (55, 40)	
Balancer shaft nut	1	16	4.5 (45, 32)	Left threaded
Start clutch nut	1	22	9.5 (95, 68)	Apply oil, Left threaded
ACG flywheel	1	14	5.5 (55, 40)	
Spark plug	1	8	1.5 (15, 11)	
Drain bolt mission	1	8	1 (10, 7)	
Drain plug	1	12	2.5 (25, 18)	
Motor srart	2	6	1 (10, 7)	
Oil pump	2	6	1 (10, 7)	
Oil pump sprocket	2	6	1 (10, 7)	
Head CYL bolt	2	6	1 (10, 7)	
Drive plate nut	1	28	5.5 (55, 40)	
Stator	4	5	1 (10, 7)	

1. GENERAL INFORMATION

ENGINE (Cont'd)

Item	Q'ty	Thread dia. (mm)	Torque kgf-m (N-m, lbf-ft)	Remarks
R cover	9	6	1 (10, 7)	
Head cover	4	6	1 (10, 7)	
Cap R cover	1	6	1 (10, 7)	
Guide star change handle	3	6	1 (10, 7)	
Sprocket drive plate	2	6	1 (10, 7)	
Carburetor	2	6	1 (10, 7)	
Transmission oil check bolt	1	10	1.2 (12, 9)	

FRAME

Item	Q'ty	Thread dia. (mm)	Torque kgf-m (N-m, lbf-ft)	Remarks
Steering stem nut	1	14	7 (70, 50)	
Swing arm nut	4	10	4.5 (45, 32)	
Rear wheel nut	2	14	7 (70, 50)	
Front wheel nut	2	14	7 (70, 50)	
Rear shock absorber upper mount bolt	1	10	4 (40, 29)	
Front shock absorber upper mount bolt	2	10	4 (40, 29)	
Front shock absorber lower mount bolt	2	10	4 (40, 29)	
Rear fork axle	1	14	7 (70, 50)	
Rear hub nut	4	12	7 (70, 50)	
Rear wheel shaft nut	2	32	12 (120, 86)	
Rear engine bracket up bolt	1	10	4 (40, 29)	
Rear engine bracket bolt	1	10	4 (40, 29)	
Engine hanger bracket bolt	1	10	4 (40, 29)	
Exhaust muffler lock bolt	2	8	3.5 (35, 25)	

1. GENERAL INFORMATION

SPECIAL TOOLS

Tool Name	Tool No.	Remarks
Flywheel puller	E003	Flywheel removal
Lock nut wrench	E009	Start clutch nut removal/installation
Lock nut wrench	E010	Balancer gear nut removal/installation
Valve adjuster	E012	Valve clearance adjustment
Valve spring compressor	E040	Cylinder head disassembly/assembly
Oil seal and bearing install	E014	
Universal holder	E017	Clutch outer nut removal/installation
Flywheel holder	E021	Flywheel nut removal/installation
Clutch spring compressor	E034	Driven pulley clutch removal/installation
Bearing puller	E037	
Nut wrench	F010	Rear axle nut removal/installation

1. GENERAL INFORMATION

LUBRICATION POINTS

ENGINE

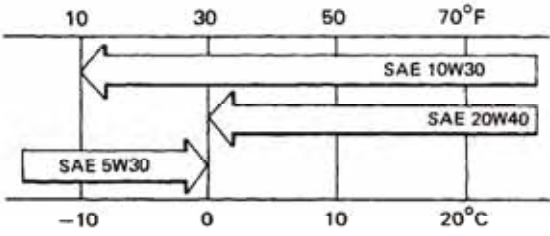
Lubrication Points	Lubricant
Valve guide/valve stem movable part Cam lobes Valve rocker arm friction surface Cam chain Cylinder lock bolt and nut Piston surroundings and piston ring grooves Piston pin surroundings Cylinder inside wall Connecting rod/piston pin hole Connecting rod big end Crankshaft right side oil seal Crankshaft one-way clutch movable part Oil pump drive chain Balance gear A.C. generator Starter one-way clutch Bearing movable part O-ring face Oil seal lip	<ul style="list-style-type: none"> •Genuine KYMCO Engine Oil (SAE15W-40) •API SG Engine Oil 
Transmission gear and movable parts	Gear oil: SAE90#

1. GENERAL INFORMATION

FRAME

The following is the lubrication points for the frame.

Use general purpose grease for parts not listed.

Apply clean engine oil or grease to cables and movable parts not specified. This will avoid abnormal noise and rise the durability of the motorcycle.

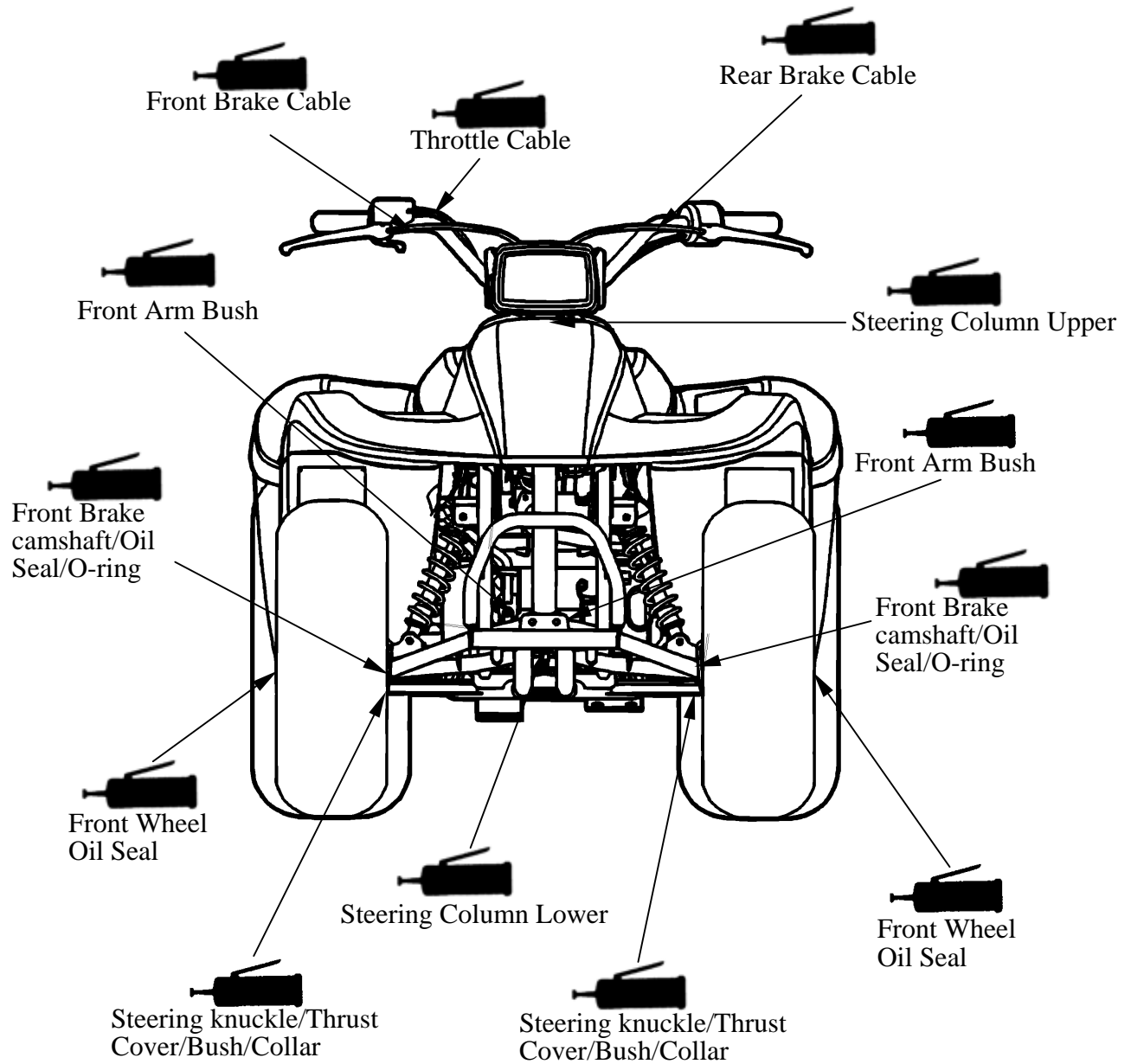

1. GENERAL INFORMATION

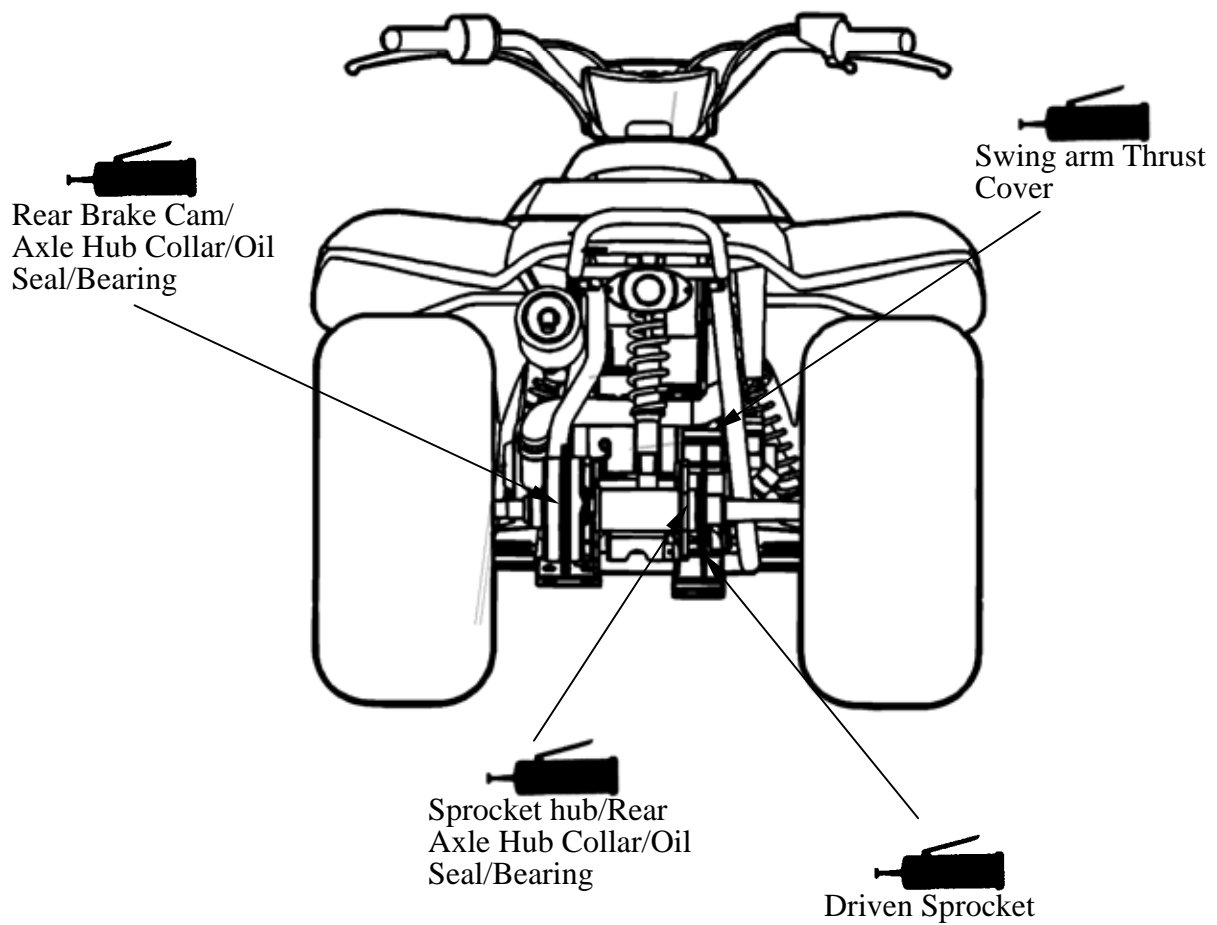

1. GENERAL INFORMATION

CABLE & HARNESS ROUTING (MX'er 150/125)

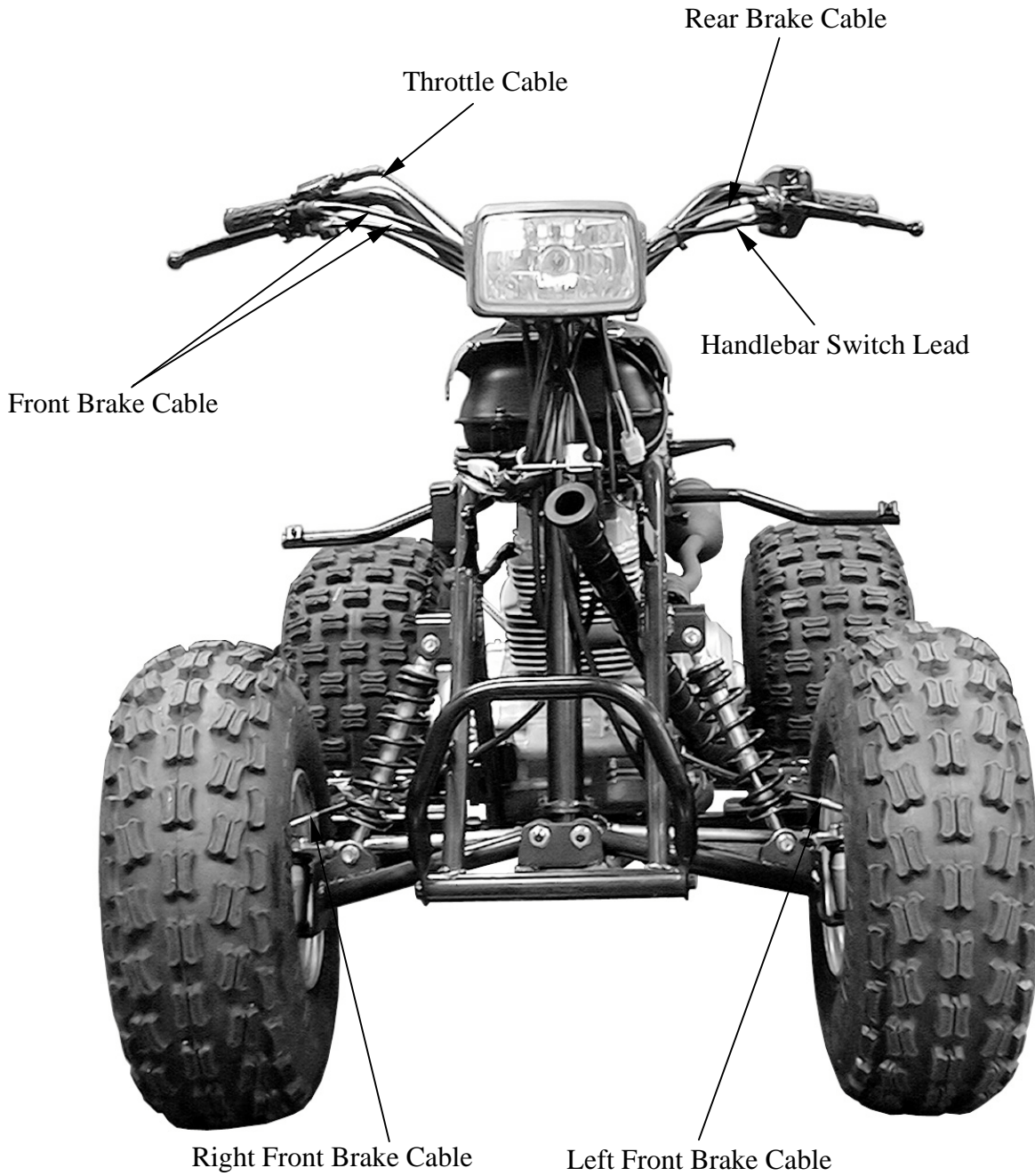

1. GENERAL INFORMATION

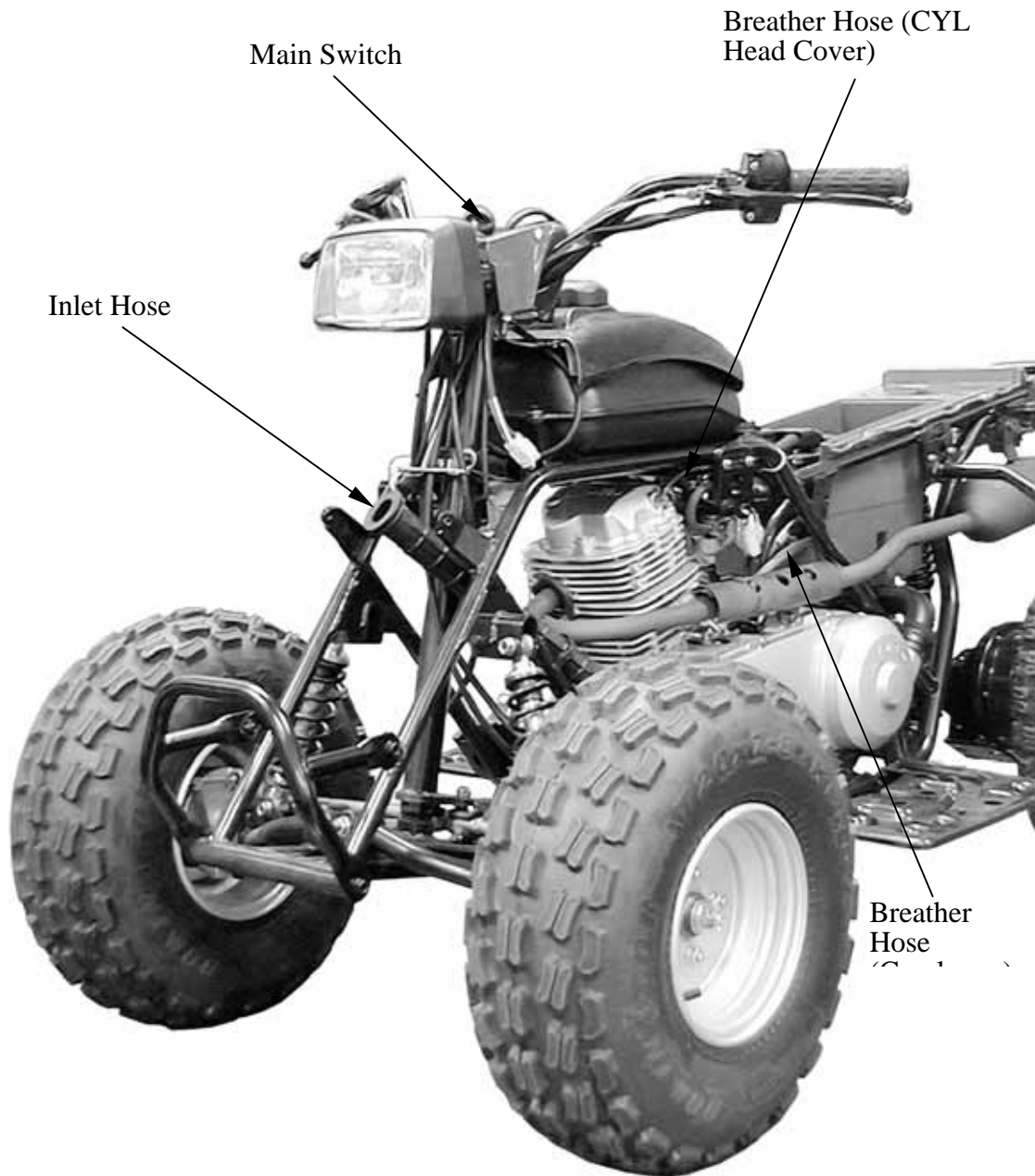

1. GENERAL INFORMATION



1. GENERAL INFORMATION

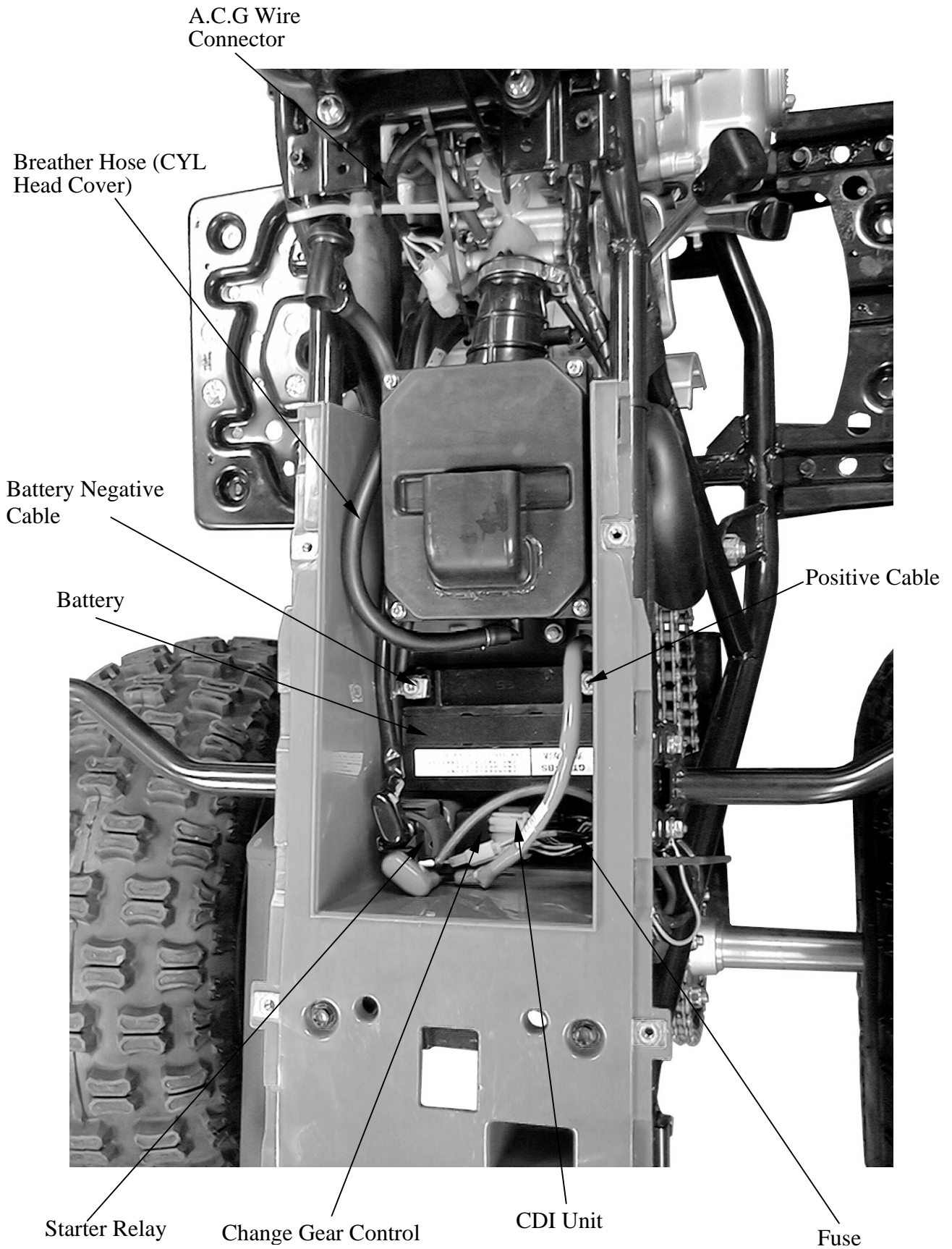

1. GENERAL INFORMATION

CABLE & HARNESS ROUTING (MXU 150)

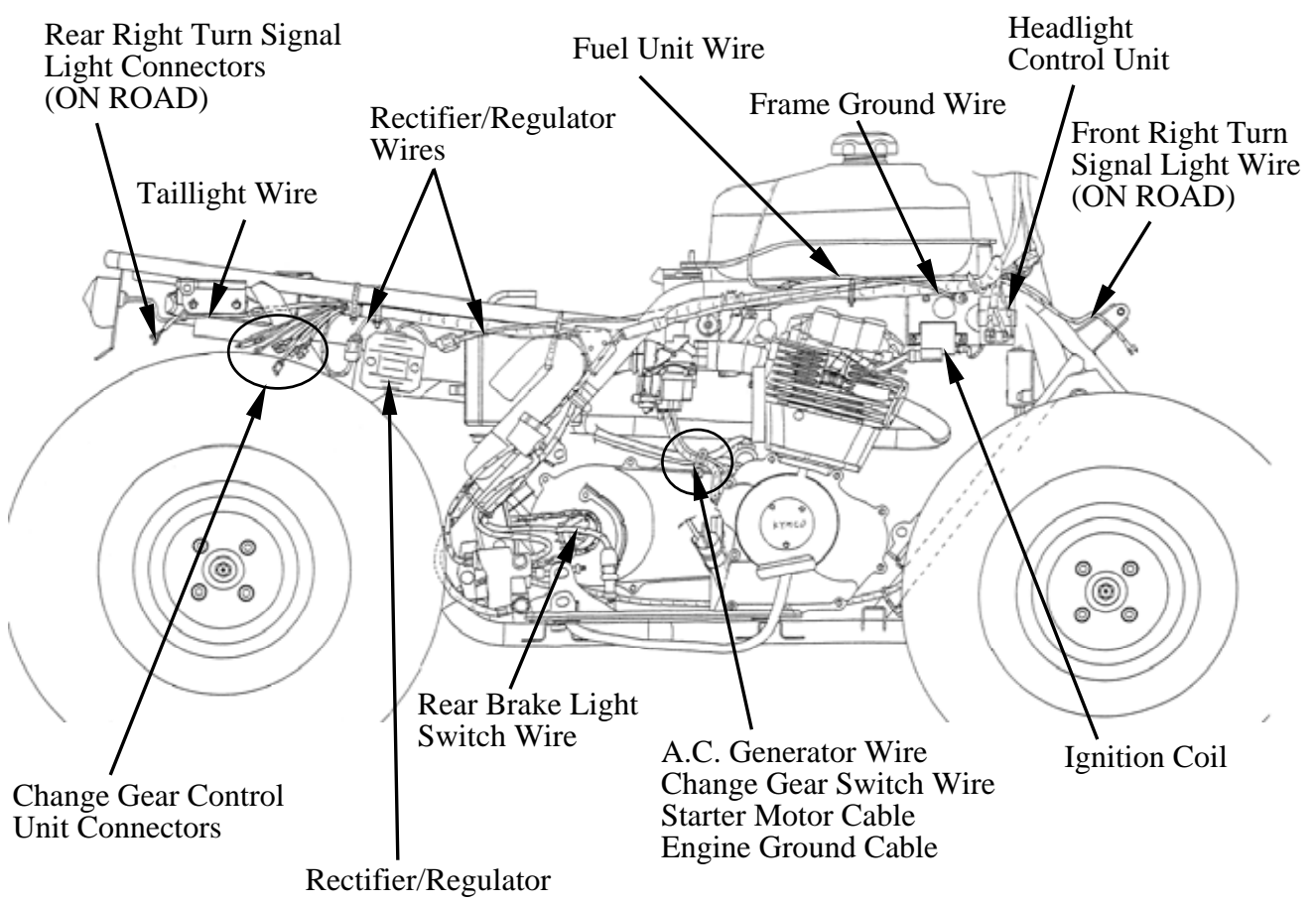
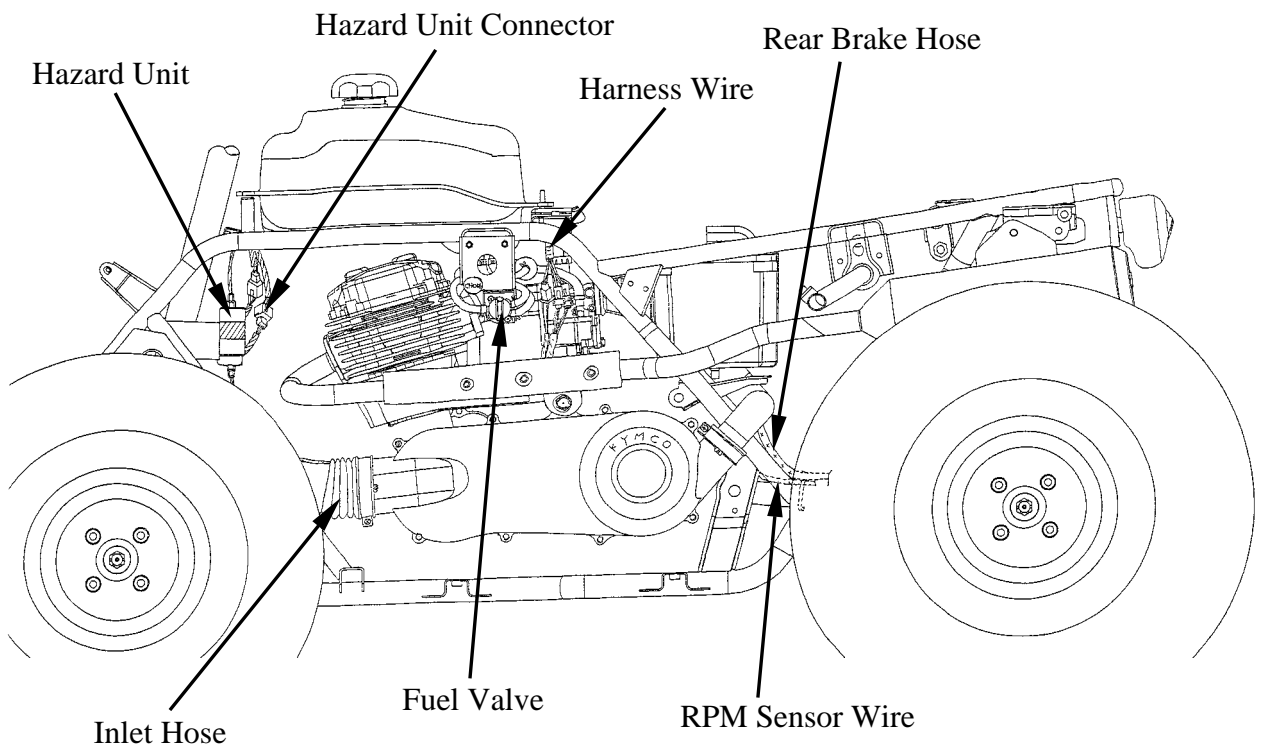

1. GENERAL INFORMATION

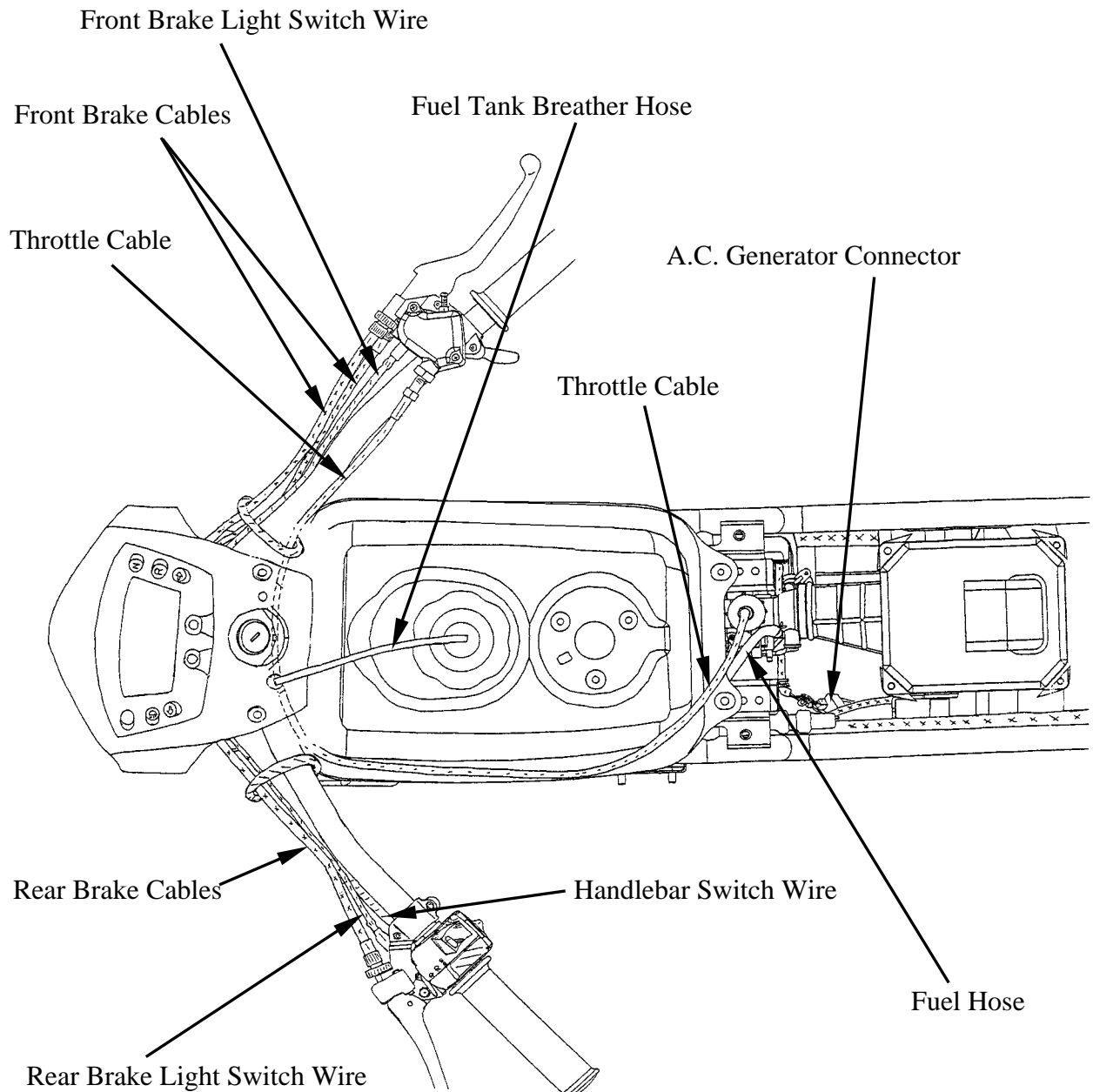

1. GENERAL INFORMATION

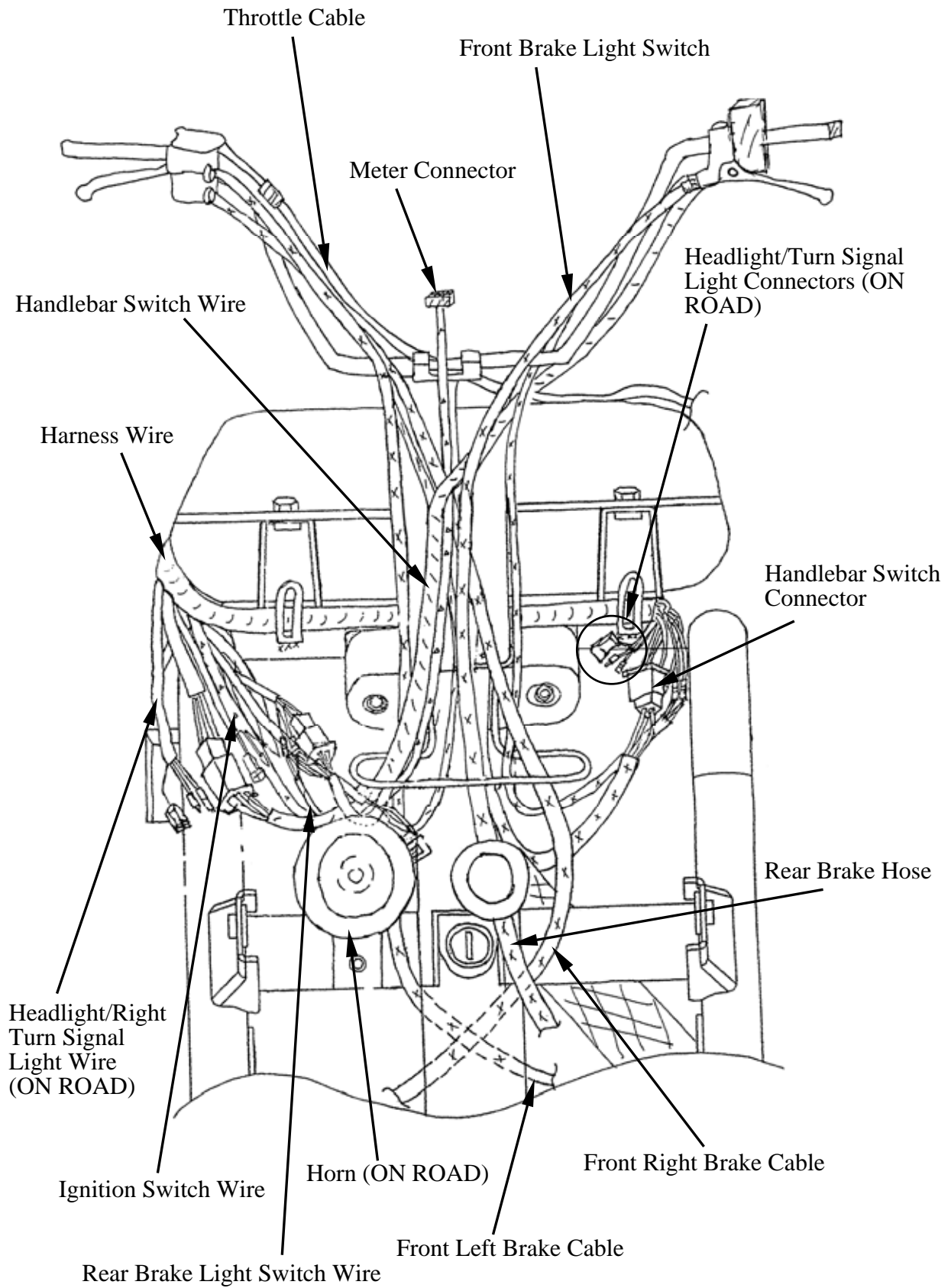

1. GENERAL INFORMATION

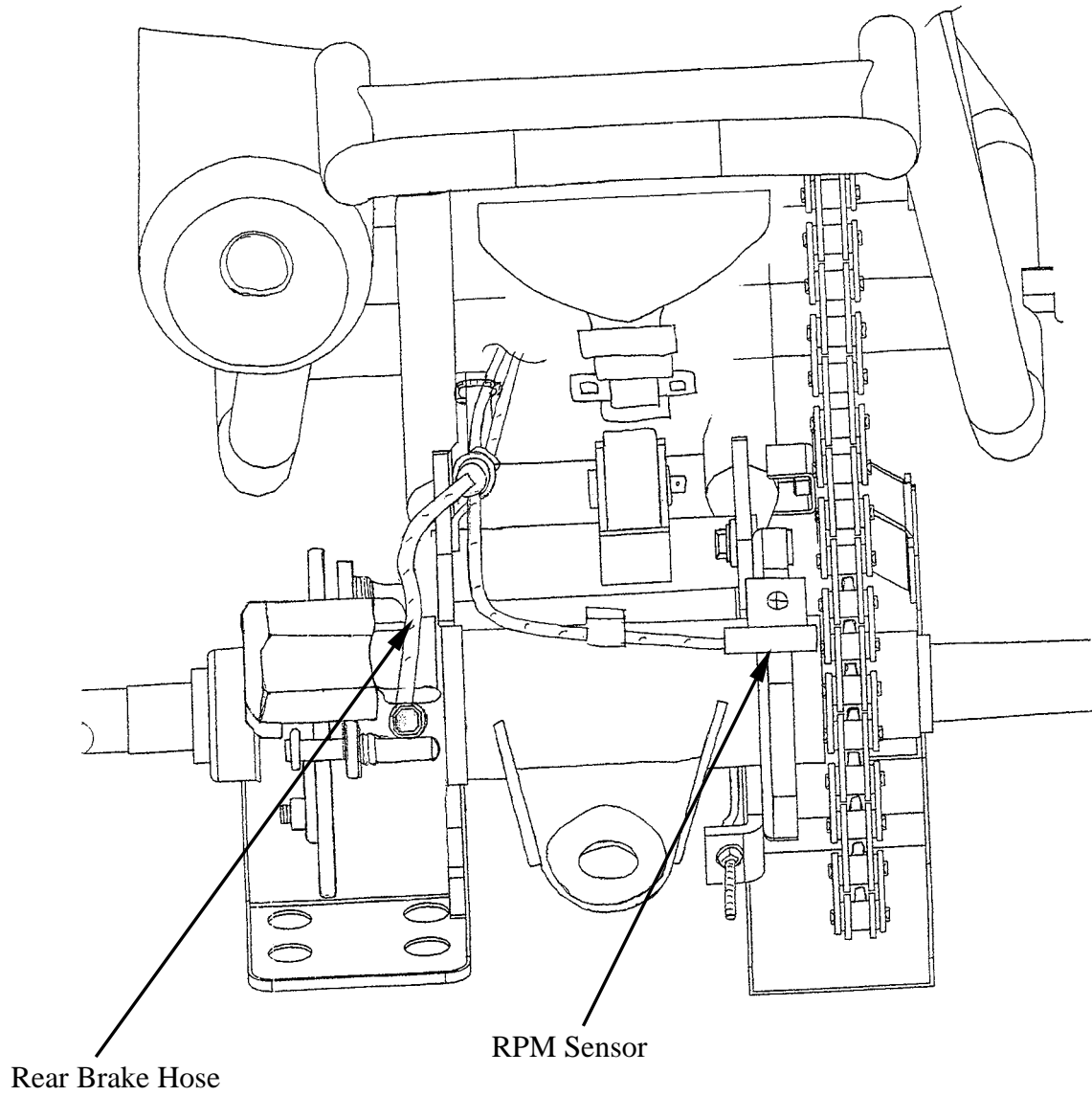

1. GENERAL INFORMATION

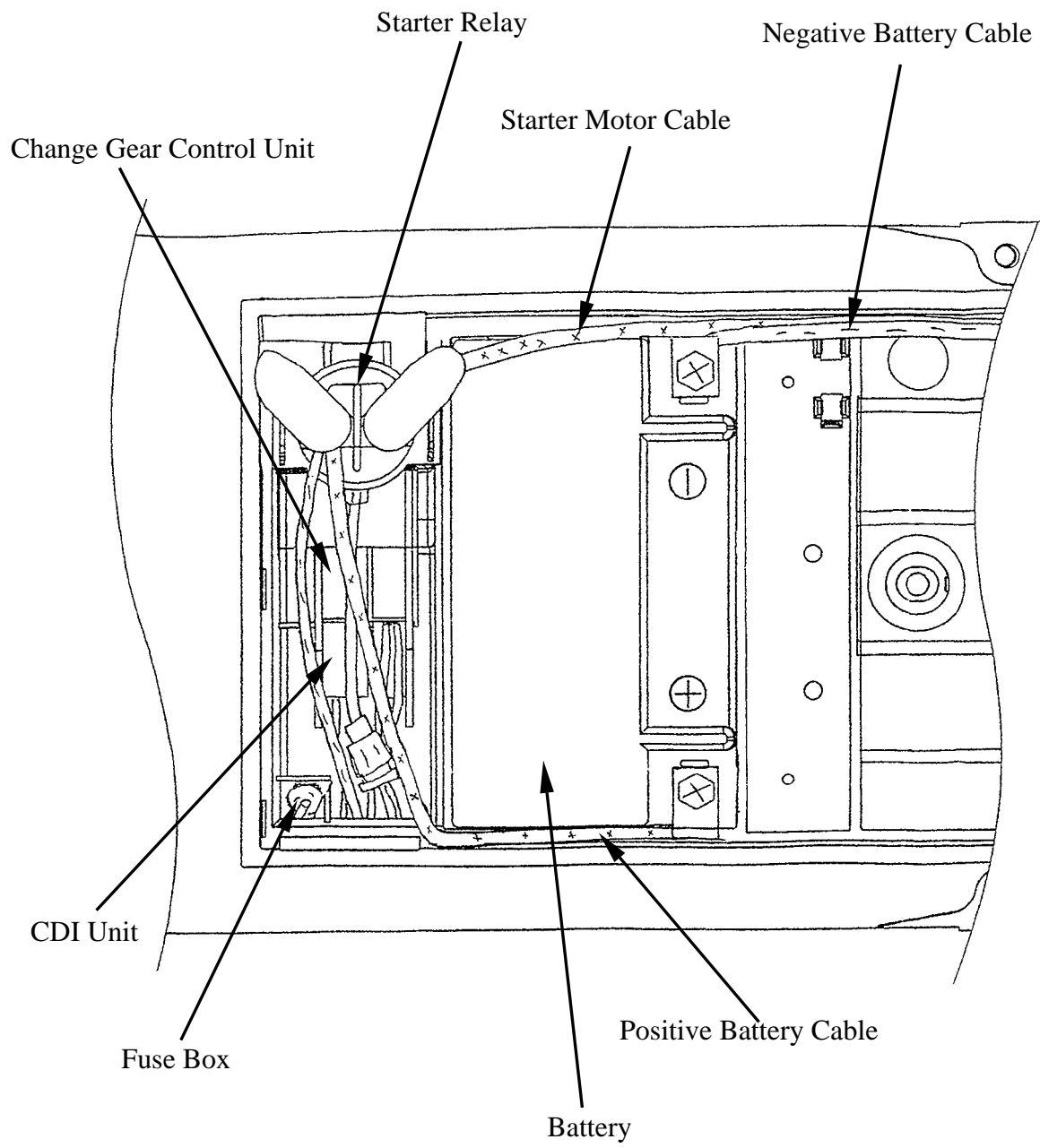

1. GENERAL INFORMATION

WIRING DIAGRAM (MX'er 150/125 ON ROAD)

HORN SW	
HO	BAT
FREE	○
PUSH	○
COLOR	LG B

START SW	
ST	C
FREE	○
PUSH	○
COLOR	Y/R/Y/R

WINKER SW	
R	L
WR	○
○	○
COLOR	SB O GR

DIMMER SW	
HL	LO
HI	○
○	○
COLOR	B W L

HAZARD SW	
BAT	HA
○	○
COLOR	R Y/B

COMB SW	
BAT1	IG
ON	○
OFF	○
LOCK	○
COLOR	R B/W G B

B	BLACK	BR	BROWN
G	GREEN	GB	BROWN
O	ORANGE	SB	SKY BLUE
L	BLUE	LG	LIGHT GREEN
Y	YELLOW	Y/R	YELLOW
R	RED		

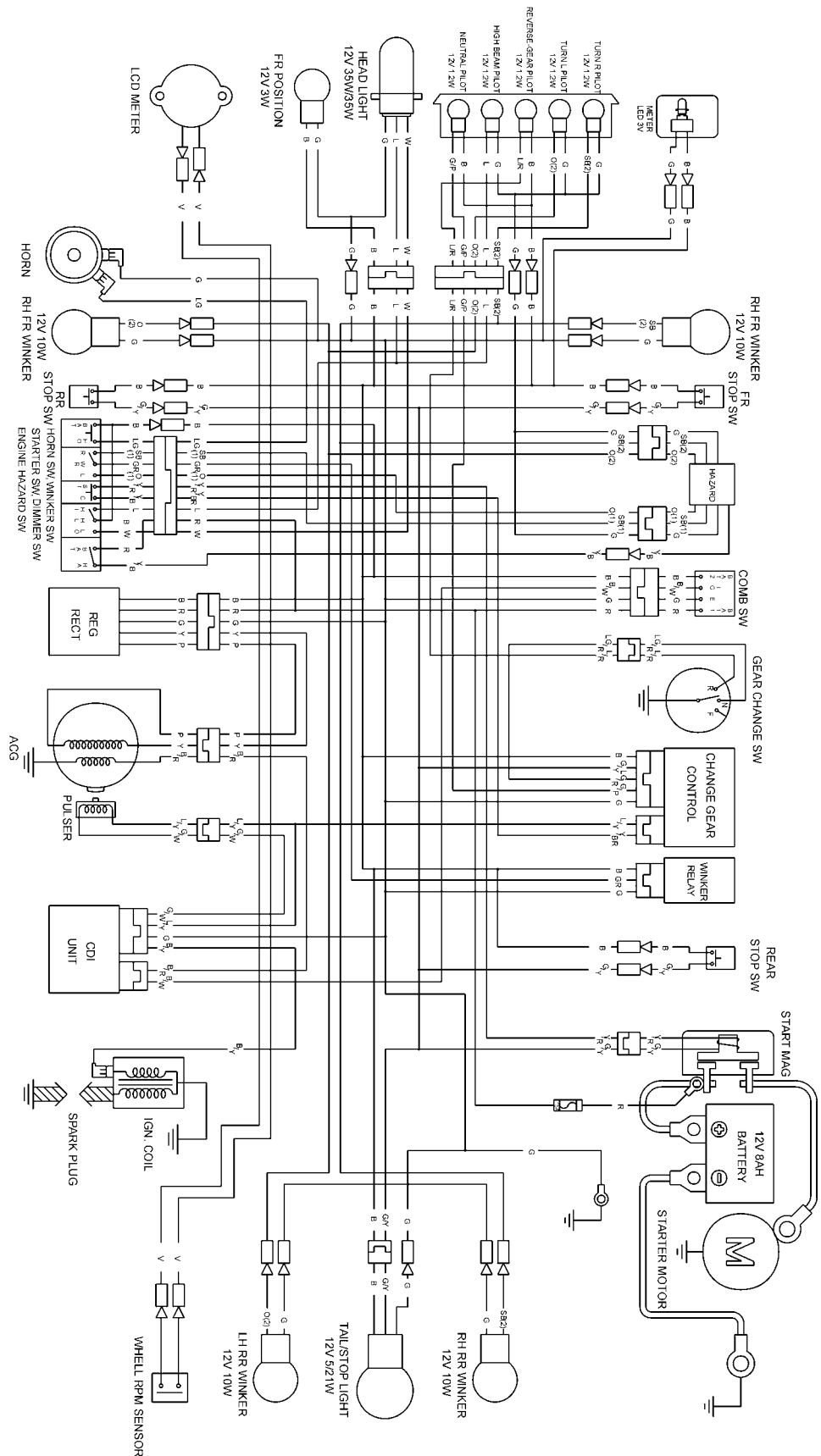

1. GENERAL INFORMATION

(MX'er 150/125 OFF ROAD)

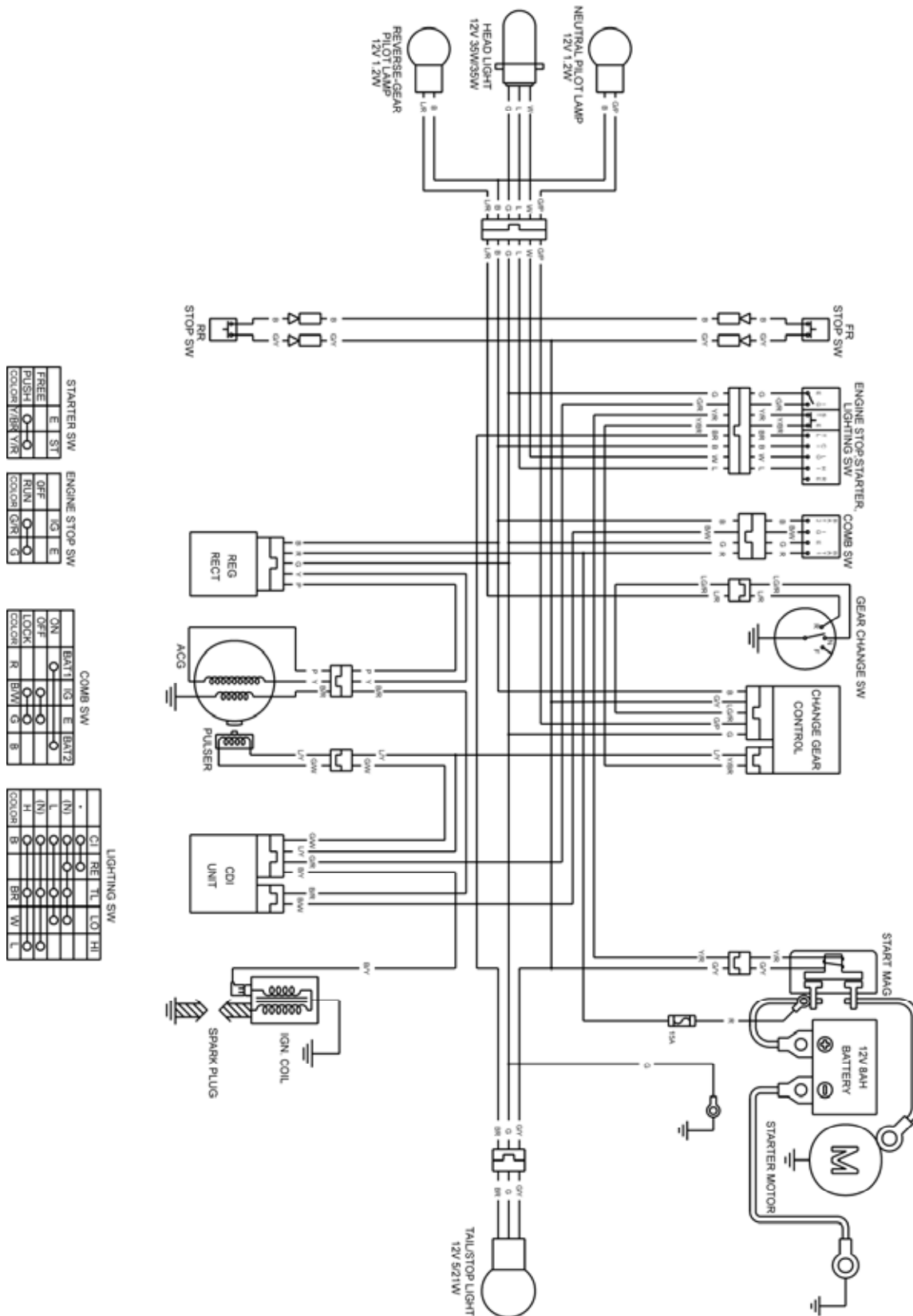

1. GENERAL INFORMATION

(MXU 150 OFF ROAD)

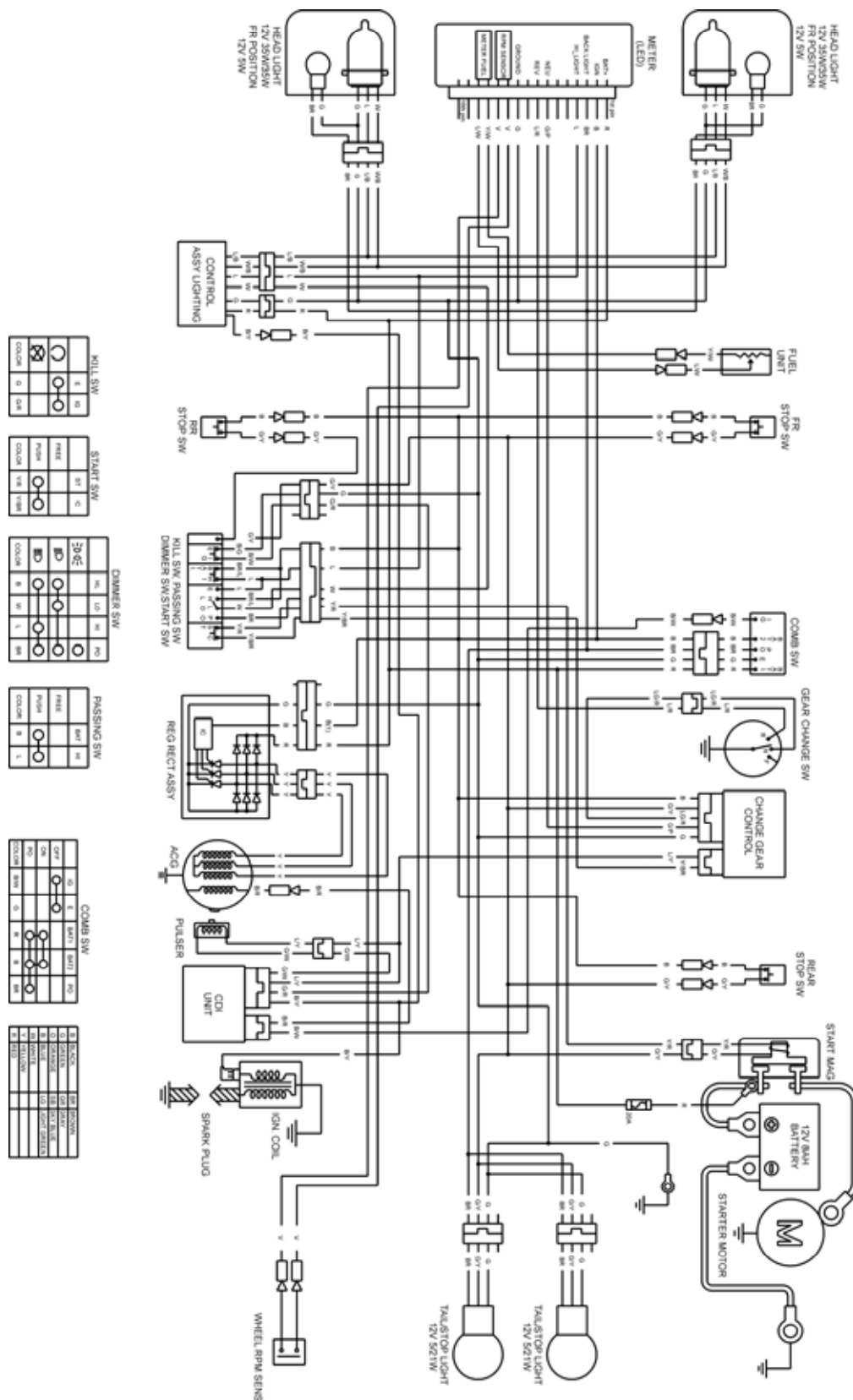

1. GENERAL INFORMATION

TROUBLESHOOTING

ENGINE WILL NOT START OR IS HARD TO START

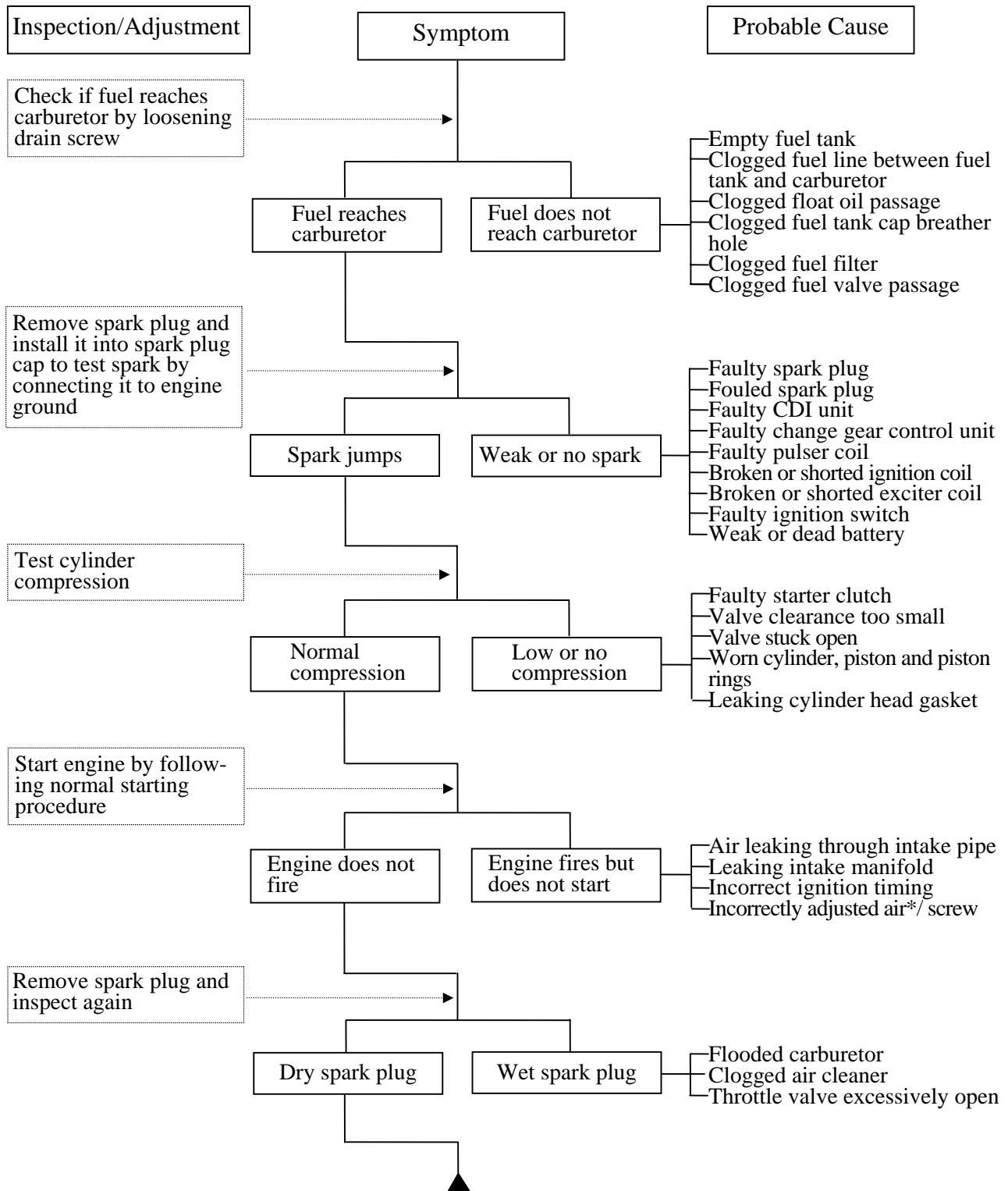

1. GENERAL INFORMATION

ENGINE LACKS POWER

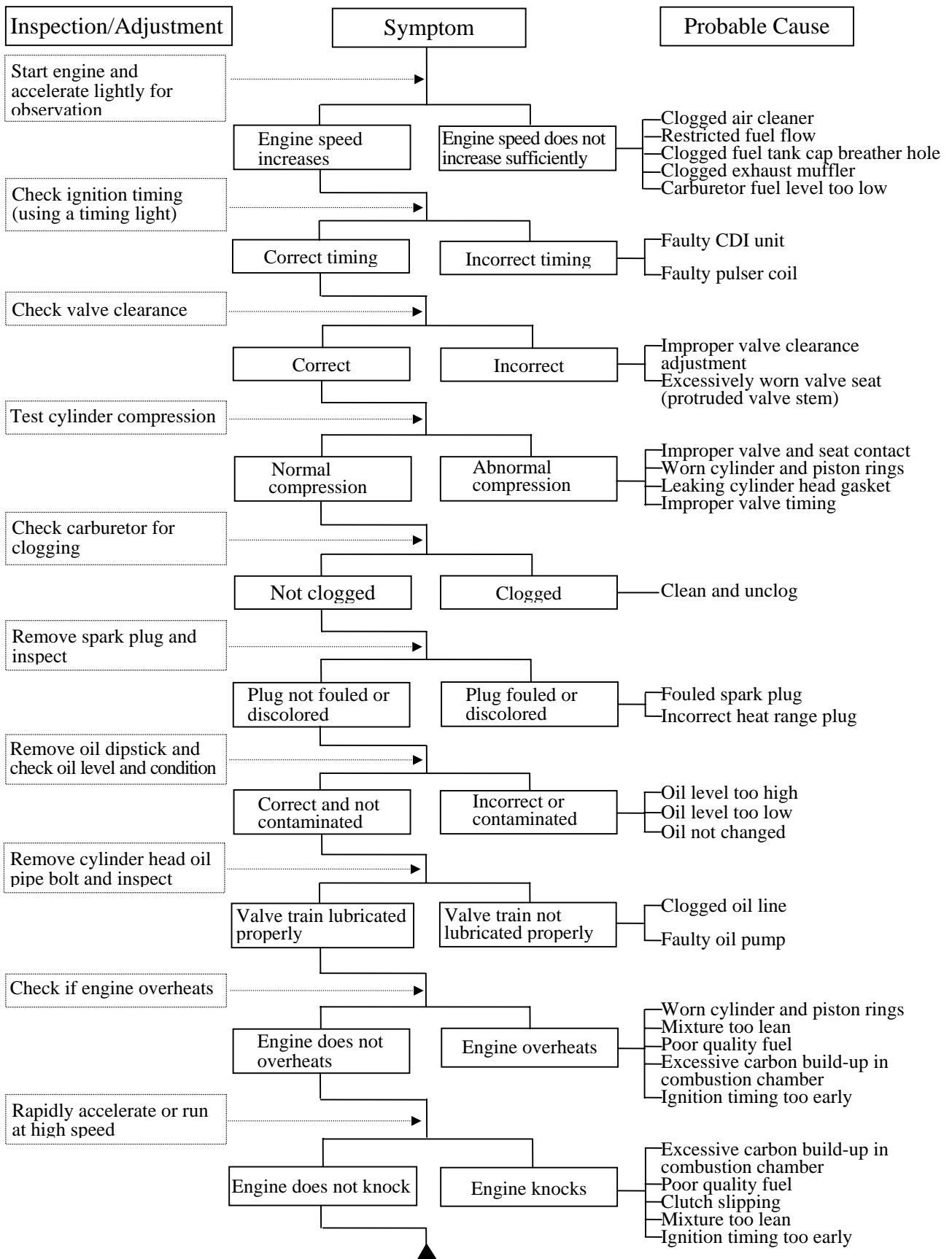

1. GENERAL INFORMATION

POOR PERFORMANCE (ESPECIALLY AT IDLE AND LOW SPEEDS)

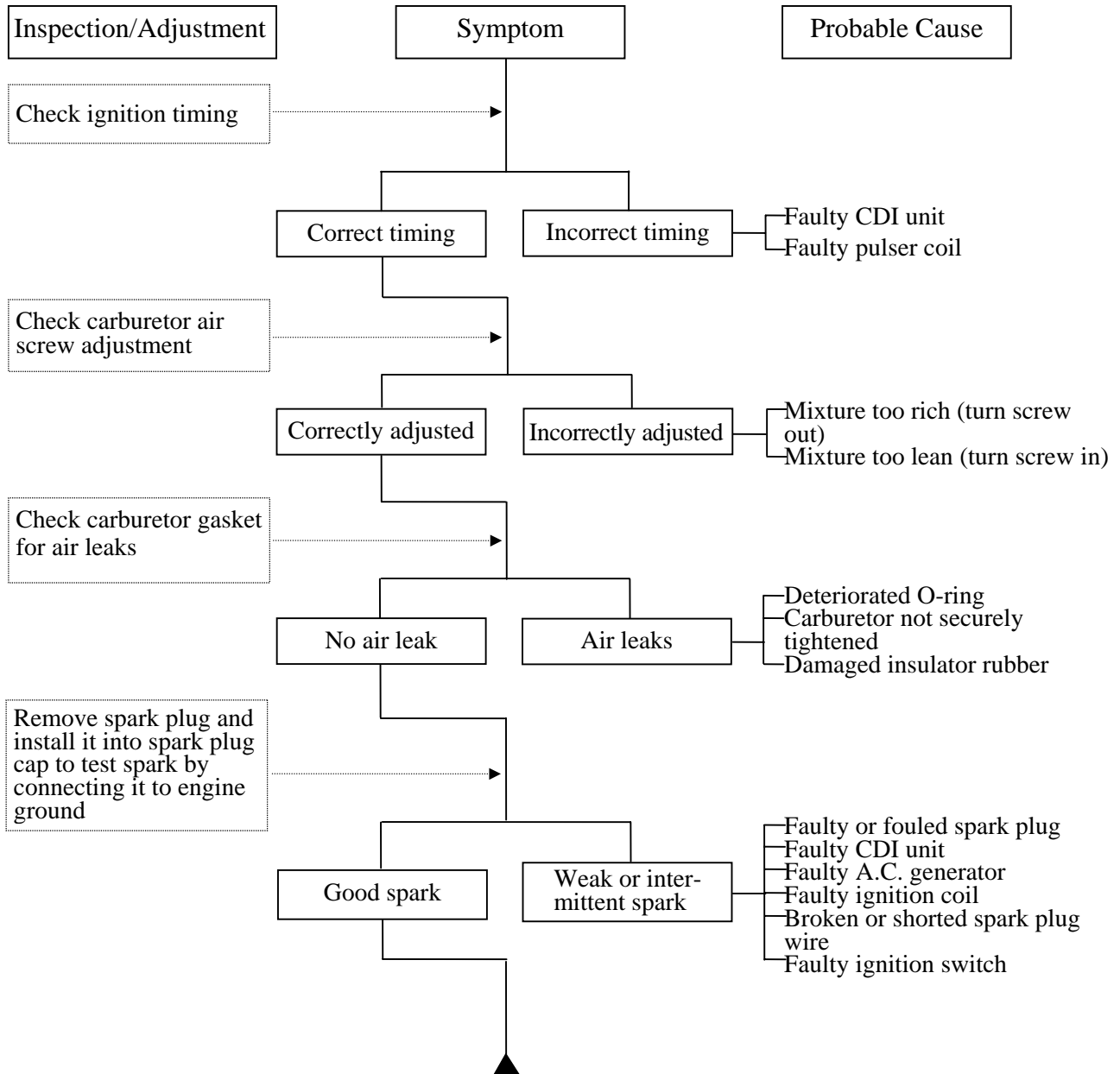

1. GENERAL INFORMATION

POOR PERFORMANCE (AT HIGH SPEED)

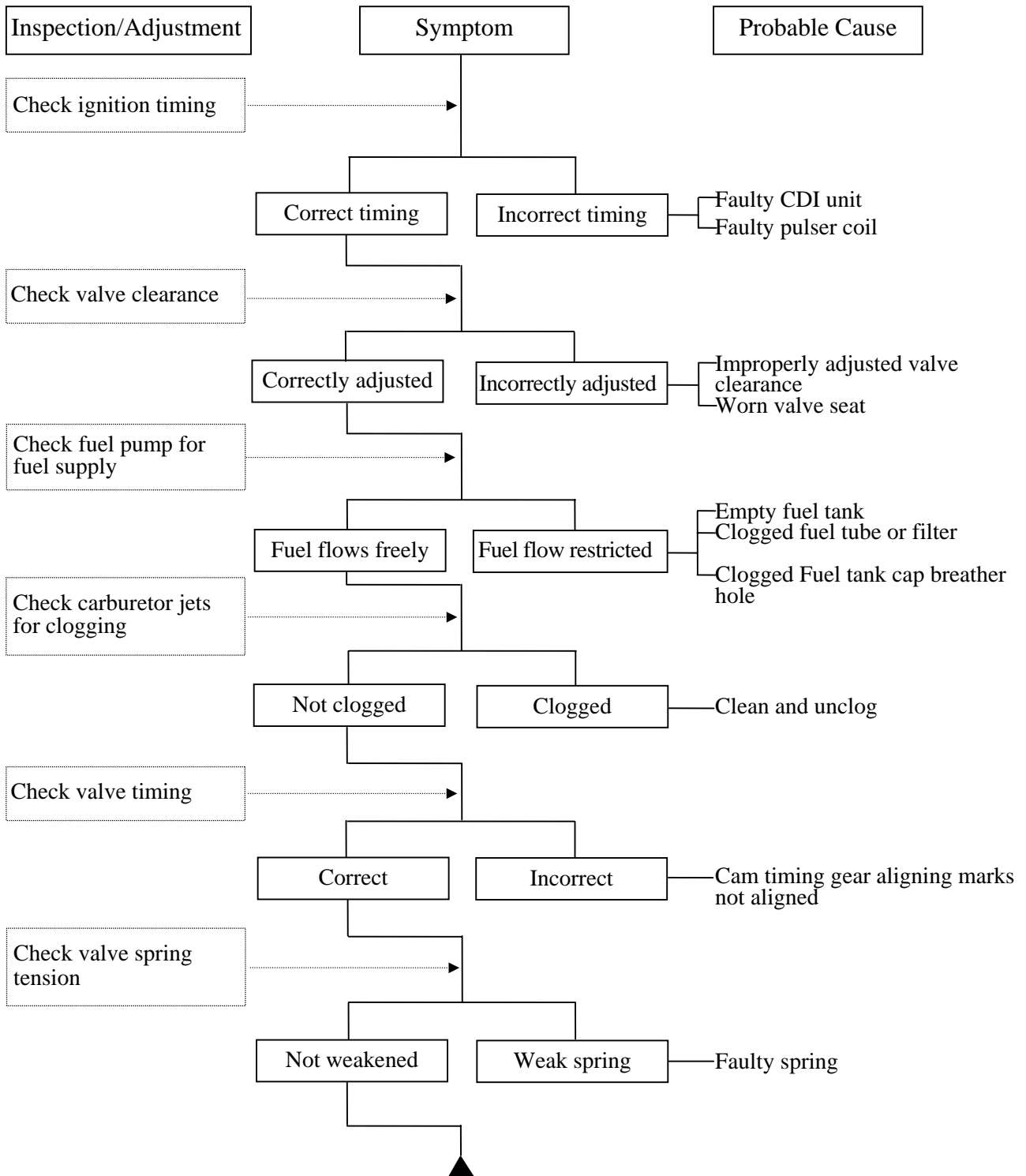

1. GENERAL INFORMATION

POOR CHARGING (BATTERY OVER DISCHARGING OR OVERCHARGING)

Undercharging

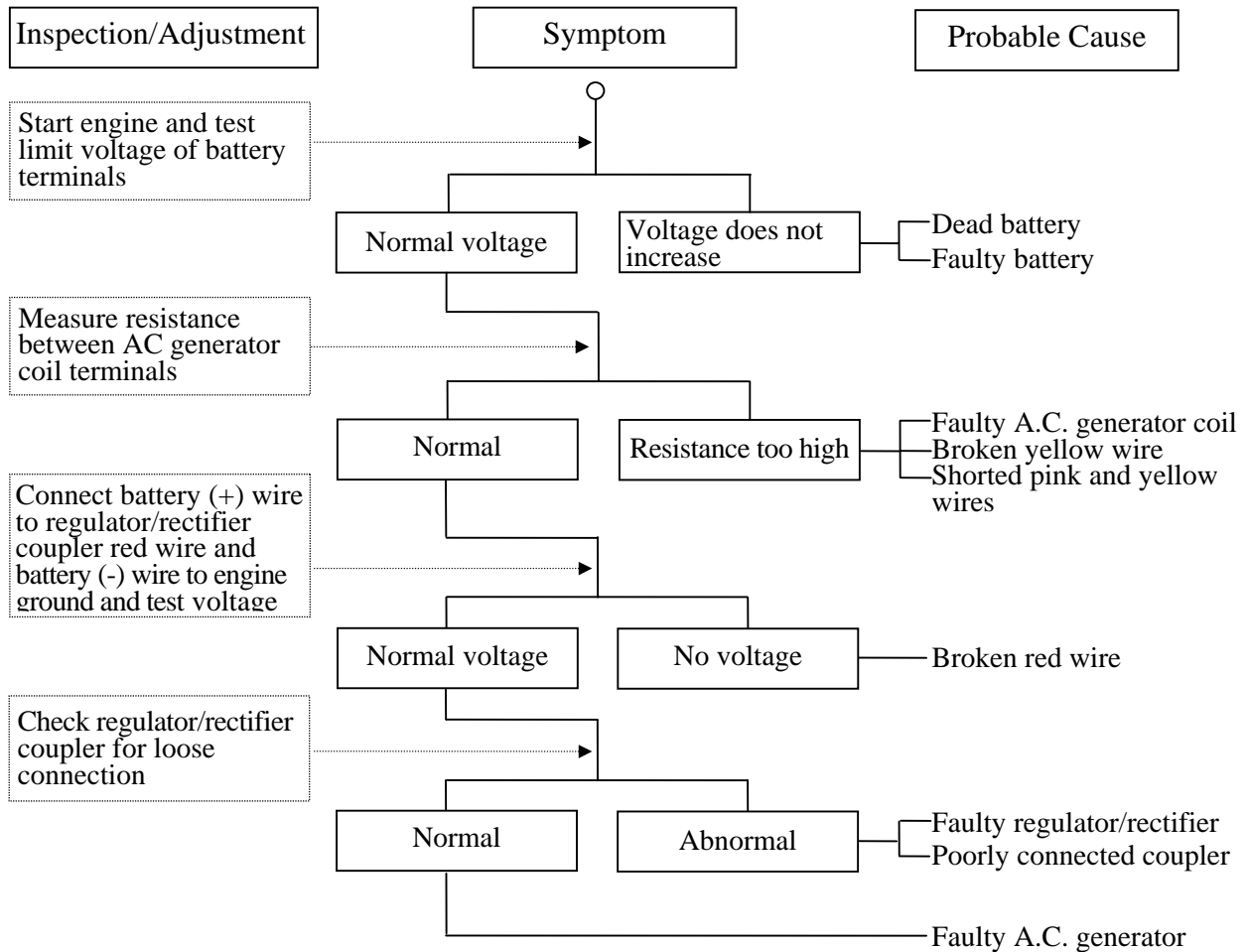

Overcharging

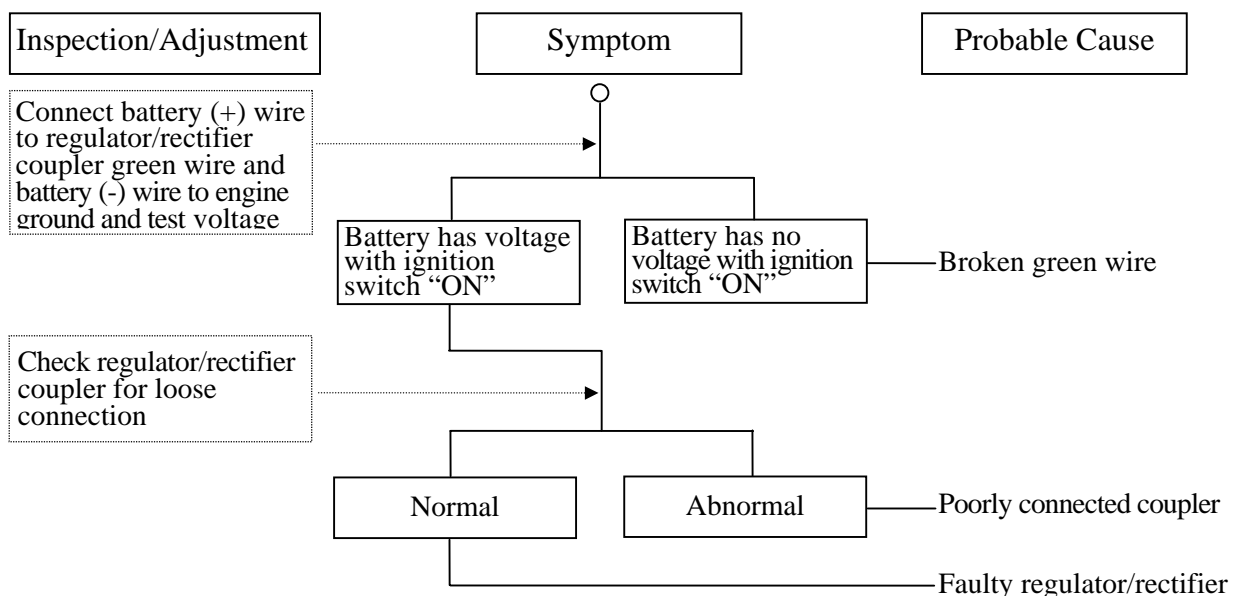

1. GENERAL INFORMATION

NO SPARK AT SPARK PLUG

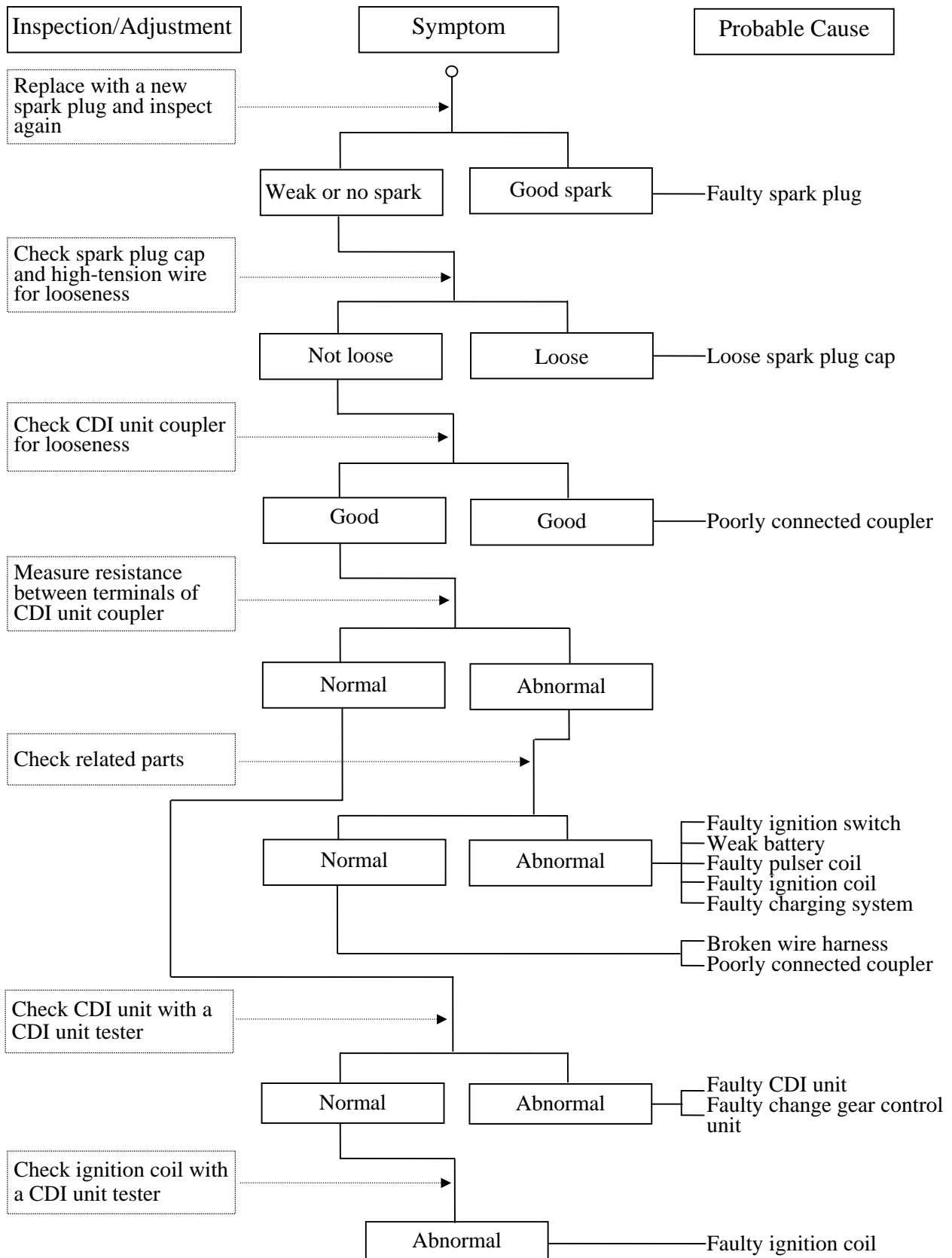

2. FRAME COVERS/EXHAUST MUFFLER

2

FRAME COVERS/EXHAUST MUFFLER

SERVICE INFORMATION-----	2-	1
TROUBLESHOOTING-----	2-	1
FRAME COVERS (MX'er 150/125) -----	2-	3
HEADLIGHT REMOVAL (MX'er 150/125)-----	2-	5
FASTENER REMOVAL AND REINSTALLATION-----	2-	7
FRAME COVERS (MXU 150) -----	2-	8
EXHAUST MUFFLER REMOVAL-----	2-	16

2. FRAME COVERS/EXHAUST MUFFLER

SERVICE INFORMATION

GENERAL INSTRUCTIONS

- When removing frame covers, use special care not to pull them by force because the cover joint claws may be damaged.
- Make sure to route cables and harnesses according to the Cable & Harness Routing.

TORQUE VALUES

Exhaust muffler lock bolt	3.5 kgf-m (35 N-m, 25 lbf-ft)
Exhaust muffler joint lock nut	1 kgf-m (10 N-m, 7.2 lbf-ft)

TROUBLESHOOTING

Noisy exhaust muffler

- Damaged exhaust muffler
- Exhaust muffler joint air leaks

Lack of power

- Caved exhaust muffler
- Exhaust muffler air leaks
- Clogged exhaust muffler

2. FRAME COVERS/EXHAUST MUFFLER

MX'er 150/125

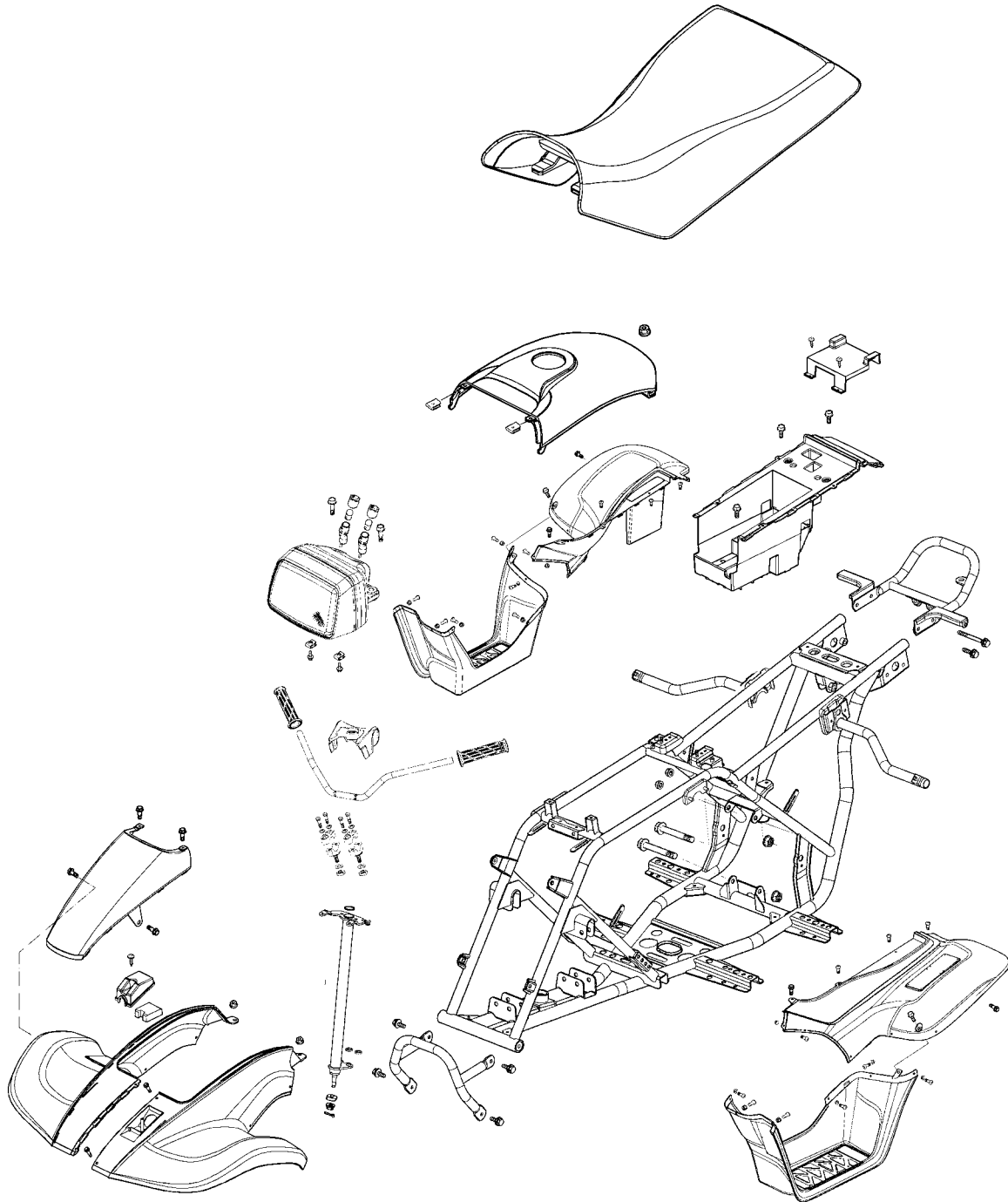

2. FRAME COVERS/EXHAUST MUFFLER

FRAME COVERS (MX'er 150/125)

SEAT REMOVAL

Pull the lever backward, then pull up the seat at the rear.
Remove the seat.

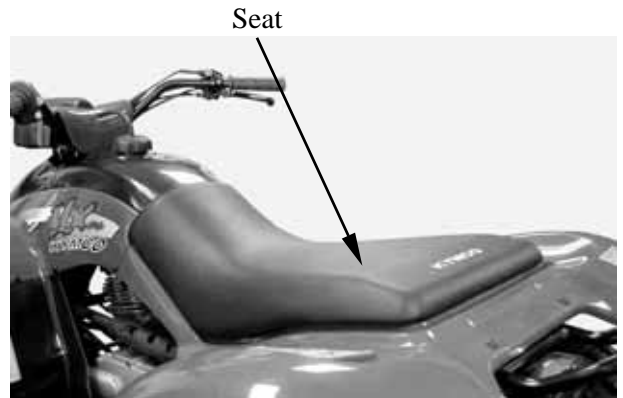

LEFT REAR FENDER REMOVAL

Remove seven screws and two bolts attaching the left rear fender.

* During removal, do not pull the joint claws forcedly to avoid damage.

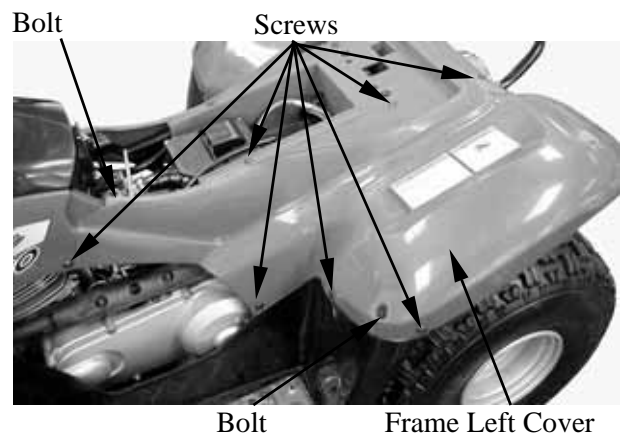

Remove the left rear fender under bolt.
Remove the left rear fender.

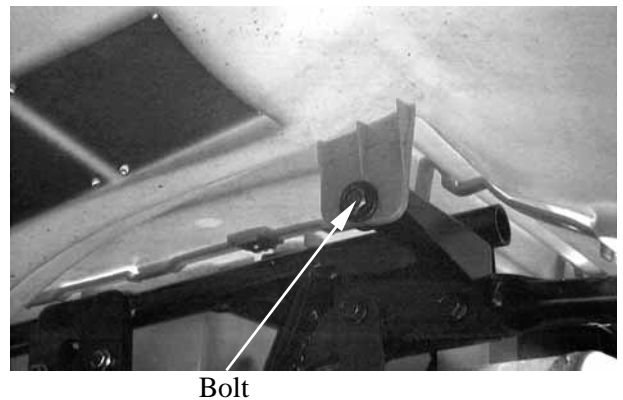

RIGHT REAR FENDER REMOVAL

Remove seven screws and two bolts attaching the right rear fender.

* During removal, do not pull the joint claws forcedly to avoid damage.

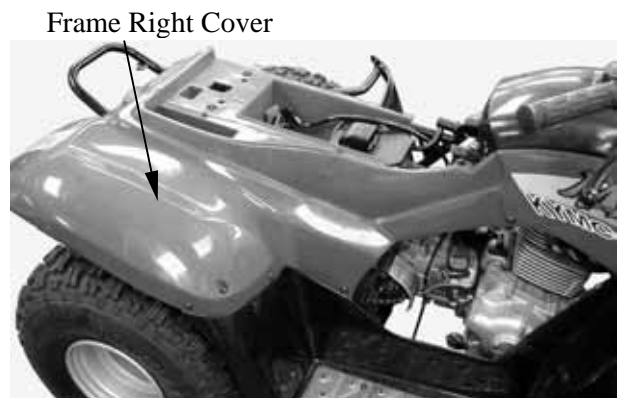

2. FRAME COVERS/EXHAUST MUFFLER

Remove right rear fender under bolt.
Remove the right rear fender.



Bolt

FLOOR BOARD COVER REMOVAL

Remove the four bolts on the floorboard cover.
Remove the floorboard cover.

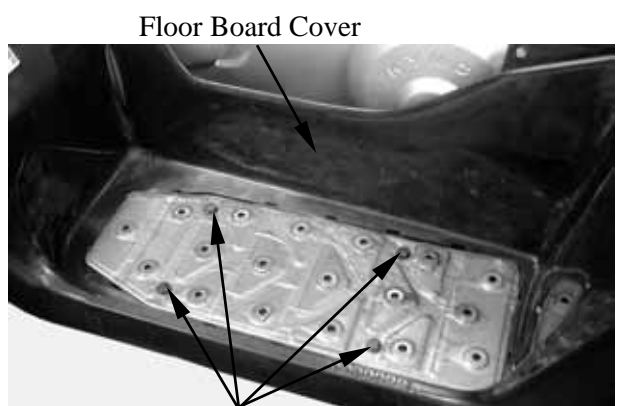

Floor Board Cover

Bolts

FRONT COVERS REMOVAL

Remove the two screws on the front cover.
Remove the left and right front fender under bolt.
Remove the front cover.



Front Cover

Screws

FRONT FENDER REMOVAL

Remove the left and right front fender under bolt.
Remove screws attaching the left and right front fender.
Remove the left and right front fender.

* During removal, be careful not to damage the joint claws.



Bolt

2. FRAME COVERS/EXHAUST MUFFLER

HEADLIGHT REMOVAL (MX'er 150/125)

Remove the headlight connector wire.
Remove the two bolts on the headlight.



Bolts

2. FRAME COVERS/EXHAUST MUFFLER

MXU 150

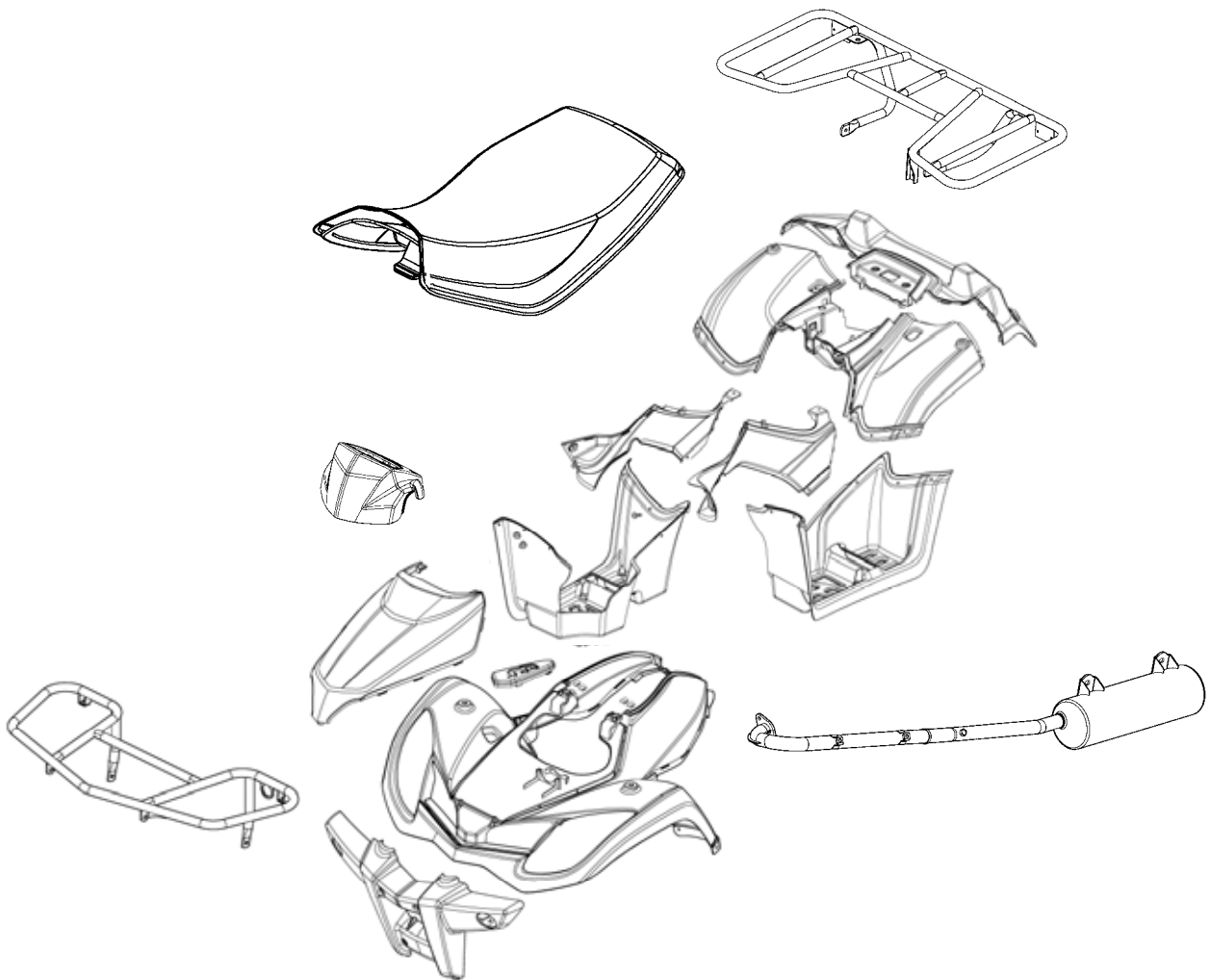

2. FRAME COVERS/EXHAUST MUFFLER

FASTENER REMOVAL AND REINSTALLATION

REMOVAL

Depress the head of fastener center piece ①.
Pull out the fastener.

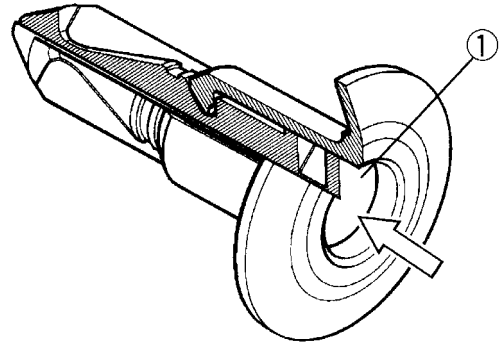

INSTALLATION

Let the center piece stick out toward the head so that the pawls ② close.
Insert the fastener into the installation hole.

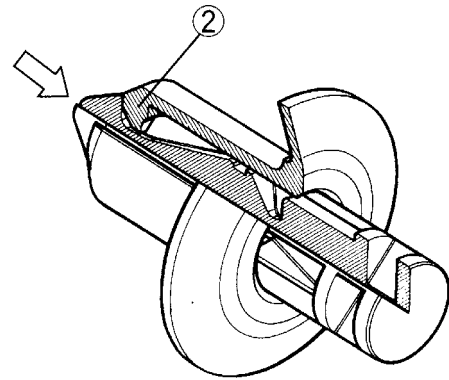

* To prevent the pawl ② from damage, insert the fastener all the way into the installation hole

Push in the head of center piece until it becomes flush with the fastener outside face.

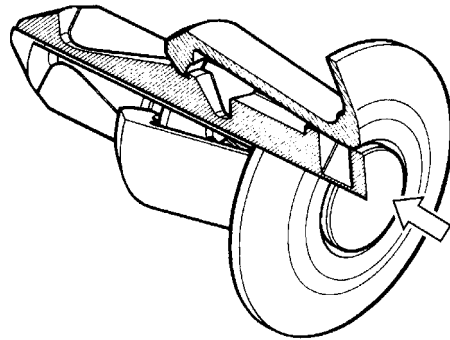

2. FRAME COVERS/EXHAUST MUFFLER

FRAME COVERS (MXU 150)

SEAT

REMOVAL

Pull the lever (1) backward, then pull up the seat at the rear.
Remove the seat.



INSTALLATION

To install the seat, align the tabs on the seat with the grommets on the frame and press the seat down until it locks.

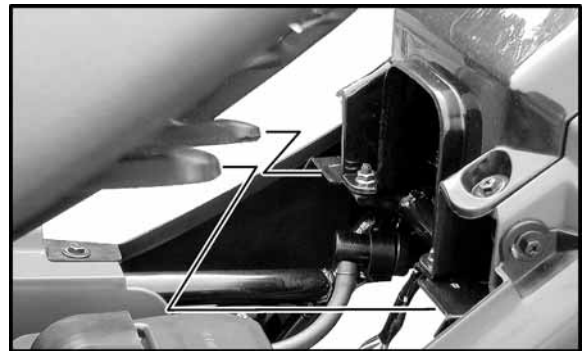

FRONT CARGO RACK

REMOVAL/INSTALLATION

Remove the two mounting bolts and two bolts under front fender

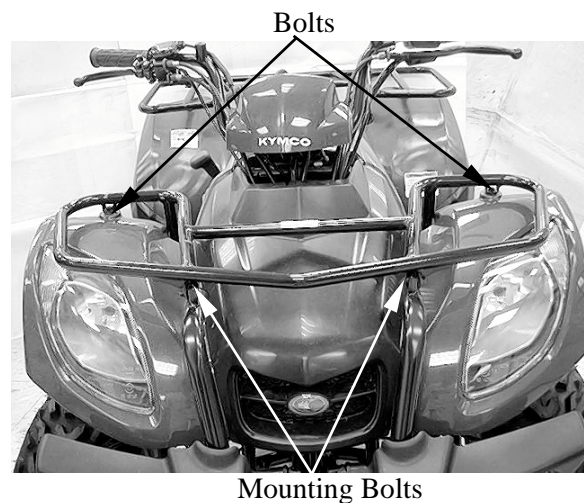

2. FRAME COVERS/EXHAUST MUFFLER

Remove the two mounting bolts from the front cargo rack right/left side under the front fender, remove the front cargo rack.

Installation is in the reverse order of removal.

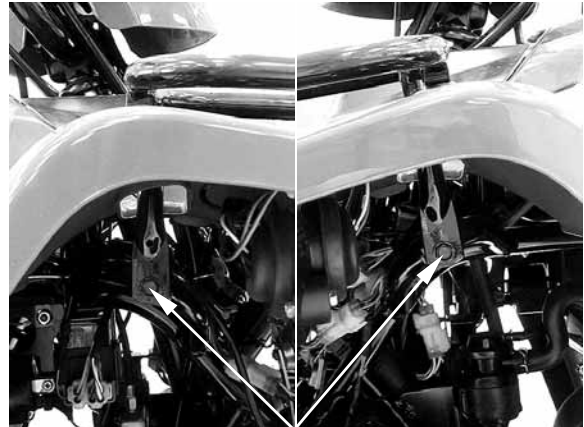

Mounting Bolts

FRONT CARRIER REMOVAL/INSTALLATION

Remove front cargo rack (see page 2-8).

Disconnect the right and left signal light connectors. (ON ROAD)
Remove the bolt from the right headlight case.

Right/Left Signal Light Connectors

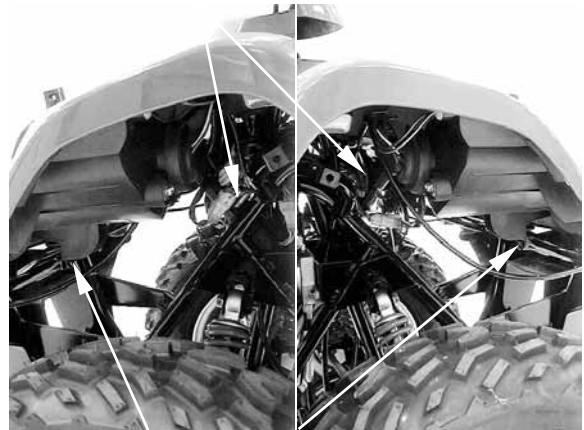

Bolt

Bolt

Remove the four mounting bolts from the front carrier right/left side, then remove the front carrier.

Installation is in the reverse order of removal.



Mounting Bolts

2. FRAME COVERS/EXHAUST MUFFLER

REAR CARGO RACK REMOVAL/INSTALLATION

Remove the two bolts under the rear fender.



Bolt

Remove the four mounting bolts from the rear cargo rack right/left side under the rear fender.

Installation is in the reverse order of removal.

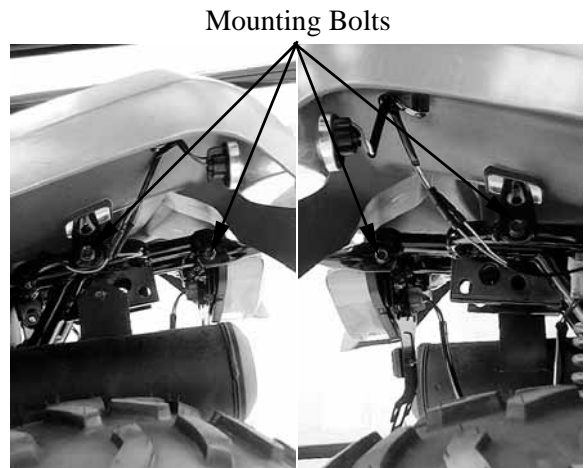

Mounting Bolts

RIGHT/LEFT FOOTBOARD REMOVAL/INSTALLATION

Remove 9 fasteners, 4 mounting bolts and the left footboard.

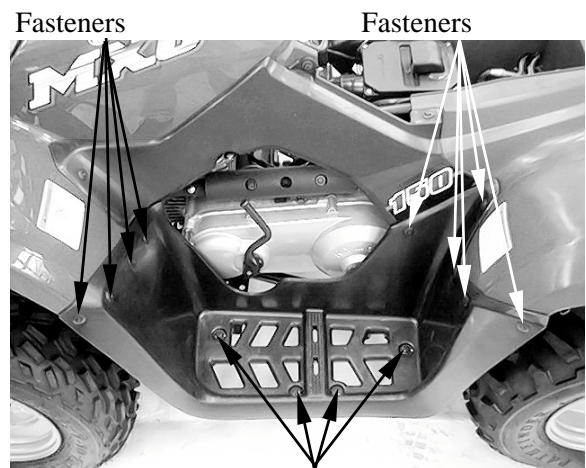

Fasteners

Fasteners

Mounting Bolts

2. FRAME COVERS/EXHAUST MUFFLER

Remove 9 fasteners, 4 mounting bolts and the right footboard.

* During removal, do not pull the joint claws forcedly to avoid damage.

Installation is in the reverse order of removal.

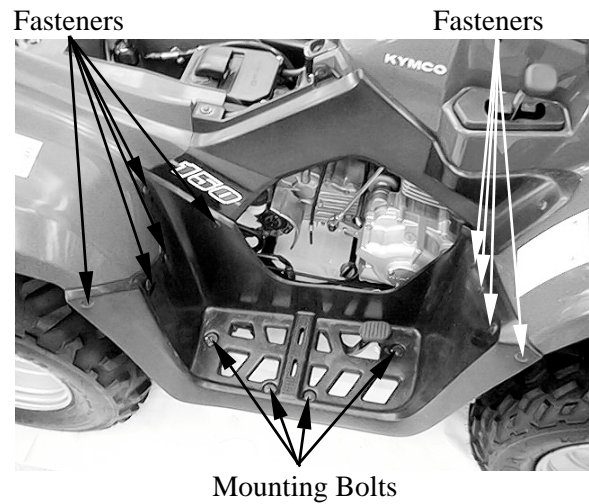

RIGHT/LEFT SIDE COVER REMOVAL/INSTALLATION

Open the seat (see page 2-8).

Remove the right/left footboard (see page 2-10).

Remove the screw, mounting bolt, fastener and right side cover.

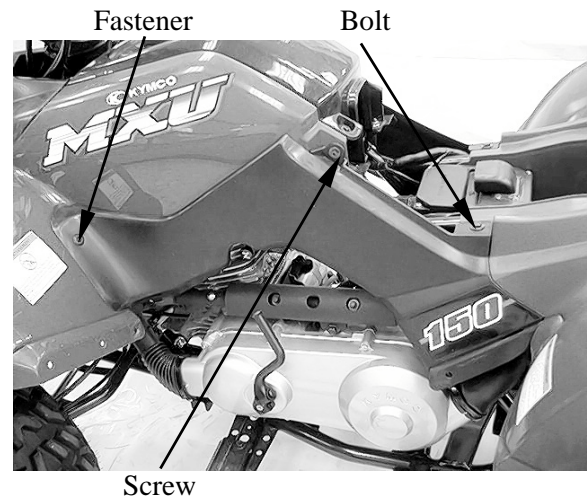

Remove the screw, mounting bolts, fastener and left side cover.

* During removal, do not pull the joint claws forcedly to avoid damage.

Installation is in the reverse order of removal.

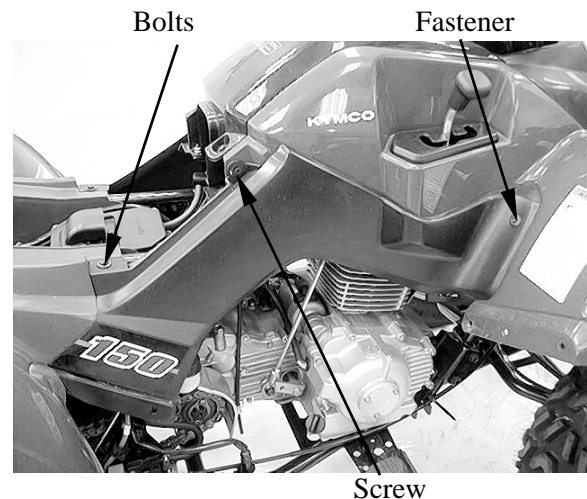

2. FRAME COVERS/EXHAUST MUFFLER

FRONT CENTER COVER REMOVAL/INSTALLATION

Remove the front cargo rack (see page 2-8).

Remove the two screws on the front cover, two screws under the front cover and front center cover.

* During removal, do not pull the joint claws forcibly to avoid damage.

Installation is in the reverse order of removal.

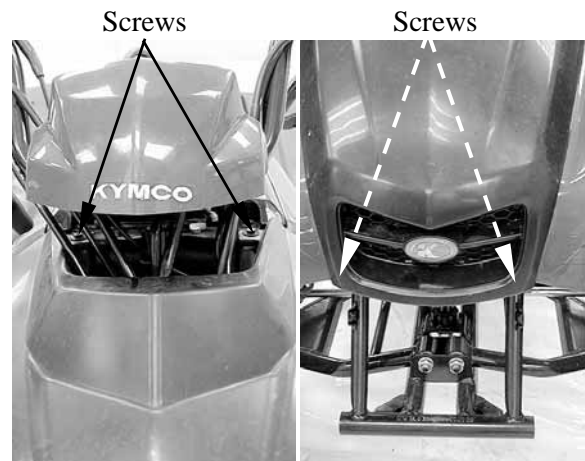

HANDLEBAR COVER REMOVAL/INSTALLATION

Remove the front center cover (see page 2-12).

Disconnect the fuel tank breather hose from the handlebar cover.

Remove the two screws and raise the handlebar cover.

Disconnect the instrument connector

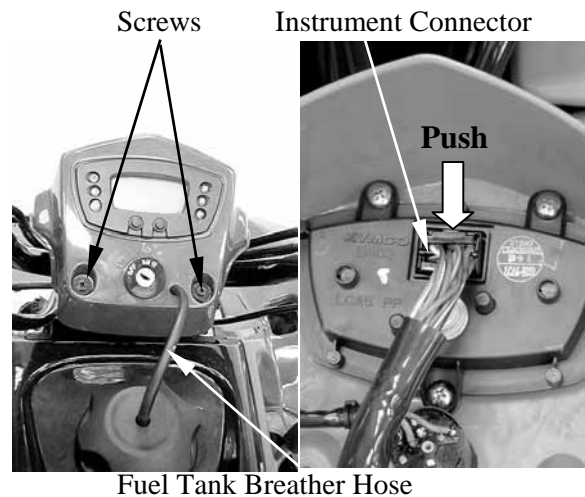

Disconnect the ignition switch connectors, then remove the handlebar cover and instrument.

Installation is in the reserve order of removal.

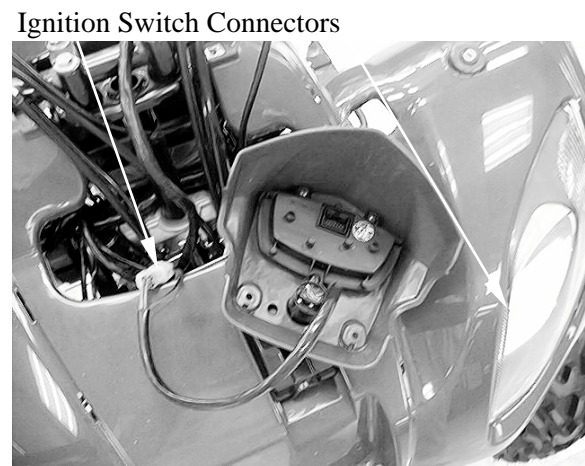

2. FRAME COVERS/EXHAUST MUFFLER

FUEL TANK COVER

REMOVAL/INSTALLATION

Remove the front center cover (see page 2-12).

Remove the four screws and two nuts from the fuel tank cover.

Remove the fuel tank cap by turning it counterclockwise and fuel tank seal, then remove the fuel tank cover.

* Put on the fuel tank cap after removing the cover to prevent duct, mud, etc. from entering the fuel tank

Installation is in the reverse order of removal.

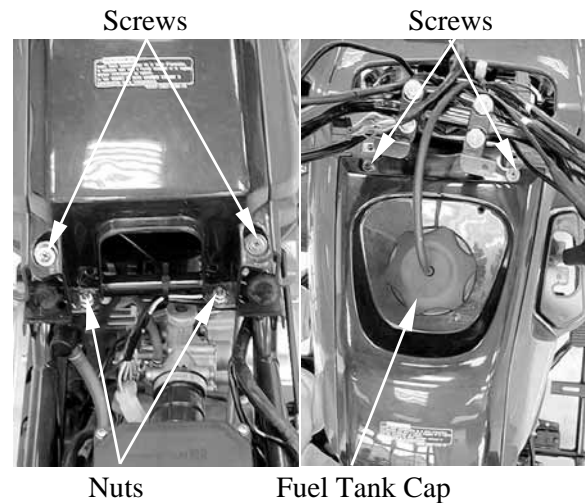

FRONT FENDER

REMOVAL/INSTALLATION

Remove front carrier (see page 2-9), front center cover (see page 2-12), fuel tank cover (see page 2-13) and right/left side cover (see page 2-11).

Disconnect the right and left headlight connectors.

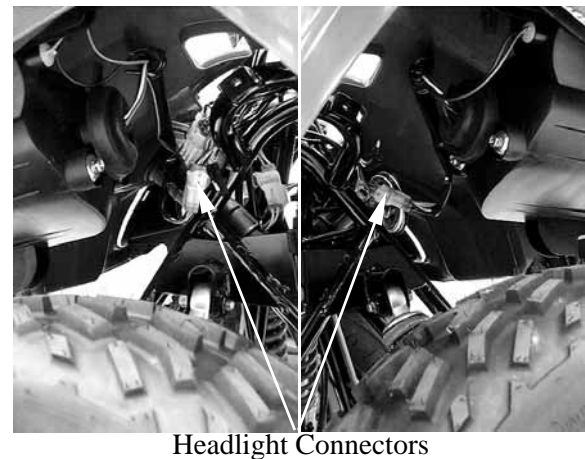

Remove the screw and air filter cover.
Disconnect the air inlet hose from the front fender.
Remove the bolt and drive select lever grip.
Remove the nut, then remove the front fender

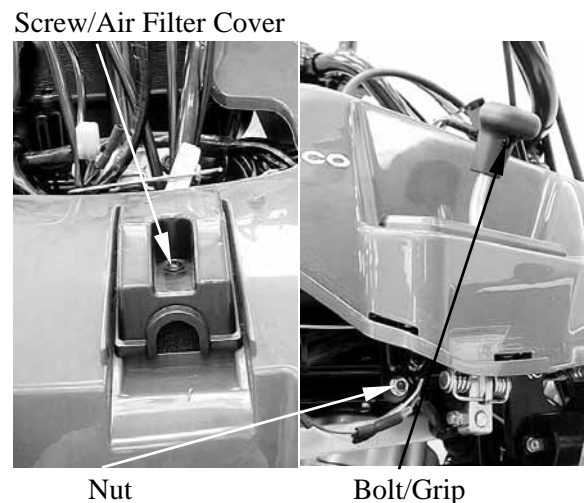

2. FRAME COVERS/EXHAUST MUFFLER

REAR FENDER

REMOVAL/INSTALLATION

Remove rear cargo rack (see page 2-10), battery (see chapter 16) and right/left side cover.

Disconnect the right and left turn signal light connectors.



Right/Left Turn signal Light Connectors

Remove the fuse box.

Disconnect the change gear control unit, CDI connectors and remove them.

Disconnect the starter relay connector.

Slide the rubber sleeve back to expose the nuts, then remove the two nuts and starter relay.

Fuse Box Starter Relay

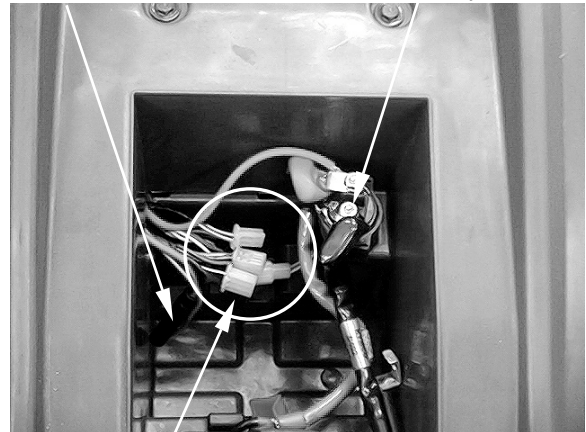

Change Gear Control Unit/CDI Connectors

Loosen the band screw on the air cleaner tube.

Remove the two bolts from the air cleaner, then remove the cleaner.

Bolts

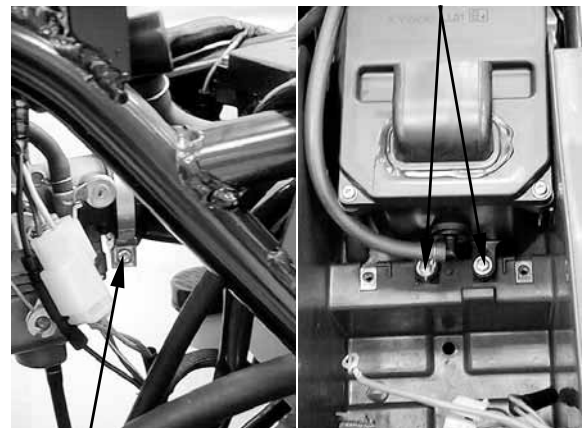

Band Screw

2. FRAME COVERS/EXHAUST MUFFLER

Remove the three bolts, then remove the rear fender.

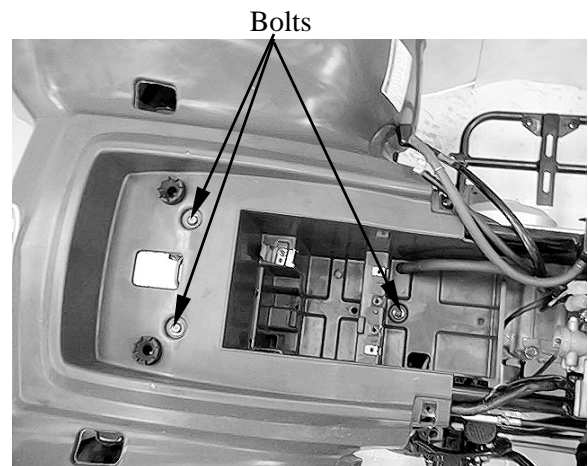

2. FRAME COVERS/EXHAUST MUFFLER

EXHAUST MUFFLER REMOVAL/INSTALLATION

Remove the exhaust pipe joint nuts.

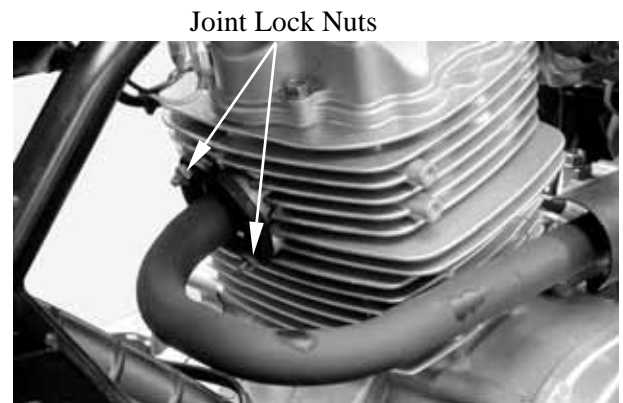

Remove the muffler mounting bolts and exhaust muffler.

Inspect the gasket.

If the exhaust gas leaks, the gasket should be replaced.

Installation is in the reverse order of removal.

Torque:

Exhaust muffler lock bolt:
3.5 kgf-m (35 Nm, 25 lbf-ft)

Exhaust muffler lock nut:
1 kgf-m (10 Nm, 7.2 lbf-ft)

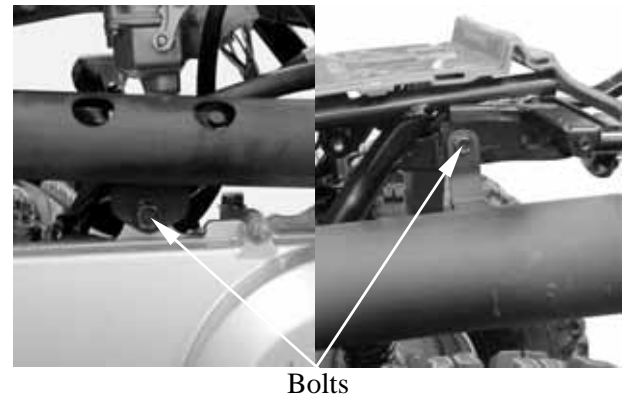

* Be sure to install a new exhaust gasket.

3. INSPECTION/ADJUSTMENT

MAINTENANCE SCHEDULE

This chapter includes all information necessary to perform recommended inspections and adjustments. These preventive maintenance procedures, if followed, will ensure more reliable vehicle operation and a longer service life. The need for costly overhaul work will be greatly reduced. This information applies to vehicles already in service as well as new vehicles that are being prepared for sale. All service technicians should be familiar with this entire chapter.

ITEM	WHICHEVER COMES FIRST ROUTINE	INITIAL		EVERY	
		mi	100	600	1200
		Km	150	1000	2000
		MONTH	1	6	12
Engine oil	•Replace (Warm engine before draining).		○	○	○
Oil strainer	•Clean. •Replace if necessary.		○	○	○
Transmission oil	•Check oil level/oil leakage •Replace every 12 months.		○		○
V-belt	•Check operation. •Replace if damage or excessive wear.		○		○
Air filter element (for engine and *V-belt compartment)	•Clean. •Replace if necessary.	Every 20~40 hours (150~300km, 100~200mi) (More often in wet or dusty areas.)			
Carburetor	•Check idle speed/starter operation. •Adjust if necessary.		○	○	○
Cylinder head cover breather system	•Check breather hose for cracks or damage. •Replace if necessary.			○	○
Spark plug	•Check condition. •Adjust gap and clean. •Replace if necessary.		○	○	○
Fuel line	•Check fuel hose for cracks or damage. •Replace if necessary.			○	○
Valves	•Check valve clearance. •Adjust if necessary.		○	○	○
Brake	•Check operation and brake fluid. •Replace brake pad if necessary.		○	○	○
Coolant	•Check coolant leakage. •Replace if necessary. •Replace coolant every 24 months.		○	○	○
Battery	•Check specific gravity. •Check breather hose for proper operation. •Correct if necessary.		○	○	○
Exhaust system	•Check leakage. •Retighten if necessary. •Replace gasket if necessary.			○	○
Drive chain	•Check and adjust slack/alignment/clean/lube.		○	○	○
Wheels	•Check balance/damage/runout. •Replace if necessary.		○	○	○
Wheel bearings	•Check bearing assembly for looseness/damage. •Replace if damaged.		○	○	○
Steering system	•Check operation. •Replace if damaged. •Check toe-in. •Adjust if necessary.		○	○	○
Knuckle shafts/ Steering shaft	•Lubricate every 6 months.			○	○
Fittings and Fasteners	•Check all chassis fittings and fasteners. •Correct if necessary.		○	○	○
Spark arrester (OFF ROAD)	•Clean			○	○

•In the interest of safety, we recommend these items should be serviced only by an authorized KYMCO motorcycle dealer.

3. INSPECTION/ADJUSTMENT

FUEL LINE

Remove the met-in box.
Check the fuel tubes and replace any parts, which show signs of deterioration, damage or leakage.

* Do not smoke or allow flames or sparks in your working area.

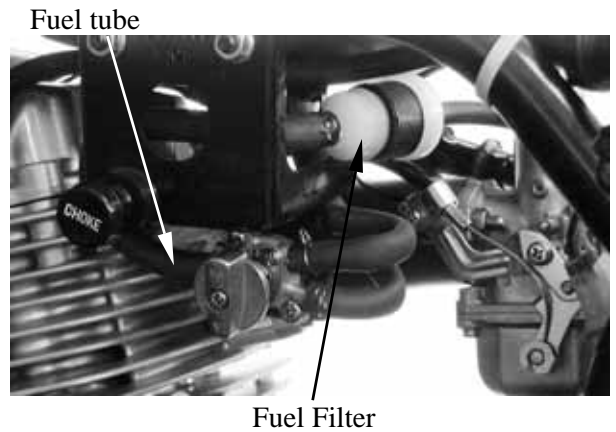

THROTTLE OPERATION

Check the throttle to swing for smooth movement.
Measure the throttle to swing free play.
Free Play: 1~4 mm (0.04~0.16 in)



Minor adjustment is made with the adjusting nut at the throttle to swing above. Slide the rubber cover out and adjust by loosening the lock nut and turning the adjusting nut.

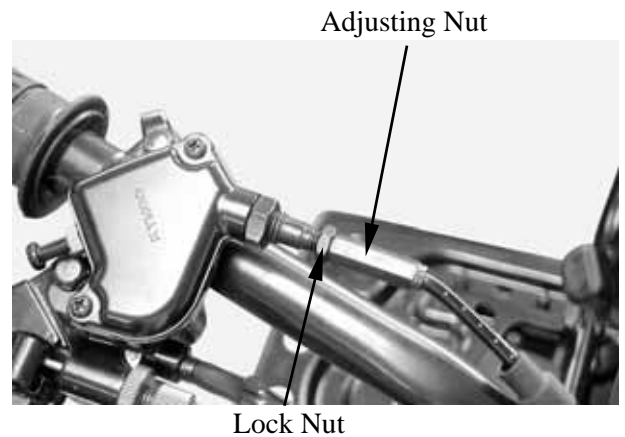

AIR CLEANER

AIR CLEANER REPLACEMENT

Remove the rear side covers.
Remove four screws on the air cleaner case cover and the cover.
Check the element and replace it if it is excessively dirty or damaged.

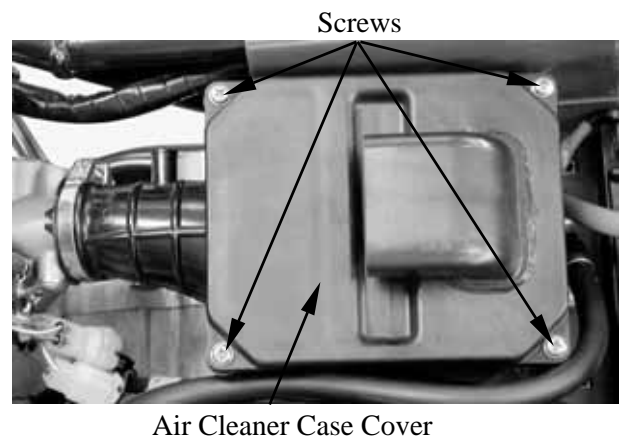

3. INSPECTION/ADJUSTMENT

CLEAN AIR FILTER ELEMENT

Wash the element gently, but thoroughly in solvent.

- * Use parts cleaning solvent only. Never use gasoline or low flash point solvents which may lead to a fire or explosion.

Squeeze the excess solvent out of the element and let dry.

- * Do not twist or wring out the foam element. This could damage the foam material.

Apply the engine oil.

Squeeze out the excess oil.

- * The element should be wet but not dripping.

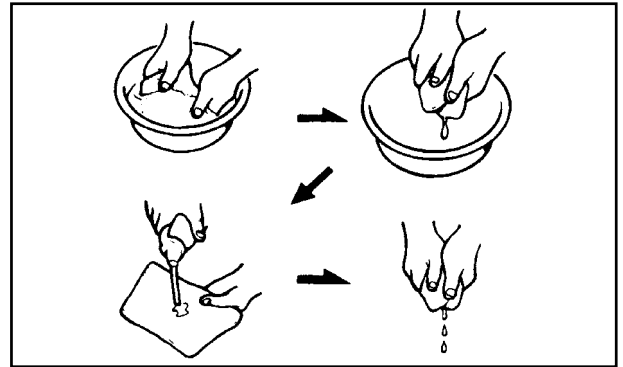

CHANGE INTERVAL

More frequent replacement is required when riding in unusually dusty or rainy areas.

Air Cleaner Element

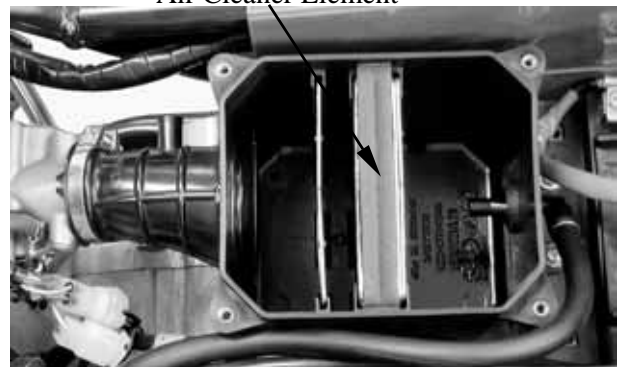

AIR FILTER FOR DRIVE BELT

Remove the front cover.

Remove the screw, air filter case and air filter element.

Inspect the air filter element.

Replace if damage.

Front cover

Air Filter Case

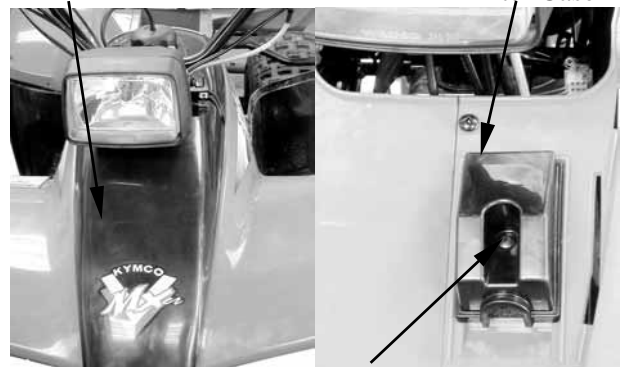

Screw

3. INSPECTION/ADJUSTMENT

Clean air filter element steps:

Tap the element lightly to remove most of the dust and dirt.

Blow out the remaining dirt with compressed air.

Install the air filter element and air filter case.

Install the front cover.

SPARK PLUG

Remove the spark plug.

Check the spark plug for wear and fouling deposits.

Clean any fouling deposits with a spark plug cleaner or a wire brush.

Specified Spark Plug: NGK: CR8E



Measure the spark plug gap.

Spark Plug Gap:

0.6~0.7 mm (0.0024~0.0028 in)

* When installing, first screw in the spark plug by hand and then tighten it with a spark plug wrench.

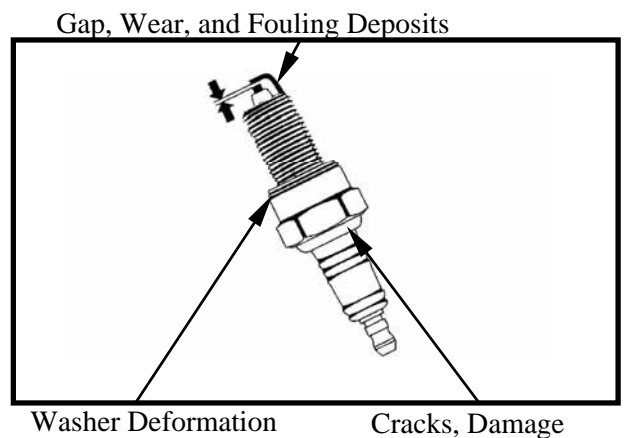

3. INSPECTION/ADJUSTMENT

VALVE CLEARANCE

- * Inspect and adjust valve clearance while the engine is cold (below 35°C).

Remove the cylinder head cover.

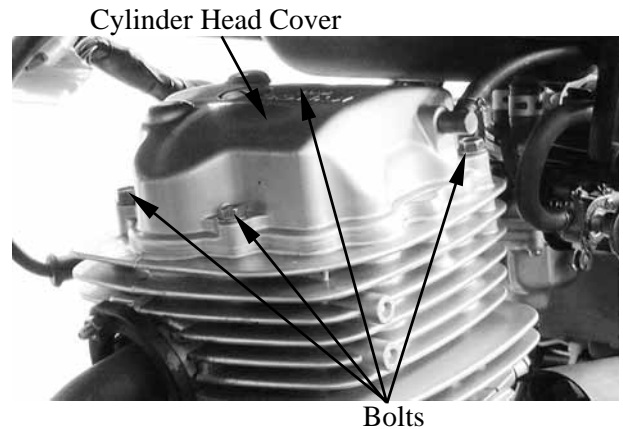

Turn the flywheel counterclockwise so that the “T” mark on the flywheel aligns with the index mark on the crankcase to bring the round hole on the camshaft gear facing up to the top dead center on the compression stroke.

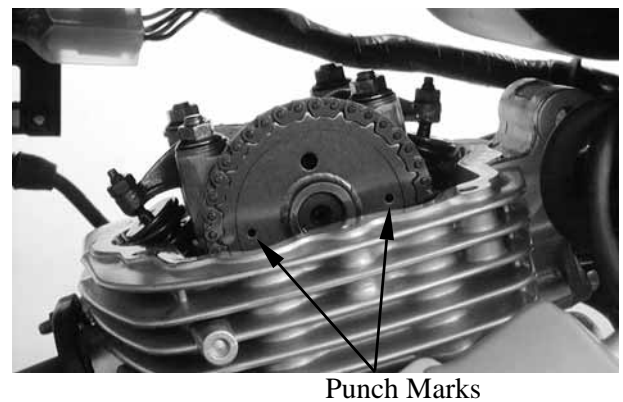

Inspect and adjust the valve clearance.

Valve Clearance: IN: 0.06 mm (0.0024 in)
 EX: 0.06 mm (0.0024 in)

Loosen the lock nut and adjust by turning the adjusting nut

Special tool:

Tappet adjuster E012

- * Check the valve clearance again after the lock nut is tightened.

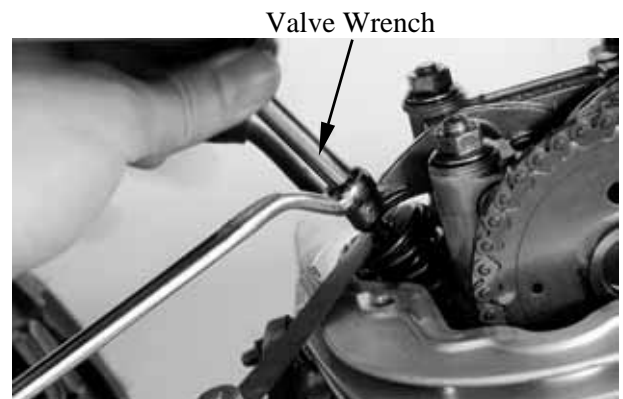

CARBURETOR IDLE SPEED

- * The engine must be warm for accurate idle speed inspection and adjustment.

Warm up the engine before this operation. Start the engine and connect a tachometer. Turn the throttle stop screw to obtain the specified idle speed.

Idle Speed: 1700±100rpm

When the engine misses or run erratic, adjust the air screw.



3. INSPECTION/ADJUSTMENT

IGNITION TIMING

* The CDI unit is not adjustable. If the ignition timing is incorrect, check the ignition system.

Remove the timing hole cap.



Check the ignition timing with a timing light.

When the engine is running at idle speed, the ignition timing is correct if the "F" mark on the flywheel aligns with the index mark on the crankcase.



CYLINDER COMPRESSION

Warm up the engine before compression test.

Remove the spark plug.

Insert a compression gauge.

Open the throttle valve fully and push the starter button to test the compression.

Compression:

1600 kPa (16kg/cm², 227.2 psi)

If the compression is low, check for the following:

- Leaky valves
- Valve clearance too small
- Leaking cylinder head gasket
- Worn piston rings
- Worn piston/cylinder

If the compression is high, it indicates that carbon deposits have accumulated on the combustion chamber and the piston head.

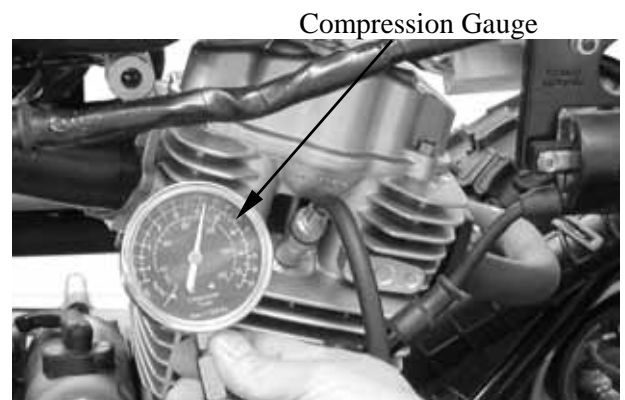

3. INSPECTION/ADJUSTMENT

ENGINE OIL

OIL LEVEL

- * Place the motorcycle upright on level ground for engine oil level check.
- Run the engine for 2~3 minutes and check the oil level after the engine is stopped for 2~3 minutes.

Remove the oil dipstick and check the oil level with the oil dipstick.
 If the level is near the lower level, fill to the upper level with the specified engine oil.

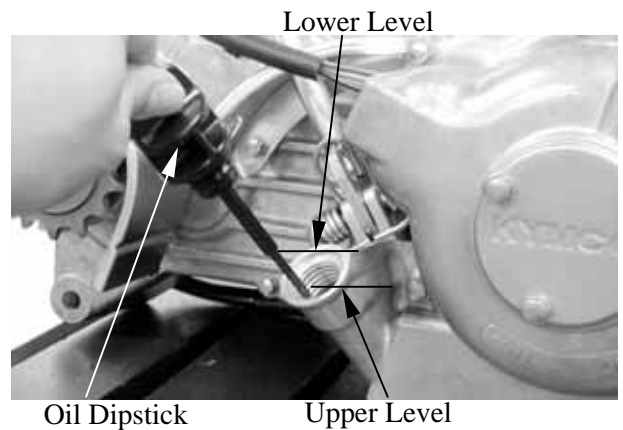

OIL CHANGE

- * The engine oil will drain more easily while the engine is warm.

Remove the oil drain plug bolt located on the bottom of the engine to drain the engine oil thoroughly.
 After the oil has been completely drained, install the oil drain plug bolt.

Torque: 2.5 kgf-m (25 N-m, 18 lbf-ft)

Recommended Oil: SAE30#

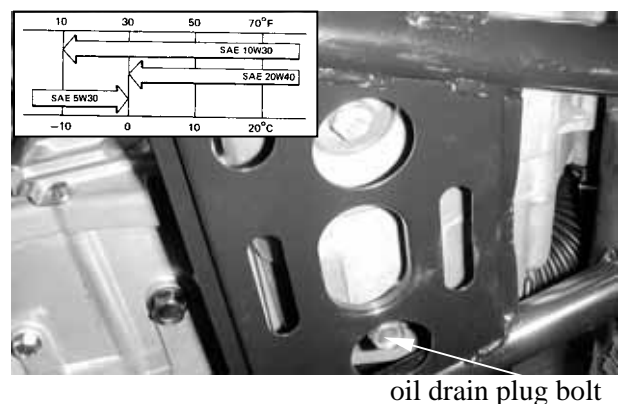

oil drain plug bolt

FINAL REDUCTION GEAR OIL

- * Place the motorcycle on level ground for oil level check.

Recommended Oil: GEAR OIL SAE90#



3. INSPECTION/ADJUSTMENT

GEAR OIL CHANGE

Remove the oil filler bolt.
 Remove the oil drains bolt and drain the oil thoroughly.
 Install the oil drain bolt.
Torque: 1 kgf-m (10 N-m, 7.2 lbf-ft)

* Make sure that the sealing washer is in good condition.

Fill with the recommended oil.

Oil Capacity:

At disassembly:
 400 cc (0.352 Imp qt, 0.424 US qt)

At change:

200 cc (0.176 Imp qt, 0.212 US qt)

Reinstall the oil filler bolt and check for oil leaks.

Torque: 1 kgf-m (10 N-m, 7.2 lbf-ft)

DRIVE BELT

Remove the left crankcase cover.
 Inspect the drive belt for cracks, scaling, chipping or excessive wear.
 Measure the V-belt width

Service limit: 17 mm (0.68 in)

Replace the drive belt if out of specification.



Oil Drain Bolt/ Sealing Washer

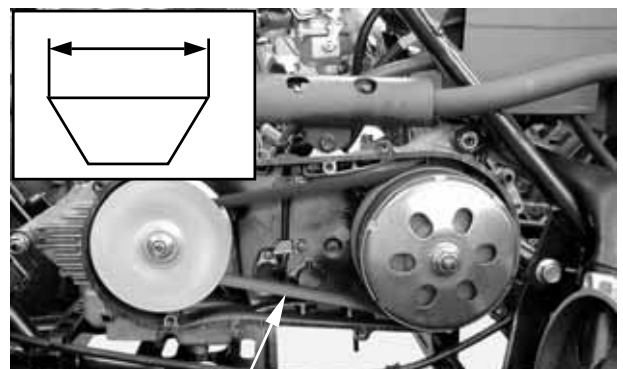

Drive Belt

Wear Indicator

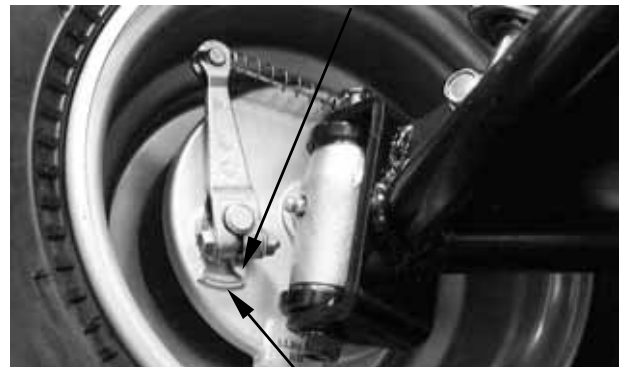

Punch Mark

BRAKE SHOE

Replace the brake shoes if the arrow on the wear indicator plate aligns with the punch mark on the brake panel when the brake is fully applied.

BRAKE SYSTEM

FRONT BRAKE

Measure the front brake lever free play.

Free Play: 10~20 mm (0.4~0.8 in)

Adjust if out of specification.



3. INSPECTION/ADJUSTMENT

Adjust brake lever free play:

Loosen the lock nuts.

Turn the adjusters in or out until the specified free play is obtained.

Turning adjusters in that the free play is increased.

Turning adjusters out that the free play is decreased.

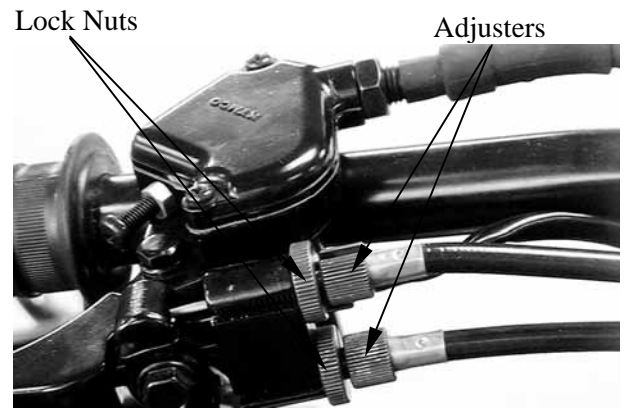

The difference between both clearances should be 2 mm (0.08 in) or less when front brake is applied.

Tighten the lock nuts.

* Make sure that the brake does not drag after adjusting.

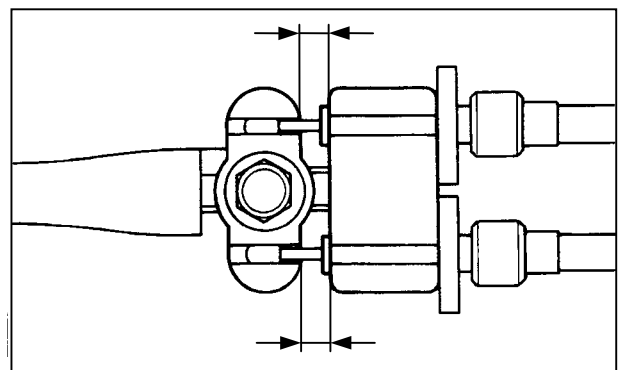

REAR BRAKE

Measure the rear brake lever free play.

Free Play: 10~20 mm (0.4~0.8 in)



If the free play do not fall within the limit, adjust by turning the adjusting nut.

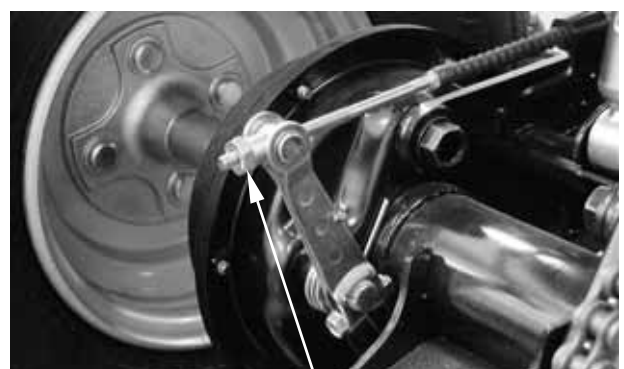

Adjusting Nut

3. INSPECTION/ADJUSTMENT

HEADLIGHT AIM

MX'er 150/125:

Turn the ignition switch ON and start the engine.

Turn on the headlight switch.

Adjust the headlight aim by turning the headlight aim adjusting screw.



Adjusting Screw

MXU 150:

Turn the ignition switch ON and start the engine.

Turn on the headlight switch.

Adjust the headlight aim by turning the headlight aim adjusting screws.

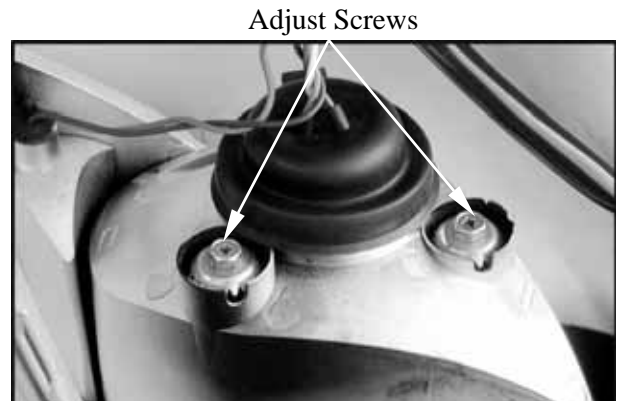

Adjust Screws

3. INSPECTION/ADJUSTMENT

STEERING SYSTEM INSPECTION

Place the machine on a level place.

Check the steering column bushings and bearings:

Move the handlebar up and down, and/or back and forth.

Replace the steering column bushings and or bearings if excessive play



Check the tie-rod ends

Turn the handlebar to the left and/or right until it stops completely, then slightly move the handlebar from left to right.

Replace the tie-rod ends if tie-rod end has any vertical play.



Tie-rod Ends

Raise the front end of the machine so that there is no weight on the front wheels.

Check ball joints and/or wheel bearings.

Move the wheels laterally back and forth.

Replace the front arms and/or wheel bearings if excessive free play.



3. INSPECTION/ADJUSTMENT

TOE-IN ADJUSTMENT

Place the machine on a level place.

Measure the toe-in

Adjust if out of specification.

Toe-in measurement steps:

Mark both front tire tread centers.

Raise the front end of the machine so that there is no weight on the front tires.

Fix the handlebar straight ahead.

Measure the width A between the marks.

Rotate the front tires 180 degrees until the marks come exactly opposite.

Measure the width B between the marks.

Calculate the toe-in using the formula given below.

Toe-in = $B - A$

Toe-in: 0~15 mm (0~0.6 in)

If the toe-in is incorrect, adjust the toe-in

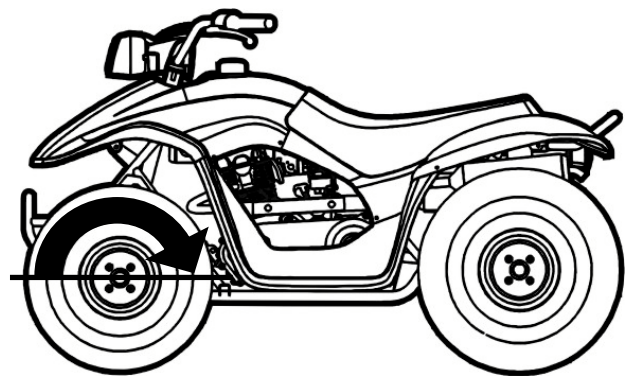
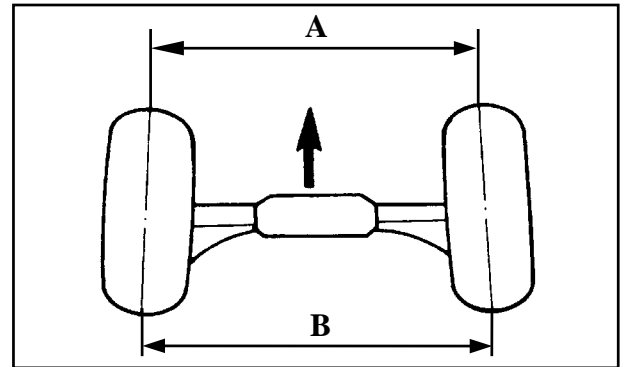

Adjust the toe-in step:

Mark both tie-rod ends.

This reference point will be needed during adjustment.

Loosen the lock nuts (tie-rod end) of both tie-rods

The same number of turns should be given to both tie-rods right and left until the specified toe-in is obtained, so that the lengths of the rods will be kept the same.

Torque: 3 kgf-m (30 N-m, 22 lbf-ft)

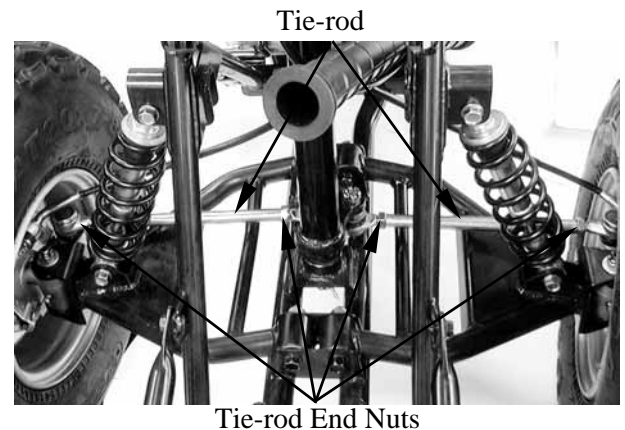

- *
- Be sure that both tie-rod are turned the same amount. If not, the machine will drift tight or left even though the handlebar is positioned straight which may lead to mishandling and accident.
 - After setting the toe-in to specification, run the machine slowly for some distance with hands placed lightly on the handlebar and check that the handlebar responds correctly. If not, turn either the right or left tie-rod within the toe-in specification.

3. INSPECTION/ADJUSTMENT

WHEELS/TIRES

Check the tires for cuts, imbedded nails or other damages.
Check the tire pressure.

* Tire pressure should be checked when tires are cold.

TIRE PRESSURE

	1 Rider	
	MXU 150	MX'er 150/125
Front	28 kPa (0.28 kgf/cm ² , 3.96 psi)	20 kPa (0.2 kgf/cm ² , 2.84 psi)
Rear	28 kPa (0.28 kgf/cm ² , 3.96 psi)	25 kPa (0.25 kgf/cm ² , 3.55 psi)

TIRE SIZE

MX'er 150/125:

Front : 20*7-8

Rear : 22*10-8

MXU 150:

Front : 21*7-10

Rear : 22*10-10

Check the front axle nut for looseness.
Check the rear axle nut for looseness.
If the axle nuts are loose, tighten them to the specified torque.

Torque:

Front: 7 kgf-m (70 N-m, 50 lbt-ft)

Rear : 7 kgf-m (70 N-m, 50 lbt-ft)

WHEEL INSPECTION

Inspect the tire surfaces.
Replace if wear or damage.

Tire wear limit: 3 mm (0.12 in)

* It is dangerous to ride with a worn out tire. When a tire wear is out of specification, replace the tire immediately.



Front Axle Nut



Rear Axle Nut

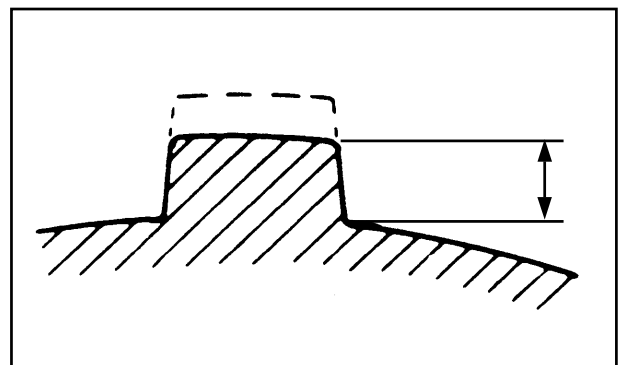

3. INSPECTION/ADJUSTMENT

Inspect the wheel.

Replace if damage or bends

Always balance the wheel when a tire or wheel has been changed or replaced.

*

- Never attempt even small repairs to the wheel.
- Ride conservatively after installing a tire to allow it to seat itself properly on the rim.

DRIVE CHAIN SLACK ADJUSTMENT

Before checking and/or adjusting, rotate the rear wheels several revolutions and check slack at several points to find the tightest point. Check and/or adjust the chain slack with the rear wheels in this “tightest” position.

*
 Too little of chain slack will overload the engine and other vital parts; keep the slack within the specified limits.

Place the machine on a level place.

*
 Wheels should be on the ground without the rider on it.

Check drive chain slack.

Adjust if out of specification.

Drive chain slack:

10~20 mm (0.4~0.8 in)

Adjust drive chain slack:

Elevate the rear wheels by placing a suitable stand under the rear of frame.

*
 Support the machine securely so there is no danger of it falling over.

Loosen four bolts attaching rear axle hub.

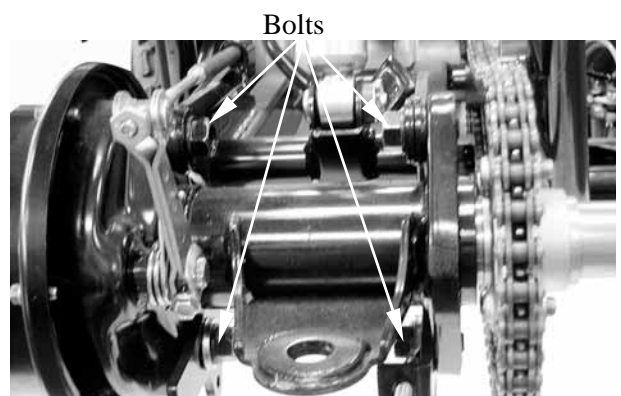

3. INSPECTION/ADJUSTMENT

Turn the adjuster in or out until the specified slack is obtained.

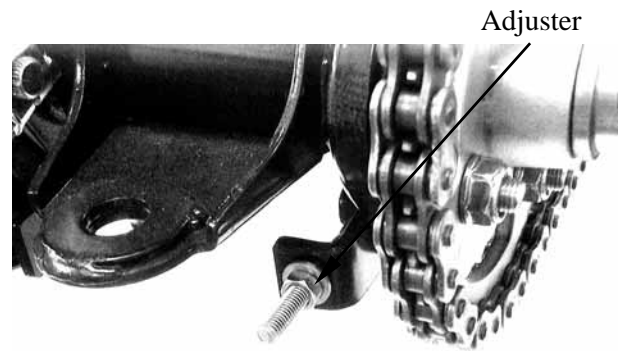

Turn out: Slack is decreased.

Turn in: Slack is increased.



Tighten four bolts attaching rear axle hub to the specification. While pushing up or down on the chain to zero slack.

Torque: 7 kgf-m (70 N-m, 50 lbf-ft)

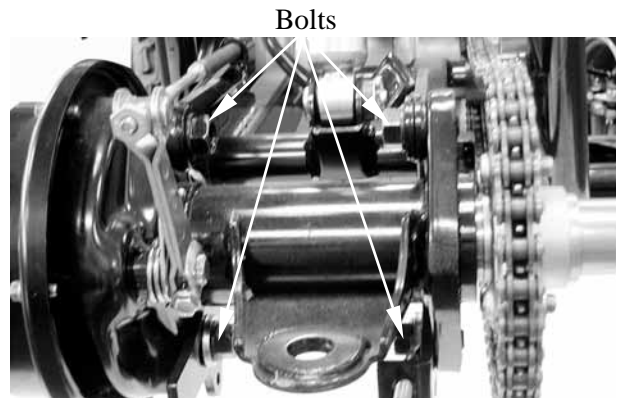

Tighten the adjuster.

Torque: 2.15 kgf-m (21.5 N-m, 15.5 lbf-ft)

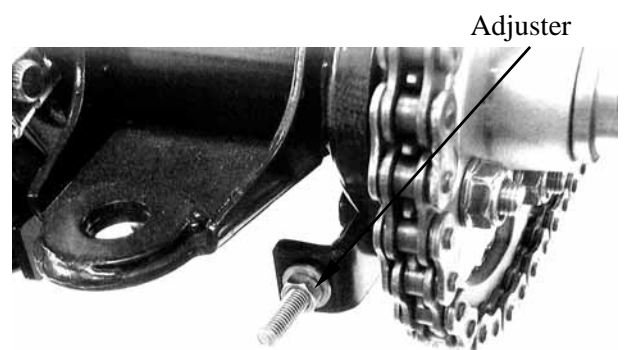

3. INSPECTION/ADJUSTMENT

CABLE INSPECTION AND LUBRICATION

- * Damaged cable sheath may cause corrosion and interfere with the cable movement. An unsafe condition may result so replace such cable as soon as possible.

Inspect the cable sheath.

Replace if damage.

Check the cable operation.

Lubricate or replace if unsmooth operation.

- * Hold cable end high and apply several drops of lubricant to cable.

LEVER LUBRICATION

Lubricate the pivoting parts of each lever.

FRONT SUSPENSION LUBRICATION

Inject grease into the nipples using a grease gun until slight over flow is observed from the thrust covers.

- * Wipe off the excess grease.



Nipple

4. LUBRICATION SYSTEM

4

LUBRICATION SYSTEM

SERVICE INFORMATION-----	4- 2
TROUBLESHOOTING-----	4- 2
ENGINE OIL/OIL FILTER -----	4- 3
OIL PUMP-----	4- 3

4. LUBRICATION SYSTEM

LUBRICATION SYSTEM

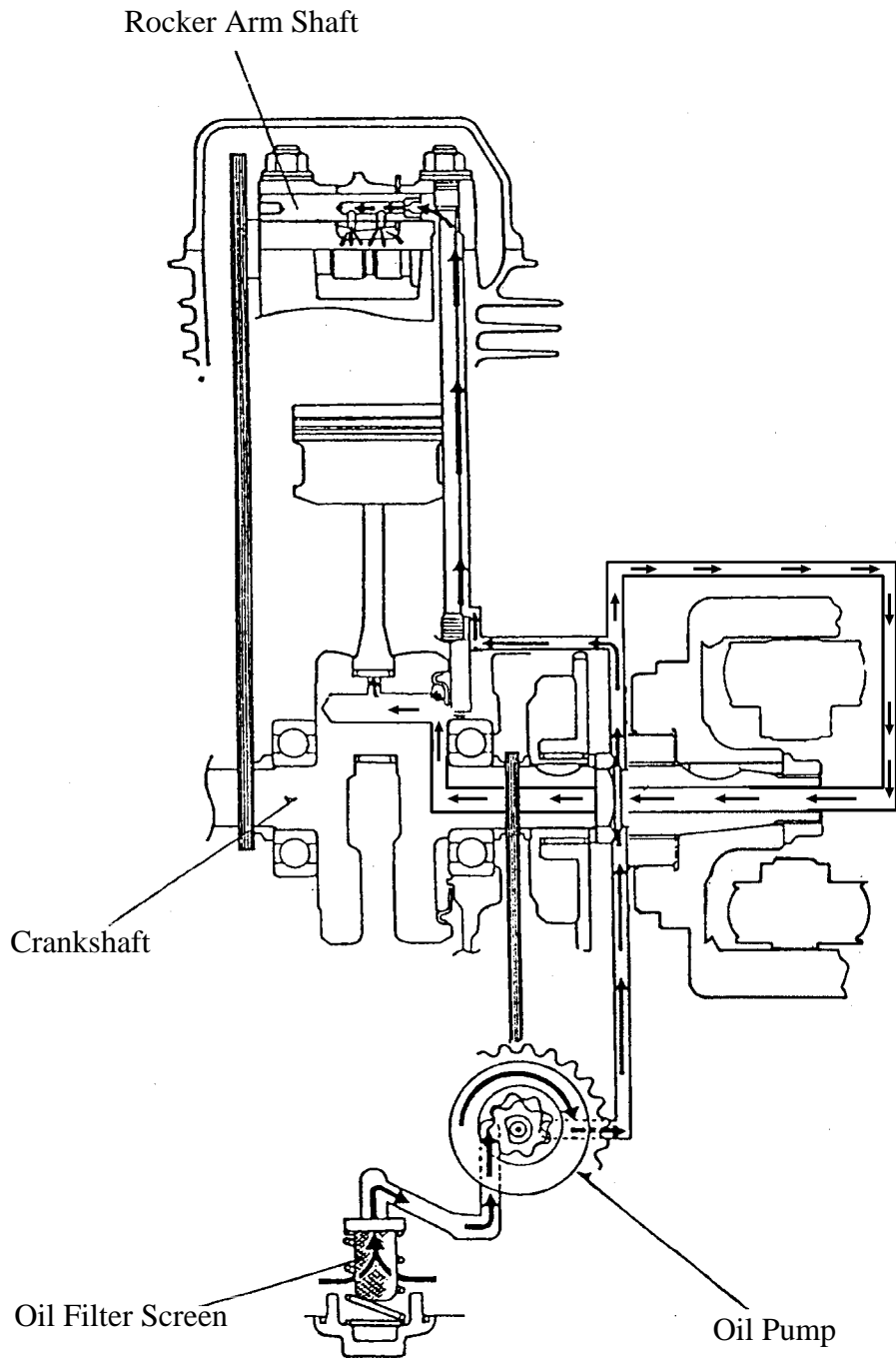

4. LUBRICATION SYSTEM

SERVICE INFORMATION

GENERAL INSTRUCTIONS

- The maintenance of lubrication system can be performed with the engine installed in the frame.
- Use care when removing and installing the oil pump not to allow dust and foreign matters to enter the engine and oil line.
- Do not attempt to disassemble the oil pump. The oil pump must be replaced as a set when it reaches its service limit.
- After the oil pump is installed, check each part for oil leaks.

SPECIFICATIONS

mm (in)

Item		Standard	Service Limit
Oil pump	Inner rotor-to-outer rotor clearance	—	0.12 (0.0048)
	Outer rotor-to-pump body clearance	—	0.12 (0.0048)
	Rotor end-to-pump body clearance	0.05 ~ 0.1 (0.002 ~ 0.004)	0.2 (0.008)

TROUBLESHOOTING

Oil level too low

- Natural oil consumption
- Oil leaks
- Worn or poorly installed piston rings
- Worn valve guide or seal

Poor lubrication pressure

- Oil level too low
- Clogged oil filter or oil passages
- Not use the specified oil

4. LUBRICATION SYSTEM

ENGINE OIL/OIL FILTER

OIL LEVEL

- * Place the motorcycle upright on level ground for engine oil level check.
- Run the engine for 2~3 minutes and check the oil level after the engine is stopped for 2~3 minutes.

Remove the oil dipstick and check the oil level with the oil dipstick.
 If the level is near the lower level, fill to the upper level with the specified engine oil.

OIL CHANGE

- * The engine oil will drain more easily while the engine is warm.

Remove the oil drain plug bolt located on the bottom of the engine to drain the engine oil thoroughly.

After the oil has been completely drained, install the oil drain plug bolt.

Torque: 2.5 kgf-m (25 N-m, 18 lbf-ft)

Refer to page 3-2 to clean the engine oil filter screen

After the oil has been completely drained, check the filter screen O-ring for damage and replace if necessary.

Install the oil filter screen, spring and filter screen cap.

Torque: 1.5 kgf-m (15 N-m, 11 lbf-ft)

Fill with the specified SAE15W40#, API: SG engine oil to the proper level.

Oil Capacity:

At disassembly:

1 liter (0.88 Imp qt, 1.06 US qt)

At change:

0.9 liter (0.79 Imp qt, 0.95 US qt)

Check for oil leaks and then start the engine and let it idle for few minutes.

Recheck the oil level.

OIL PUMP

REMOVAL

Remove the right crankcase cover.

Remove the A.C. generator flywheel.

Special tool:

Flywheel holder E021

Flywheel puller E003

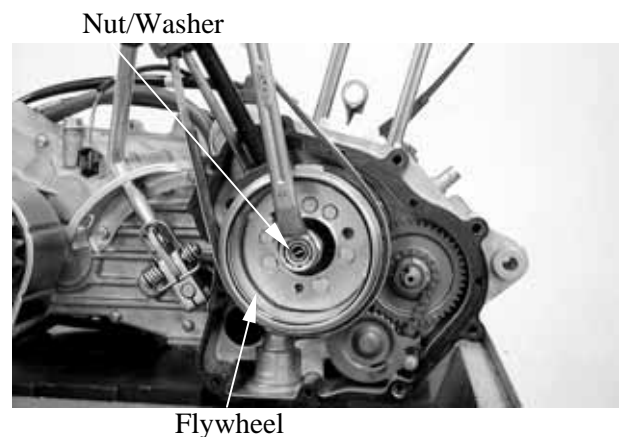
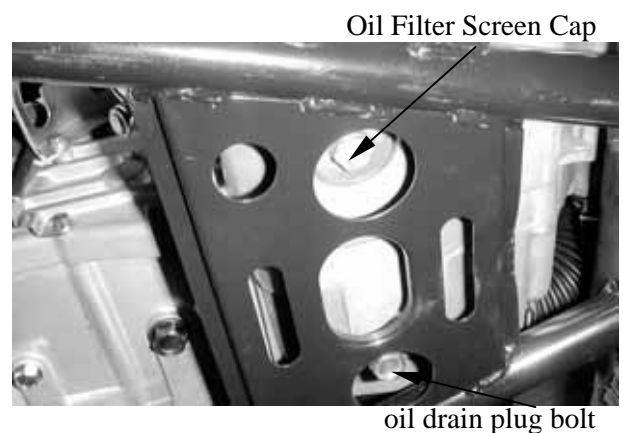
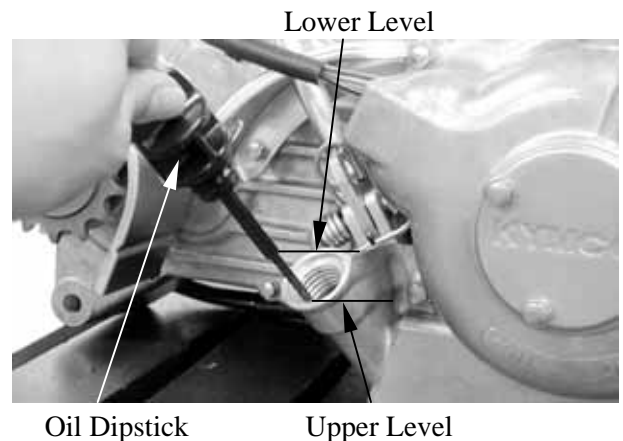

4. LUBRICATION SYSTEM

Remove the nut (**Left threaded**) and washer using the special tool.

Special tool:

Lock nut socket wrench E009

Remove the starter idle gear and starter clutch.

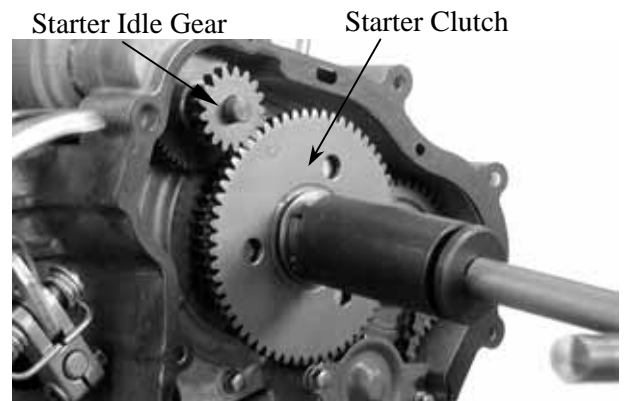

Remove the two bolts and oil separator cover.

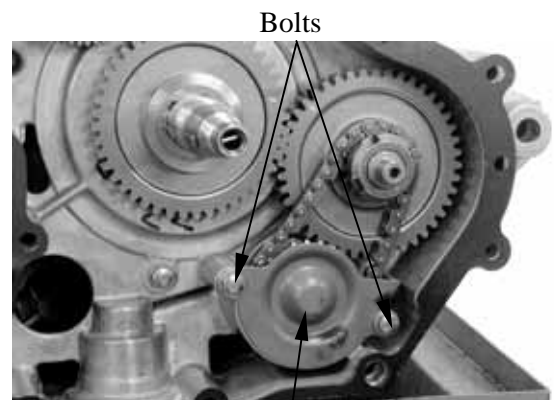

Oil Separator Cover

Remove the oil pump driven gear nut to remove the oil pump driven gear and drive chain.

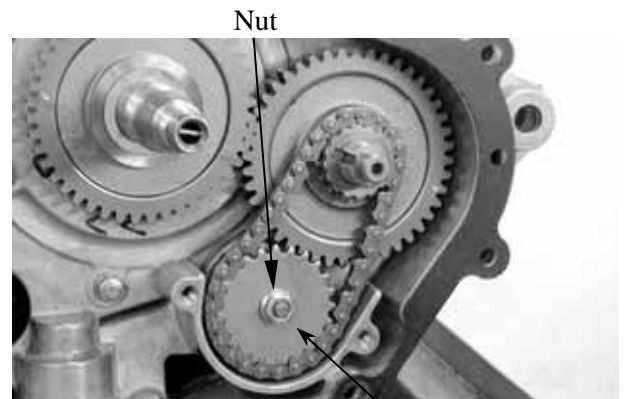

Oil Pump Driven Gear

Remove the oil pump mounting two bolts and the oil pump.

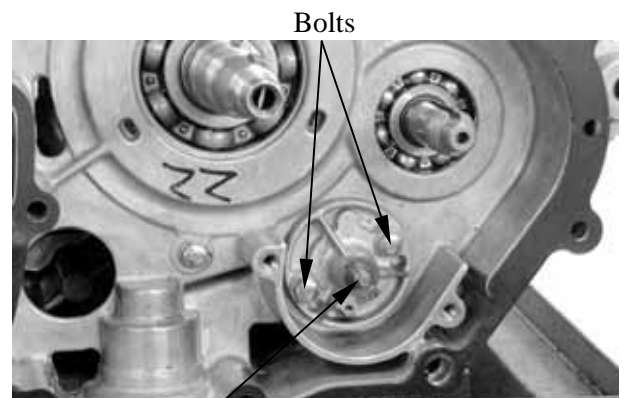

Oil Pump

4. LUBRICATION SYSTEM

DISASSEMBLY

Remove the screw and disassemble the oil pump.

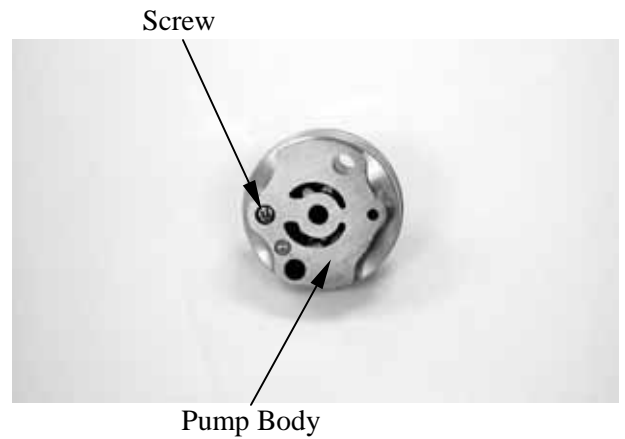

INSPECTION

Measure the pump body-to-outer rotor clearance.

Service Limit: 0.12 mm (0.0048 in)

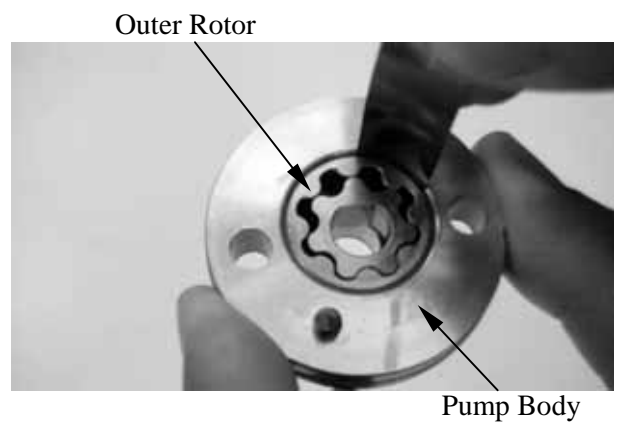

Measure the inner rotor-to-outer rotor clearance.

Service Limit: 0.12 mm (0.0048 in)

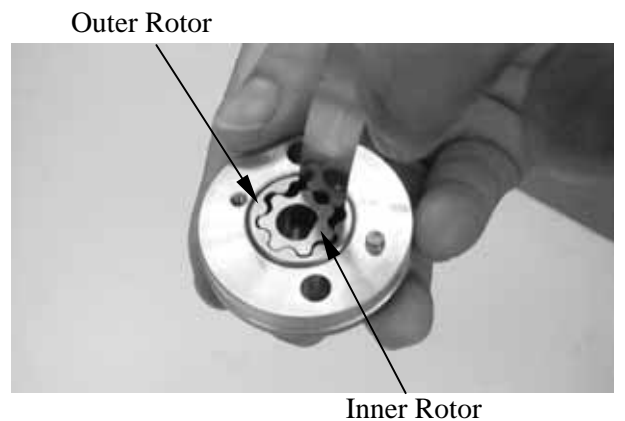

Measure the rotor end-to-pump body clearance.

Service Limit: 0.2 mm (0.008 in)



4. LUBRICATION SYSTEM

ASSEMBLY

Install the outer rotor, inner rotor and pump shaft into the pump body.

- * Insert the pump shaft by aligning the flat on the shaft with the flat in the inner rotor.

Install the dowel pin.
Install the pump cover by aligning the hole in the cover with the dowel pin.

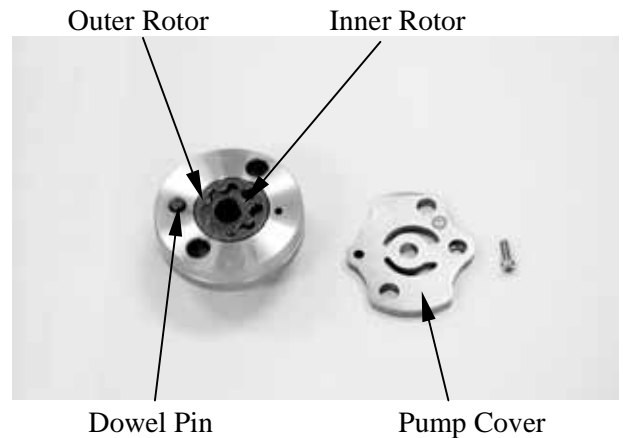

Tighten the screw to secure the pump cover.
Make sure that the pump shaft rotates freely without binding.



INSTALLATION

Install the oil pump into the crankcase.

- * Install the oil pump with the arrow mark on the pump body facing up and fill the oil pump with engine oil before installation.

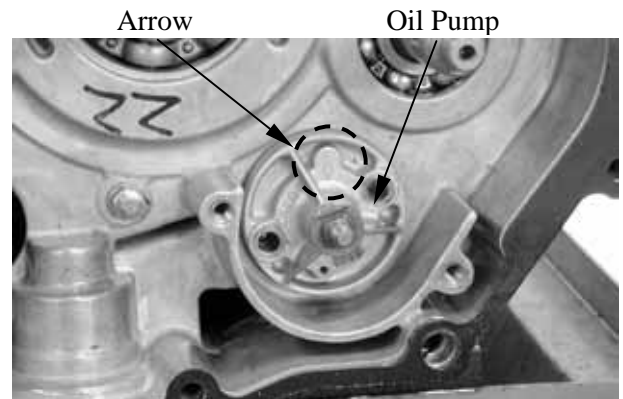

After the oil pump is installed, tighten the two mounting bolts.

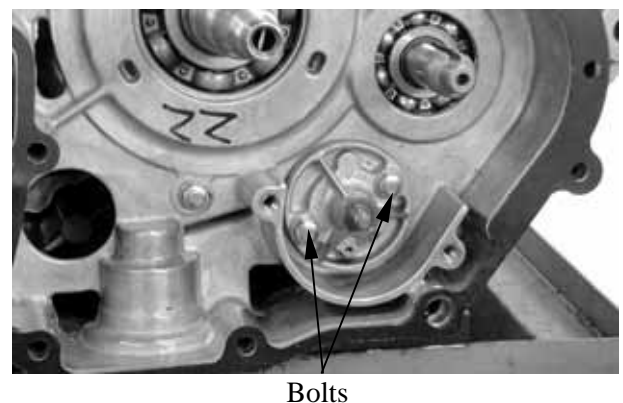

4. LUBRICATION SYSTEM

Install the pump driven gear and drive chain by aligning the pump driven gear with the cutout in the pump shaft.
Install and tighten the pump driven gear nut.

Torque: 1 kgf-m (10 N-m, 7.2 lbf-ft)

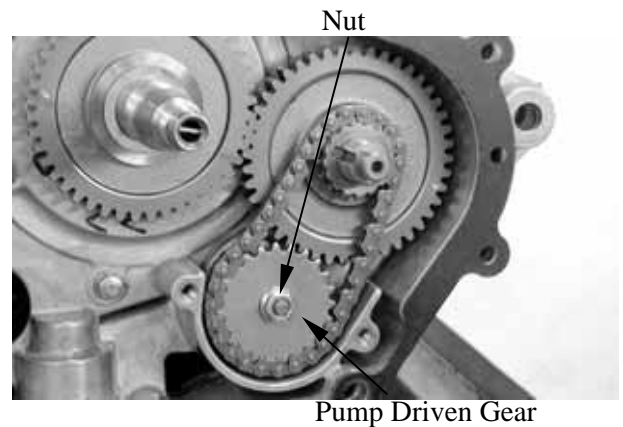

Install the oil separator cover and tighten the bolts.

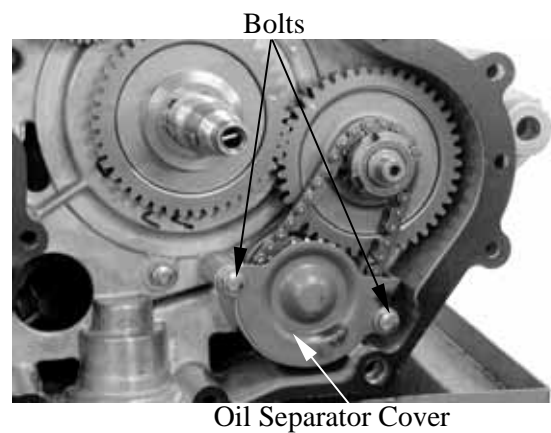

Install the starter idle gear.
Install starter clutch and washer.

* Make sure the "INSIDE" mark on the washer facing the right crankcase.

Install the nut (**Left threaded**) and tighten it using the special tool to specified torque.

Special tool:

Lock nut socket wrench E009

Torque: 9.5 kgf-m (95 N-m, 68 lbf-ft)

Install the gasket and dowel pins.

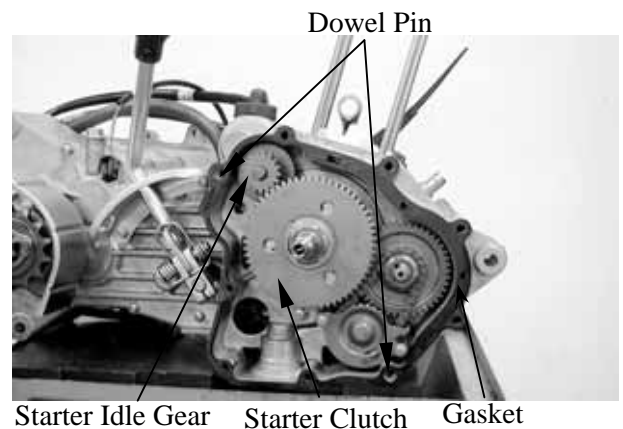

4. LUBRICATION SYSTEM

Install the A.C. generator flywheel, washer and nut, then tighten the nut to specified torque.

Torque: 5.5 kgf-m (55 N-m 40 lbf-ft)

Special tool:

Flywheel holder E021

Install the right crankcase cover.

Torque: 1 kgf-m (10 N-m, 7.2 lbf-ft)

* Diagonally tighten the bolts in 2~3 times.

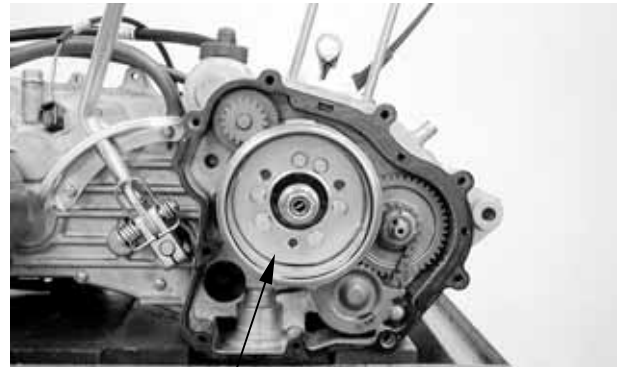

Flywheel

5. FUEL SYSTEM

5

FUEL SYSTEM

SERVICE INFORMATION-----	5- 2
TROUBLESHOOTING-----	5- 3
THROTTLE VALVE DISASSEMBLY/CARBURETOR REMOVAL--	5- 4
FLOAT/FLOAT VALVE/JETS-----	5- 5
CARBURETOR INSTALLATION -----	5- 8
FUEL TANK -----	5- 9
FUEL VALVE REMOVAL -----	5- 9
AIR CLEANER -----	5-10

5. FUEL SYSTEM

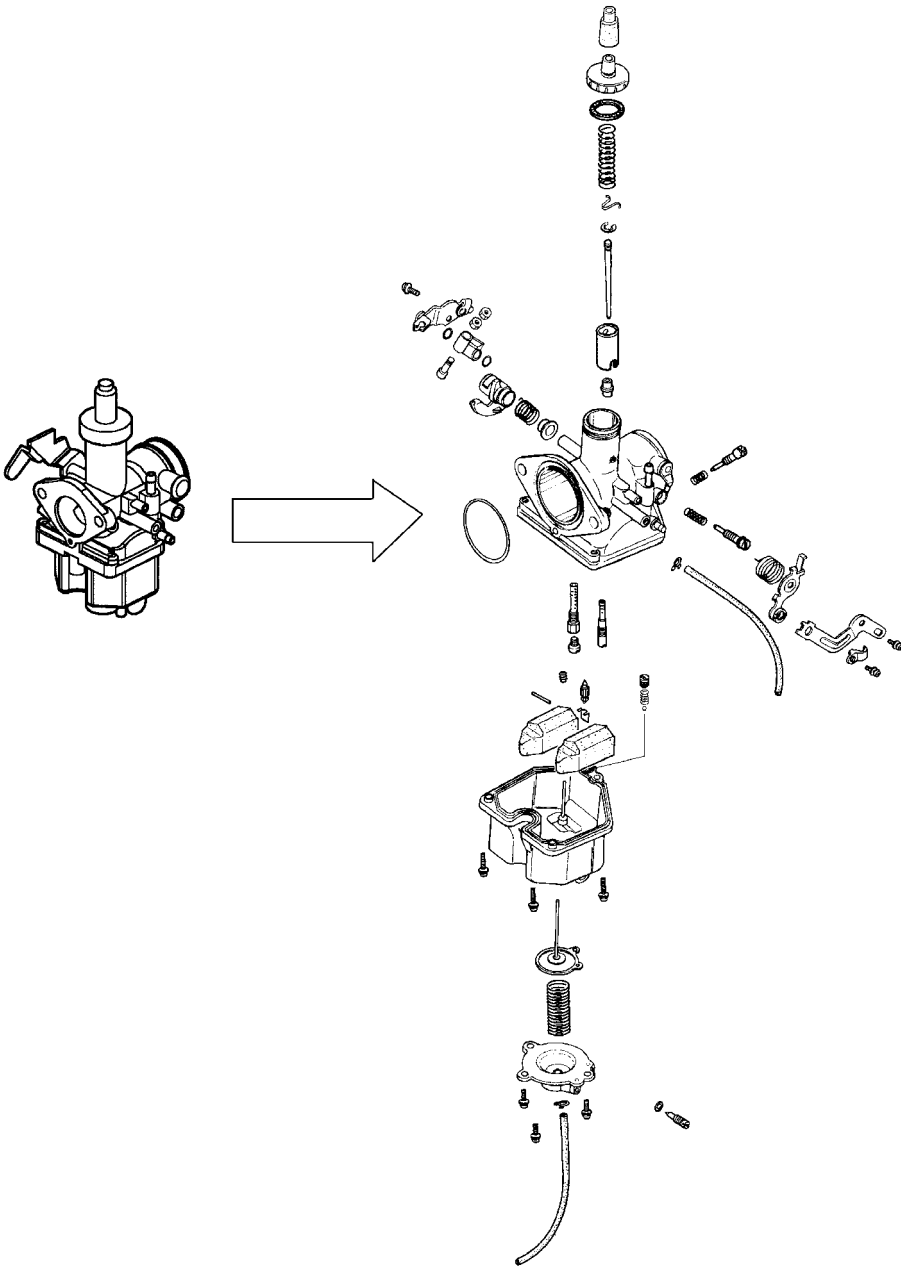

5. FUEL SYSTEM

SERVICE INFORMATION

GENERAL INSTRUCTIONS



Gasoline is very dangerous. When working with gasoline, keep sparks and flames away from the working area.
Gasoline is extremely flammable and is explosive under certain conditions. Be sure to work in a well-ventilated area.

- Do not bend or twist control cables. Damaged control cables will not operate smoothly.
- When disassembling fuel system parts, note the locations of O-rings. Replace them with new ones during reassembly.
- Before float chamber disassembly, loosen the drain screw to drain the residual gasoline into a clean container.
- After the carburetor is removed, plug the intake manifold side with a clean shop towel to prevent foreign matters from entering.
- When cleaning the carburetor air and fuel jets, the O-rings and diaphragm must be removed first to avoid damage. Then, clean with compressed air.
- When the motorcycle is not used for over one month, drain the residual gasoline from the float chamber to avoid erratic idling and clogged slow jet due to deteriorated fuel.

SPECIFICATIONS

	ATV 150	ATV 125
Item	Standard	Standard
Type	PD	PD
Venturi dia.	φ25	φ25
Float level	14.8 mm (0.592 in)	14.8 mm (0.592 in)
Main jet No.	95	95
Adjust method	Piston	Piston
Idle speed	1700±100rpm	1700±100rpm
Throttle grip free play	1 ~ 4 mm (0.04 ~ 0.16 in)	1 ~ 4 mm (0.04 ~ 0.16 in)
Air screw opening	2±1/2	2±1/2

5. FUEL SYSTEM

SPECIAL TOOL

Float level gauge

TROUBLESHOOTING

Engine cranks but won't start

- No fuel in tank
- No fuel to carburetor
- Cylinder flooded with fuel
- No spark at plug
- Clogged air cleaner
- Intake air leak
- Improper throttle operation

Engine idles roughly, stalls or runs poorly

- Excessively used choke
- Ignition malfunction
- Faulty carburetor
- Poor quality fuel
- Lean or rich mixture
- Incorrect idle speed

Misfiring during acceleration

- Faulty ignition system
- Faulty carburetor

Backfiring at deceleration

- Float level too low
- Incorrectly adjusted carburetor
- Faulty exhaust muffler

Engine lacks power

- Clogged air cleaner
- Faulty carburetor
- Faulty ignition system

Lean mixture

- Clogged carburetor fuel jets
- Float level too low
- Intake air leak
- Clogged fuel tank cap breather hole
- Kinked or restricted fuel line

Rich mixture

- Float level too high
- Clogged air jets
- Clogged air cleaner

5. FUEL SYSTEM

THROTTLE VALVE DISASSEMBLY

Remove the front cover.
Remove the front fender.
Remove the carburetor cap.
Pull out the throttle valve.
Disconnect the choke knob cable.

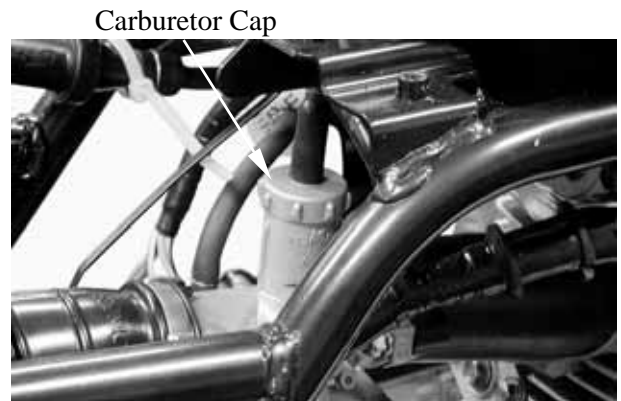

Disconnect the throttle cable and remove the spring from the throttle valve.

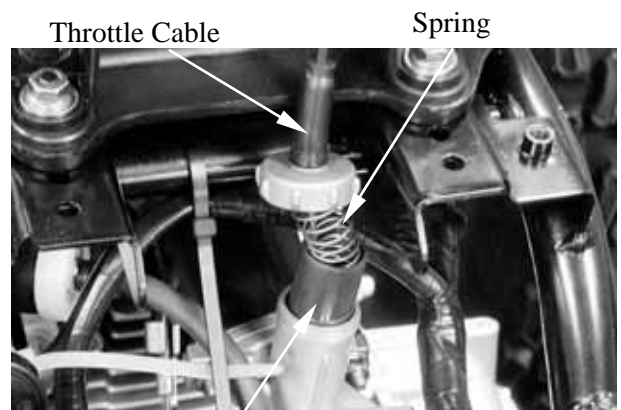

Pry off the needle retainer and remove the jet needle.
Check the throttle valve and jet needle for wear or damage.

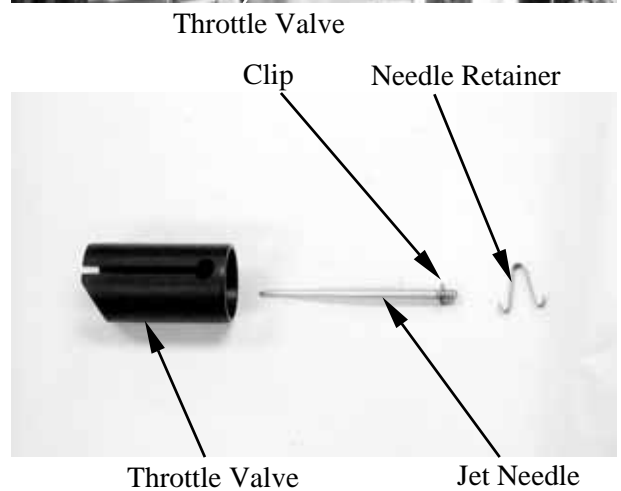

CARBURETOR REMOVAL

Switch the fuel valve OFF.
Loosen the drain screw to drain the gasoline from the float chamber.

- *
 - Keep sparks and flames away from the work area.
 - Drain gasoline into a clean container.

Disconnect the fuel inlet tube and the choke cable.

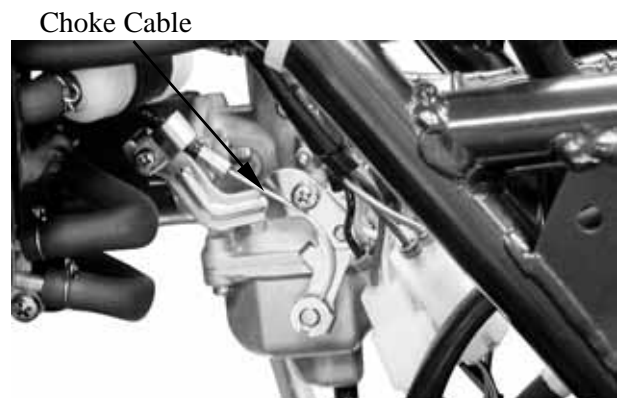

5. FUEL SYSTEM

Loosen the air cleaner connecting tube band screw.
Remove the two carburetor lock nuts.
Remove the carburetor

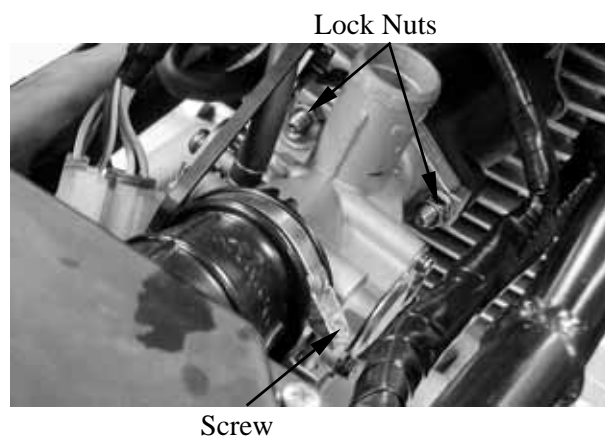

FLOAT/FLOAT VALVE/JETS

FLOAT/FLOAT VALVE DISASSEMBLY

Remove the float chamber attaching three screws and remove the float chamber.

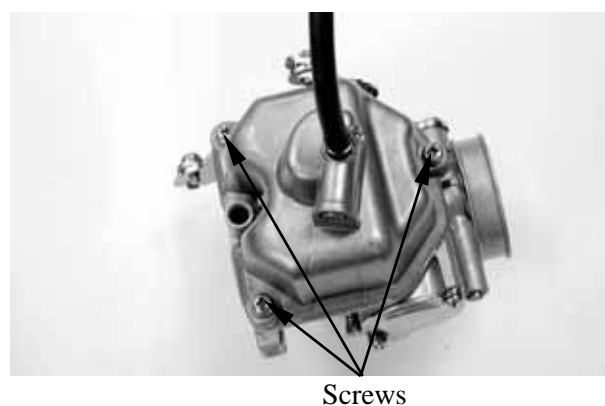

Remove the float pin, float and float valve.

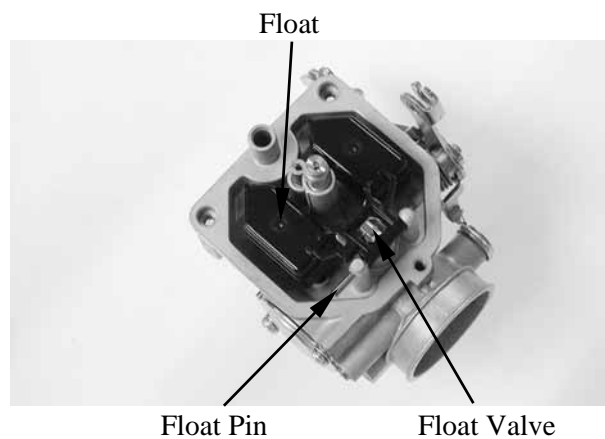

FLOAT/FLOAT VALVE INSPECTION

Inspect the float valve seat for wear or damage.
Inspect the float for damage or fuel level inside the float chamber.

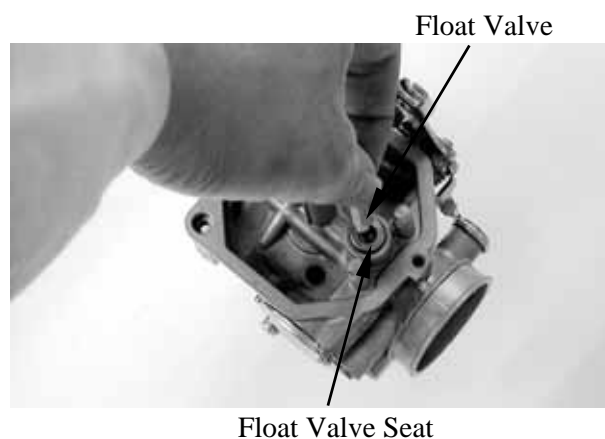

5. FUEL SYSTEM

JETS/AIR SCREW/THROTTLE STOP SCREW REMOVAL

Remove the main jet, needle jet holder, and needle jet.

Remove the slow jet.

Remove the air screw and throttle stop screw.

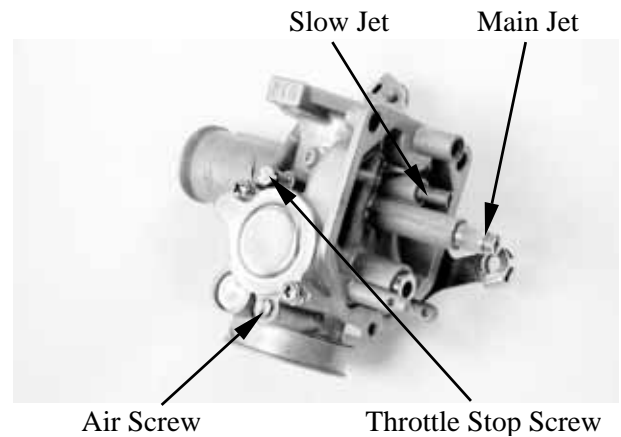

CAUTIONS !

- * • Be careful not to damage the jets and jet holder when removing them.
- Before removal, turn the throttle stop screw and air screw in and count the number of turns until they seat lightly and then make a note of this.
- Do not force the screw against its seat to avoid seat damage.
- Be sure to install the O-ring in the reverse order of removal.

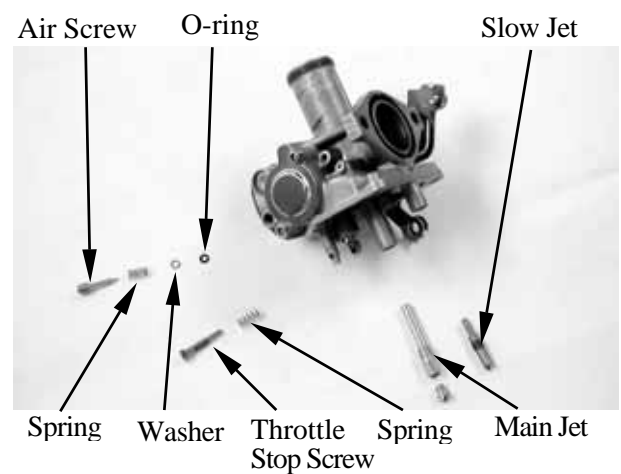

FUEL RESERVOIR O-RING CHECK

Remove the O-ring.

INSPECTION

Inspect the check the O-ring for damage. Replace with new ones if necessary

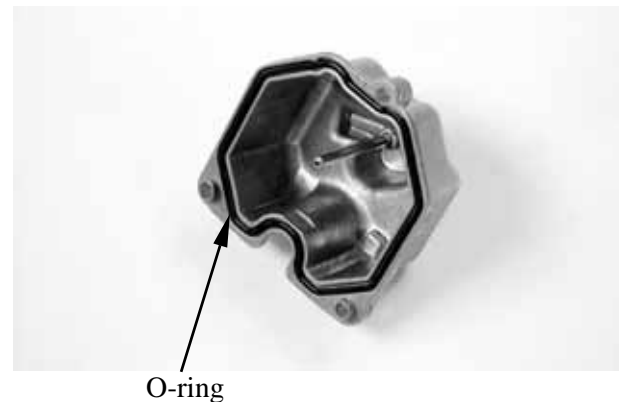

CARBURETOR CLEANING

Blow compressed air through all passages of the carburetor body.



5. FUEL SYSTEM

SLOW/MAIN JET INSTALLATION

Install the slow jet.
Install the needle jet, needle jet holder and main jet.
Install the throttle stop screw and air screw

- * • When installing the air screw, return it to the original position as noted during removal
• After the carburetor is installed, be sure to perform the Exhaust Emission

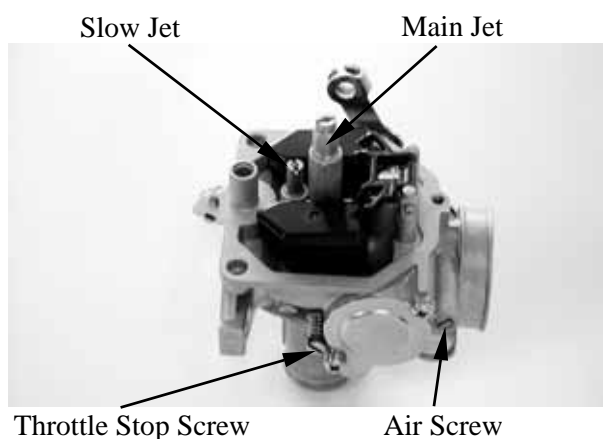

Install the float valve, float and float pin.

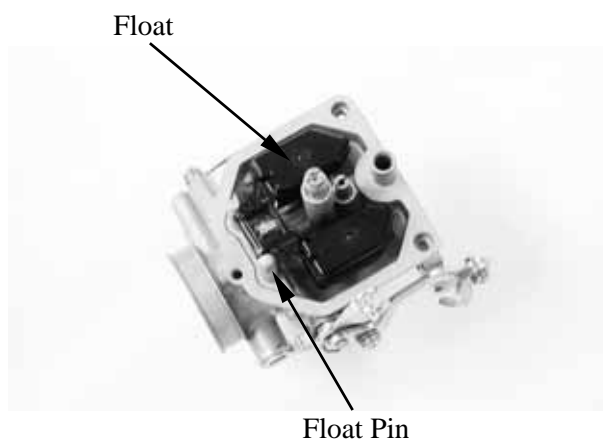

FLOAT LEVEL INSPECTION

Turn the carburetor upside down so that the float will go down to make the float valve contact the float valve seat.
Then slowly tilt the carburetor and measure the float level with the float level gauge while the float pin just contacts with float valve.

When adjusting, carefully bend the float pin.
Check the float for proper operation and then install the float chamber.

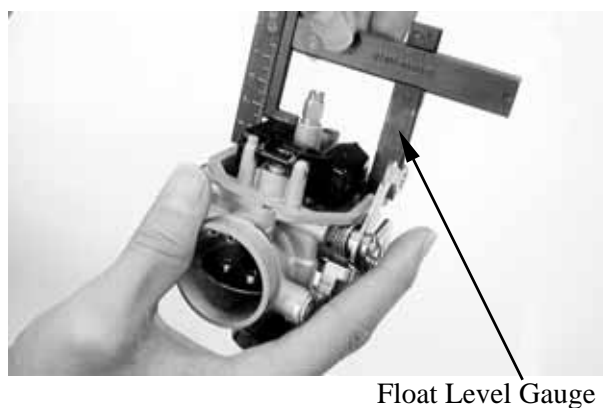

Float Level: 14.8 mm (0.592 in)

5. FUEL SYSTEM

CARBURETOR INSTALLATION

Install the carburetor onto the intake manifold and tighten the two lock nuts.

Torque: 1 kgf-m (10 N-m, 7.2 lbf-ft)

Install the air cleaner connecting tube and tighten the band screw.

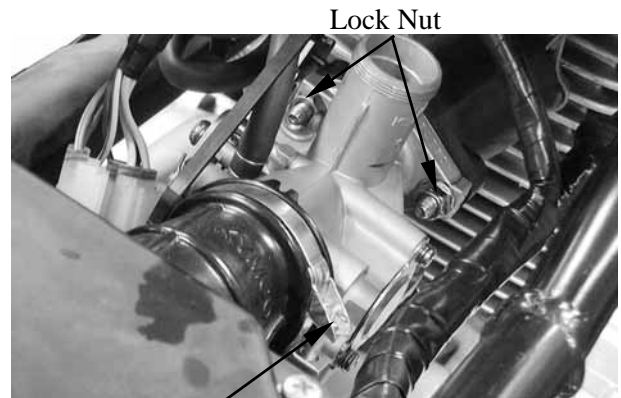

Band Screw

Lock Nut

THROTTLE VALVE ASSEMBLY

Install the jet needle into the throttle valve and secure with the needle retainer.

Jet Needle Notch: 4th Notch
(Counted from top to bottom)

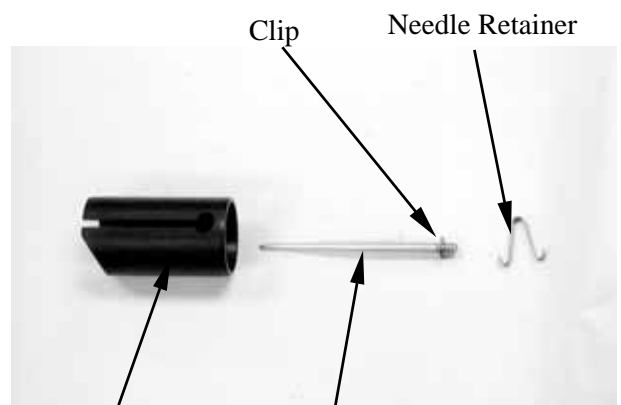

Throttle Valve

Jet Needle

Clip

Needle Retainer

Assemble the rubber cover, carburetor cap and throttle valve spring. Connect the throttle cable to the throttle valve.

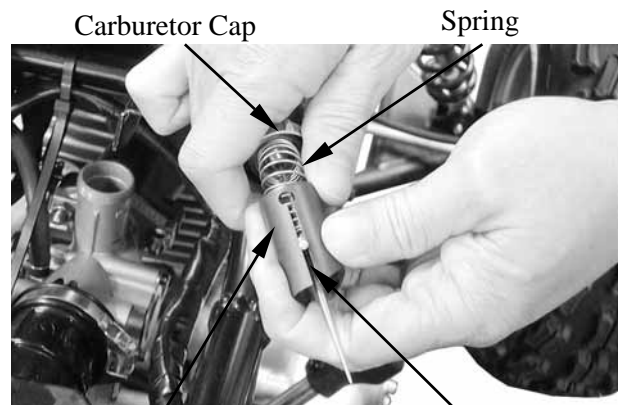

Carburetor Cap

Spring

Throttle Valve

Notch

Install the throttle valve into the carburetor body.

* Align the groove in the throttle valve with the throttle stop screw on the carburetor body.

Connect the accelerating pump cable. Fully open the throttle and adjust the accelerating pump cable to align the punch mark on the accelerating pump arm with the punch mark on the set plate.

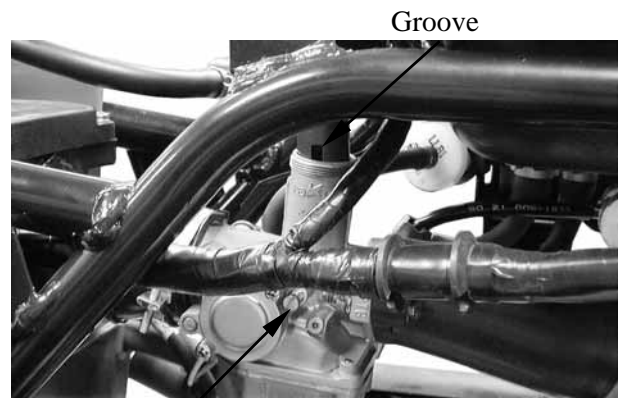

Groove

Throttle Stop Screw

5. FUEL SYSTEM

Tighten the choke cable.

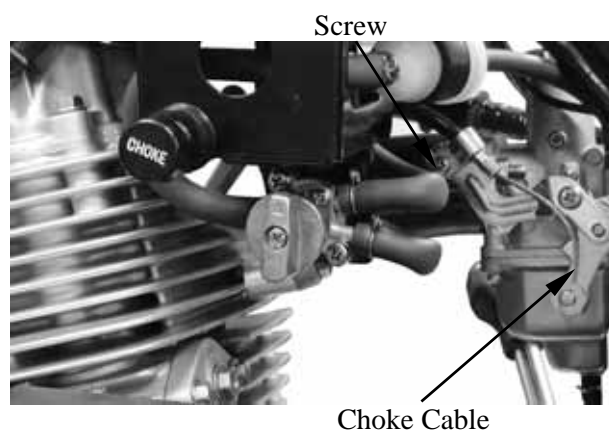

FUEL TANK

FUEL TANK REMOVAL

Warning

- Keep sparks and flames away from the work area.
- Wipe off any spilled gasoline.

Remove the seat.
Remove the center cover.
Remove the right and left front fender.

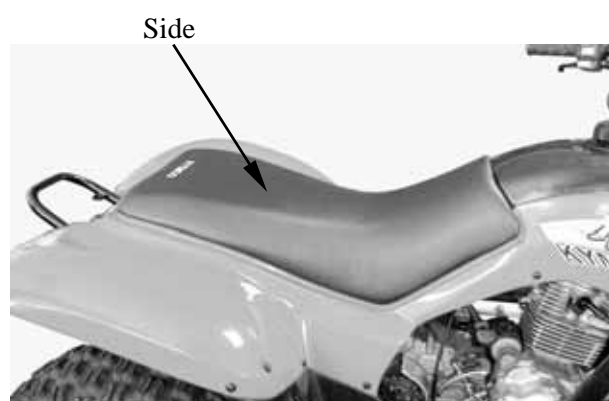

Switch the fuel valve "OFF".
Disconnect the fuel tube and remove two bolts on the end of the fuel tank.
Remove the fuel tank.

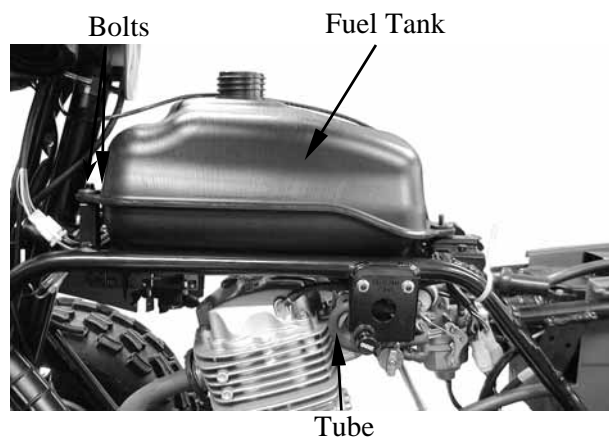

FUEL VALVE REMOVAL

Remove the fuel valve and fuel cup.

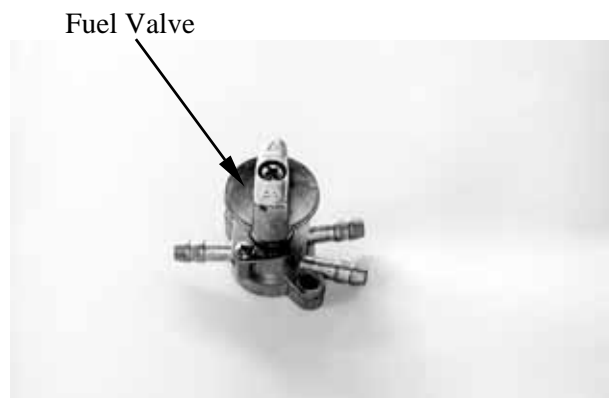

5. FUEL SYSTEM

Remove the screw on the fuel valve control switch.
Remove the two screws on the fuel valve body.

INSPECTION

Inspect the fuel valve strainer for dirt and clog. Clean if necessary.

Replace the O-rings with new ones if they are damaged or deteriorated.

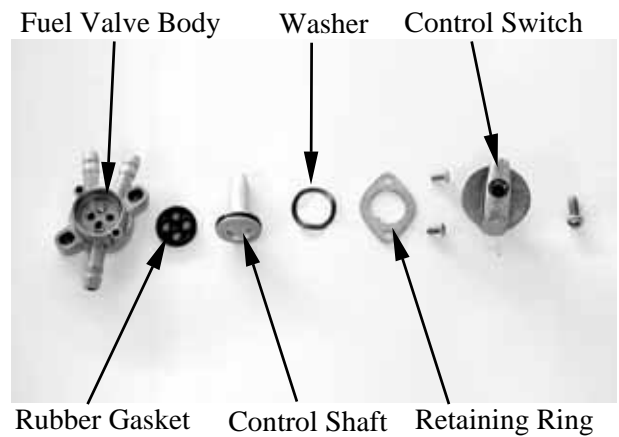

AIR CLEANER

REMOVAL

Remove the seat.
Remove the four screws on the air cleaner case cover and the cover.
Remove the air cleaner screen and element.

Refer to chapter 3 to clean air filter element.

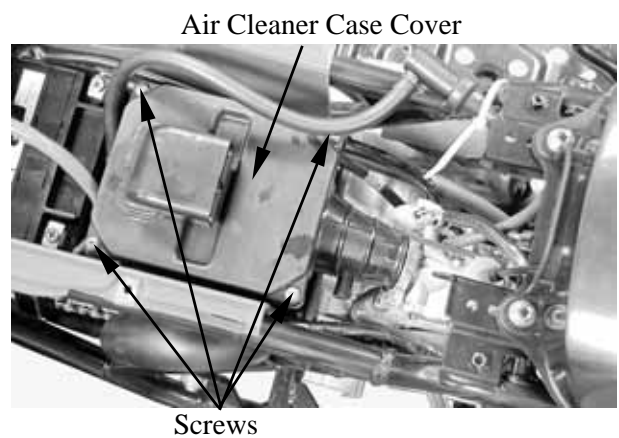

6. ENGINE REMOVAL/INSTALLATION

ENGINE REMOVAL/INSTALLATION



SERVICE INFORMATION-----	6- 1
ENGINE REMOVAL -----	6- 2
ENGINE INSTALLATION -----	6- 5

6. ENGINE REMOVAL/INSTALLATION

SERVICE INFORMATION

GENERAL INSTRUCTIONS

- A floor jack or other adjustable support is required to support and maneuver the engine. Be careful not to damage the machine body, cables and wires during engine removal.
- Use shop towels to protect the motorcycle body during engine removal.
- Parts requiring engine removal for servicing:
 - Crankcase
 - Crankshaft

6. ENGINE REMOVAL/INSTALLATION

ENGINE REMOVAL

Drain engine oil and transmission oil (refer to chapter 3).
 Remove seat, front cover, center cover, front fender, rear fender and exhaust muffler (refer to chapter 2).
 Remove the carburetor (refer to chapter 5).
 Disconnect the battery negative cable.
 Remove the frame body cover.
 Disconnect the engine negative cable.
 Disconnect the A.C.G. wire connector and neutral lamp switch.

Disconnect the starter motor cable from the starter relay.

Disconnect the crankcase breather hose from the cylinder head cover.
 Disconnect the transmission case breather hose from the transmission case.

Loosen the drive belt air cleaner connecting tube band screw and remove the connecting tube.

A.C.G. Wire Connector

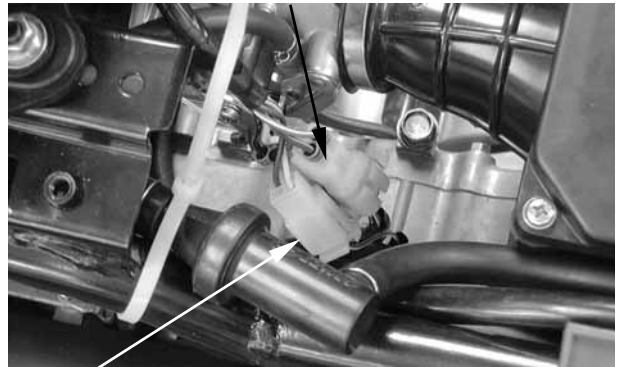

Neutral Lamp Switch

Starter Relay

Starter Motor Cable

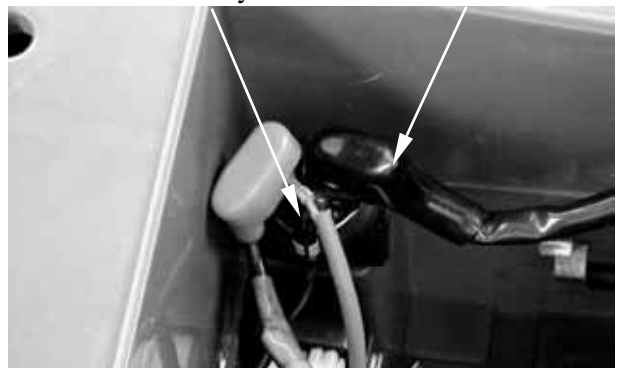

Crankcase Breather hose



Transmission Case Breather hose

Connecting Tube



Screw

6. ENGINE REMOVAL/INSTALLATION

Disconnect the spark plug high-tension wire.
Remove the spark plug cap and disconnect the ignition coil wire from the set plate.



Ignition Coil Wire

Remove the rear drive chain gear on the bolts.
Remove the drive chain gear.

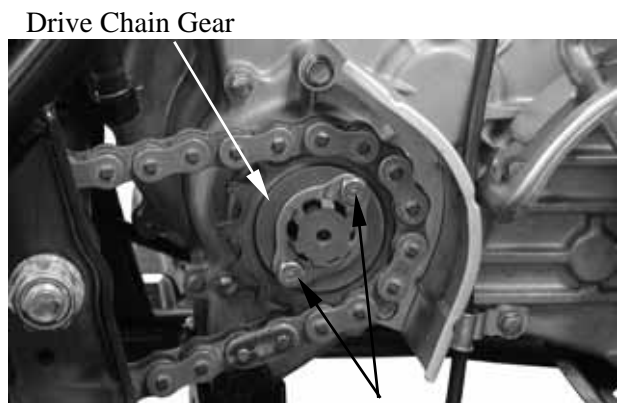

Drive Chain Gear

Bolts

Remove the pair control solenoid valve from the frame.



Pair Control Solenoid Valve

6. ENGINE REMOVAL/INSTALLATION

MXU 150 only:

Remove the nuts from the drive select lever holder.

Remove the bolt/nut from the drive select arm.

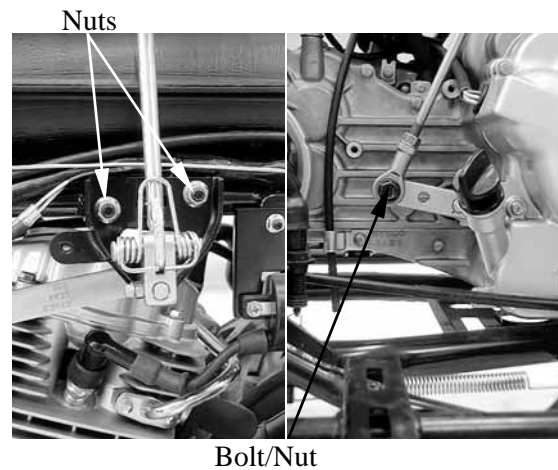

Remove the two rear engine bracket bolts/nuts.

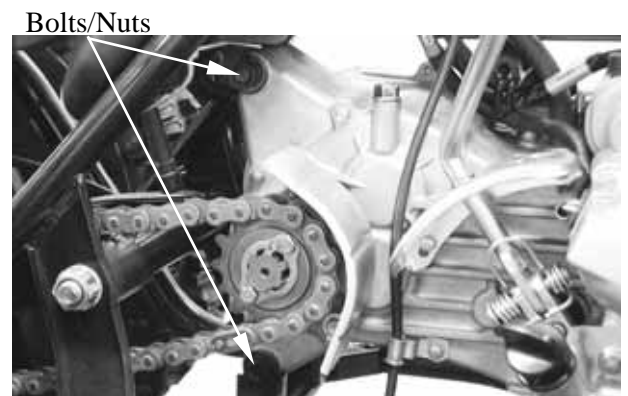

Remove the front engine bracket bolt/nut.

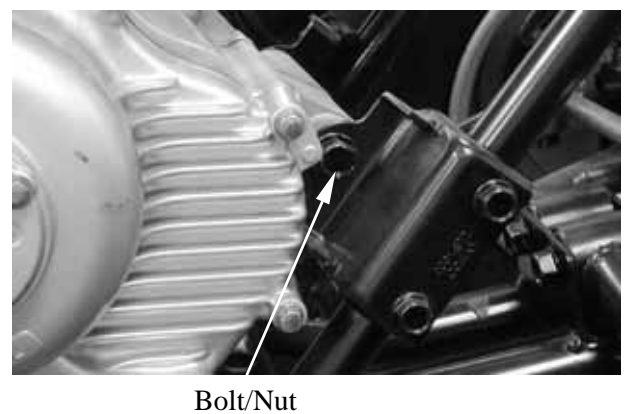

6. ENGINE REMOVAL/INSTALLATION

Engine Bracket

ENGINE HANGER BRACKET REMOVE

Remove the two bolts on the left/right engine bracket.

Remove the left/right engine bracket.

Remove the engine.

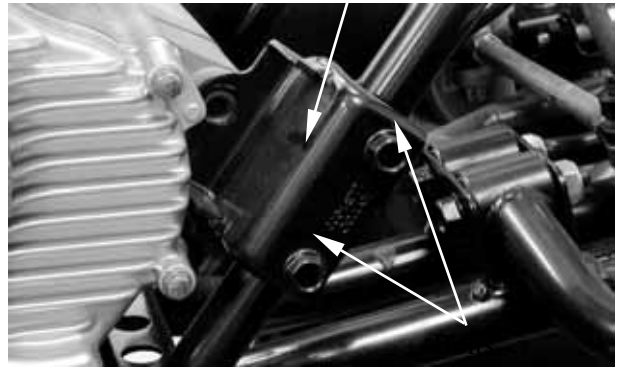

ENGINE INSTALLATION

Install the engine and tighten the engine mounting bolts/nuts.

Torque: 4 kgf-m (40 N-m, 29 lbf-ft)

Install the removed parts in the reverse order of removal.

* Route the wires and hose properly.



7. CYLINDER HEAD/VALVES

CYLINDER HEAD/VALVES

SERVICE INFORMATION-----	7- 2
TROUBLESHOOTING-----	7- 3
CAMSHAFT REMOVAL-----	7- 4
CYLINDER HEAD REMOVAL-----	7- 7
CYLINDER HEAD DISASSEMBLY-----	7- 8
CYLINDER HEAD ASSEMBLY-----	7-10
CYLINDER HEAD INSTALLATION-----	7-10
CAMSHAFT INSTALLATION-----	7-11

7. CYLINDER HEAD/VALVES

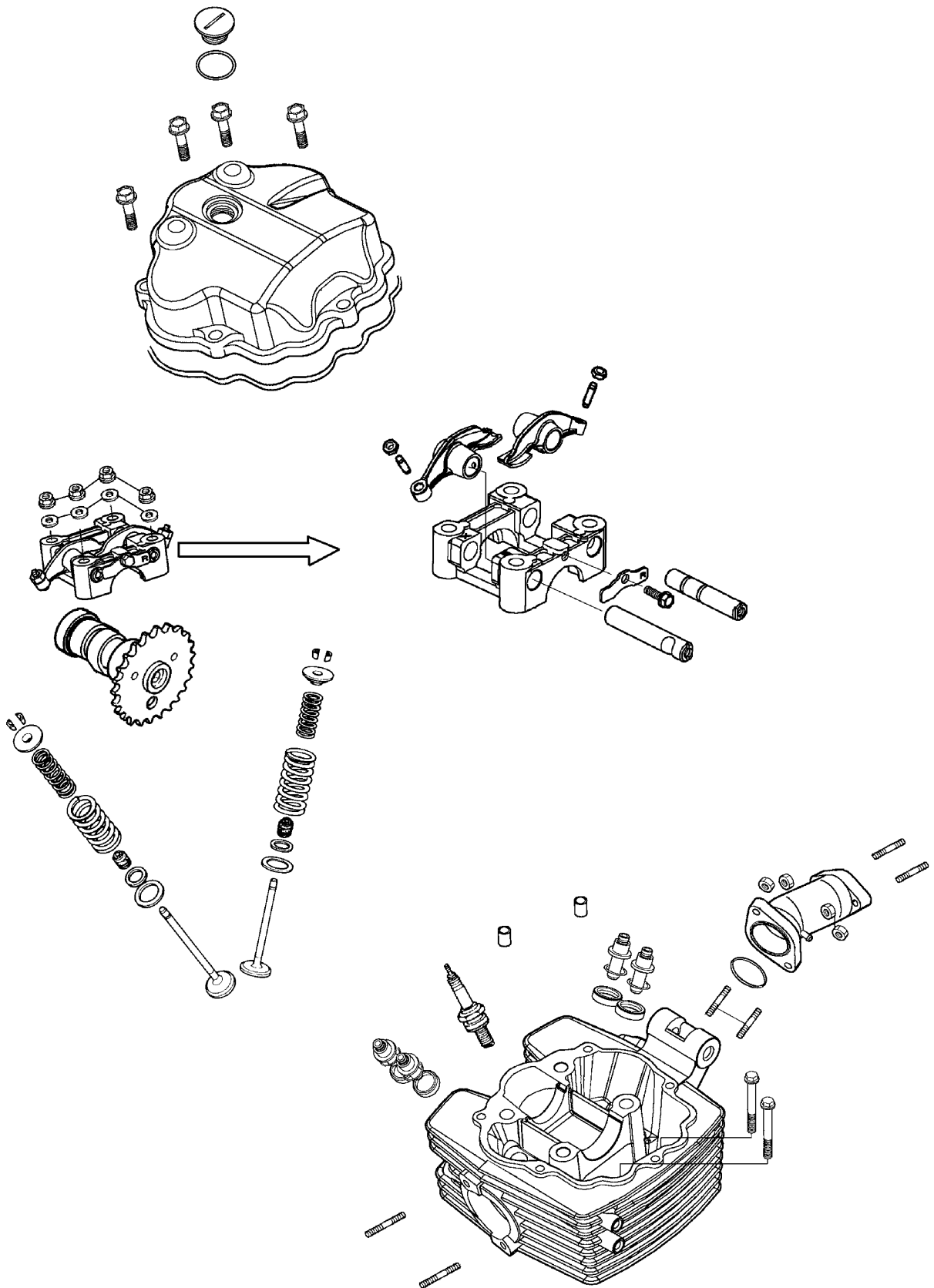

7. CYLINDER HEAD/VALVES

SERVICE INFORMATION

GENERAL INSTRUCTIONS

- The cylinder head can be serviced with the engine installed in the frame.
- When assembling, apply molybdenum disulfide grease or engine oil to the valve guide movable parts, valve arm and camshaft sliding surfaces for initial lubrication.
- The camshaft is lubricated by engine oil through the cylinder head engine oil passages. Clean and unclog the oil passages before assembling the cylinder head.
- After disassembly, clean the removed parts and dry them with compressed air before inspection.
- After removal, mark and arrange the removed parts in order. When assembling, install them in the reverse order of removal.

SPECIFICATIONS

mm (in)

Item		Standard	Service Limit
Valve clearance (cold)	IN	0.06 (0.0024)	—
	EX	0.06 (0.0024)	—
Cylinder head compression pressure		1600 kPa (16 kg/cm ² , 227.2 psi)	
Cylinder head warpage		—	0.05 (0.002)
Camshaft cam height	IN	31.8 (1.272)	31.4 (1.256)
	EX	31.53 (1.2612)	31.13 (1.2452)
Valve rocker arm to shaft clearance		0.09~0.034 (0.0036~0.00136)	0.1 (0.004)
Valve stem-to-guide clearance	IN	0.01~0.037 (0.0004~0.00148)	0.06 (0.0024)
	EX	0.025~0.052 (0.001~0.00208)	0.08 (0.0032)
Valve spring free length	IN	39.4 (1.576)	38.2 (1.528)
	EX	45.5 (1.82)	44.3 (1.772)
Valve spring compressed force	IN	7.7~8.9 kg(at 33.7 mm)	—
	EX	19.5~22.5 kg(at 38.4 mm)	—
Valve spring tilt	IN	1.7 (0.068)	—
	EX	1.95 (0.078)	—

7. CYLINDER HEAD/VALVES

TORQUE VALUES

Cylinder head nut	2 kgf-m (20 N-m, 14 lbf-ft)	Apply engine oil to threads
Valve clearance adjusting nut	0.9 kgf-m (9 N-m, 6.5 lbf-ft)	Apply engine oil to threads
Stud bolt	0.9 kgf-m (9 N-m, 6.5 lbf-ft)	

SPECIAL TOOLS

Valve spring compressor	E040
Tappet adjuster	E012

TROUBLESHOOTING

- The poor cylinder head operation can be diagnosed by a compression test or by tracing engine top-end noises.

Poor performance at idle speed

- Compression too low

Compression too low

- Incorrect valve clearance adjustment
- Burned or bent valves
- Incorrect valve timing
- Broken valve spring
- Poor valve and seat contact
- Leaking cylinder head gasket
- Warped or cracked cylinder head
- Poorly installed spark plug

Compression too high

- Excessive carbon build-up in combustion chamber

White smoke from exhaust muffler

- Worn valve stem or valve guide
- Damaged valve stem seal

Abnormal noise

- Incorrect valve clearance adjustment
- Sticking valve or broken valve spring
- Damaged or worn camshaft
- Worn cam chain guide
- Worn camshaft and rocker arm

7. CYLINDER HEAD/VALVES

CAMSHAFT REMOVAL

Remove seat, front cover, center cover.
Front fender, fuel tank and exhaust pipe.

Remove the four cylinder head cover bolts
to remove the cylinder head cover.

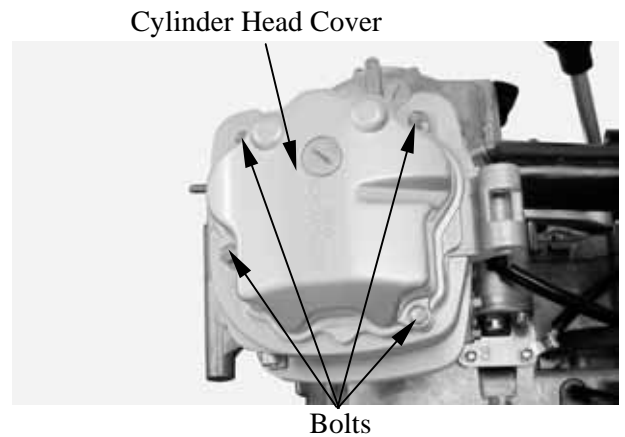

Remove the cam chain tensioner cap bolt
and the O-ring.



Turn the cam chain tensioner screw
clockwise to tighten it.

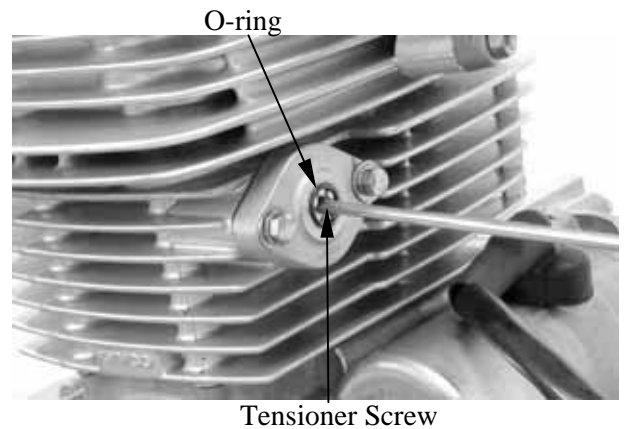

Turn the flywheel counterclockwise so that
the "T" mark on the flywheel aligns with
the index mark on the crankcase to bring the
round hole on the camshaft gear facing up
to the top dead center on the compression
stroke.

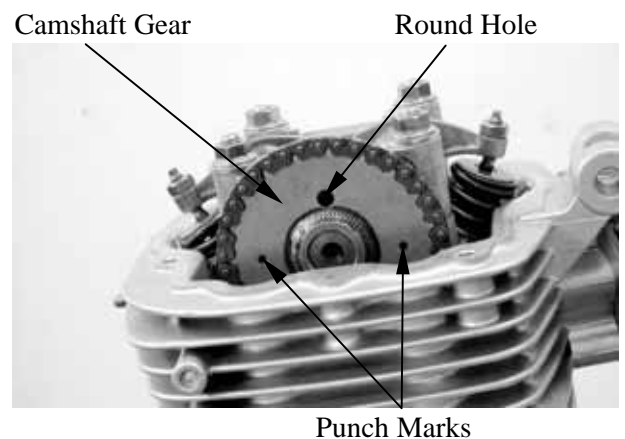

7. CYLINDER HEAD/VALVES

Remove the four cylinder head nuts and washers.

* Diagonally loosen the cylinder head nuts in 2 or 3 times.

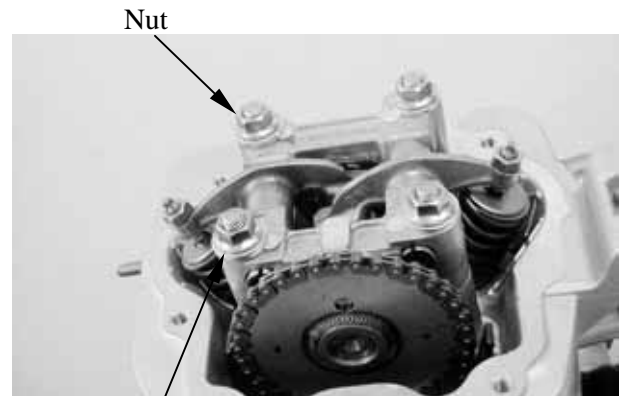

Remove the camshaft holder and dowel pins.

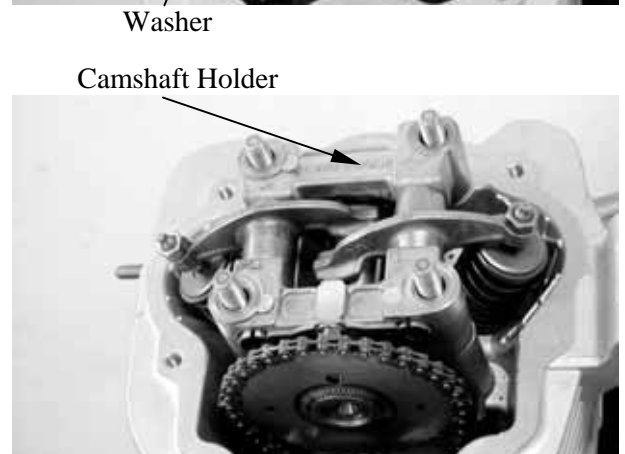

Remove the camshaft gear from the cam chain and remove the camshaft.

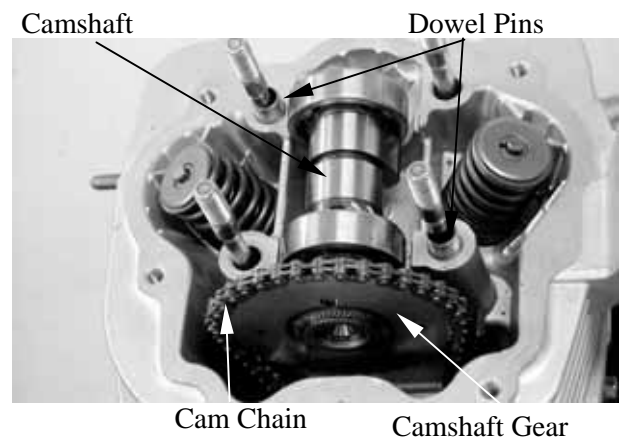

CAMSHAFT INSPECTION

Check each cam lobe for wear or damage.
Measure the cam lobe height.

Service Limits:

IN : 31.4 mm (1.256 in)

EX: 31.13 mm (1.2452 in)



7. CYLINDER HEAD/VALVES

Check each camshaft bearing for play or damage. Replace the camshaft assembly with a new one if the bearings are noisy or have excessive play.

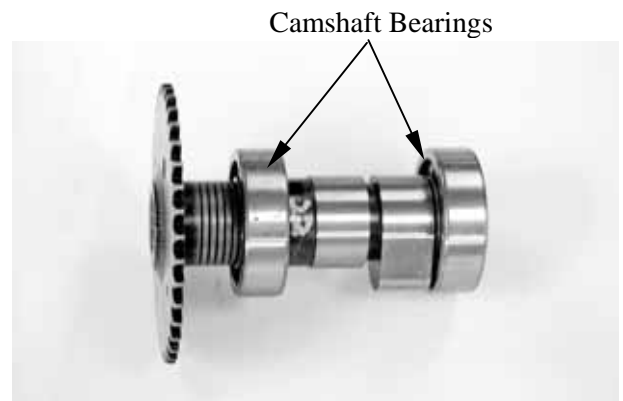

CAMSHAFT HOLDER DISASSEMBLY

Remove the bolt attaching the stop plate.
Take out the valve rocker arm shafts using a 5mm bolt.
Remove the valve rocker arms.

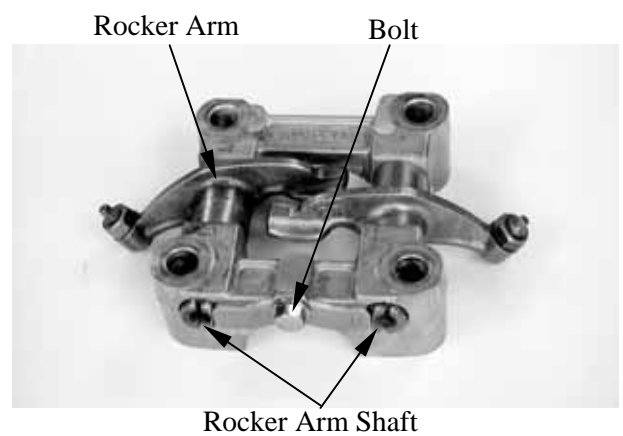

CAMSHAFT HOLDER INSPECTION

Inspect the camshaft holder, valve rocker arms and rocker arm shafts for wear or damage.

* If the valve rocker arm contact surface is worn, check each cam lobe for wear or damage.

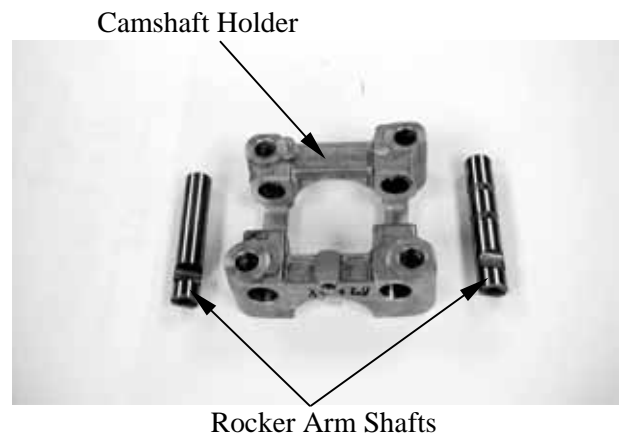

Measure the I.D. of each valve rocker arm.
Measure each rocker arm shaft O.D.
Measure arm to shaft clearance.
Replace as a set if out of specification.
Service limits: 0.1 mm (0.004 in)



7. CYLINDER HEAD/VALVES

CYLINDER HEAD REMOVE

Remove the camshaft.
Remove the carburetor.
Remove the exhaust muffler.
Remove the carburetor intake manifold.

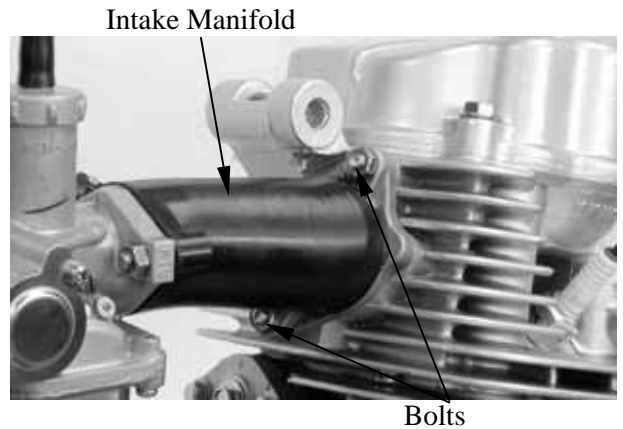

Remove the two cylinder head bolts.
Remove the cylinder head.

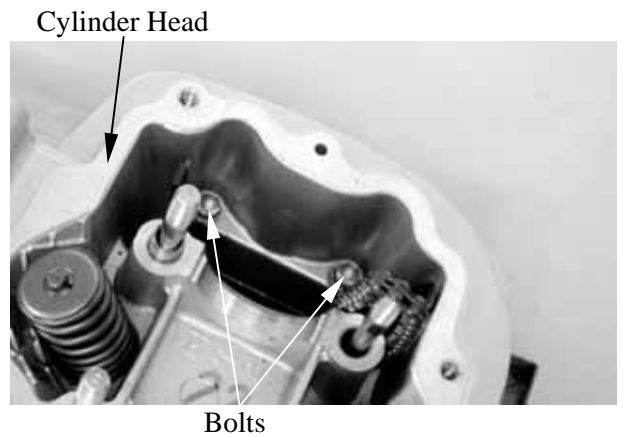

Remove the dowel pins and cylinder head gasket.
Remove the cam chain guide.

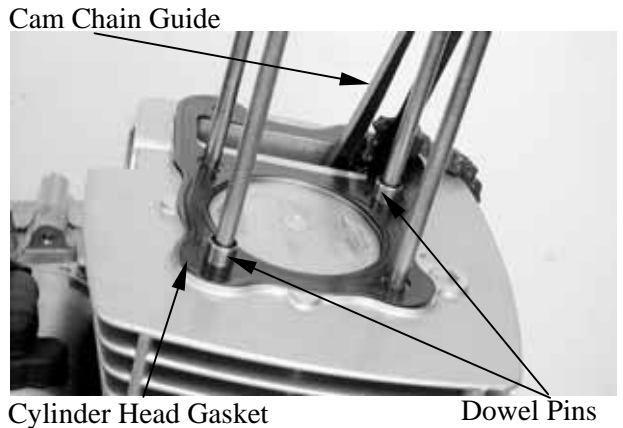

Remove all gasket material from the cylinder mating surface.

- * Avoid damaging the cylinder mating surface.
- * Be careful not to drop any gasket material into the engine.

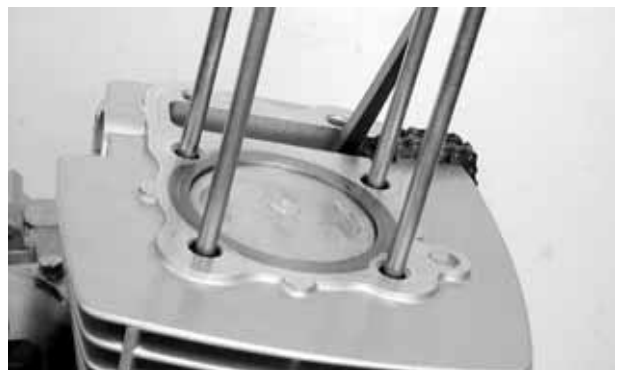

7. CYLINDER HEAD/VALVES

CYLINDER HEAD DISASSEMBLY

Remove the valve spring cotters, retainers, springs, spring seats and valve stem seals using a valve spring compressor.

- * Be sure to compress the valve springs with a valve spring compressor.
- * Mark all disassembled parts to ensure correct reassembly.

Special tool:

Valve Spring Compressor E040

Remove carbon deposits from the combustion chamber.
Clean off any gasket material from the cylinder head mating surface.

- * Be careful not to damage the cylinder head mating surface.

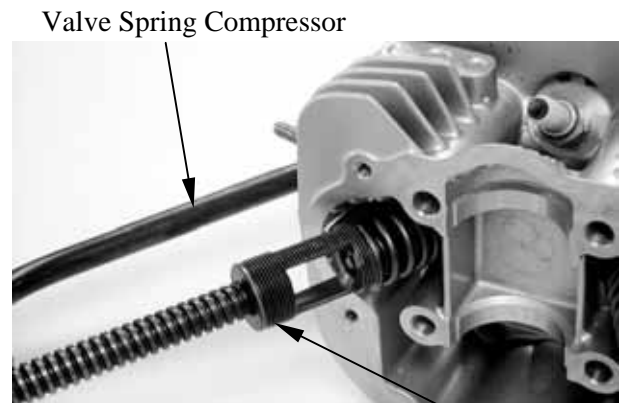

INSPECTION CYLINDER HEAD

Check the spark plug hole and valve areas for cracks.
Check the cylinder head for warpage with a straight edge and feeler gauge.

Service Limit: 0.05 mm (0.002 in)



VALVE /VALVE GUIDE

Inspect each valve for bending, burning, scratches or abnormal stem wear.
Check valve movement in the guide.
Measure each valve stem O.D.

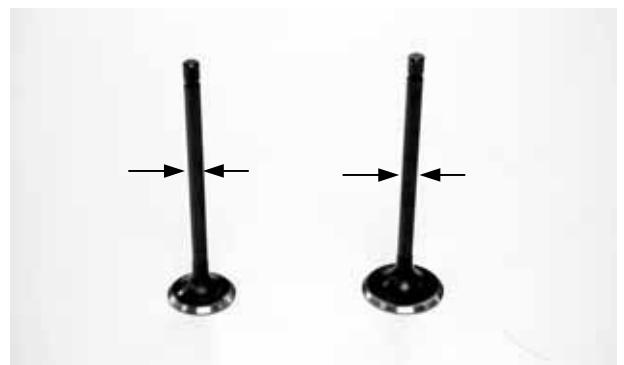

7. CYLINDER HEAD/VALVES

Measure each valve guide I.D.

Subtract each valve stem O.D. from the corresponding guide I.D. to obtain the stem-to-guide clearance.

Service limits: IN : 0.06 mm (0.0024 in)
 EX: 0.08 mm (0.0032 in)

* If the stem-to-guide clearance exceeds the service limits, replace the cylinder head as necessary.



VALVE SPRING FREE LENGTH

Measure the free length of the inner and outer valve springs.

Inner : 38.2 mm (1.528 in)

Outer: 44.3 mm (1.772 in)

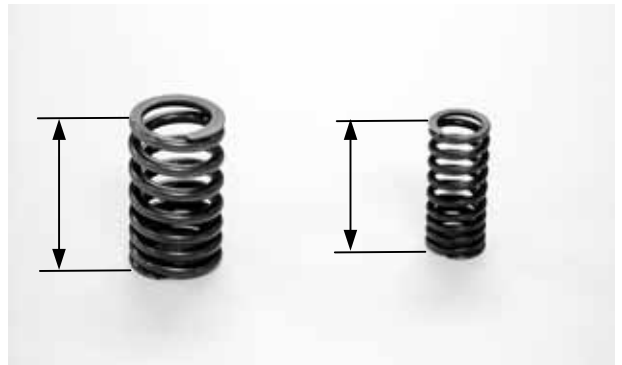

Measure compressed force (valve spring) and installed length.

Replace if out of specification.

Service limits:

IN : 7.7~8.9 kg (at 33.7mm)

EX : 19.5~22.5 kg (at 38.4mm)

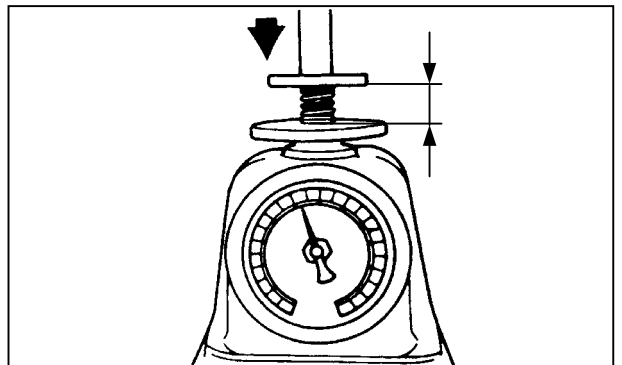

Measure the spring tilt.

Replace if out of specification.

Service limits: IN : 1.7 mm (0.068 IN)

EX : 1.95 mm (0.078)

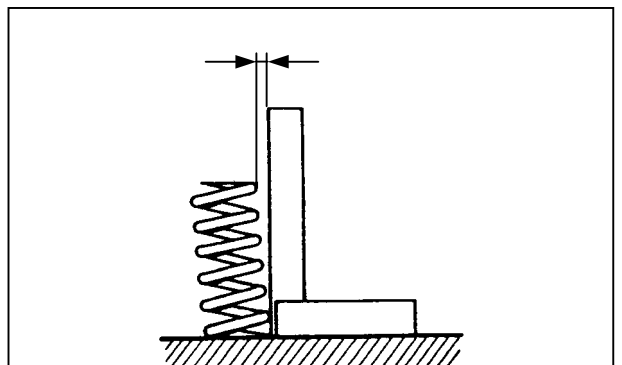

7. CYLINDER HEAD/VALVES

CYLINDER HEAD ASSEMBLY

Install the valve spring seats and valve stem seals.

- * Be sure to install new valve stem seals.

Lubricate each valve stem with engine oil and insert the valves into the valve guides. Install the valve springs and retainers.



Compress the valve springs using the valve spring compressor, then install the valve cotters.

- * When assembling, a valve spring compressor must be used.
- * Install the cotters with the pointed ends facing down from the upper side of the cylinder head.

Valve Spring Compressor

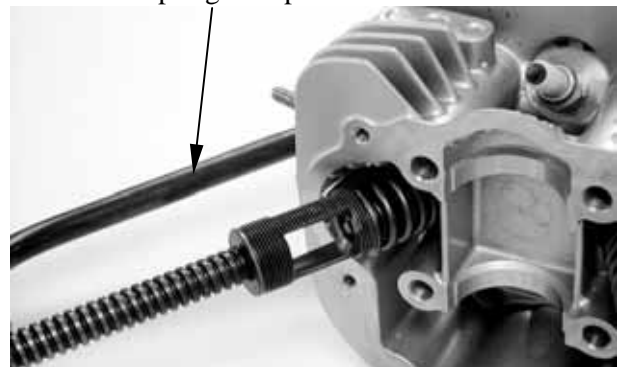

Special tool:

Valve Spring Compressor E040

Tap the valve stems gently with a plastic hammer for 2~3 times to firmly seat the cotters.

- * Be careful not to damage the valves.



CYLINDER HEAD INSTALLATION

Install the dowel pins and a new cylinder head gasket. Install the cam chain guide.

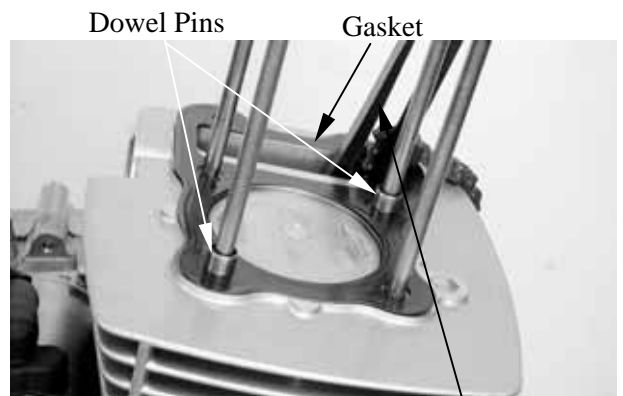

Cam Chain Guide

7. CYLINDER HEAD/VALVES

Install the cylinder head.

Install two cylinder head bolts do not tighten completely.

- * Tighten the two cylinder head bolts after the camshaft holder nuts have tightened (see page 7-12).

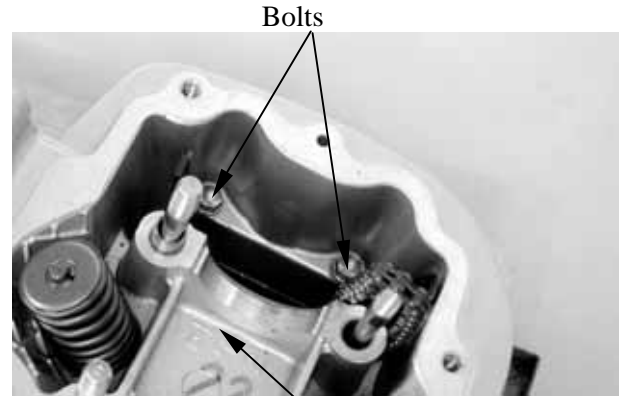

Boles
Cylinder Head

CAMSHAFT HOLDER ASSEMBLY

Install the exhaust valve rocker arm to the "EX" mark side of the camshaft holder.

Install the intake valve rocker arm and the rocker arm shafts.

Tighten the bolt attaching stop plate.

- *
 - Align the cutout on the front end of the intake valve rocker arm shaft with the bolt of the camshaft holder.
 - Align the cross cutout on the exhaust valve rocker arm shaft with the bolt of the camshaft holder.

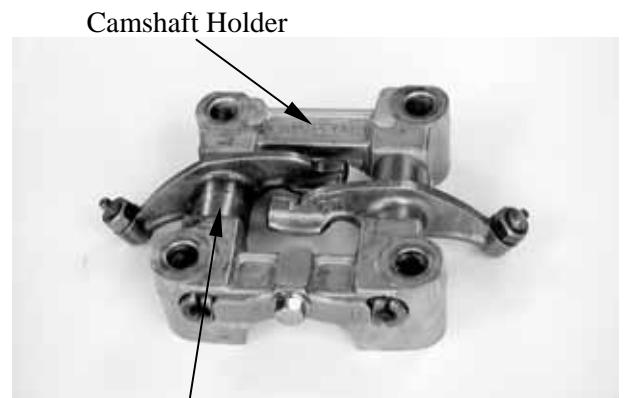

Camshaft Holder

Valve Rocker Arm

CAMSHAFT INSTALLATION

Turn the flywheel so that the "T" mark on the flywheel aligns with the index mark on the crankcase.

Keep the round hole on the camshaft gear facing up and align the punch marks on the camshaft gear with the cylinder head surface (Position the intake and exhaust cam lobes down.) and install the camshaft onto the cylinder head.

Install the cam chain over the camshaft gear.

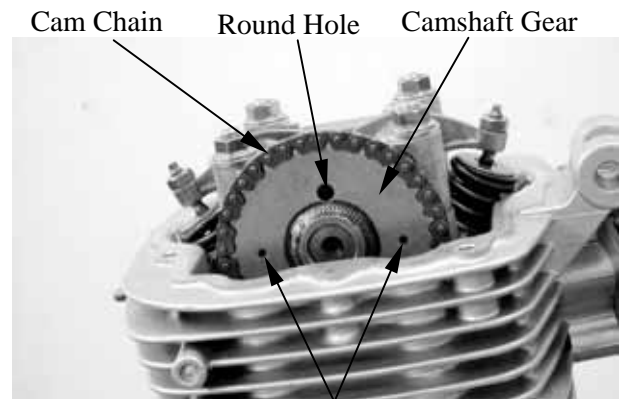

Cam Chain Round Hole Camshaft Gear

Punch Marks

Install the dowel pins.

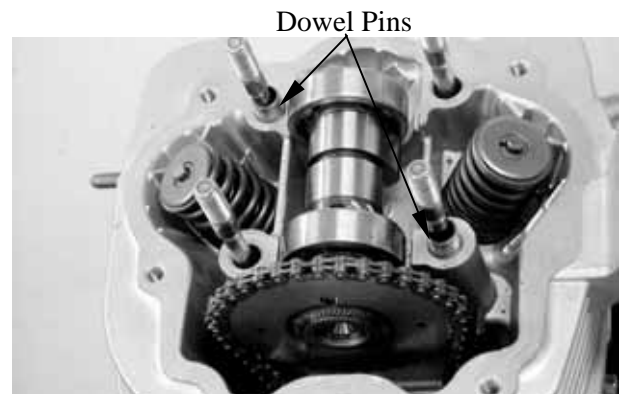

Dowel Pins

7. CYLINDER HEAD/VALVES

Install the camshaft holder, washers and nuts on the cylinder head.
Tighten the four cylinder head nuts, then tighten two cylinder head bolts completely.

Torque:

Cylinder head nut:
2 kgf-m (20 N-m, 14 lbf-ft)
Cylinder head bolt (see page 7-11):
1 kgf-m (10 N-m, 7.2 lbf-ft)

- * Apply engine oil to the threads of the cylinder head nuts.
- * Diagonally tighten the cylinder head nuts in 2~3 times.

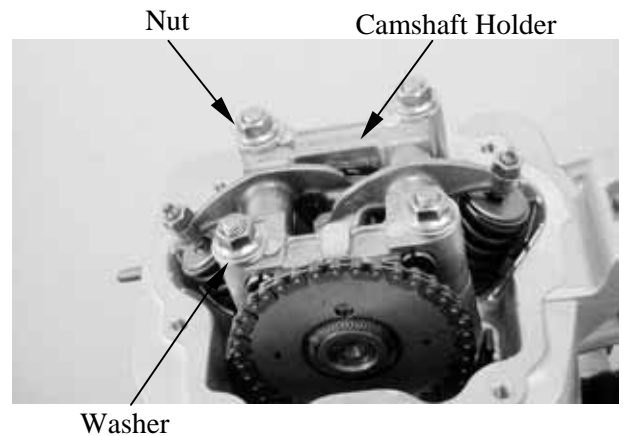

Adjust the valve clearance.
Turn the cam chain tensioner screw counter-clockwise to release it.

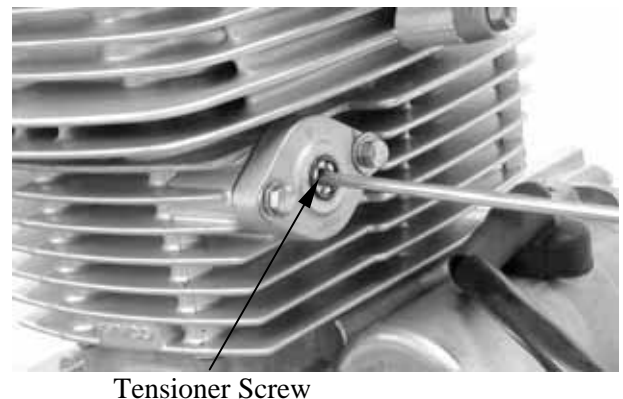

Apply engine oil to a new O-ring and install it.
Tighten the cam chain tensioner cap bolt.

- * Be sure to install the O-ring into the groove properly.

Refer to the chapter 3 to perform valve clearance adjustment.

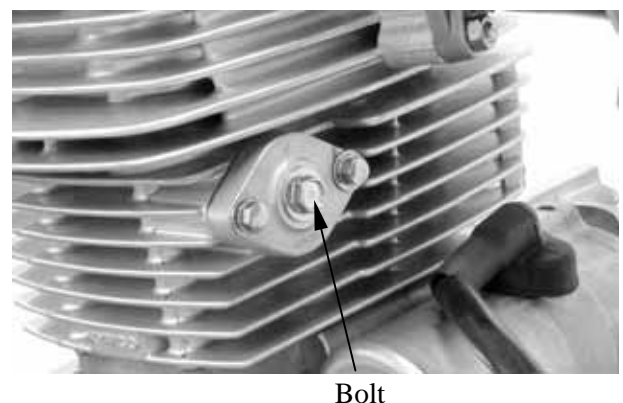

7. CYLINDER HEAD/VALVES

Install a new cylinder head cover O-ring and install the cylinder head cover. Install and tighten the cylinder head cover bolts.

* Be sure to install the O-ring into the groove properly.

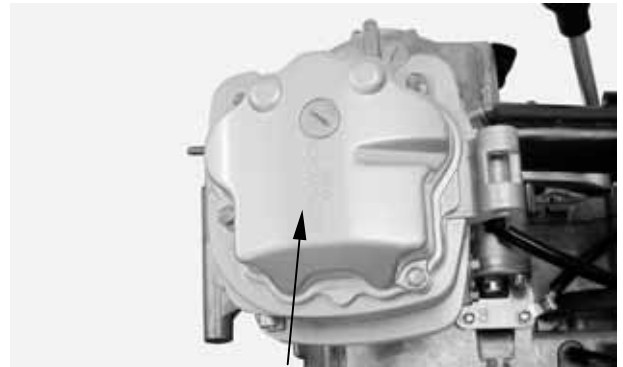

Cylinder Head Cover

8. CYLINDER/PISTON

CYLINDER /PISTON

SERVICE INFORMATION-----	8- 2
TROUBLESHOOTING-----	8- 2
CYLINDER REMOVAL -----	8- 5
PISTON REMOVAL-----	8- 5
PISTON INSTALLATION-----	8- 9
CYLINDER INSTALLATION -----	8- 9



8. CYLINDER/PISTON

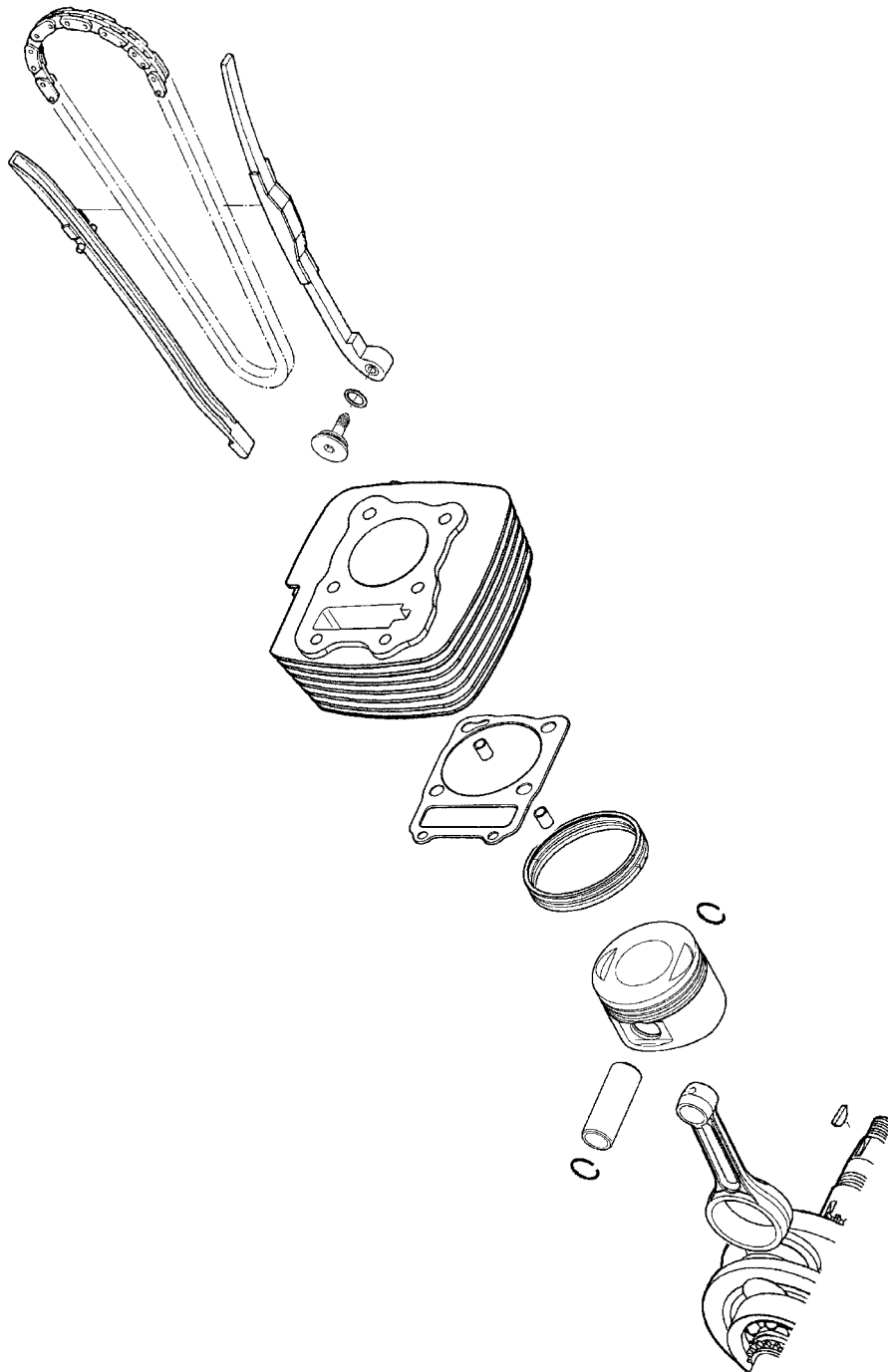

8. CYLINDER/PISTON

SERVICE INFORMATION

GENERAL INSTRUCTIONS

- The cylinder and piston can be serviced with the engine installed in the frame.
- After disassembly, clean the removed parts and dry them with compressed air before inspection.

TROUBLESHOOTING

- When hard starting or poor performance at low speed occurs, check the crankcase breather for white smoke. If white smoke is found, it means that the piston rings are worn, stuck or broken.

Compression too low or uneven compression

- Worn, stuck or broken piston rings
- Worn or damaged cylinder and piston

Compression too high

- Excessive carbon build-up in combustion chamber or on piston head

Excessive smoke from exhaust muffler

- Worn or damaged piston rings
- Worn or damaged cylinder and piston

Abnormal noisy piston

- Worn cylinder, piston and piston rings
- Worn piston pin hole and piston pin

8. CYLINDER/PISTON

SPECIFICATIONS

mm (in)

ATV 150		Standard	Service Limit	
Cylinder	I.D.	62.03 ~ 62.045 (2.4812 ~ 2.4818)	62.1 (2.484)	
	Warpage	—	0.05 (0.002)	
	Cylindricity	—	0.05 (0.002)	
	True roundness	—	0.05 (0.002)	
Piston, piston ring	Ring-to-groove clearance	Top	0.015 ~ 0.055 (0.006 ~ 0.0022)	0.09 (0.0036)
		Second	0.015 ~ 0.055 (0.006 ~ 0.0022)	0.09 (0.0036)
	Ring end gap	Top	0.1 ~ 0.25 (0.004 ~ 0.01)	0.5 (0.02)
		Second	0.1 ~ 0.25 (0.004 ~ 0.01)	0.5 (0.02)
		Oil side rail	0.2 ~ 0.7 (0.008 ~ 0.028)	—
	Piston O.D.	61.96 ~ 62 (2.4784 ~ 2.48)	61.9 (2.476)	
	Piston O.D. measuring position	5 (0.2) from bottom of skirt	—	
	Piston-to-cylinder clearance	0.01 ~ 0.04 (0.0004 ~ 0.0016)	0.1 (0.004)	
Piston pin hole I.D.	15.002 ~ 15.008 (0.60008 ~ 0.60016)	15.04 (0.6016)		
Piston pin O.D.		14.994 ~ 15 (0.59976 ~ 0.6)	14.96 (0.5984)	
Piston-to-piston pin clearance		0.002 ~ 0.014 (0.00008 ~ 0.00056)	0.02 (0.008)	
Connecting rod small end I.D. bore		15.016 ~ 15.034 (0.60064 ~ 0.60136)	15.06 (0.6024)	

8. CYLINDER/PISTON

SPECIFICATIONS

mm (in)

ATV 125		Standard	Service Limit	
Cylinder	I.D.	56.53 ~ 56.545 (2.2612 ~ 2.2618)	56.6 (2.264)	
	Warpage	—	0.05 (0.002)	
	Cylindricity	—	0.05 (0.002)	
	True roundness	—	0.05 (0.002)	
Piston, piston ring	Ring-to-groove clearance	Top	0.015 ~ 0.055 (0.006 ~ 0.0022)	0.09 (0.0036)
		Second	0.015 ~ 0.055 (0.006 ~ 0.0022)	0.09 (0.0036)
	Ring end gap	Top	0.1 ~ 0.25 (0.004 ~ 0.01)	0.5 (0.02)
		Second	0.1 ~ 0.25 (0.004 ~ 0.01)	0.5 (0.02)
		Oil side rail	0.2 ~ 0.7 (0.008 ~ 0.028)	—
	Piston O.D.	56.46 ~ 56.5 (2.2584 ~ 2.26)	56.4 (2.256)	
	Piston O.D. measuring position	5 (0.2) from bottom of skirt	—	
	Piston-to-cylinder clearance	0.01 ~ 0.04 (0.0004 ~ 0.0016)	0.1 (0.004)	
Piston pin hole I.D.	15.002 ~ 15.008 (0.60008 ~ 0.30016)	15.04 (0.6016)		
Piston pin O.D		14.994 ~ 15 (0.59976 ~ 0.6)	14.96 (0.5984)	
Piston-to-piston pin clearance		0.002 ~ 0.014 (0.00008 ~ 0.00056)	0.02 (0.008)	
Connecting rod small end I.D. bore		15.016 ~ 15.034 (0.60064 ~ 0.60136)	15.06 (0.6024)	

8. CYLINDER/PISTON

CYLINDER REMOVAL

Turn the cam chain tension screw clockwise to tighten it.
Remove the two bolts on the cam chain tension.

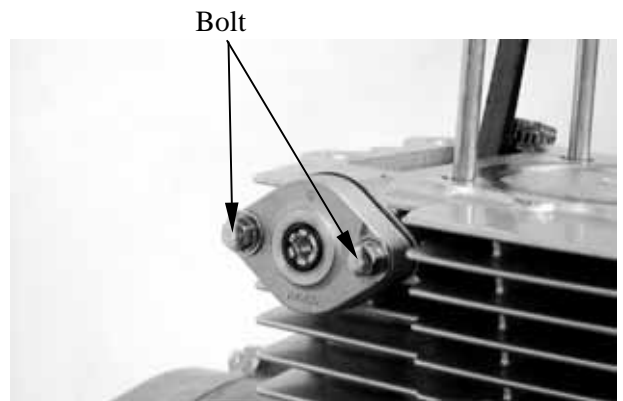

Remove the cylinder head.
Remove the cam chain guide.
Remove the cylinder base bolts.
Remove the cylinder

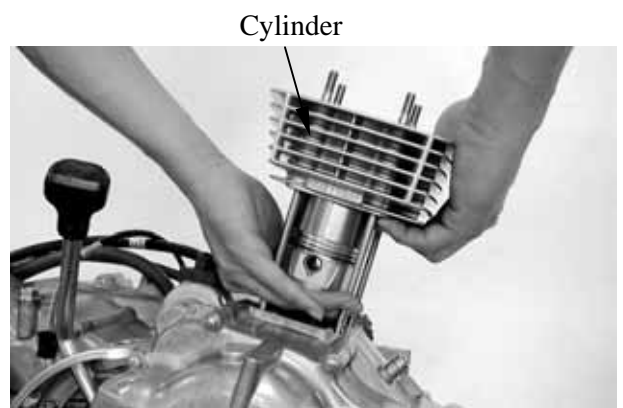

Remove the cylinder gasket and dowel pins.
Clean any gasket material from the cylinder surface.



PISTON REMOVAL

Remove the piston pin clip.

* Place a clean shop towel in the crankcase to keep the piston pin clip from falling into the crankcase.

Press the piston pin out of the piston and remove the piston.

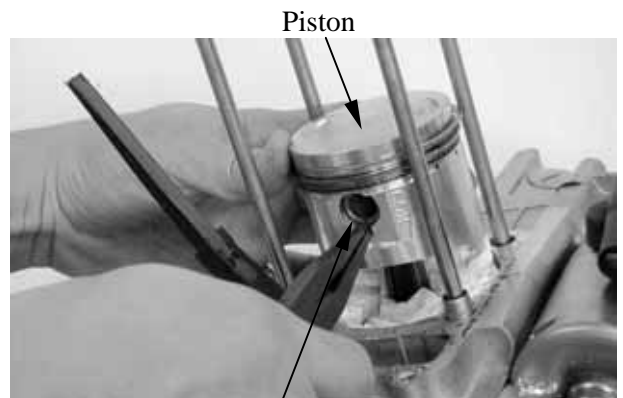

8. CYLINDER/PISTON

Inspect the piston, piston pin and piston rings.

Remove the piston rings.

* Take care not to damage or break the piston rings during removal.

Clean carbon deposits from the piston ring grooves.



Install the piston rings onto the piston and measure the piston ring-to-groove clearance.

Service Limits: Top: 0.09 mm (0.0036 in)

2nd: 0.09mm (0.0036 in)



Remove the piston rings and insert each piston ring into the cylinder bottom.

* Use the piston head to push each piston ring into the cylinder.

Measure the piston ring end gap.

Service Limit: 0.5 mm (0.02 in)

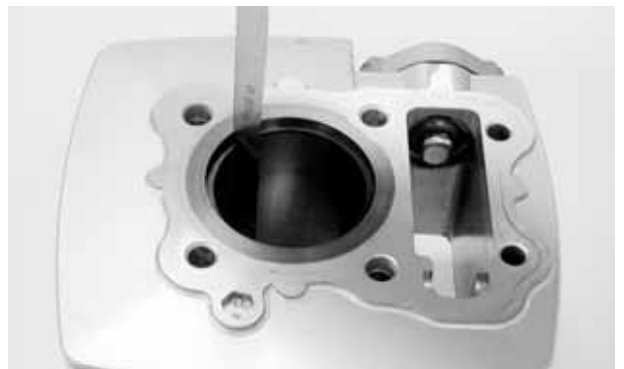

Measure the piston pin hole I.D.

Service Limit: 15.04 mm (0.6016 in)



8. CYLINDER/PISTON

Measure the piston pin O.D.

Service Limit: 14.96 mm (0.5984 in)

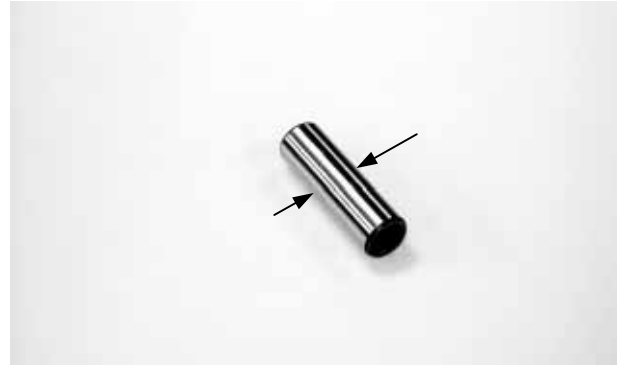

Measure the piston O.D.

* Take measurement at 5mm from the bottom and 90° to the piston pin hole.

Piston O.D. (ATV 150): 61.9 mm (2.476 in)

Piston O.D. (ATV 125): 56.4 mm (2.256 in)

Measure the piston-to-piston pin clearance.

Service Limit: 0.02 mm (0.0008 in)



CYLINDER INSPECTION

Inspect the cylinder bore for wear or damage. Measure the cylinder I.D. at three levels of top, middle and bottom at 90° to the piston pin (in both X and Y directions).

Cylinder I.D.:

(ATV 150): 62.1 mm (2.484 in)

(ATV 125): 56.6 mm (2.264 in)

Measure the cylinder-to-piston clearance.

Service Limit: 0.1mm (0.004 in)

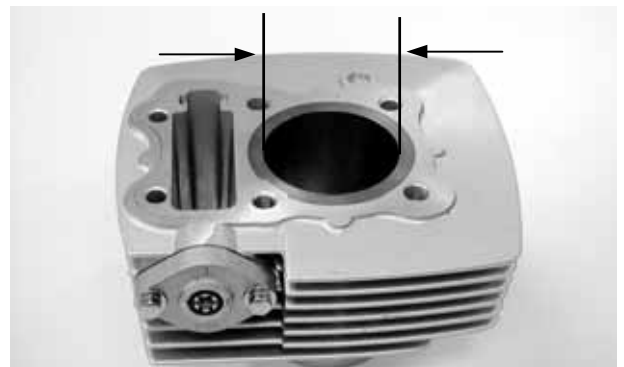

The true roundness is the difference between the values measured in X and Y directions. The cylindricity (difference between the values measured at the three levels) is subject to the maximum value calculated.

Service Limits:

True Roundness: 0.05 mm (0.002 in)

Cylindricity: 0.05 mm (0.002 in)

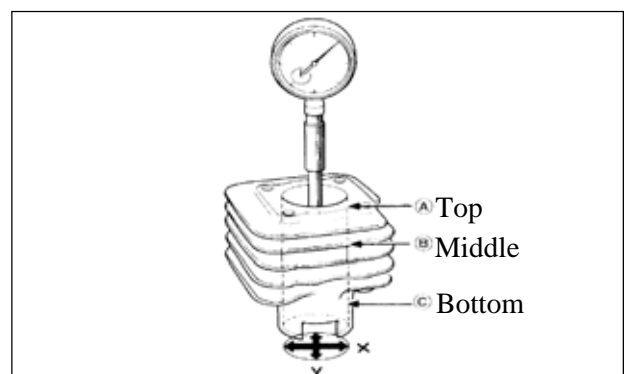

8. CYLINDER/PISTON

Inspect the top of the cylinder for warpage.

Service Limit: 0.05 mm (0.002 in)



Measure the connecting rod small end I.D.

Service Limit: 15.06 mm (0.6024 in)



PISTON RING INSTALLATION

Install the piston rings onto the piston.
Apply engine oil to each piston ring.

- *
- Be careful not to damage or break the piston and piston rings.
 - All rings should be installed with the markings facing up.
 - After installing the rings, they should rotate freely without sticking.

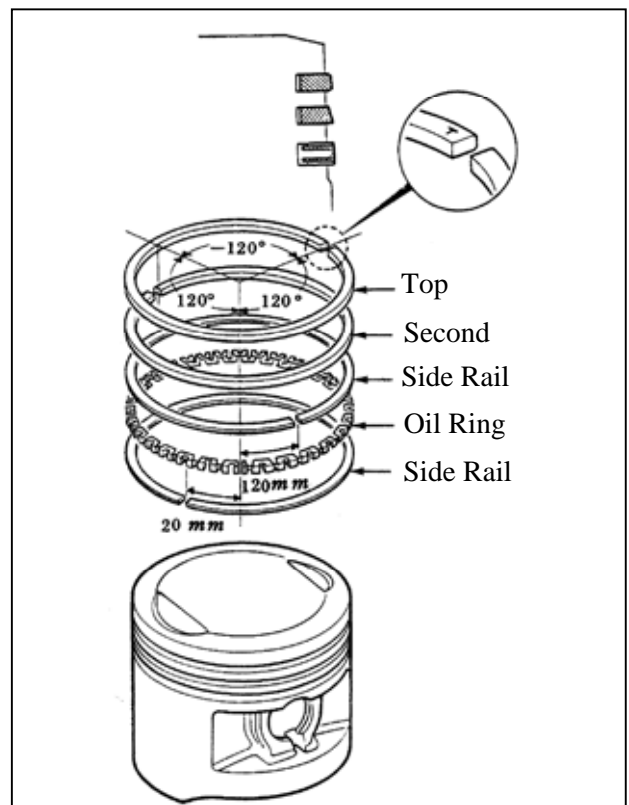

8. CYLINDER/PISTON

PISTON INSTALLATION

Remove any gasket material from the crankcase surface.

- * Be careful not to drop foreign matters into the crankcase.



Install the piston, piston pin and a new piston pin clip.

- *
 - Position the piston "IN" mark on the intake valve side.
 - Place a clean shop towel in the crankcase to keep the piston pin clip from falling into the crankcase.

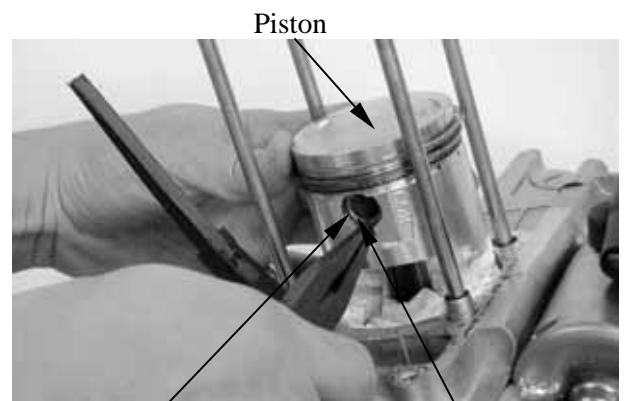

Piston Pin Clip

Piston Pin

CYLINDER INSTALLATION

Install the dowel pins and a new cylinder gasket on the crankcase.

Coat the cylinder bore, piston and piston rings with clean engine oil.

Carefully lower the cylinder over the piston by compressing the piston rings.

- *
 - Be careful not to damage or break the piston rings.
 - Stagger the ring end gaps at 120° to the piston pin.

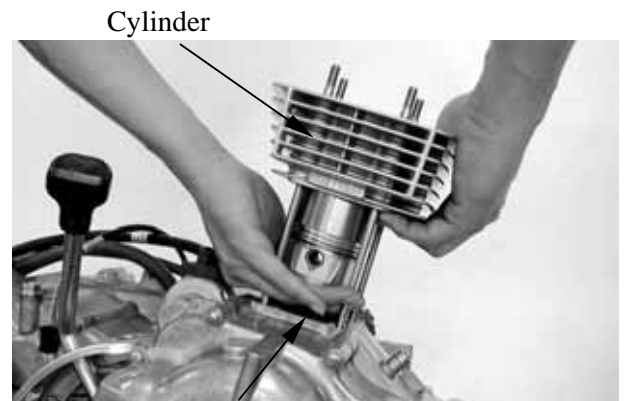

Gasket

Install the cam chain tension.
Tighten the cam chain tension bolts.



Bolts

9. DRIVE AND DRIVEN PULLEYS

DRIVE AND DRIVEN PULLEYS

SERVICE INFORMATION.....	9-2
TROUBLESHOOTING.....	9-2
LEFT CRANKCASE COVER	9-3
DRIVE PULLEY	9-3
CLUTCH/DRIVEN PULLEY	9-3



9. DRIVE AND DRIVEN PULLEYS

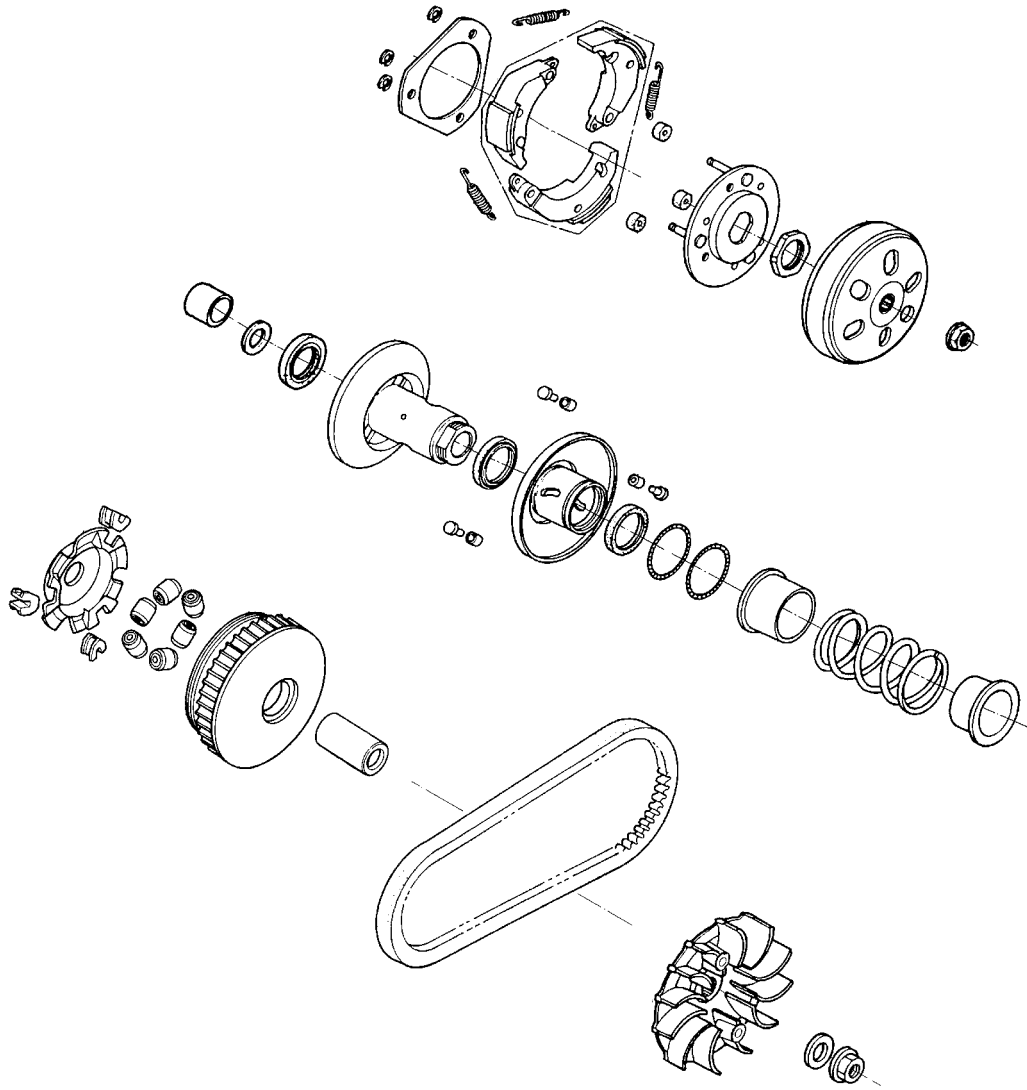

9. DRIVE AND DRIVEN PULLEYS

ATV 150/125

SERVICE INFORMATION

GENERAL INSTRUCTIONS

- The drive pulley, clutch and driven pulley can be serviced with the engine installed in the frame.
- Avoid getting grease and oil on the drive belt and pulley faces. Remove any oil or grease from them to minimize the slipping of drive belt and drive pulley.

SPECIFICATIONS

mm (in)

Item	Standard	Service Limit
Movable drive face bushing I.D.	27~27.021 (1.08~1.08084)	27.06 (1.0824)
Drive face collar O.D.	26.97~26.99 (1.0788~1.0796)	26.94 (1.0776)
Drive belt width	20~21 (0.8~0.84)	19 (0.76)
Clutch lining thickness	—	2 (0.08)
Clutch outer I.D.	130~130.2 (5.2~5.208)	130.5 (5.22)
Driven face spring free length	—	83.2 (3.328)
Driven face O.D.	33.965~33.485 (1.3586~1.3394)	33.94 (1.3576)
Movable driven face I.D.	34~34.025 (1.36~1.361)	34.06 (1.3624)
Weight roller O.D.	20.95~21.1 (0.828~0.844)	20.42 (0.8168)

TORQUE VALUES

Drive face nut	6 kgf-m (60 N-m, 43 lbf-ft)
Clutch outer nut	5.5 kgf-m (55 N-m, 40 lbf-ft)

SPECIAL TOOLS

Universal holder	E017	Clutch spring compressor	E027
Bearing puller	E008	Oil seal and bearing install	E014

TROUBLESHOOTING

Engine starts but motorcycle won't move

- Worn drive belt
- Broken ramp plate
- Worn or damaged clutch lining
- Broken driven face spring

Lack of power

- Worn drive belt
- Weak driven face spring
- Worn weight roller
- Fouled drive face

Engine stalls or motorcycle creeps

- Broken clutch weight spring

9. DRIVE AND DRIVEN PULLEYS

LEFT CRANKCASE COVER

REMOVAL

Loosen the drive belt air tube band screw.

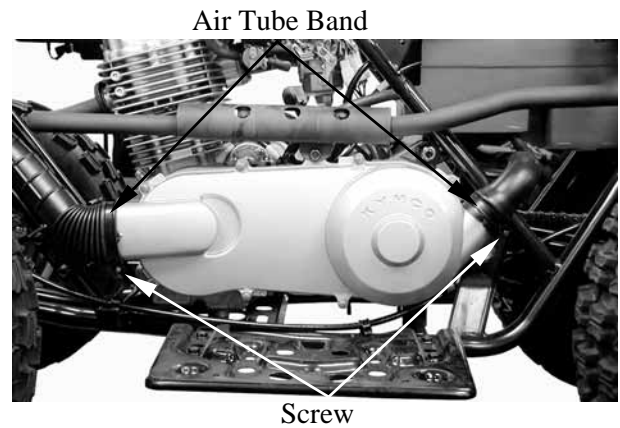

Remove the left crankcase cover bolts and left crankcase cover.
Remove the gasket and dowel pins.

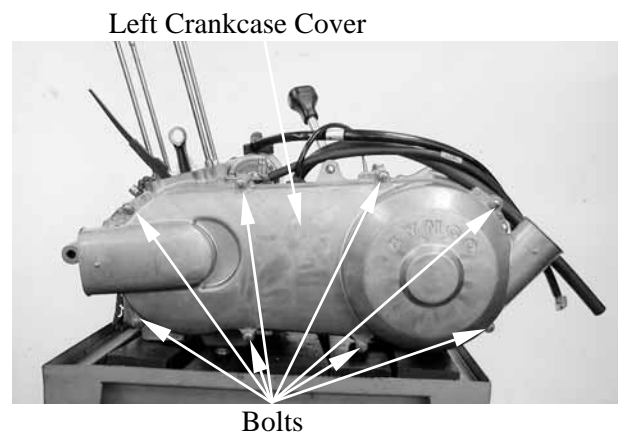

DRIVE PULLEY

REMOVAL

Hold the drive pulley using an universal holder and remove the drive face nut and starting ratchet.
Remove the drive pulley face.

Special tool:

Universal Holder E017

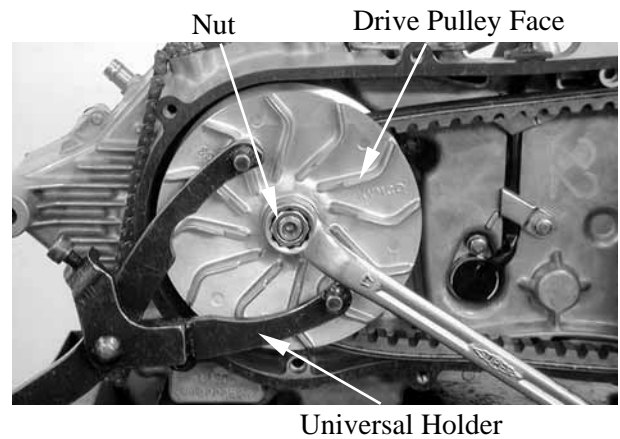

CLUTCH/DRIVEN PULLEY

Remove the drive pulley and drive belt.
Hold the clutch outer with the flywheel holder and remove the clutch outer nut.
Remove the clutch outer.
Remove the clutch/driven pulley and drive belt.

Special tool:

Universal Holder E017

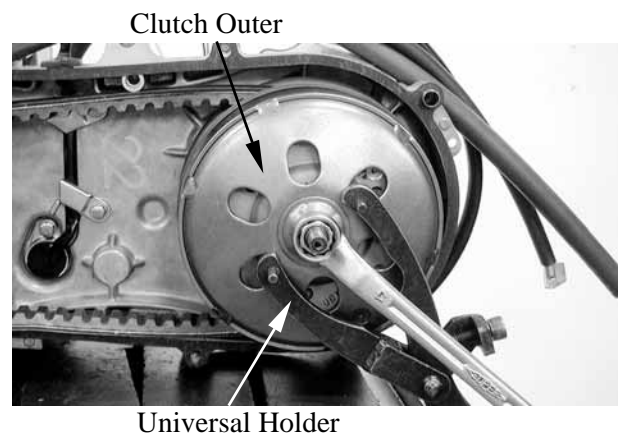

9. DRIVE AND DRIVEN PULLEYS

INSPECTION

Check the drive belt for cracks, separation or abnormal or excessive wear.
Measure the drive belt width.

Service Limit: 19 mm (0.76 in)

* Use specified genuine parts for replacement.

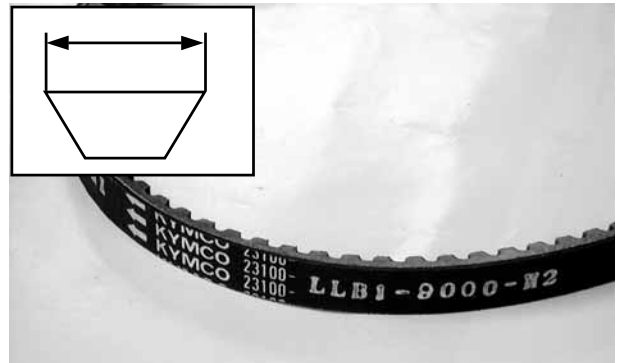

Remove the movable drive face assembly.
Remove the drive pulley collar.

Drive Pulley Collar

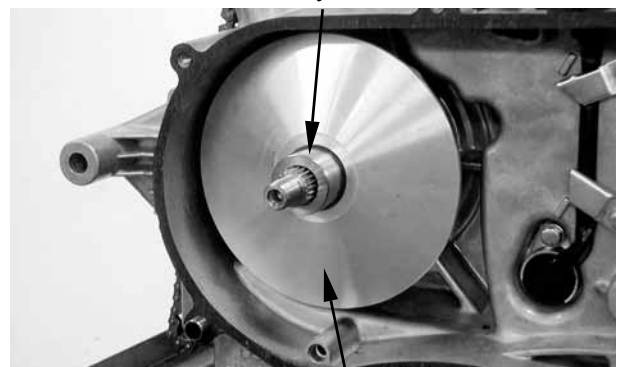

Movable Drive Face Assembly

DISASSEMBLY

Remove the ramp plate.

Ramp Plate



Remove the weight rollers.

Weight Rollers



9. DRIVE AND DRIVEN PULLEYS

INSPECTION

Check each weight roller for wear or damage.
Measure each weight roller O.D.

Service Limit: 20.42 mm (0.8168 in).



Measure the movable drive face bushing I.D.

Service Limit: 27.06 mm (1.0824 in)



Check the drive pulley bushing for wear or damage.
Measure the O.D. of the drive pulley bushing sliding surface.

Service Limit: 26.94 mm (1.0776 in)

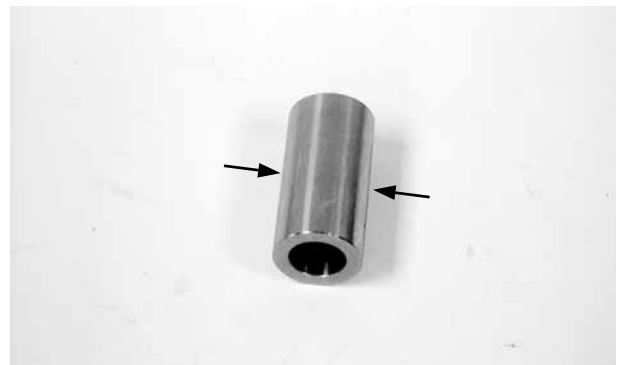

9. DRIVE AND DRIVEN PULLEYS

ASSEMBLY

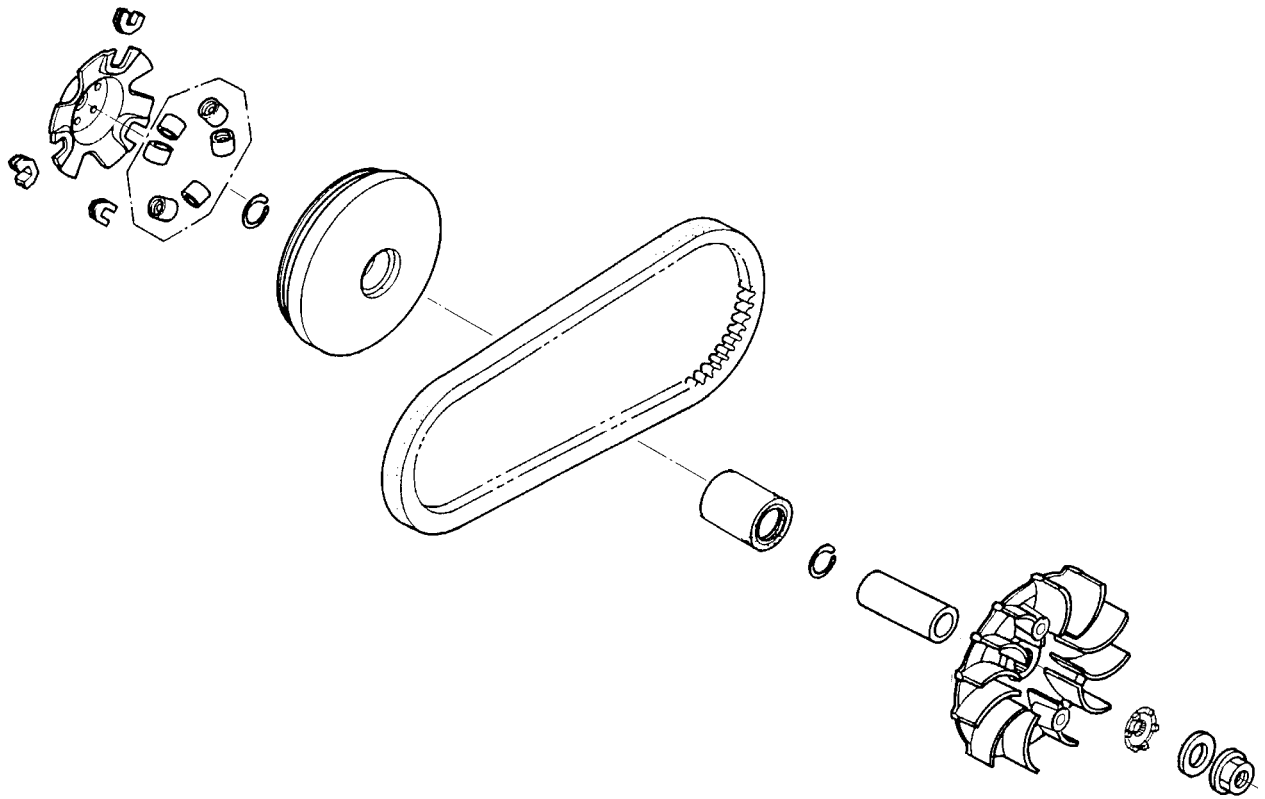

Install the weight rollers into the movable drive face.



Weight Roller

Install the ramp plate.



Ramp Plate

9. DRIVE AND DRIVEN PULLEYS

Insert the drive pulley collar into the movable drive face.

Drive Pulley Collar



INSTALLATION

Install the movable drive face onto the crankshaft.



Movable Drive Face Assembly

INSPECTION

Inspect the clutch outer for wear or damage.
Measure the clutch outer I.D.

Service Limit: 130.5 mm (5.22 in)

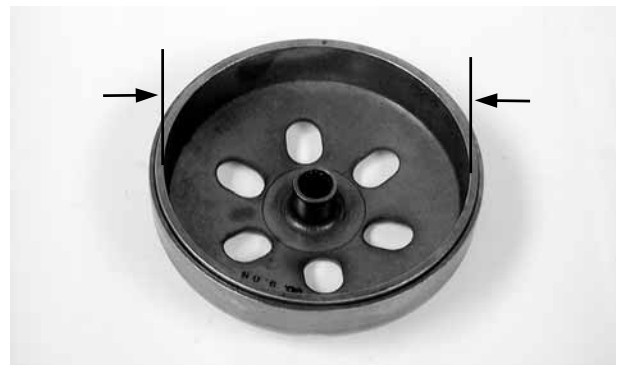

CLUTCH/DRIVEN PULLEY DISASSEMBLY

Clutch

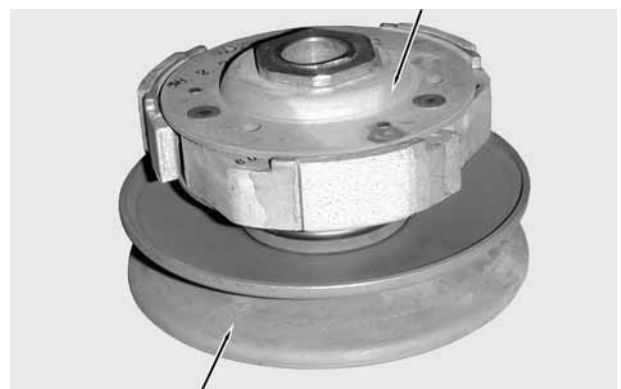

Driven Pulley

9. DRIVE AND DRIVEN PULLEYS

Hold the clutch/driven pulley assembly with the clutch spring compressor.

* Be sure to use a clutch spring compressor to avoid spring damage.

Special tool:

Clutch Spring Compressor E027

Set the clutch spring compressor in a vise and remove the clutch drive plate nut.

Loosen the clutch spring compressor and disassemble the clutch/driven pulley assembly. Remove the seal collar.

Check the driven face for wear or damage. Measure the clutch lining thickness.

Service Limit: 2 mm (0.08 in)

Pull out the guide roller pins and guide rollers. Remove the movable driven face from the driven face.

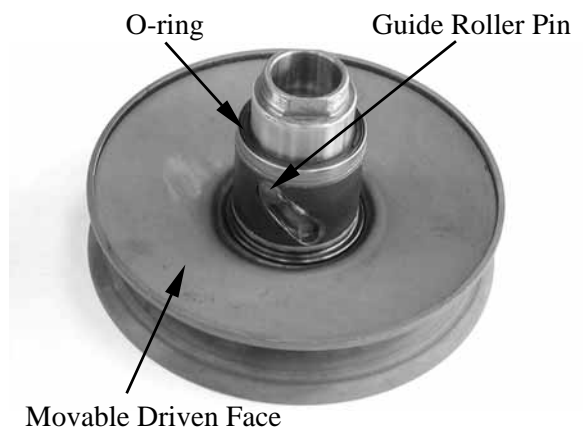
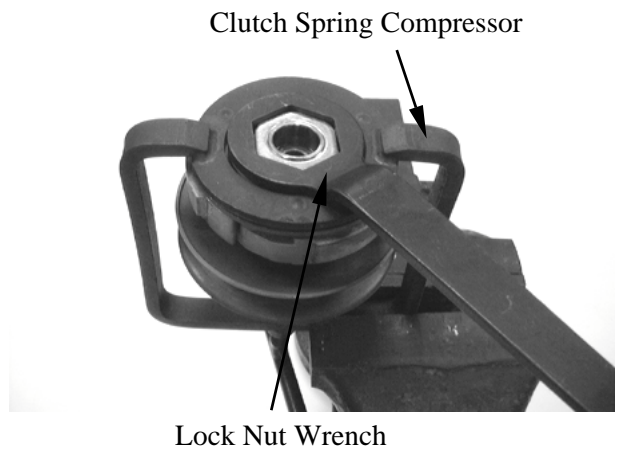

9. DRIVE AND DRIVEN PULLEYS

Remove the oil seal from the movable driven face.



INSPECTION

Measure the driven face spring free length.

Service Limit: 83.2 mm (3.328 in)

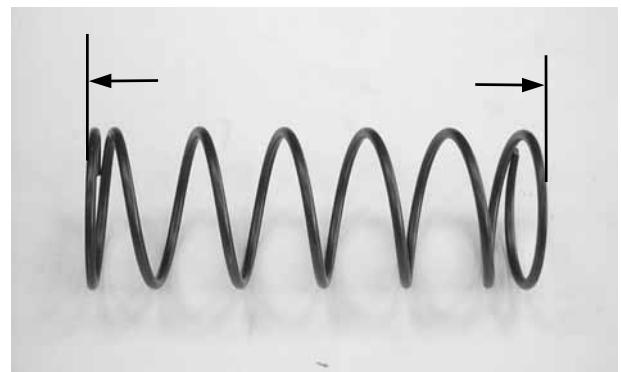

Check the driven face for wear or damage.
Measure the driven face O.D.

Service Limit: 33.94 mm (1.3576 in)



Check the movable driven face for wear or damage.

Measure the movable driven face I.D.

Service Limit: 34.06 mm (1.3624 in)

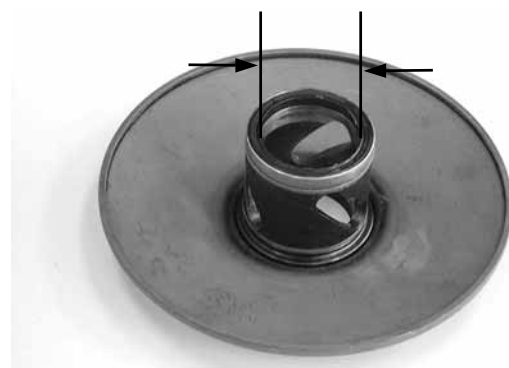

9. DRIVE AND DRIVEN PULLEYS

DRIVEN PULLEY FACE BEARING REPLACEMENT

Drive the inner needle bearing out of the driven pulley face.

- * Discard the removed bearing and replace with a new one.



Remove the snap ring and drive the outer bearing out of the driven face.

- * Discard the removed bearing and replace with a new one.



Apply grease to the outer bearing. Drive a new outer bearing into the driven face with the sealed end facing up.

Special tool:

Bearing Puller E008

Seat the snap ring in its groove. Apply grease to the driven face bore areas.

- * Pack all bearing cavities with 9~9.5g grease.
Specified grease: Heat resistance 230°C

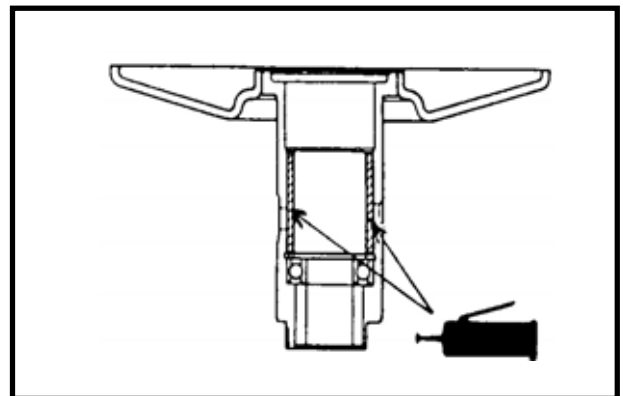

Press a new needle bearing into the driven face.

Special tool:

Oil Seal And Bearing Install E014

CLUTCH DISASSEMBLY

Remove the circlips and retainer plate to disassemble the clutch.

- * Keep grease off the clutch linings.

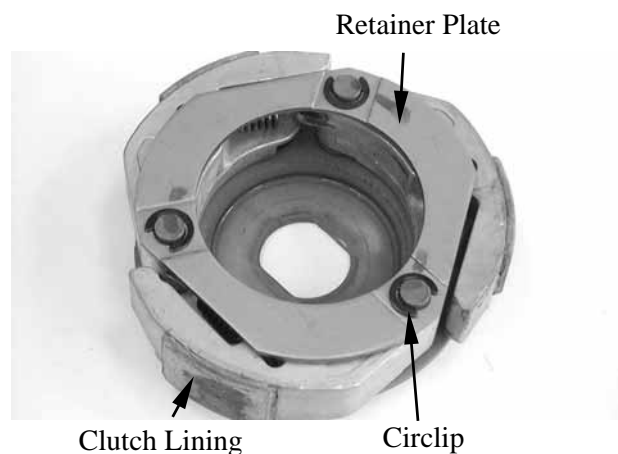

9. DRIVE AND DRIVEN PULLEYS

Install the damper rubbers on the drive plate pins.
 Install the clutch weights/shoes and clutch springs onto the drive plate.
 Install the retainer plate and secure with the circlips.

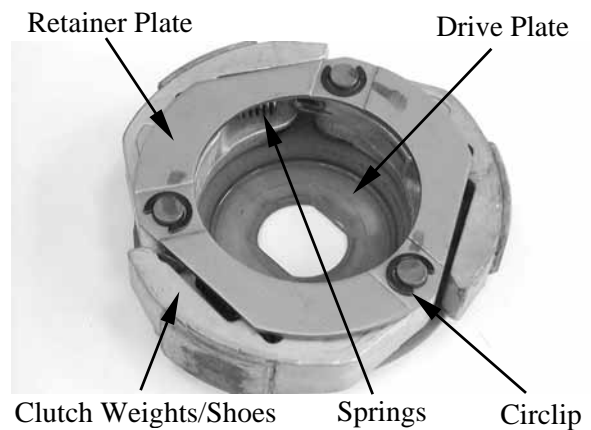

CLUTCH/DRIVEN PULLEY ASSEMBLY

Clean the driven pulley faces and remove any grease from them.
 Install the oil seal onto the moveable driven face.
 Apply grease to the Oil seal and install them onto the moveable driven face.

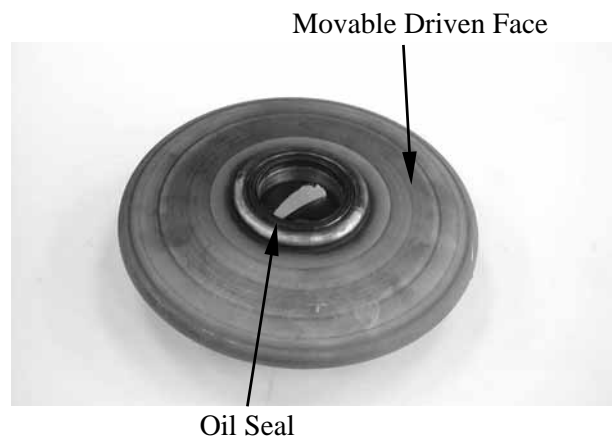

Install the movable driven face onto the driven face.
 Apply grease to the guide rollers and guide roller pins and then install them into the holes of the driven face.

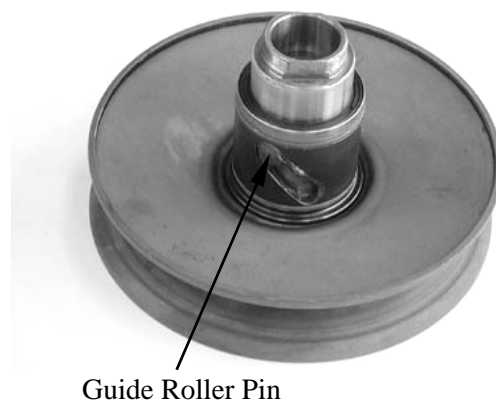

Install the seal collar.
 Remove any excessive grease.

* Be sure to clean the driven face off any grease.

Set the driven pulley assembly, driven face spring and clutch assembly onto the clutch spring compressor.

* Align the flat surface of the driven face with the flat on the clutch drive plate.

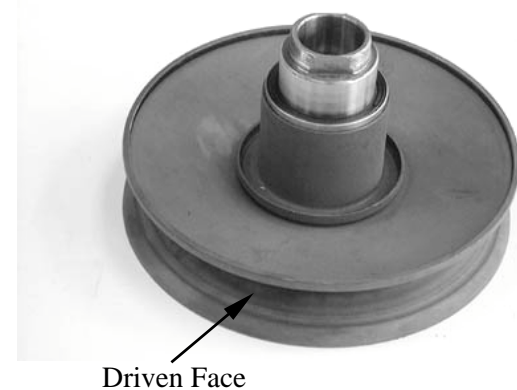

9. DRIVE AND DRIVEN PULLEYS

Compress the clutch spring compressor and install the drive plate nut.
Set the clutch spring compressor in a vise and tighten the drive plate nut to the specified torque.

Torque: 5.5 kgf-m (55 N-m, 40 lbf-ft)

* Be sure to use a clutch spring compressor to avoid spring damage.

Special tool:

Clutch Spring Compressor E027

INSTALLATION

Install the clutch/driven pulley onto the drive shaft.

* Keep grease off the drive shaft.

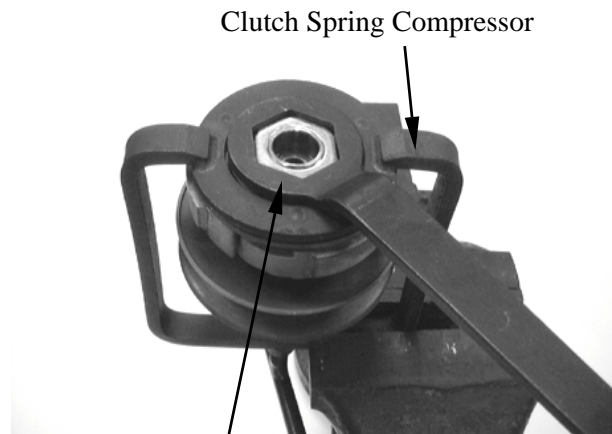

Clutch Spring Compressor
Lock Nut Wrench Clutch



Driven Pulley

Install the clutch outer.
Hold the clutch outer with the flywheel holder.

Install and tighten the clutch outer nut.

Torque: 5.5 kgf-m (55 N-m, 40 lbf-ft)

Special tool:

Universal Holder E017

Install the drive belt.

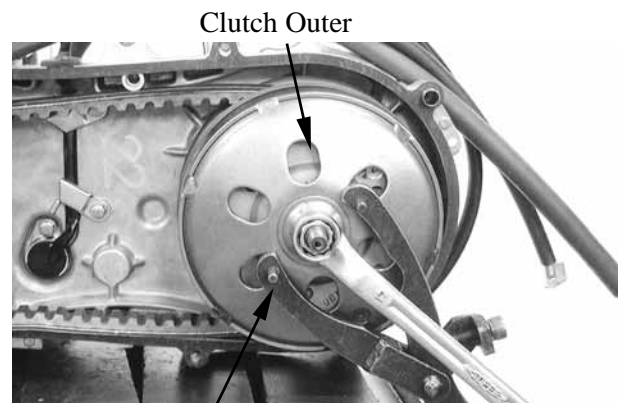

Clutch Outer
Universal Holder

Install the drive pulley face, starting ratchet and drive face nut.

* When installing the drive pulley face, compress it to let the drive belt move downward to the lowest position so that the drive pulley can be tightened.
Install the starting ratchet by aligning the starting ratchet teeth with the crankshaft teeth.
Do not get oil or grease on the drive belt or pulley faces.

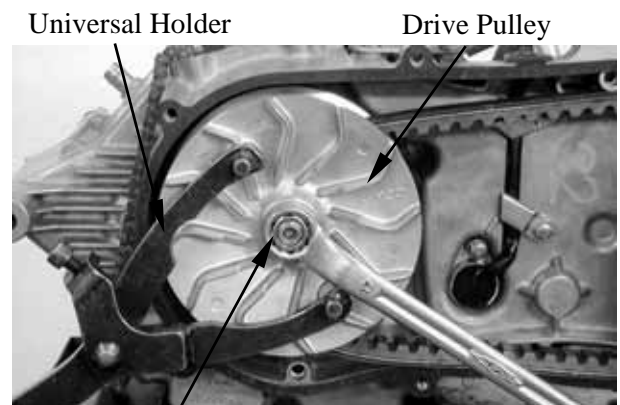

Universal Holder Drive Pulley

Nut

Torque: 6 kgf-m (60 N-m, 43 lbf-ft)

9. DRIVE AND DRIVEN PULLEYS

Install the left crankcase cover and tighten the cover bolts diagonally.
Connect the drive belt air tube and tighten the band screw.

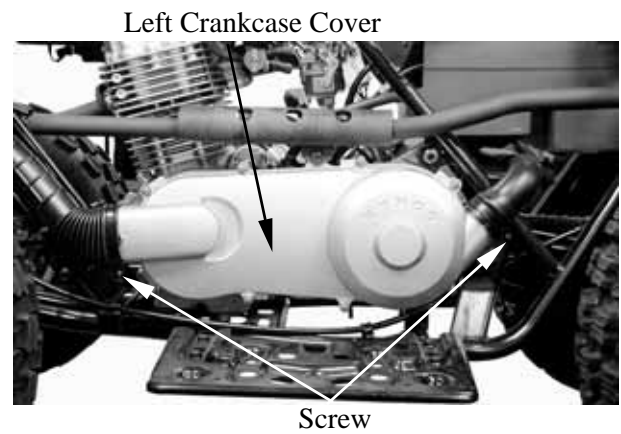

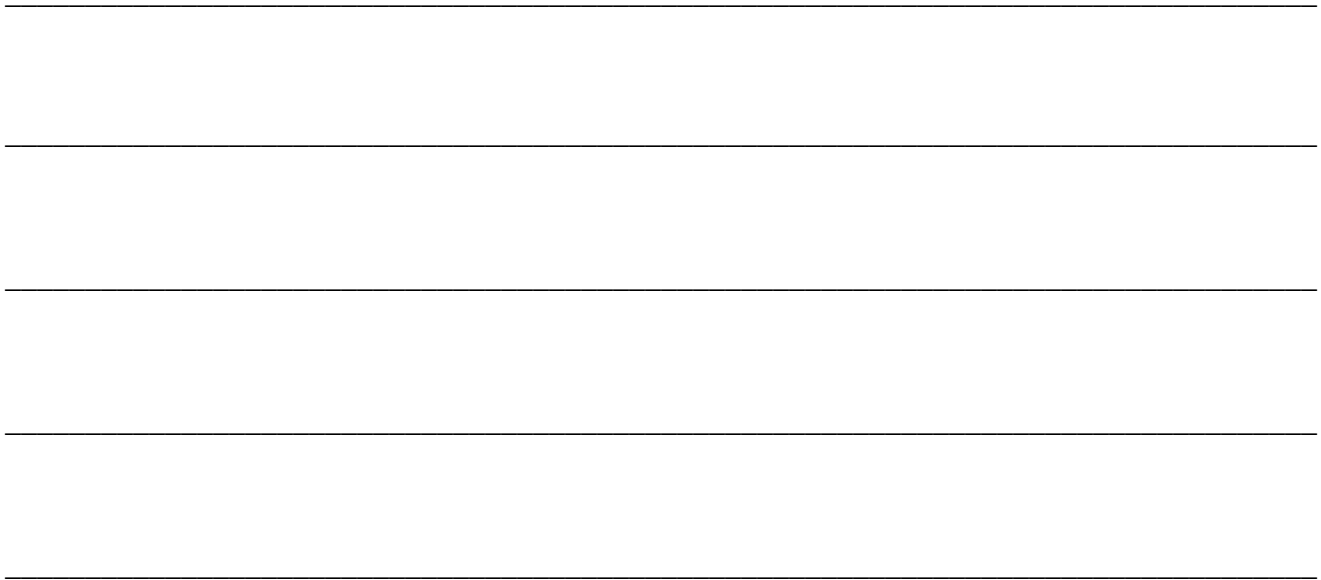

FINAL REDUCTION/TRANSMISSION SYSTEM

SERVICE INFORMATION----- 10- 2
TROUBLESHOOTING----- 10- 2
FINAL REDUCTION DISASSEMBLY ----- 10- 3
FINAL REDUCTION/TRANSMISSION INSPECTION ----- 10- 5
TRANSMISSION GEARS REMOVAL----- 10- 7
FINAL REDUCTION INSTALLATION ----- 10- 8

10. FINAL REDUCTION/ TRANSMISSION SYSTEM

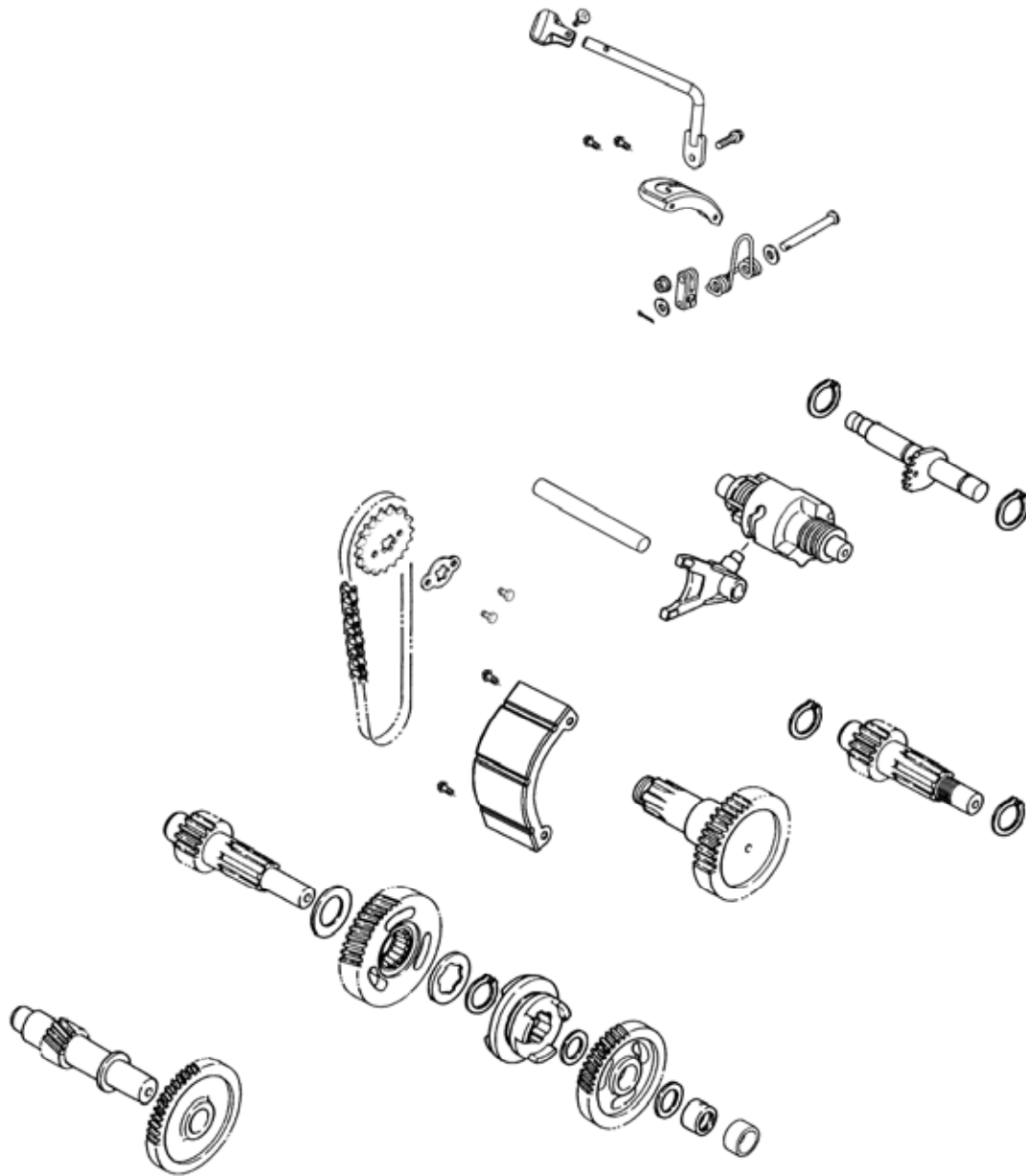

SERVICE INFORMATION

GENERAL INSTRUCTIONS

- When replacing the drive shaft, use a special tool to hold the bearing inner race for this operation.

SPECIFICATIONS

Specified Oil: GEAR OIL SAE 90#

Oil Capacity:

- At disassembly : 400 cc (0.352 Imp qt, 0.424 US qt)
- At change : 200 cc (0.176 Imp qt, 0.212 US qt)

SPECIAL TOOLS

Flywheel holder	E021
Flywheel puller	E005
Lock nut socket wrench	E009

TROUBLESHOOTING

Engine starts but motorcycle won't move

- Damaged transmission
- Seized or burnt transmission

Oil leaks

- Oil too rich
- Worn or damaged oil seal

10. FINAL REDUCTION/ TRANSMISSION SYSTEM

FINAL REDUCTION DISASSEMBLY

Drain engine oil and transmission gear oil into a clean container.
Remove the engine.
Remove the right crankcase cover.



Bolts

Remove the flywheel, starter clutch and starter idle gear (refer to chapter 4).

(MX' er 150/125: Remove the two bolt from the shift guide and the bolt from the drive select lever, then remove the shift guide and drive select lever.)

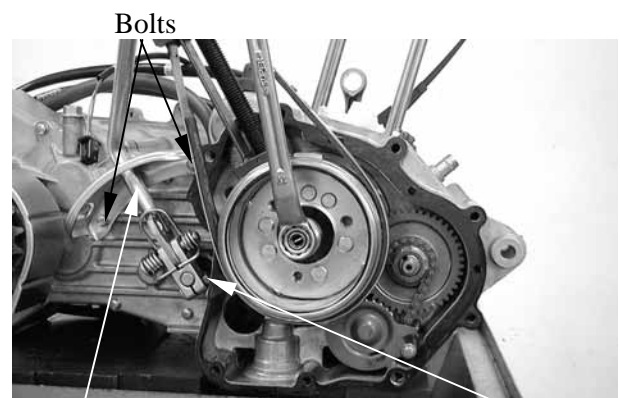

Drive Select Lever/Shift Guide

Bolt

Remove the oil pump (refer to chapter 4).

Remove the nut (**Left threaded**) and washer from the balancer gear using the special tool, then remove oil drive gear, balancer gear, woodruff key **and washer**.

Special tool:

Lock nut wrench: E010

Remove the washer and crankshaft gear.

Nut/Washer/Oil Drive Gear/Balancer Gear/Washer

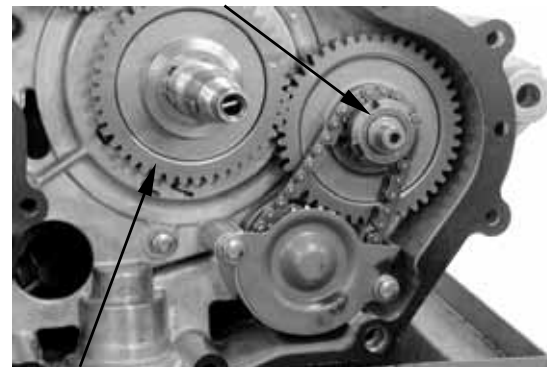

Washer/Crankshaft Gear

10. FINAL REDUCTION/ TRANSMISSION SYSTEM

Remove the left case bolt.

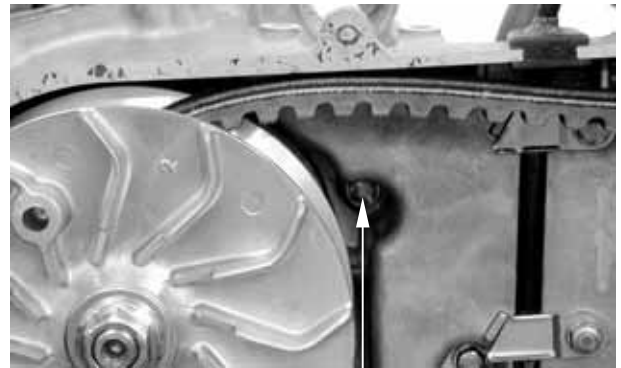

Bolt

Remove the transmission case cover
attaching bolts.

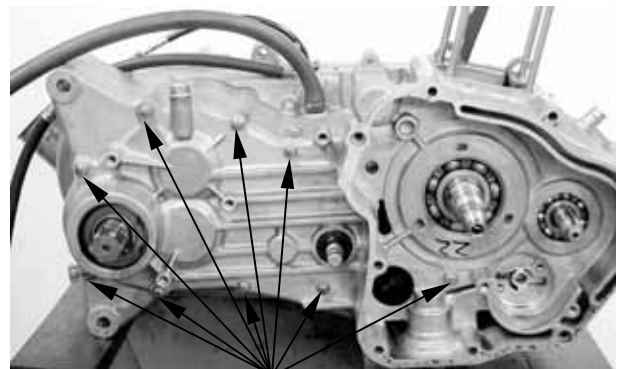

Bolt

Remove gasket and two dowel pins.



Dowel Pins

10. FINAL REDUCTION/ TRANSMISSION SYSTEM

FINAL REDUCTION/ TRANSMISSION INSPECTION

Inspect the change gear shaft for wear, damage or seizure.

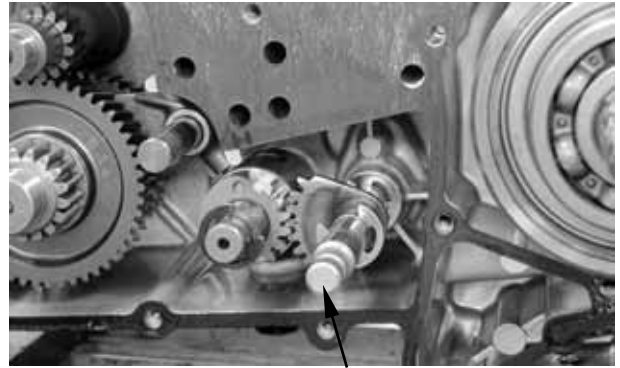

Change Gear Shaft

Check the transmission operation.
Repair if unsmooth operation.

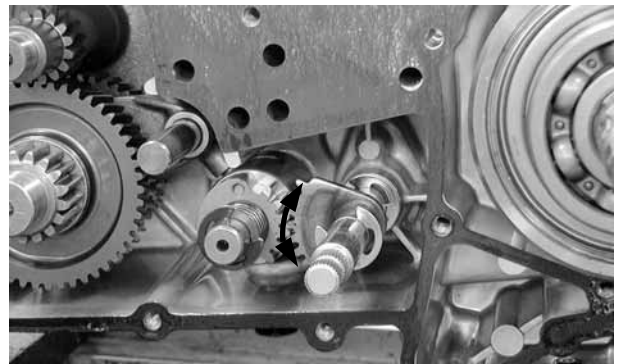

Remove the plug.



10. FINAL REDUCTION/ TRANSMISSION SYSTEM

Remove spring, washer and shift cam stopper.

Shift Cam Stopper

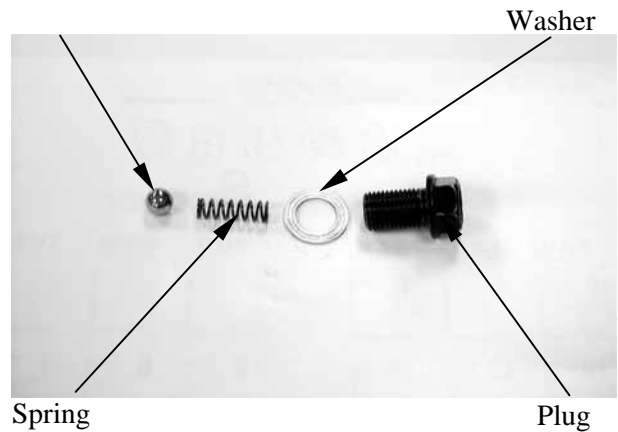

Remove the transmission fork shaft and transmission fork.

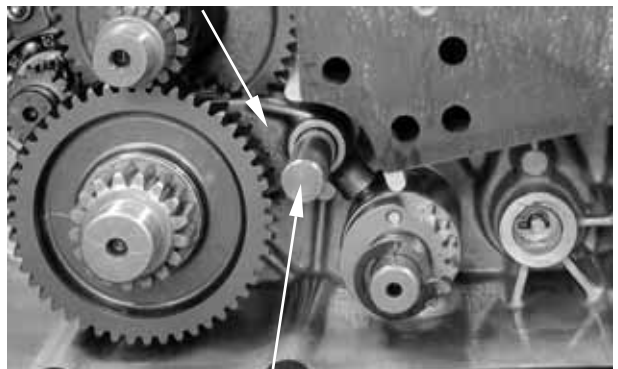

Measure the guide bar runout.
Out of specification → Replace.

Service Limit:
Less than 0.03 mm (0.0012 in)

* Do not attempt to straighten a bent guide bar.

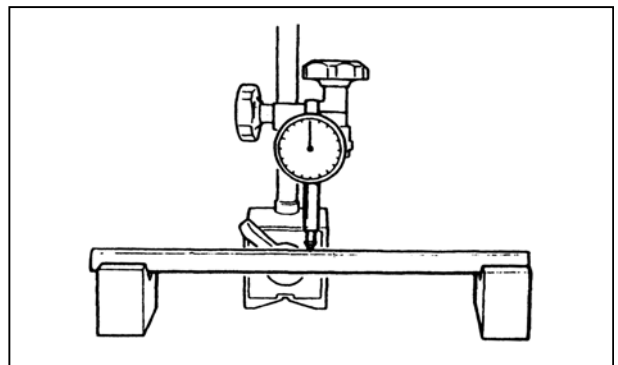

Check the shift cam groove and shift cam gear.
Wear or damage → Replace.

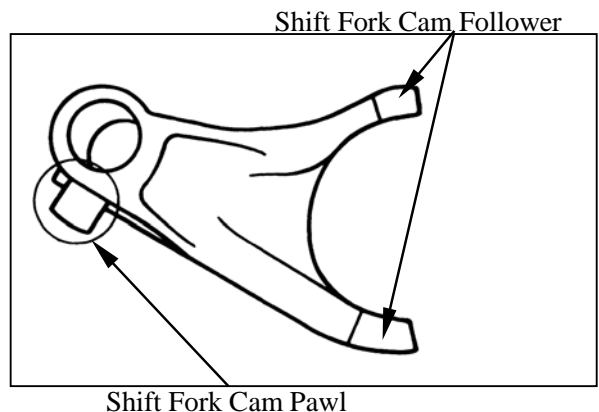

10. FINAL REDUCTION/ TRANSMISSION SYSTEM

Check the shift cam groove and shift cam gear.

Replace if wear or damage.



TRANSMISSION GEARS REMOVAL

Remove the final gear and main shaft.

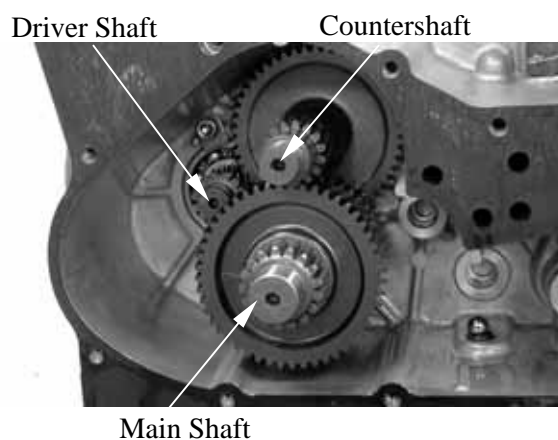

GEAR/SHAFT COLLAR INSPECTION

Check each gear and gear teeth for wear, damage, or poor lubrication.



Remove the counter shaft.

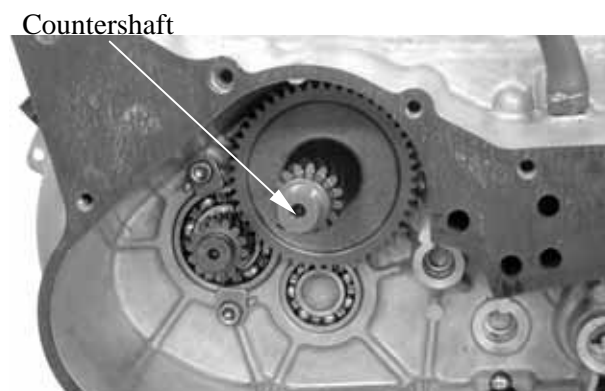

10. FINAL REDUCTION/ TRANSMISSION SYSTEM

FINAL REDUCTION INSPECTION

Inspect the countershaft and gear for wear or damage.



Inspect the drive shaft and gear for wear or damage.
Check the left crankcase bearings for excessive play and inspect the oil seal for wear or damage.

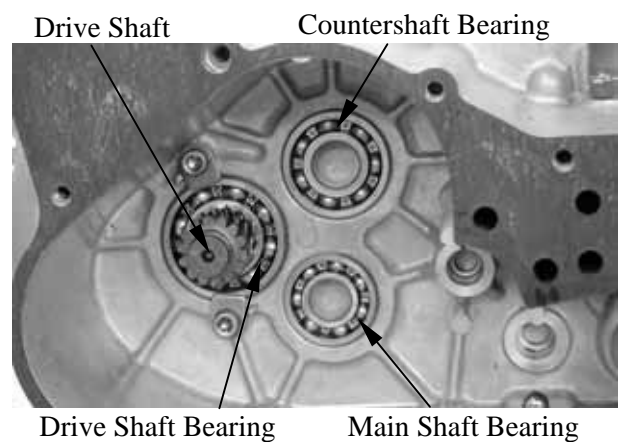

Inspect the final shaft gear for wear or damage.
Check the right crankcase bearings for excessive play and inspect the oil seal for wear or damage.

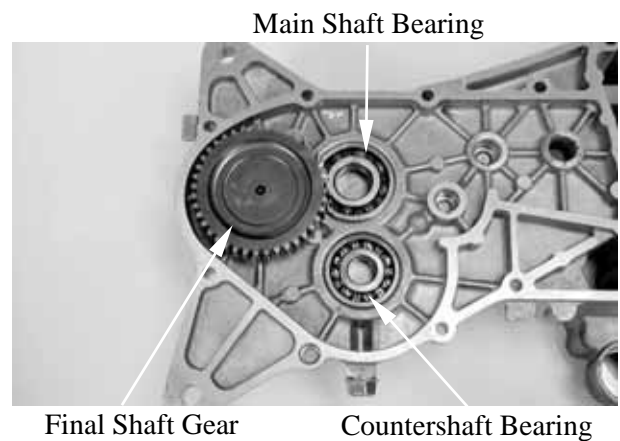

FINAL REDUCTION INSTALLATION

Install the final gear and final shaft into the left crankcase.
Install the countershaft and gear into the left crankcase.
Install the main shaft and gear into the left crankcase.



10. FINAL REDUCTION/ TRANSMISSION SYSTEM

Install the shift cam into the left crankcase.
Install the transmission fork to the main shaft gear and install the transmission fork guide pin into the shift cam groove.

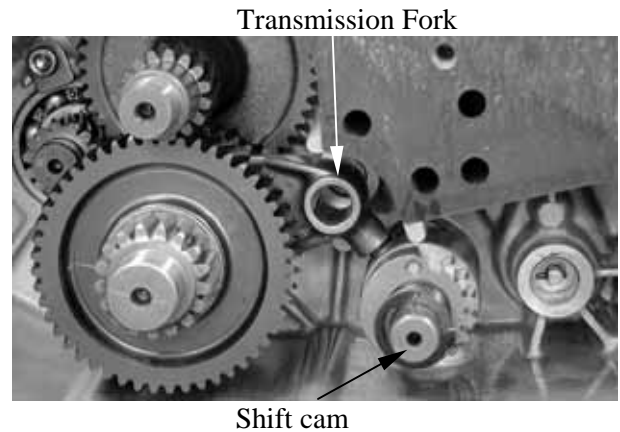

Install the transmission fork shaft into the left crankcase.

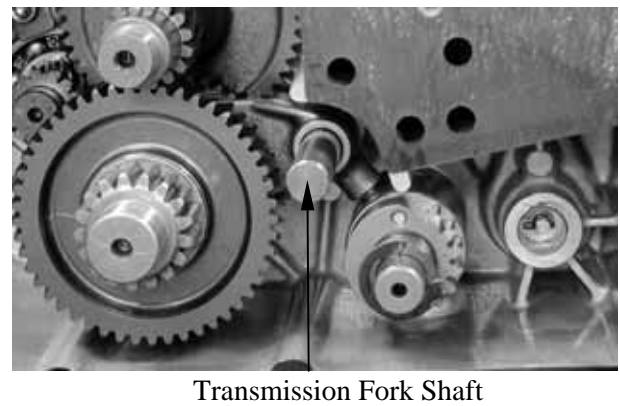

Install the change gear shaft by aligning the punch mark between with the punch mark of the shift cam gear.

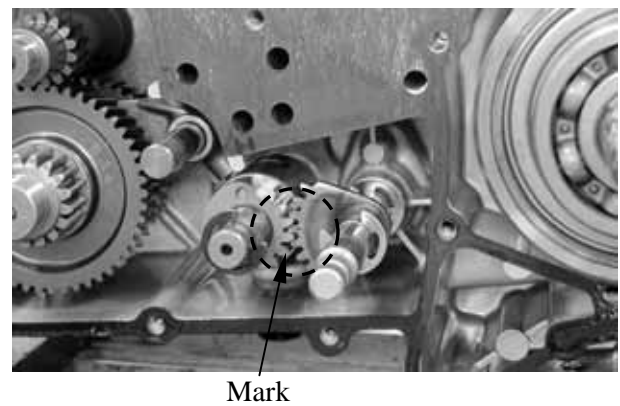

Install shift cam stopper, spring, washer and plug and tighten the plug.



10. FINAL REDUCTION/ TRANSMISSION SYSTEM

Install the dowel pins and a new gasket onto the right crankcase.

Tighten the crankcase attaching bolts.

Torque: 1 kgf-m (10 N-m, 7.2 lbf-ft)

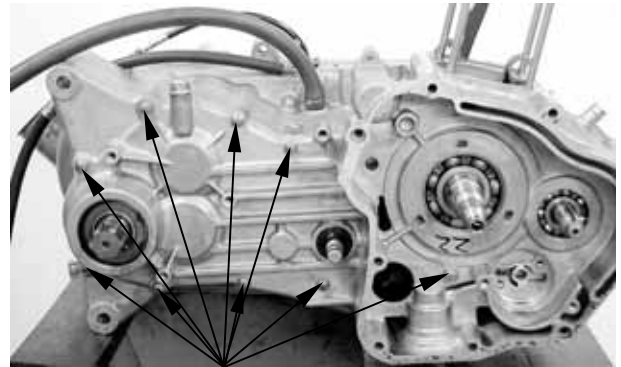

Bolts

Tighten the left crankcase attaching bolt.



Bolts

Install the crankshaft gear and washer.

- * Make sure the "INSIDE" mark on the washer facing the right crankcase.

Install the **washer**, balancer gear, woodruff key, oil drive gear, washer and nut, then tighten the nut (**Left threaded**) to specified torque using the special tool.

Torque: 4.5 kgf-m (45 N-m, 32 lbf-ft)

Special tool:

Lock nut wrench: E010

- *
 - Align the mark on the balancer gear with the mark on the crankshaft gear.
 - **Make sure the marks on the balancer gear and crankshaft gear facing out.**

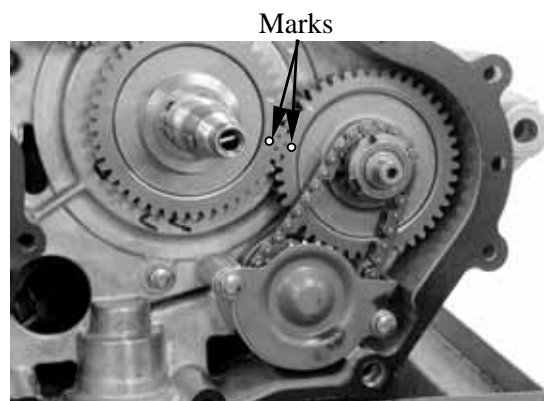

Install the oil pump (refer to chapter 4)

10. FINAL REDUCTION/ TRANSMISSION SYSTEM

Install the shift guide and drive select lever..

Install the starter idle gear starter clutch and flywheel (refer to chapter 4).

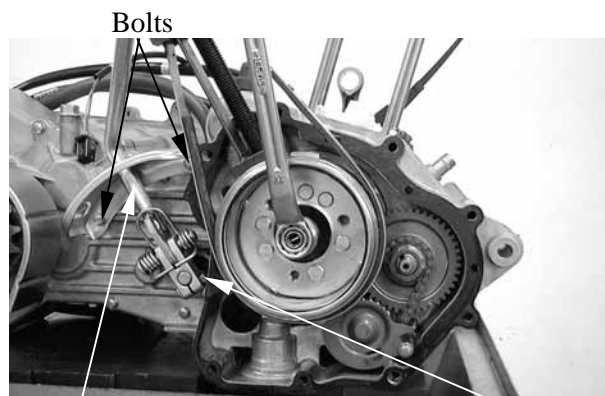

Drive Select Lever/Shift Guide

Install and tighten the right case cover bolt.

Specified Gear Oil:

KYMCO SIGMA GEAR OIL 90#

Oil Capacity:

At disassembly:

400 cc (0.352 Imp qt, 0.424 US qt)

At change:

200 cc (0.176 Imp qt, 0.212 US qt)

Install and tighten the oil check bolt.

Torque: 1 kgf-m (10 N-m, 7.2 lbf-ft)

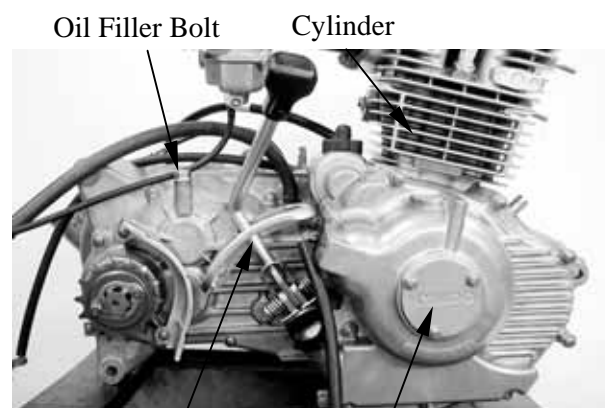

Shift Gear Spindle

Right Case Cover

11. CRANKSCASE/CRANKSHAFT/ BALANCE SHAFT

ATV 150/125

CRANKCASE/CRANKSHAFT/BALANCE SHAFT

SERVICE INFORMATION-----	11- 2
TROUBLESHOOTING-----	11- 2
CRANKCASE SEPARATION -----	11- 3
CRANKSHAFT INSPECTION-----	11- 4
CRANKCASE/BALANCE SHAFT ASSEMBLY-----	11- 5

11. CRANKCASE/CRANKSHAFT/ BALANCE SHAFT

ATV 150/125

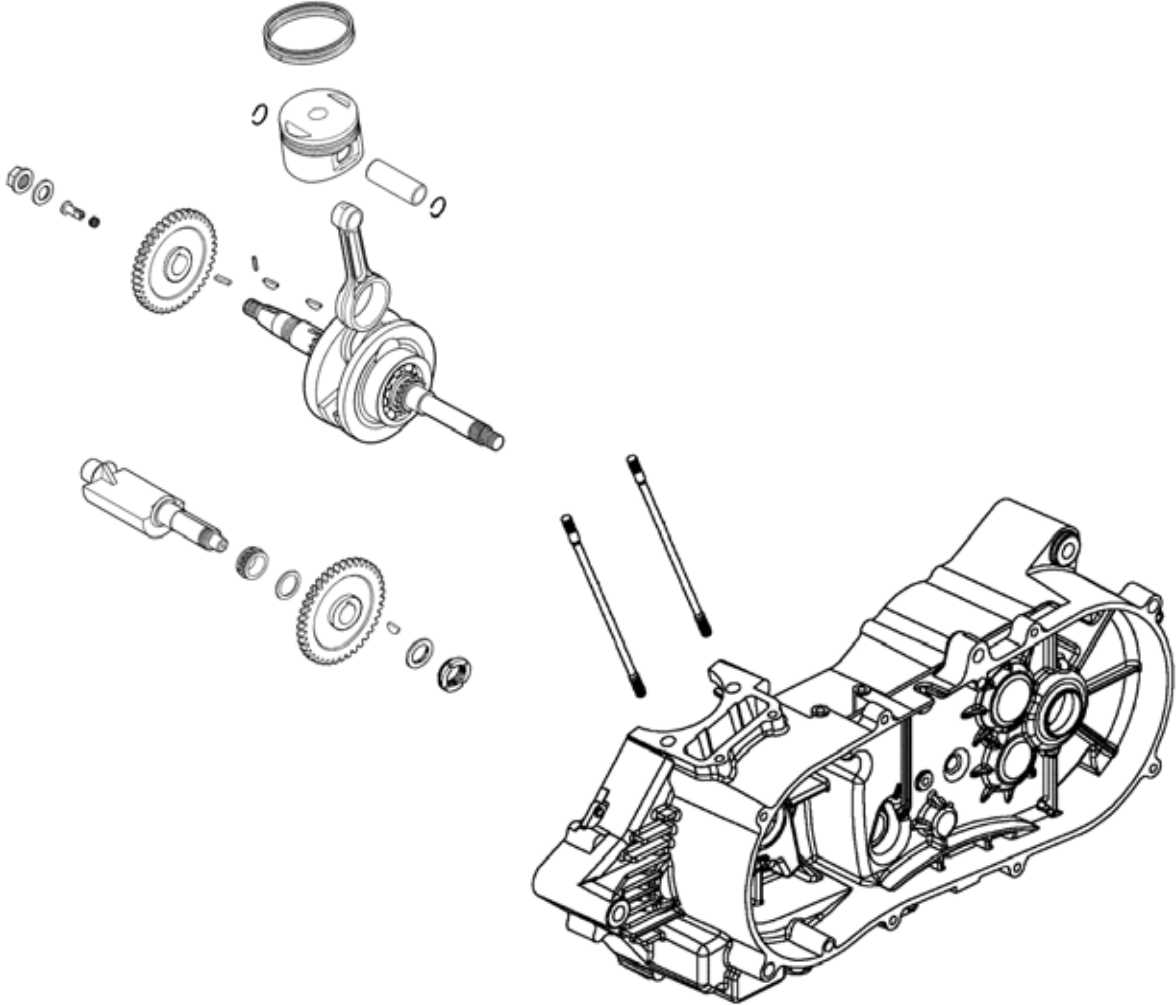

11. CRANKCASE/CRANKSHAFT/ BALANCE SHAFT

ATV 150/125

SERVICE INFORMATION

GENERAL INSTRUCTIONS

- This section covers crankcase separation to service the crankshaft. The engine must be removed for this operation.
- The following parts must be removed before separating the crankcase.
 - Cylinder head (Chapter 7)
 - Cylinder/piston (Chapter 8)
 - Drive and driven pulleys (Chapter 9)
 - A.C. generator (Chapter 4)
 - Carburetor/air cleaner (Chapter 5)
 - Starter motor (Chapter 16)
 - Oil pump (Chapter 4)

SPECIFICATIONS

mm (in)

	Item	Standard	Service Limit
Crankshaft	Connecting rod big end side clearance	0.1 ~ 0.35 (0.004 ~ 0.014)	0.55 (0.022)
	Connecting rod big end radial clearance	0 ~ 0.008 (0 ~ 0.00032)	0.05 (0.002)
	Run out	—	0.1 (0.004)

TORQUE VALUES

Crankcase bolt	1 kgf-m (10 N-m, 7.2 lbf-ft)
Cam chain tensioner slipper bolt	1 kgf-m (10 N-m, 7.2 lbf-ft)
Cam chain cover bolt	1 kgf-m (10 N-m, 7.2 lbf-ft)

TROUBLESHOOTING

Excessive engine noise

Excessive bearing play

11. CRANKCASE/CRANKSHAFT/ BALANCE SHAFT

ATV 150/125

CRANKCASE SEPARATION

Remove the left and right crankcase attaching bolts. (Refer to chapter 10)
Separate the left and right crankcase halves.

* Do not damage the crankcase gasket surface.

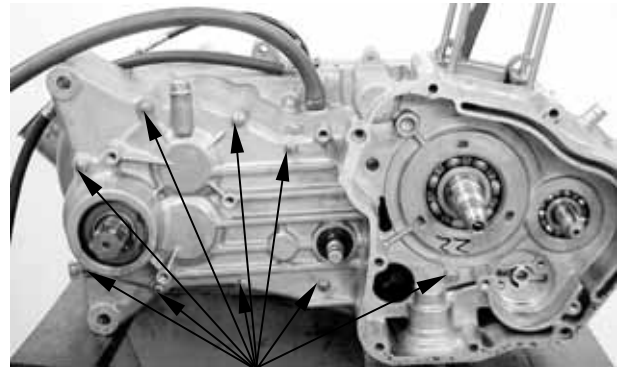

Crankcase Bolts

Remove the gasket and dowel pins.

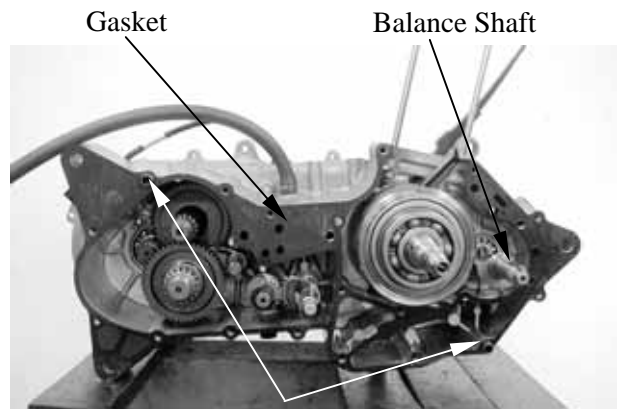

Dowel Pins

Remove balance shaft from the left crankcase.

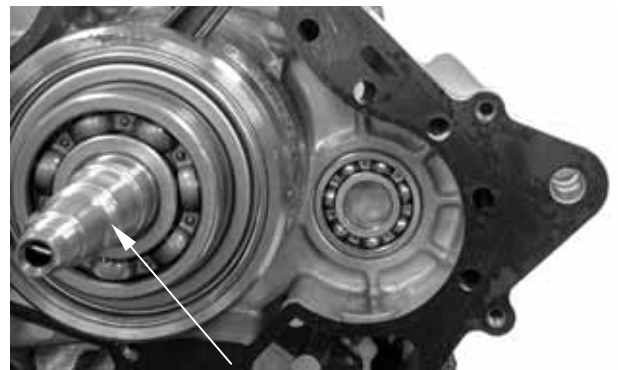

Crankshaft

11. CRANKCASE/CRANKSHAFT/ BALANCE SHAFT

ATV 150/125

Remove the crankshaft and cam chain from the left crankcase.



Clean off all gasket material from the crankcase mating surfaces.

* Avoid damaging the crankcase mating surfaces.

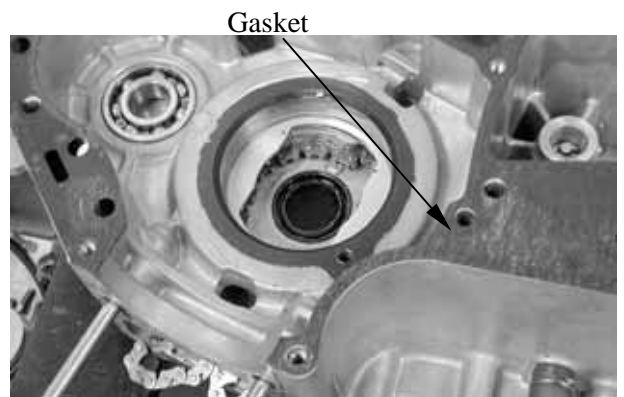

CRANKSHAFT INSPECTION

Measure the connecting rod small end I.D.

Service Limit: 15.06 mm (0.6024 in)

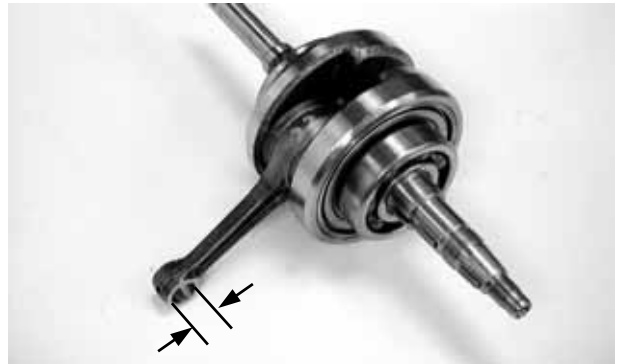

Measure the connecting rod big end side clearance.

Service Limit: 0.55 mm (0.022 in)



11. CRANKCASE/CRANKSHAFT/ BALANCE SHAFT

ATV 150/125

Turn the crankshaft bearings and check for excessive play.
Measure the crankshaft bearing play.

Service Limit:

- Axial : 0.2 mm (0.008 in)
- Radial : 0.05 mm (0.002 in)

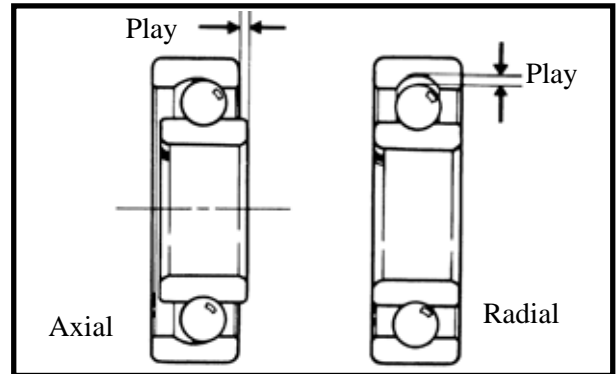

Measure the crankshaft run out.
Service Limit: 0.1 mm (0.004 in)

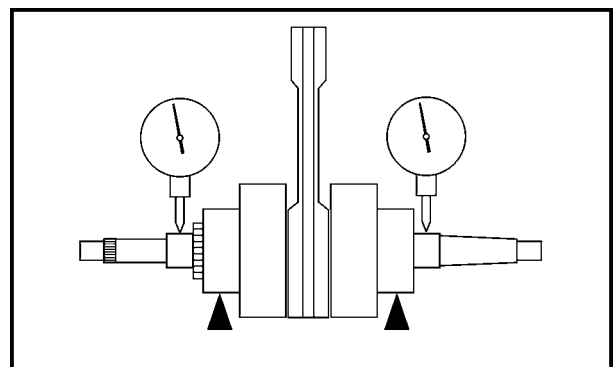

CRANKCASE/BALANCE SHAFT ASSEMBLY

Install the cam chain into the left crankcase.
Install the crankshaft and balance shaft into the left crankcase.

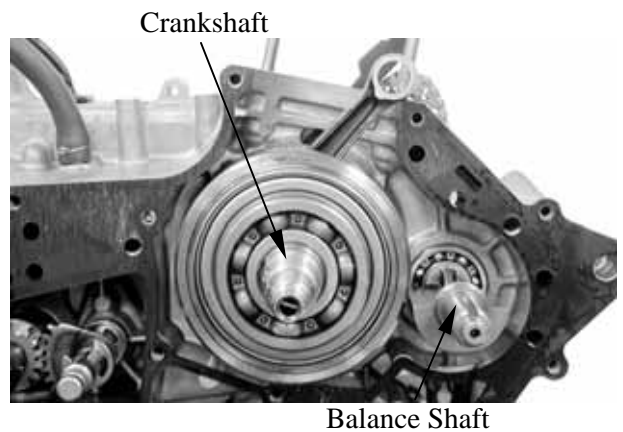

Install the right and left crankcase (page 10-10).
Tighten crankcase attach bolts.

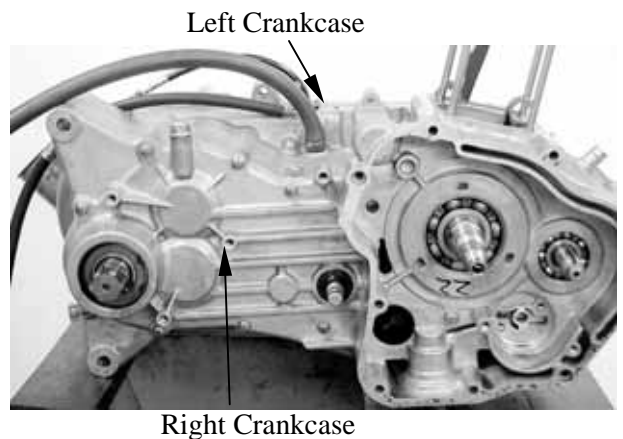

11. CRANKSCASE/CRANKSHAFT/ BALANCE SHAFT

ATV 150/125

Align the mark on the balance gear with the mark on the crankshaft gear.



Install the right and left case cover.



Install the cylinder.



**FRONT WHEEL/FRONT BRAKE/
FRONT SUSPENSION\STEERING SYSTEM**

SERVICE INFORMATION-----	12- 2
TROUBLESHOOTING-----	12- 3
FRONT WHEEL-----	12- 4
FRONT BRAKE -----	12- 7
FRONT SUSPENSION -----	12- 9
STEERING SYSTEM-----	12-13

12. FRONT WHEEL/FRONT BRAKE/FRONT SUSPENSION/STEERING SYSTEM



12. FRONT WHEEL/FRONT BRAKE/FRONT SUSPENSION/STEERING SYSTEM

SERVICE INFORMATION

GENERAL INSTRUCTIONS

- Remove the machine frame covers before removing the front wheel. Jack the machine front wheel off the ground and be careful to prevent the machine from falling down.
- During servicing, keep oil or grease off the brake drum and brake linings.
- Inspect the brake system before riding.

SPECIFICATIONS

mm (in)

Item		Standard	Service Limit
Front wheel rim run out	Radial	—	2 (0.08)
	Axial	—	2 (0.08)
Front brake drum I.D		110 (4.4)	111 (4.44)
Front brake lining thickness		4 (0.16)	1.5 (0.06)
Tie rod length		266.5 (10.66)	—
Rod-end (tie rod) angle		180°	—

TORQUE VALUES

Steering stem nut	7 kgf-m (70 N-m, 50 lbf-ft)
Swing arm nut	4.5 kgf-m (45 N-m, 32 lbf-ft)
Front wheel nut	4.5 kgf-m (45 N-m, 32 lbf-ft)
Front wheel hub nut	7 kgf-m (70 N-m, 50 lbf-ft)
Front shock absorber upper mount bolt	4 kgf-m (40 N-m, 29 lbf-ft)
Front shock absorber lower mount bolt	4 kgf-m (40 N-m, 29 lbf-ft)

SPECIAL TOOLS

Oil seal and bearing install E014

TROUBLESHOOTING

Hard steering (heavy)

- Insufficient tire pressure

Steers to one side or does not track straight

- Uneven front shock absorbers
- Bent front arm
- Bent steering knuckle

Poor brake performance

- Incorrectly adjusted brake
- Worn brake linings
- Contaminated brake lining surface
- Worn brake shoes at cam contacting area
- Worn brake drum
- Poorly connected brake arm

Front wheel wobbling

- Bent rim
- Excessive wheel bearing play
- Bent spoke plate
- Faulty tire
- Improperly tightened axle nut

Soft front shock absorber

- Weak shock springs
- Insufficient damper oil

Front shock absorber noise

- Slider bending
- Loose arm fasteners
- Lack of lubrication

12. FRONT WHEEL/Front BRAKE/Front SUSPENSION/STEERING SYSTEM

FRONT WHEEL

REMOVAL

Place the machine on a level place.
Remove four nuts attaching the wheel panel and front wheel.
Elevate the front wheels by placing a suitable stand under the frame.

* Support the machine securely so there is no danger of it falling over.

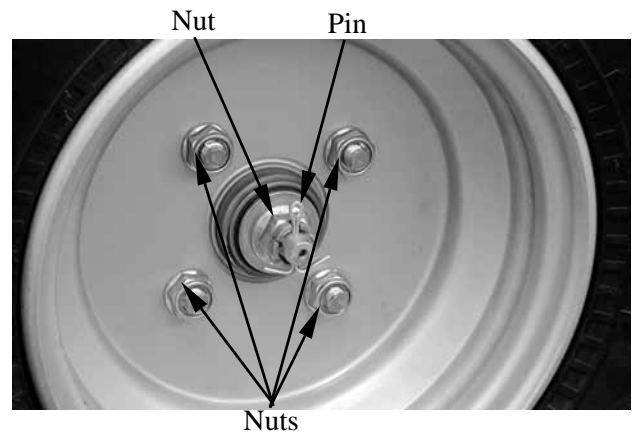

Remove the cotter pin.
Remove nut attaching the wheel hub and washer.
Remove the collar and wheel hub.

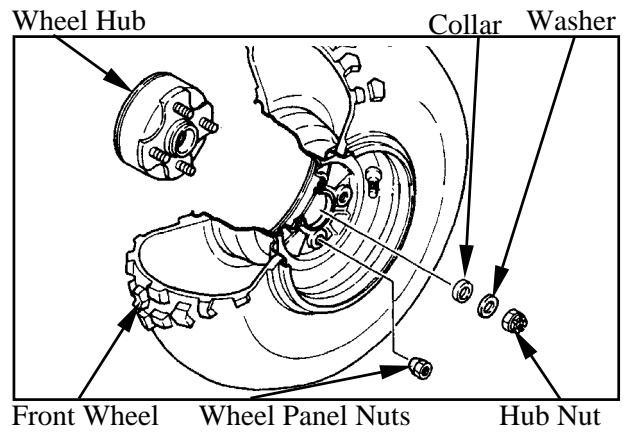

FRONT BRAKE DISASSEMBLY

Loosen the lock nut and tighten the adjuster nut at brake lever. (Refer to the "FRONT BRAKE ADJUSTMENT" section in the CHAPTER 3.).
Disconnect the front brake cable from brake cam lever and remove the brake panel.
Remove the brake shoes.

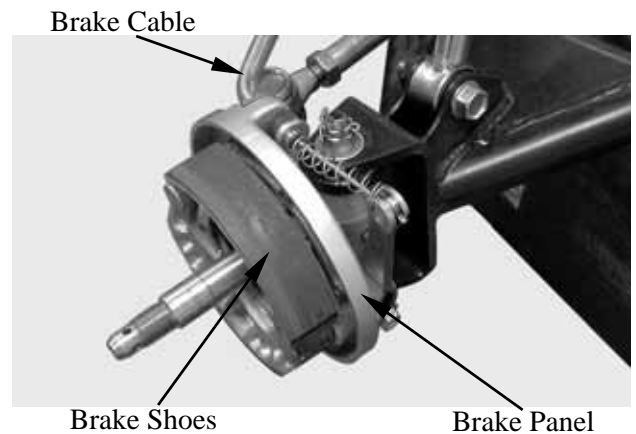

REMOVE

Remove brake shoes and springs.
Remove the bolt attaching camshaft lever and remove camshaft lever.
Remove the wear indicator, camshaft and O-rings

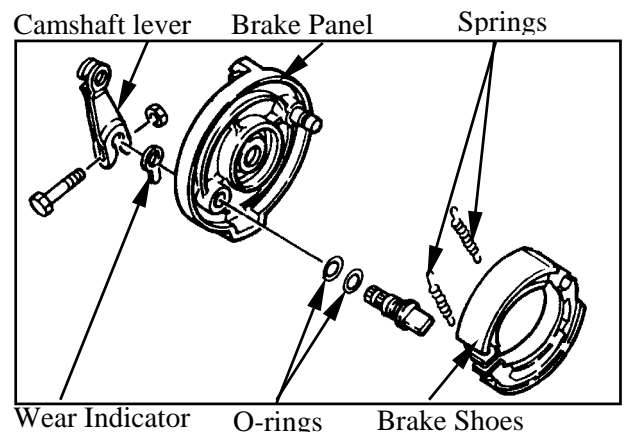

12. FRONT WHEEL/FRONT BRAKE/FRONT SUSPENSION/STEERING SYSTEM

Measure the wheel run out.
Replace wheel or check bearing play if out of specification

Rim run out limits:

Vertical: 2 mm (0.08 in)

Lateral: 2 mm (0.08 in)

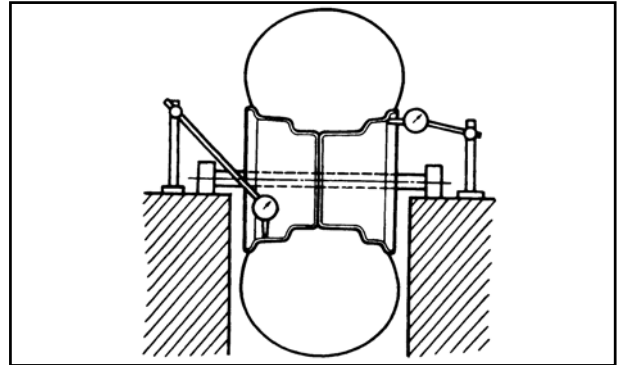

Inspect the front wheel hub.
Replace if cracks or damage.

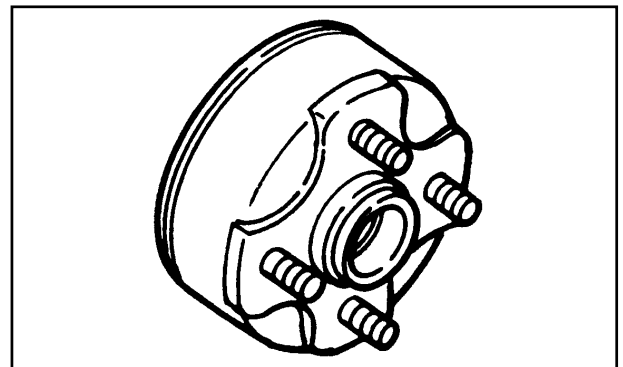

Inspect the front brake drum.
Measure the front brake drum I.D.
Service limits: 111 mm (4.44 in)

* Keep oil or grease off the brake drum.

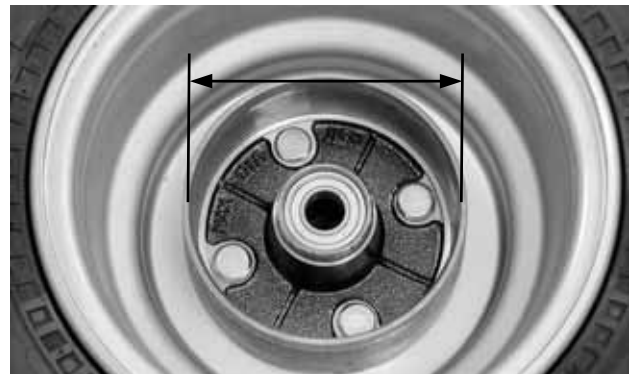

FRONT WHEEL BEARING

Remove the side collar.



12. FRONT WHEEL/FRONT BRAKE/FRONT SUSPENSION/STEERING SYSTEM

Remove the dust seal.

Turn the inner race of each bearing with your finger to see if they turn smoothly and quietly. Also check if the outer race fits tightly in the hub.



BEARING REPLACEMENT

Remove the front wheel bearings and distance collar.



Replace the bearings if the races do not turn smoothly, quietly, or if they fit loosely in the hub.

Apply grease to a new dust seal lip and install the dust seal.

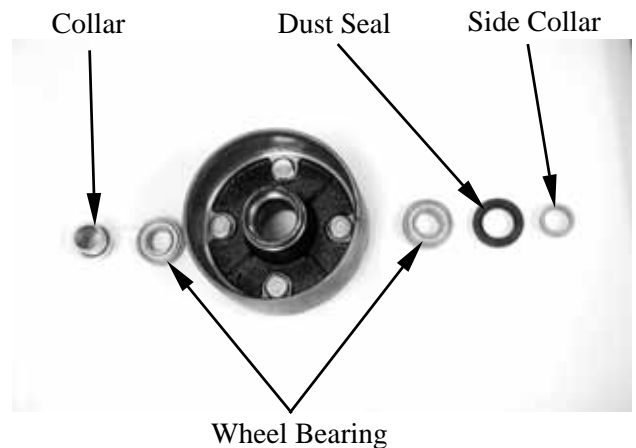

Pack all bearing cavities with grease.
Drive in the left bearing.
Install the distance collar.
Drive in the right bearing.

- *

<ul style="list-style-type: none">• Do not allow the bearings to tilt while driving them in.• Drive in the bearing squarely with the sealed end facing out.
--

Special tool:

Oil seal and bearing install E014



Outer Driver

12. FRONT WHEEL/FRONT BRAKE/FRONT SUSPENSION/STEERING SYSTEM

FRONT BRAKE

FRONT BRAKE LINING INSPECTION

Measure the front brake lining thickness.

Service limit: 2 mm (0.08 in)

- * Keep oil or grease off the brake linings.



REMOVAL

Inspect the shoe springs, O-rings, camshaft lever and wear indicator.

Replace if damage.

Inspect the brake shoe plate.

Replace if cracks or damage.

Inspect the brake shoe pivot pin.

Replace if wear or damage.

Inspect the camshaft hole and camshaft.

Replace if scratches or excessive wear.

INSTALLATION

Reverse the "REMOVAL" procedures.

- *
 - Install the camshaft to the brake shoe plate with the slot of the camshaft placing at bass line of the wear indicator scale.
 - Align the projection with the slot of the camshaft when installing the wear indicator to the camshaft.
 - Align the cut-out of the camshaft lever with the slot of the camshaft when installing the camshaft lever to the camshaft.

Tighten the bolt for camshaft lever.

Torque: 2 kgf-m (20 N-m, 7.5 lbf-ft)

- * Apply the grease onto the O-ring, oil seal lips, pivot pin of brake shoe and camshaft.

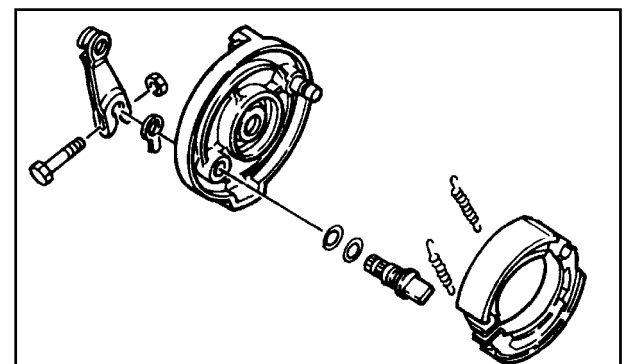
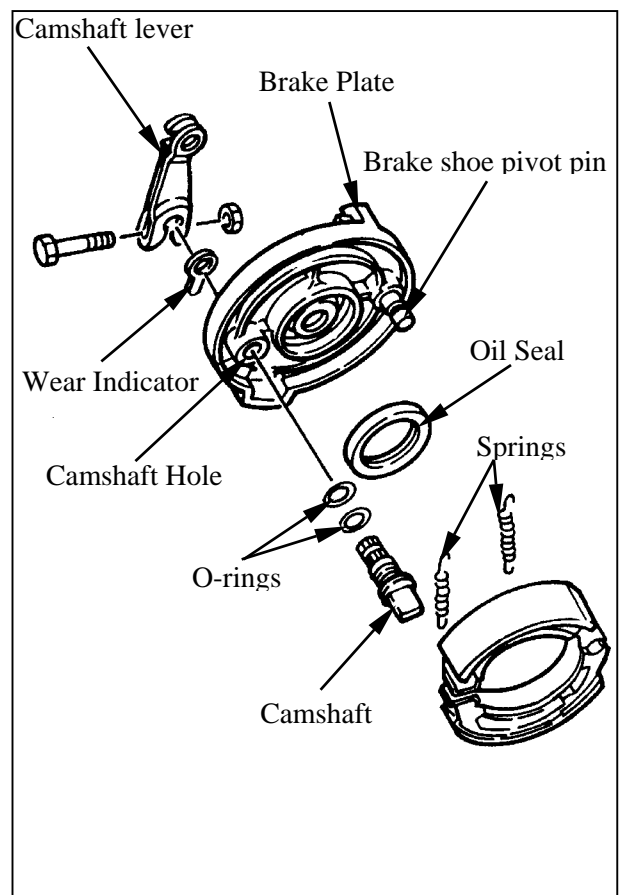

12. FRONT WHEEL/FRONT BRAKE/FRONT SUSPENSION/STEERING SYSTEM

Install the brake shoe plate.

- * Make sure that the boss on the knuckle correctly engages with the locating slot on the brake shoe plate.

Apply the grease onto the bearings and oil seal lips of the wheel hub.
Install wheel hub, plate washer and tight the nut (wheel hub).

Torque: 7 kgf-m (70 N-m, 50 lbf-ft)

Install cotter pins.

- * Always use a new cotter pin.
- * Do not loosen the axle nut after torque tightening. If the axle nut groove is not aligned with the cotter pin hole, align groove with the hole by tightening it on the axle nut.

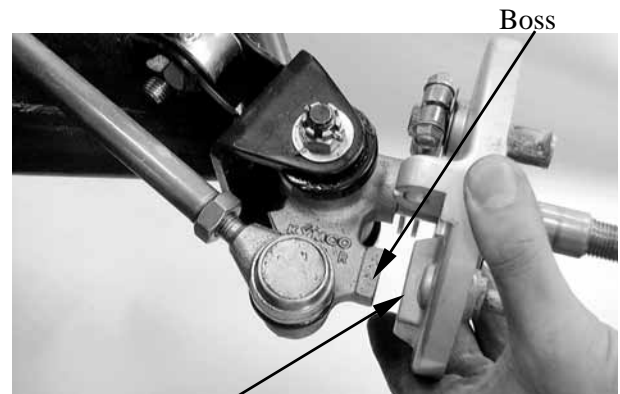

Locating Slot

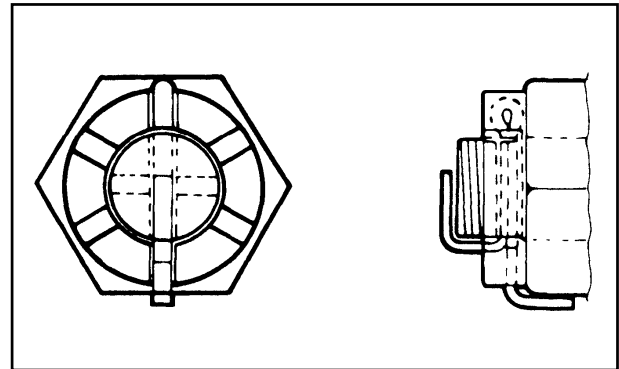

When reinstalling a wheel, tighten the wheel nuts in a crisscross (rather than a circular) pattern.

Torque: 4.5 kgf-m (45 Nm, 32 lbf-ft)

- * **MXU 150:**
 - Tapered wheel nuts are used for front wheels.
 - Install the nuts with its tapered side towards the wheel.



Adjust the front brake cable free play.

Refer to the "FRONT BRAKE ADJUSTMENT" section in the CHAPTER 3.

Brake cable free play: 10~20 mm (0.4~0.8 in) at lever pivot.

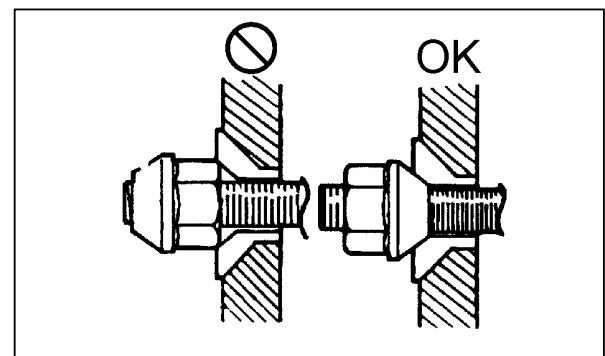

12. FRONT WHEEL/FRONT BRAKE/FRONT SUSPENSION/STEERING SYSTEM

FRONT SUSPENSION

REMOVAL

Elevate the front wheels by placing a suitable stand under the frame.

* Support the machine securely so there is no danger of it falling over.

Remove the front wheel, wheel hub, brake shoe plate.

Remove the upper and lower bolt, then remove the shock absorber.

Remove the cotter pin and nut, then remove tie-rod from steering knuckle.

Remove cotter pin, nut, washer and bolt, then remove the steering knuckle, covers, collar and bush from the front arm.

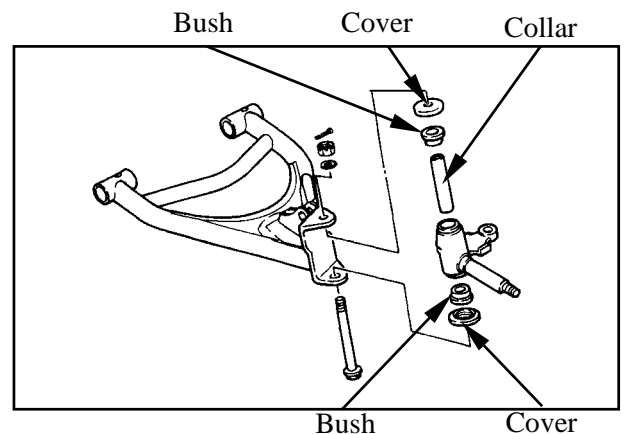
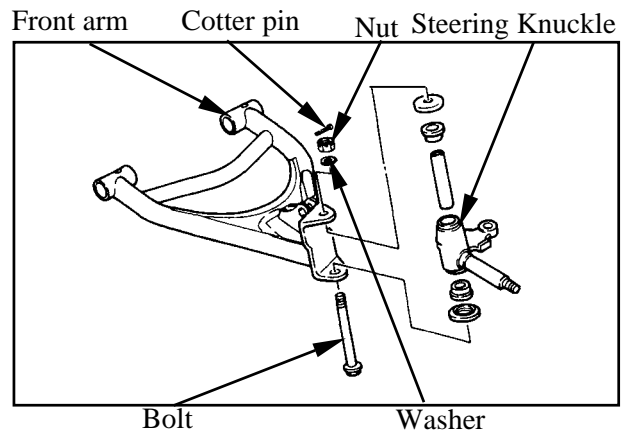
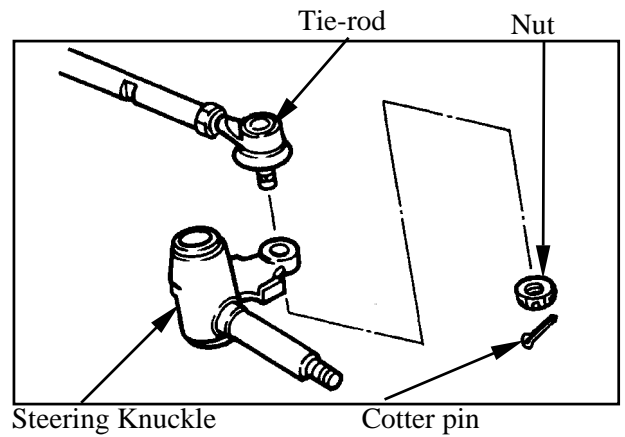
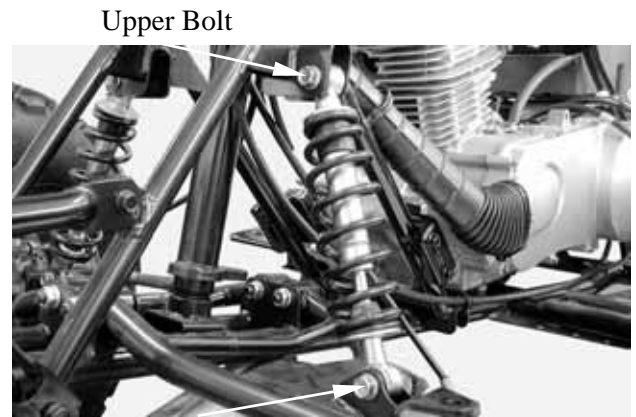

12. FRONT WHEEL/Front BRAKE/Front SUSPENSION/STEERING SYSTEM

INSPECTION

Check the front arm brackets of the frame.

If bent, cracked or damaged, repair or replace the frame.

Check the tightening torque of the front arms securing nuts.

Torque: 4.5 kgf-m (45 N-m, 32 lbf-ft)

Check the front arm side play by moving it from side to side.

If side play noticeable, replace the inner collar, bushings and thrust covers as a set.

Check the front arm vertical movement by moving it up and down.

If vertical movement is tight, binding or rough, replace the inner collar, bushings and thrust covers as a set.

Remove the two nut and two bolt attaching the front arm, then remove the front arm.

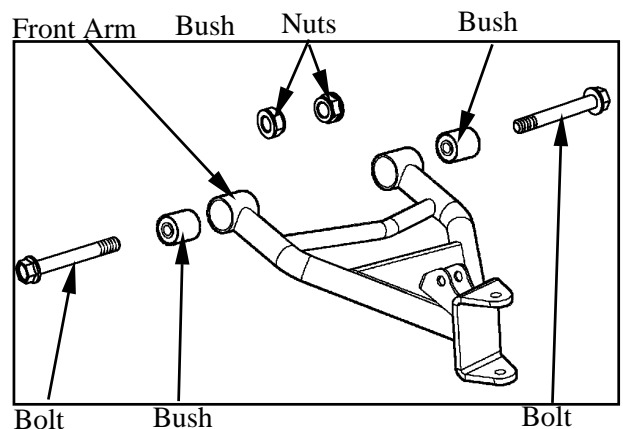
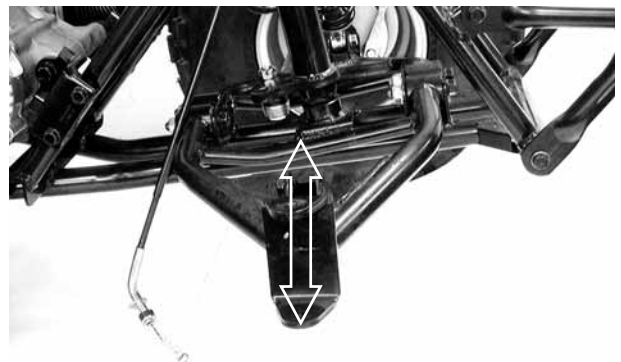
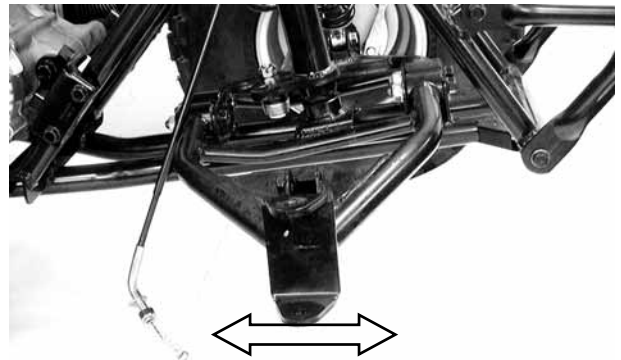

INSPECTION

Inspect the shock absorber rod.

Replace the shock absorber assembly if bends or damage.

Inspect the shock absorber.

Replace the shock absorber assembly if oil leaks.

Inspect the spring of the shock absorber by move the spring up and down.

Replace the shock absorber assembly if fatigue.

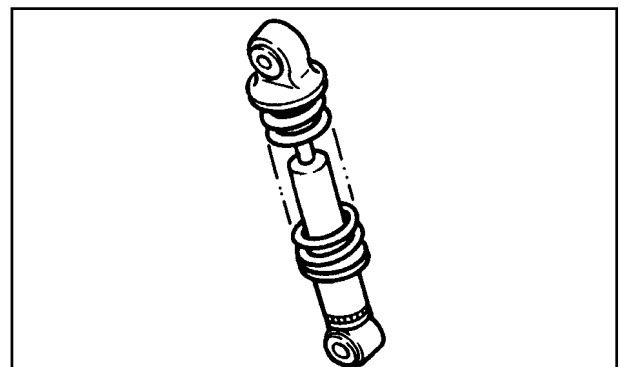

12. FRONT WHEEL/Front BRAKE/Front SUSPENSION/STEERING SYSTEM

Inspect the steering knuckle.
Replace if cracks, pitting or damage.

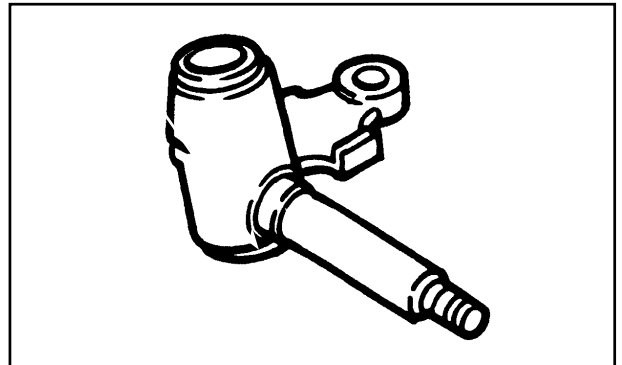

Inspect the front arm.
Replace if cracks, bends or damage.

* Do not attempt to straighten a bent arm, this may dangerously weaken the arm.

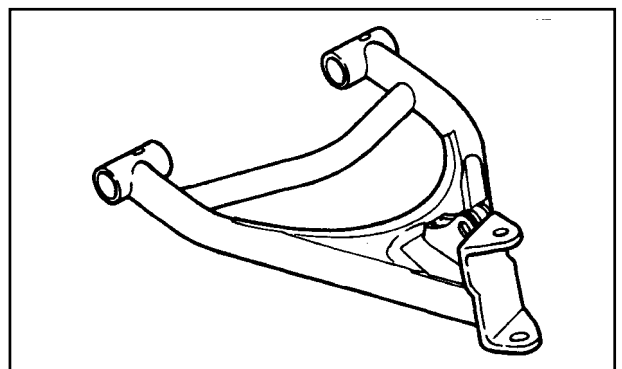

Inspect bushes.
Replace if wear or damage.

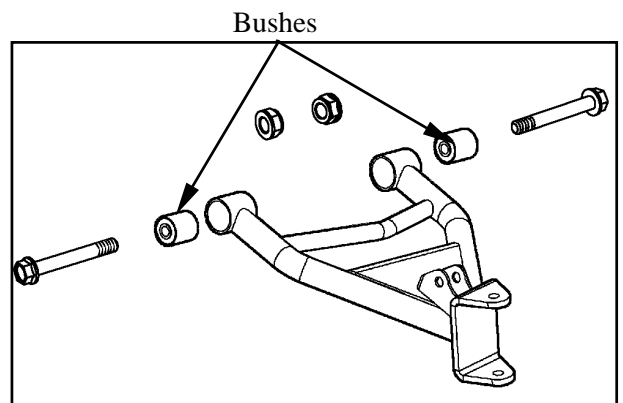

INSTALLATION

Reverse the "REMOVAL" procedures.

* Apply the grease onto the bushes, collars and covers.

Install the front arm nut onto the frame and tighten the nuts.

Torque: 4.5 kgf-m (45 N-m, 32 lbf-ft)

12. FRONT WHEEL/Front BRAKE/Front SUSPENSION/STEERING SYSTEM

Apply the grease onto the bush, collars and covers, then install the steering knuckle onto the front arm and tighten the nut.

Torque: 4.5 kgf-m (45 N-m, 32 lbf-ft)

Install the cotter pin and band ends of cotter pin.

* Always use a new cotter pin.

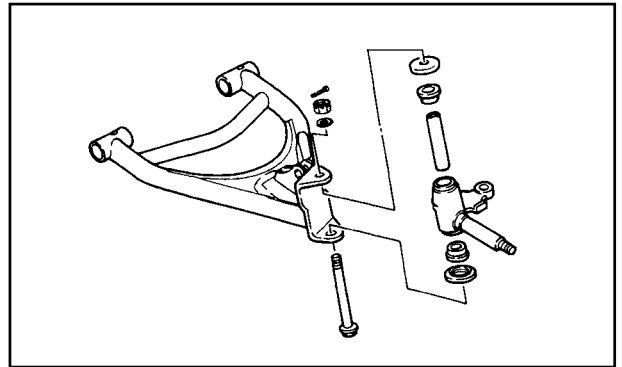

Install the tie-rod onto the steering knuckle and tighten the nut.

Torque: 4.5 kgf-m (45 N-m, 32 lbf-ft)

Install the cotter pin and band ends of cotter pin.

* Always use a new cotter pin.

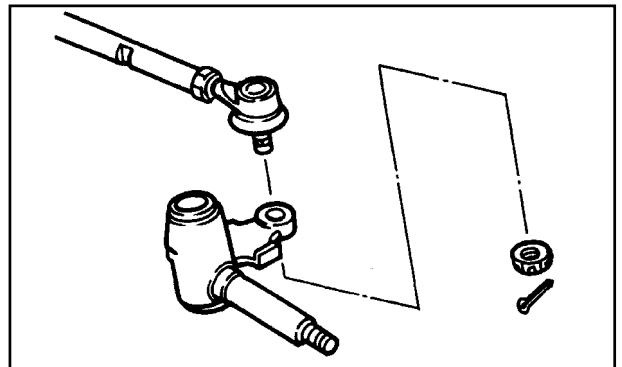

Bleed Valve

Install the shock absorber and tighten the upper and lower bolts.

Torque: 4 kgf-m (40 N-m, 29 lbf-ft)



Install the brake shoe plate, wheel hub and front wheel.

Refer to the "FRONT WHEEL INSTALLATION" section.

12. FRONT WHEEL/Front BRAKE/Front SUSPENSION/STEERING SYSTEM

STEERING SYSTEM

REMOVAL

Remove the following parts:

Seat, Front cover, Center cover and Front fender

Refer to the "FENDERS" section in the CHAPTER 2

(MX'er 150/125: Disconnect the main switch leads.)

(MX'er 150/125: Remove the handlebar cover with main switch.)

Disconnect the front brake cables from the brake lever, rear brake cable from the brake lever and brake switch from the bracket of the brake lever.

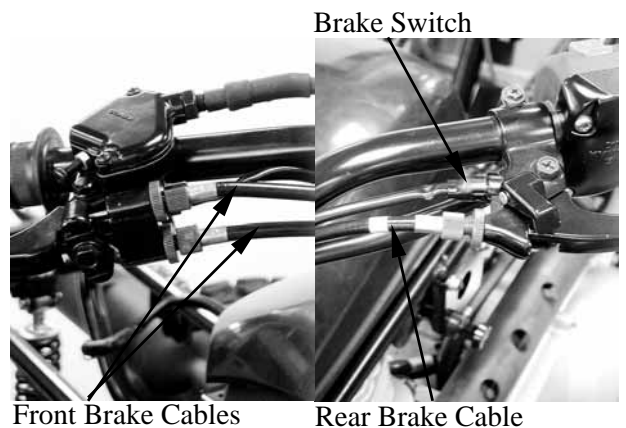
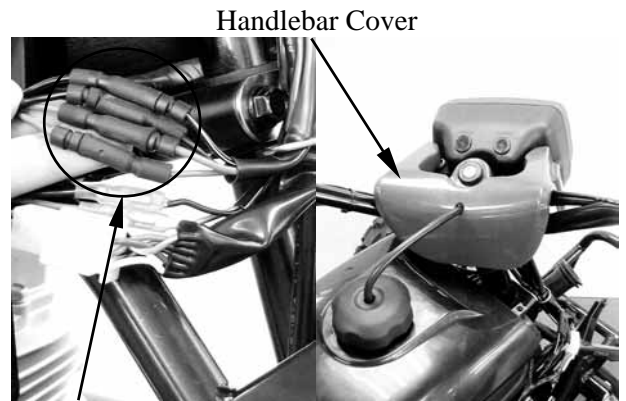

*

Disconnect the brake switch from the bracket of the brake lever while pushing the hook of the brake switch with a driver.

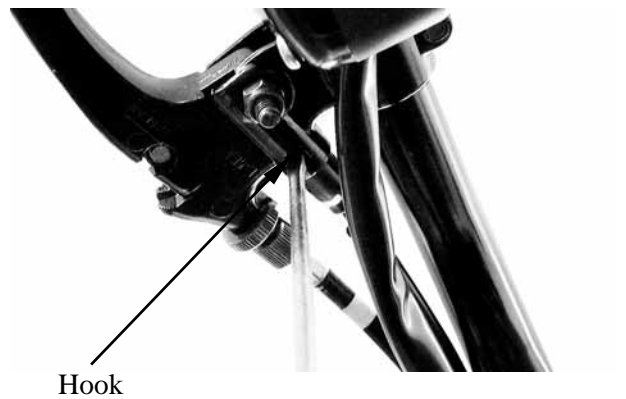

Remove the two screws to remove the cover of the throttle housing.

Disconnect the throttle cable from the lever.

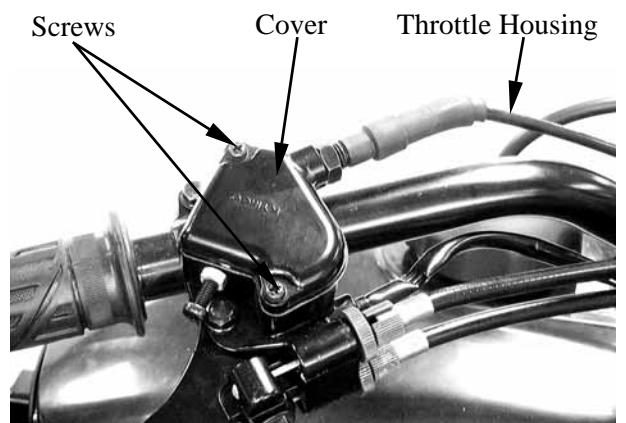

12. FRONT WHEEL/FRONT BRAKE/FRONT SUSPENSION/STEERING SYSTEM

Remove the two screws and remove the handlebar switch.

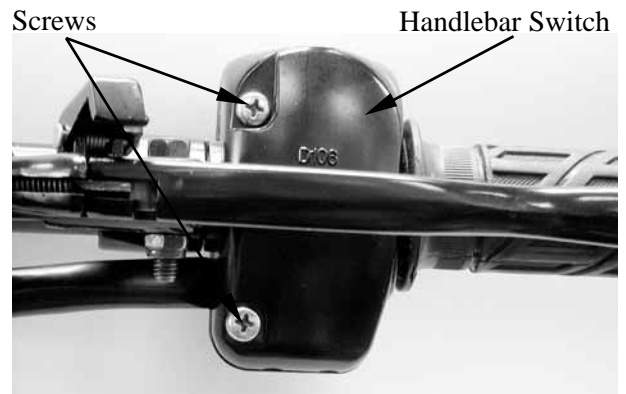

(MX'er 150/125: Remove the two bolts and remove headlight unit.)

Remove the four handlebar holder bolts and remove the handlebar.

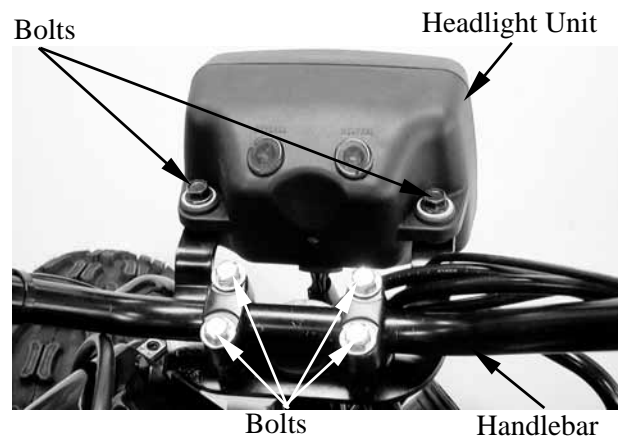

Remove the cotter pins and nuts attaching the tie-rods, then remove tie-rods.

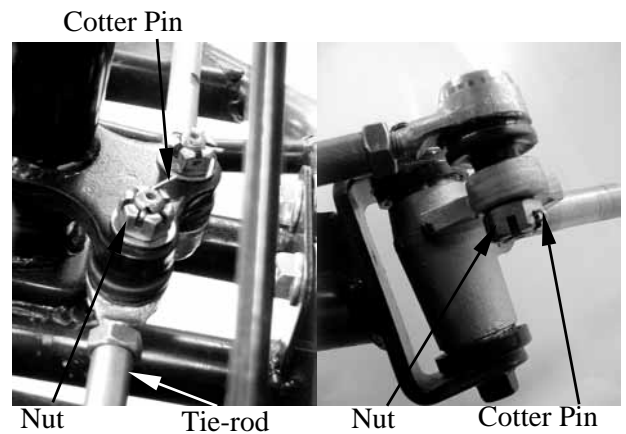

Remove the cotter pin and nut attaching the steering column, then remove steering column and collar.

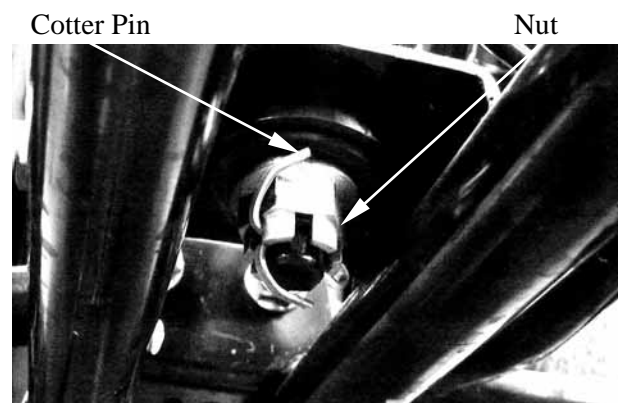

12. FRONT WHEEL/Front BRAKE/Front SUSPENSION/STEERING SYSTEM

Remove the two bolts to remove the cable holder, steering bracket, collars and steering column.

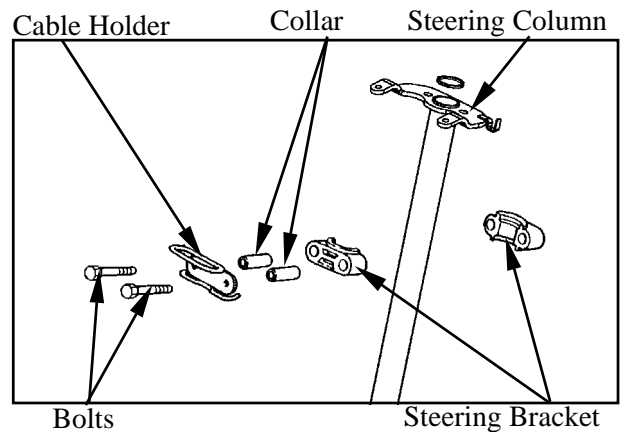

INSPECTION

Inspect the handlebar.
Replace if cracks, bends or damage.

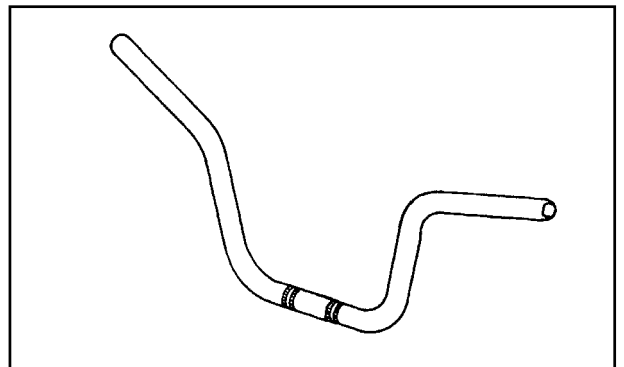

Inspect the steering column.
Replace if bends or damage.

* Do not attempt to straighten a bent shaft, this may dangerously weaken the shaft.

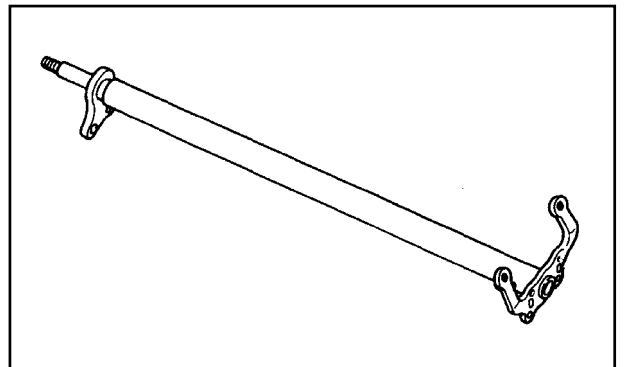

Inspect the steering brackets and oil seal.
Replace if wear or damage.

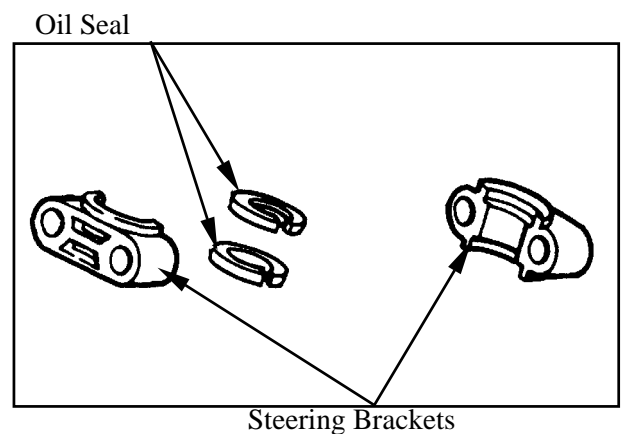

12. FRONT WHEEL/FRONT BRAKE/FRONT SUSPENSION/STEERING SYSTEM

Inspect the tie-rod.
Replace if bend or damage.

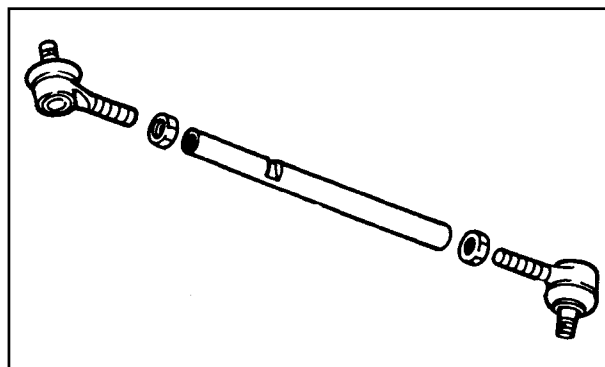

Check the tie-rod end movement.
Replace if the tie-rod end exists free play or turns roughly.
Check the tapered surface of the tie-rod end.
Replace if pitting, wear or damage.

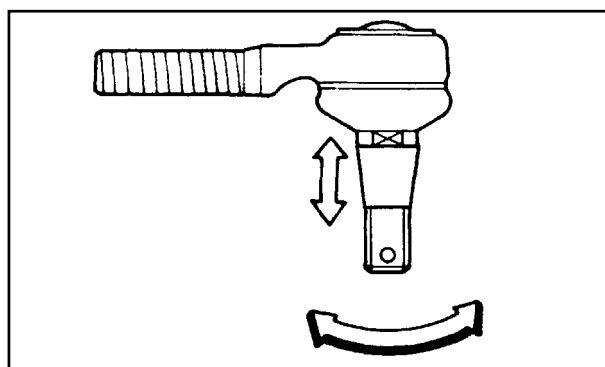

Adjust the tie-rod length.
Adjustment steps:
(The following procedures are done on both tie-rods, right and left.)
Loosen the lock nuts.
Adjust the tie-rod length by tuning both tie-rod ends.

Tie rod length: 266.5 mm (10.66 in)

Set the rod-end (steering column side) in an angle where the indentation surface of the tie-rod is parallel to the rod-end shaft, and then tighten the lock nut.

Torque: 3 kgf-m (30 N-m, 22 lbf-ft)

Set the other rod-end (knuckle arm side) in an angle as shown (right-hand tie-rod and left-hand tie-rod), and then tighten the lock nut.

Rod-end (tie rod) angle: 180°

Torque: 3 kgf-m (30 N-m, 22 lbf-ft)

* After making adjustment on both tie rods be sure to mark them R and L for identification.

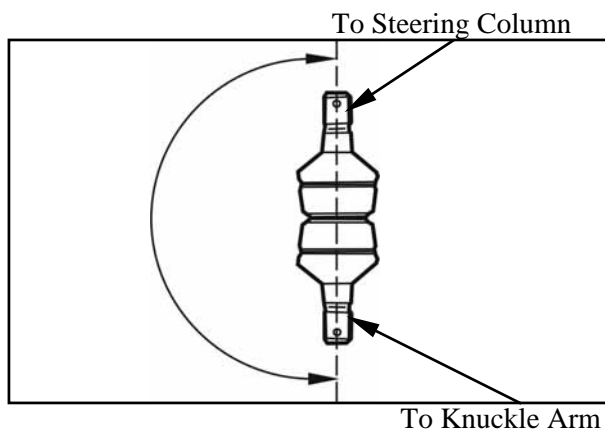
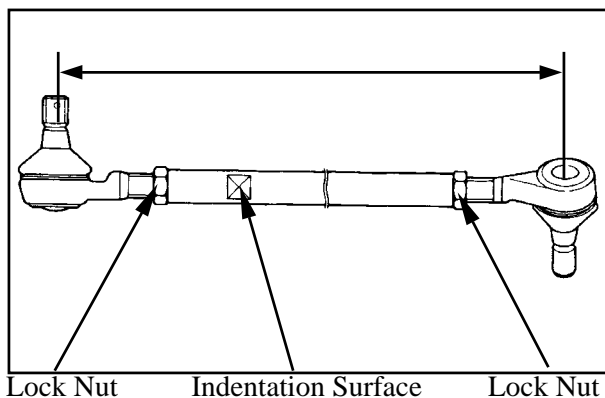

12. FRONT WHEEL/Front BRAKE/Front SUSPENSION/STEERING SYSTEM

* The threads on both rod-end must be of the same length.

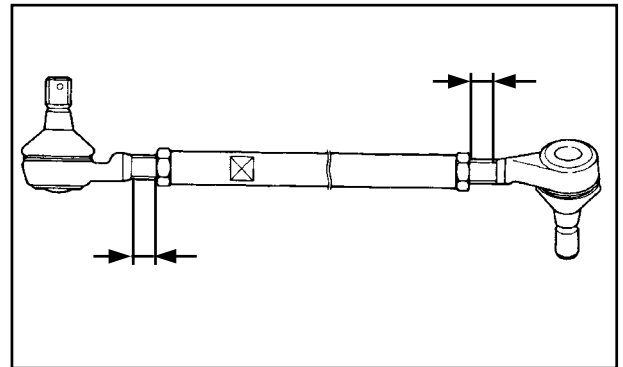

Inspect the collar, duty seal, snap ring and bearing.
Replace if wear or damage.

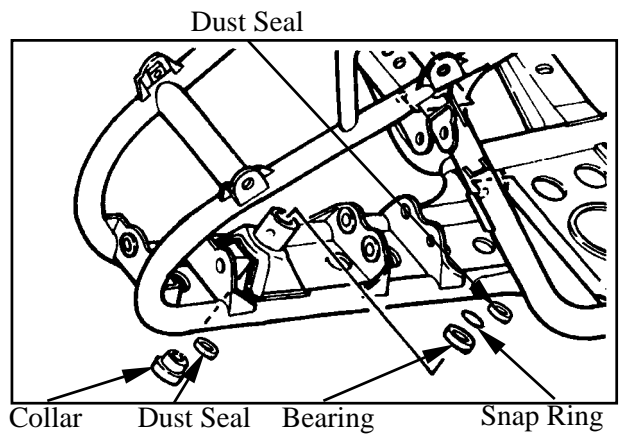

INSTALLATION

Reverse the "REMOVAL" procedures.

* Apply the grease onto the collar, duty seal, and bearing.

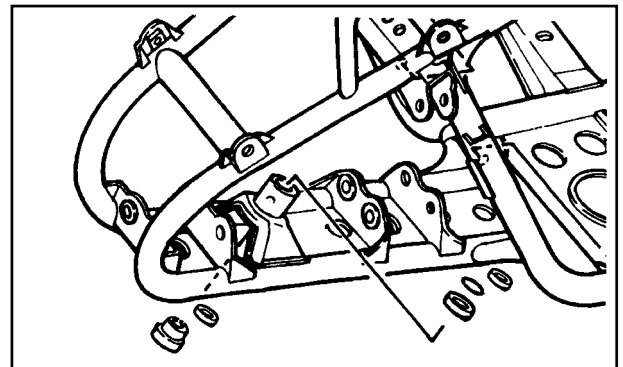

Assembly the steering column and tighten the two bolts.

Torque: 2 kgf-m (20 N-m, 15 lbf-ft)

Band the lock washer tabs.

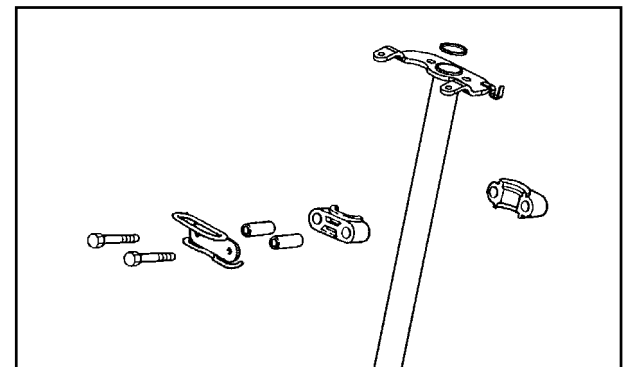

12. FRONT WHEEL/Front BRAKE/Front SUSPENSION/STEERING SYSTEM

Install the steering column and collar, then tighten the nut.

Torque: 7 kgf-m (70 N-m, 50 lbf-ft)

Install the cotter pin and band ends of cotter pin.

* Always use a new cotter pin.

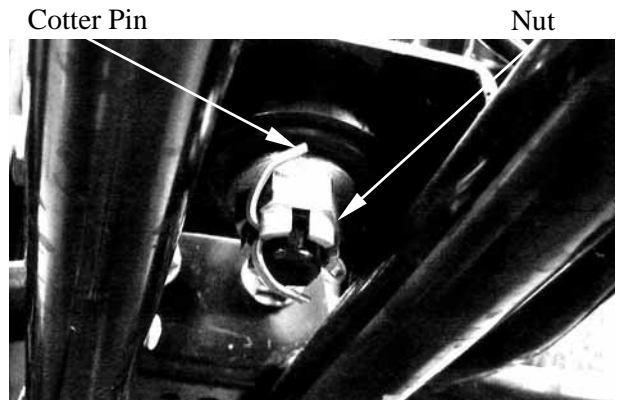

Install the tie rods and tighten the nut.

Torque: 4.5 kgf-m (45 N-m, 32 lbf-ft)

Install the cotter pin and band ends of cotter pin.

* Always use a new cotter pin.

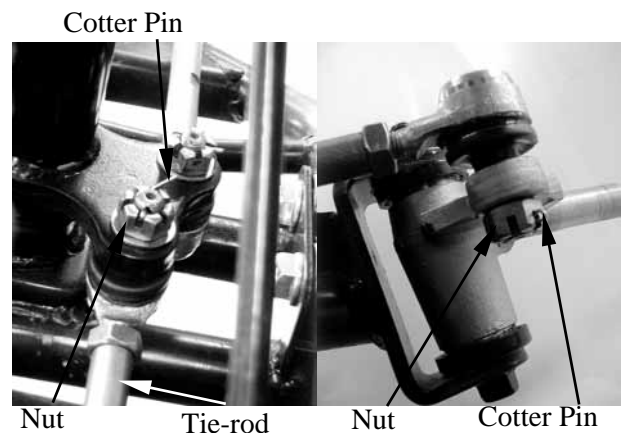

* Be sure that the rod-end on the indentation surface side is connected to the steering column.

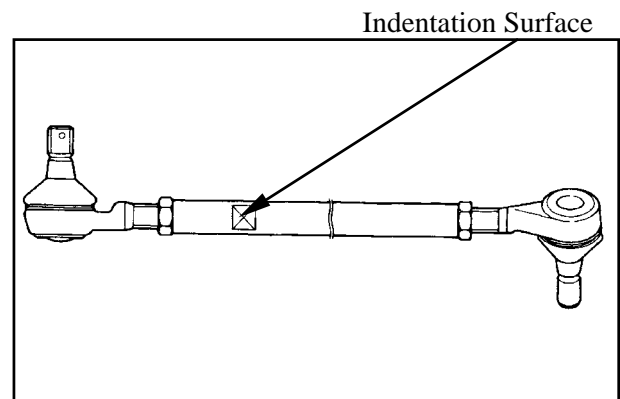

Install handlebar and handlebar holder, then tighten the four bolts.

Torque: 2 kgf-m (20 N-m, 15 lbf-ft)

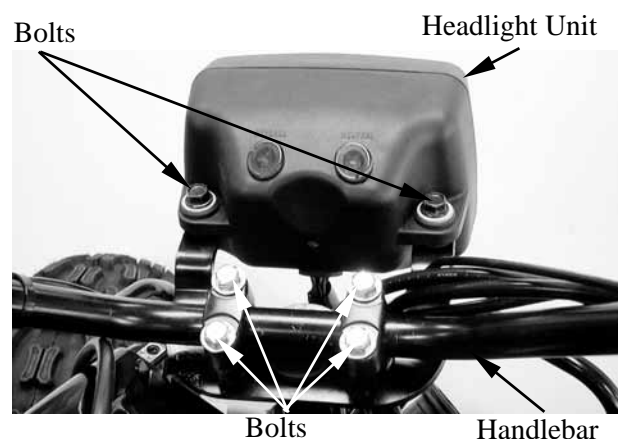

12. FRONT WHEEL/FRONT BRAKE/FRONT SUSPENSION/STEERING SYSTEM

- * **•** Be sure the upper handlebar holder mark face to front.
- First tighten the bolts on the front side of the handlebar holder, and then tighten the bolts on the rear side.

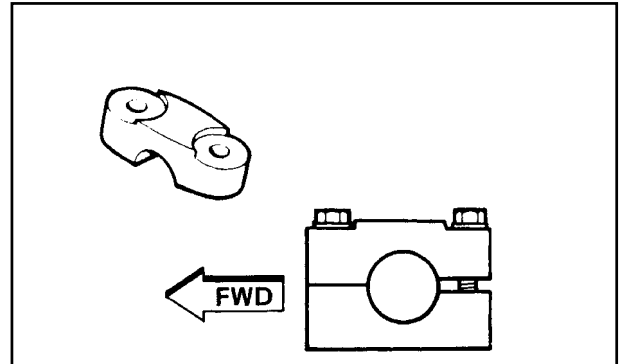

Apply the grease onto the end of the throttle cable and end of the brake cable.

Refer to the “TOE-IN ADJUSTMENT” section in the CHAPTER 3 to adjust toe-in.

Refer to the “FRONT BRAKE ADJUSTMENT” section in the CHAPTER 3 to adjust front brake.

Refer to the “REAR BRAKE ADJUSTMENT” section in the CHAPTER 3 to adjust rear brake.

**REAR WHEEL/SWING ARM/
HYDRAULIC BRAKE**

SERVICE INFORMATION-----	13- 2
TROUBLESHOOTING-----	13- 4
REAR WHEEL-----	13- 5
SWING ARM -----	13- 14
HYDRAULIC BRAKE -----	13- 18

13. REAR WHEEL/SWING ARM/ HYDRAULIC BRAKE

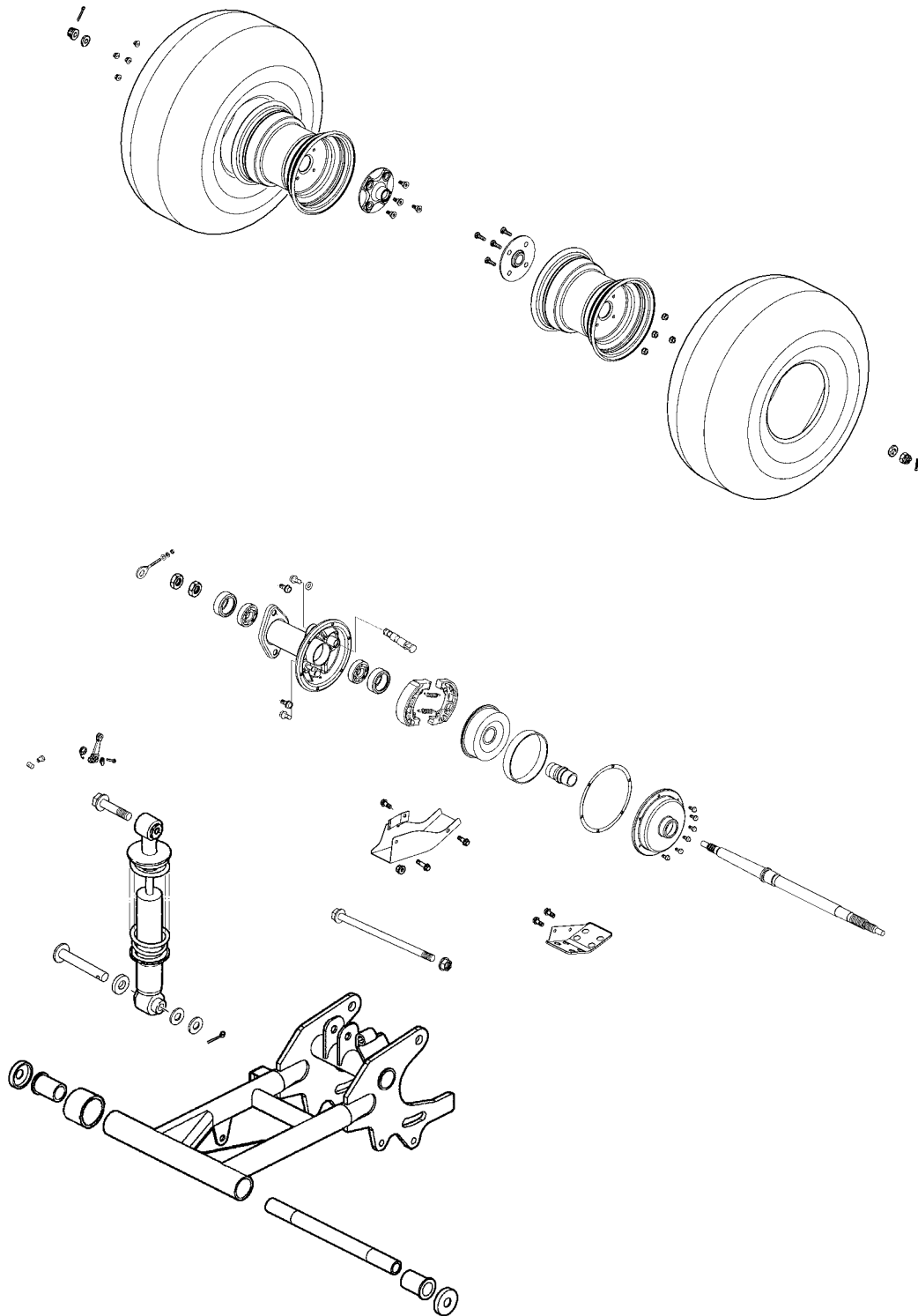

SERVICE INFORMATION

GENERAL INSTRUCTIONS

- During servicing, keep oil or grease off the brake drum and brake linings.
- Drain the brake fluid from the hydraulic brake system before disassembly.
- Contaminated brake disk or brake pads reduce stopping power. Clean the contaminated brake disk with high-performance brake degreaser and replace the brake pads.
- Do not use brake fluid for cleaning.
- Bleed air from the brake system if the brake system is removed or the brake is soft.
- Do not allow any foreign matters entering the brake reservoir when filling the brake reservoir with brake fluid.
- Brake fluid will damage painted, coated surfaces and plastic parts. When working with brake fluid, use shop towels to cover and protect painted, rubber and plastic parts. Wipe off any splash of brake fluid with a clean towel. Do not wipe the motorcycle with a towel contaminated by brake fluid.
- Make sure to use recommended brake fluid. Use of other unspecified brake fluids may cause brake failure.
- Inspect the brake operation before riding.

SPECIFICATIONS

mm (in)

Item		Standard	Service Limit
Rear wheel	Rim run out	Radial	—
		Axial	2 (0.08)
	Rear brake drum I.D	130 (5.2)	131 (5.24)
Rear brake lining thickness		4.5 (0.18)	2 (0.08)
Brake disk thickness		3.7 (0.148)	3 (0.12)
Brake disk runout		0.15 (0.006)	0.3 (0.012)
Brake master cylinder I.D.		12.7 ~ 12.743 (0.508 ~ 0.50972)	12.75 (0.51)
Brake master cylinder piston O.D.		12.657 ~ 12.684 (0.50628 ~ 0.50736)	12.64 (0.5056)
Brake caliper piston I.D.		33.95 ~ 33.99 (1.358 ~ 1.3596)	34.05 (1.362)
Brake caliper cylinder O.D.		33.88 ~ 33.92 (1.3552 ~ 1.3568)	33.85 (1.654)

13. REAR WHEEL/SWING ARM/ HYDRAULIC BRAKE

TORQUE VALUES

Rear wheel nut	4.5 kgf-m (45 N-m, 32 lbf-ft)
Rear shock absorber upper mount bolt	4 kgf-m (40 N-m, 29 lbf-ft)
Rear swing arm axle	7 kgf-m (70 N-m, 50 lbf-ft)
Rear wheel hub nut	7 kgf-m (70 N-m, 50 lbf-ft)
Rear wheel shaft nut	12 kgf-m (120 N-m, 86 lbf-ft)
Brake arm bolt	2 kgf-m (20 N-m, 15 lbf-ft)
Caliper holder bolt	3.2 kgf-m (32 N-m, 24 lbf-ft)
Brake fluid tube bolt	3.5 kgf-m (35 N-m, 25 lbf-ft)
Caliper bleed valve	0.6 kgf-m (6 N-m, 4.3 lbf-ft)
Master cylinder bolt	1.2 kgf-m (12 N-m, 8.6 lbf-ft)

SPECIAL TOOLS

Nut wrench F010

TROUBLESHOOTING

Rear wheel wobbling

- Bent rim
- Faulty tire
- Axle not tightened properly

Soft rear shock absorber

- Weak shock absorber spring
- Faulty damper

Loose brake lever

- Air in hydraulic brake system
- Brake fluid level too low
- Hydraulic brake system leakage

Hard braking

- Seized hydraulic brake system
- Seized piston

Brake noise

- Contaminated brake pad surface
- Excessive brake disk run out
- Incorrectly installed caliper
- Brake disk or wheel not aligned

Poor brake performance (Disk Brake)

- Air in brake system
- Deteriorated brake fluid
- Contaminated brake pads and brake disk
- Worn brake pads
- Worn brake master cylinder piston oil seal
- Clogged brake fluid line
- Deformed brake disk
- Unevenly worn brake caliper

Poor brake performance

- Brake not adjusted properly
- Worn brake linings
- Worn brake shoes at cam contacting area
- Worn brake cam
- Worn brake drum

Tight brake lever

- Seized piston
- Clogged hydraulic brake system
- Smooth or worn brake pad

Poor brake performance

Contaminated brake pad surface

13. REAR WHEEL/SWING ARM/ HYDRAULIC BRAKE

REAR WHEEL

REMOVAL

Place the machine on a level place.
Use the nut wrench to loosen two nuts
(inner and outer) of the rear axle.

Special tool:

Nut wrench F010

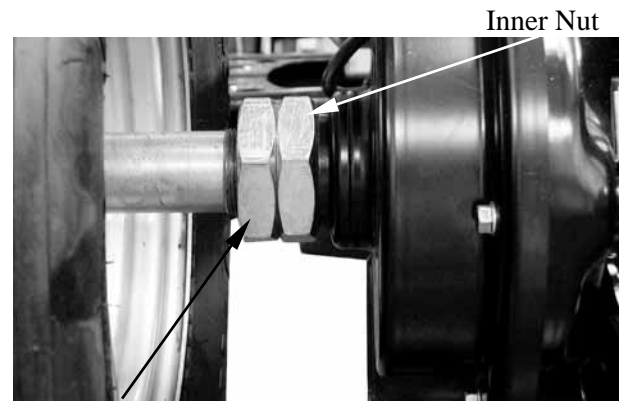

Outer Nut

Inner Nut

Remove the cotter pin.

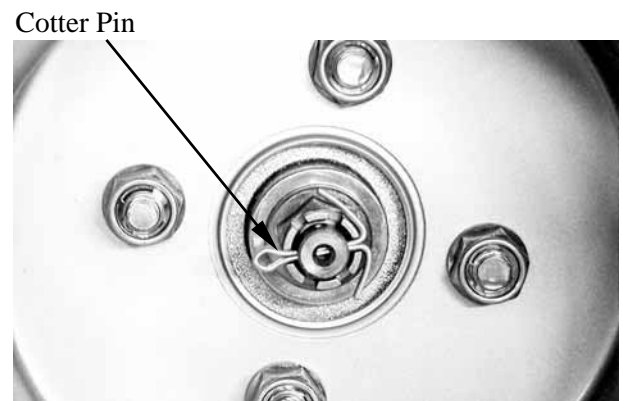

Cotter Pin

Remove four nuts attaching the wheel panel
of the both rear wheels.
Loosen nut attaching the wheel hub of the
both rear wheels.

★

Elevate the rear wheels by placing a
suitable stand under the rear of frame.
Support the machine securely so there is
no danger of it falling over.

Nut Attaching The Wheel Hub

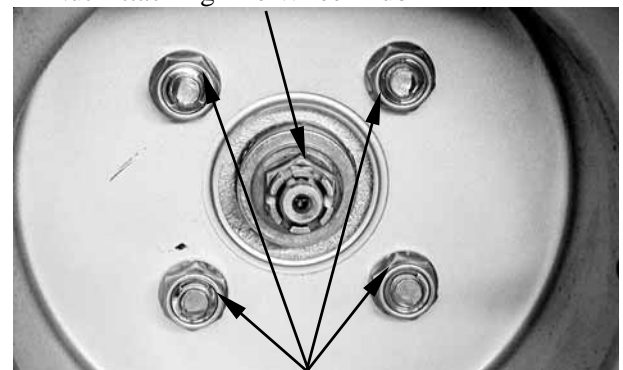

Nuts Attaching The Wheel Panel

Remove

Remove four nuts attaching the wheel panel
and rear wheel.
Remove nut attaching the wheel hub and
washer.
Remove the wheel hub.

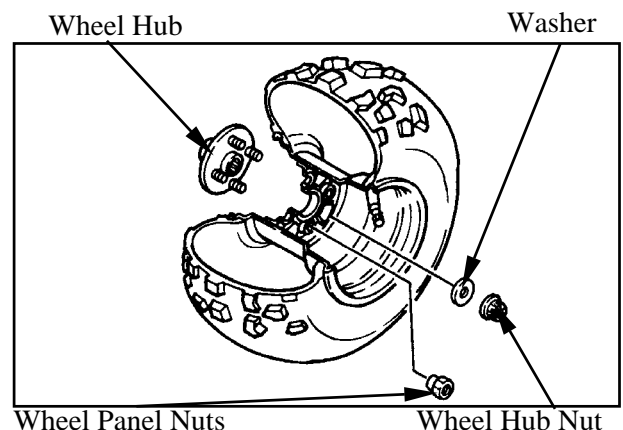

Wheel Hub

Washer

Wheel Panel Nuts

Wheel Hub Nut

13. REAR WHEEL/SWING ARM/ HYDRAULIC BRAKE

Inspection

Measure the wheel runout.

Service Limit:

Vertical: 2 mm (0.08 in)

Lateral: 2 mm (0.08 in)

Replace wheel or check bearing play if out of specification.

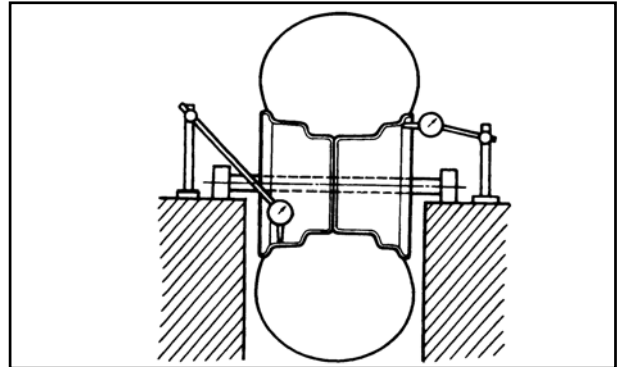

Remove two nuts of the rear axle (outer and inner).

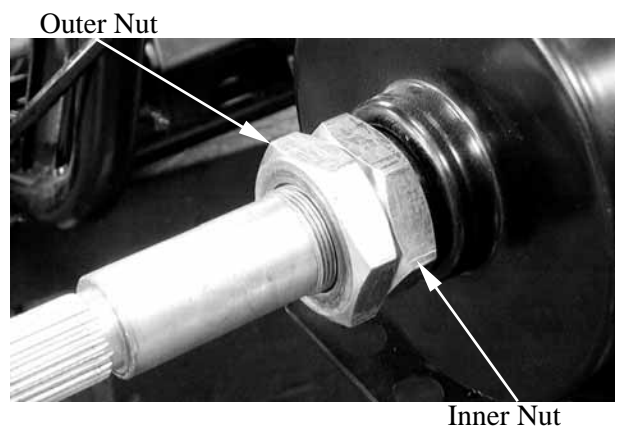

Remove five bolts attaching left and right lower guard.

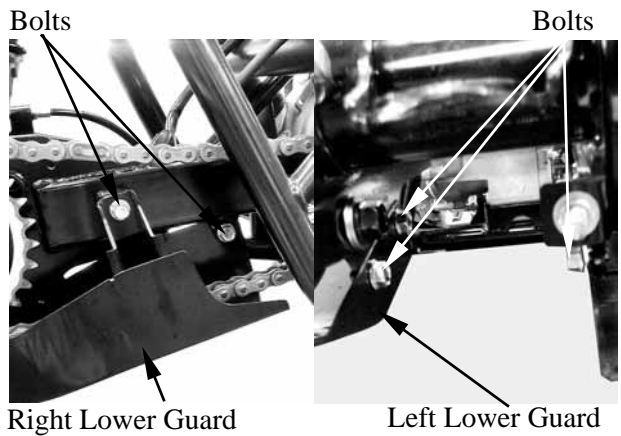

Loosen the lock nut for the adjuster of the drive chain slack.

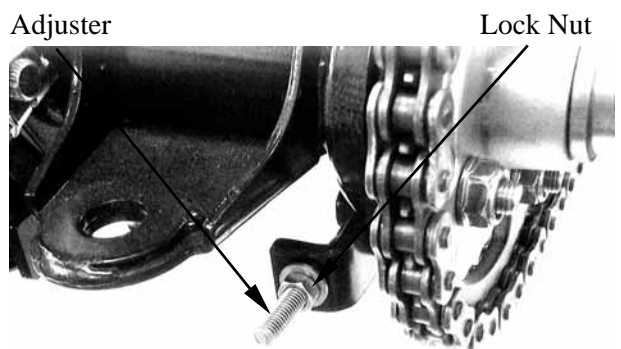

13. REAR WHEEL/SWING ARM/ HYDRAULIC BRAKE

Loosen four bolts attaching rear axle hub.

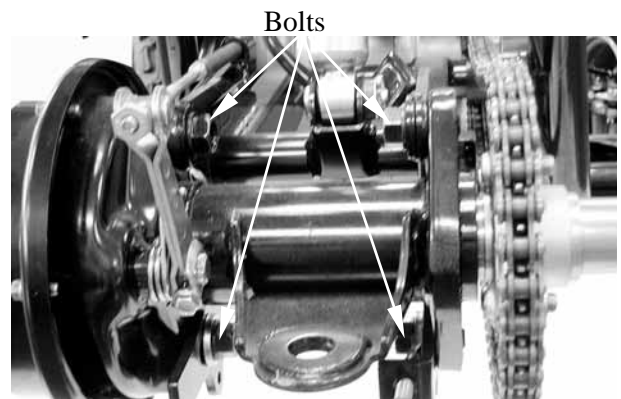

Remove the drive chain from driven sprocket.

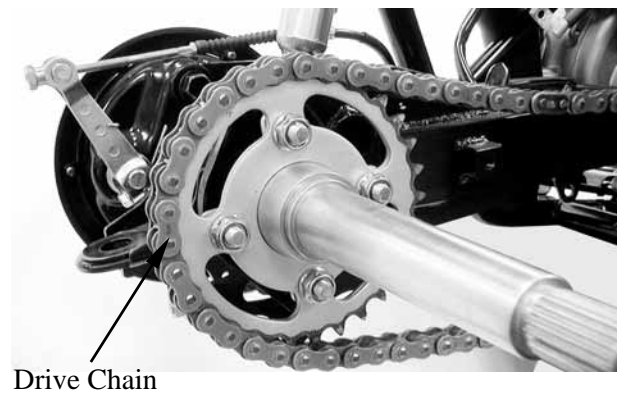

Remove six bolts attaching brake drum cover.

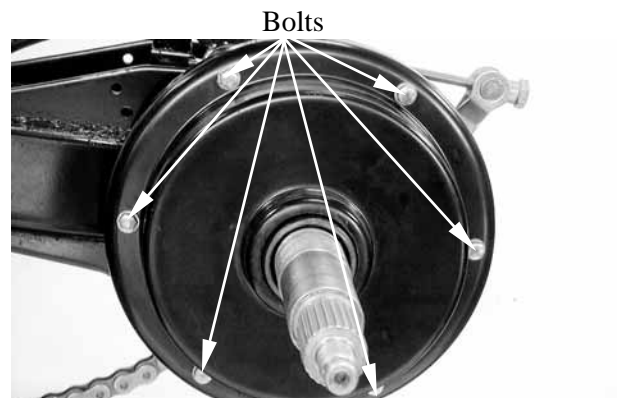

Remove brake drum cover and rubber spacer.

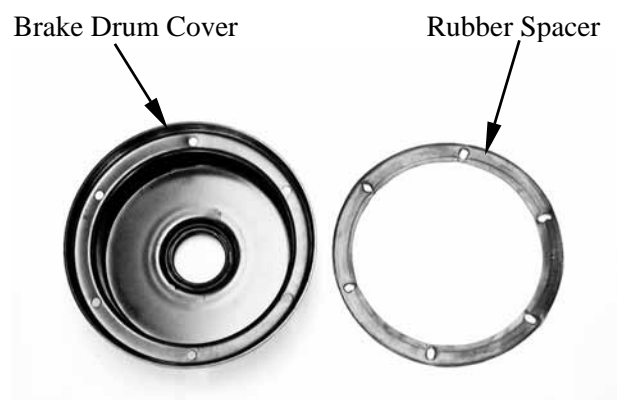

13. REAR WHEEL/SWING ARM/ HYDRAULIC BRAKE

Inspection

Inspect the inner surface of the brake drum is scratches, polish brake drum lightly and evenly with emery cloth.

Measure the inside diameter of the brake drum.

Service limit: 131 mm (5.24 in)

Replace if it is out of specification.



Disconnect the rear brake cable from the camshaft lever.

Brake Cable



Remove the brake shoes.

INSPECTION

Measure lining thickness of the brake shoes.

Service limit: 2 mm (0.08 in)

Replace if it is out of specification.

Brake Shoes



Remove the rear axle from left side.

* Tap the axle and with a rubber hammer, this will avoid damage the axle thread.

Rear Axle



13. REAR WHEEL/SWING ARM/ HYDRAULIC BRAKE

Remove four bolts and the rear axle hub.

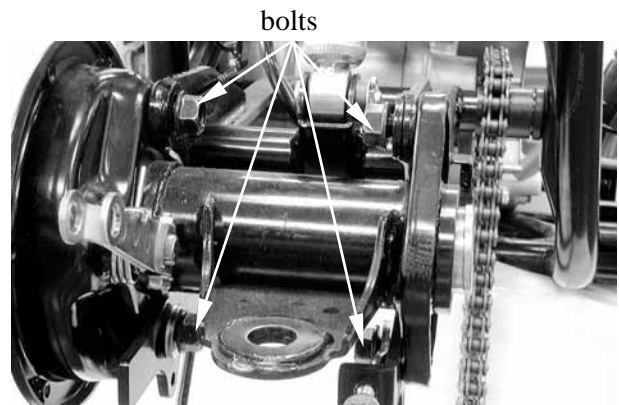

INSPECTION

Replace if the wheel hub is cracked or damage.

Replace if splines of the wheel hub is wear or damage.

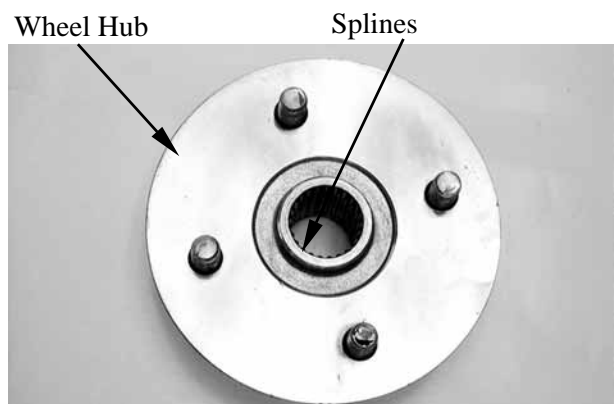

Replace if the rear axle is scratched (excessively) or damage.

Replace if splines and threads of the rear axle is wear or damage.

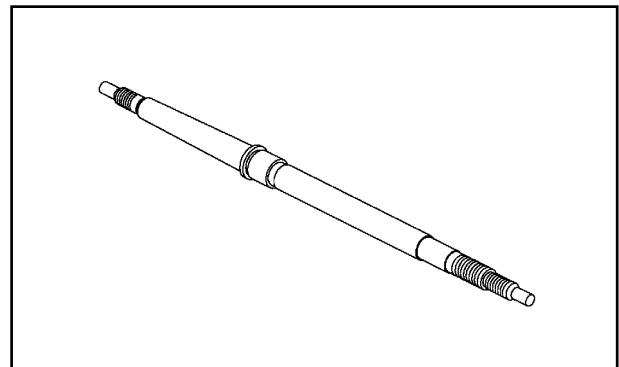

Measure the rear axle run out.

Service limit: less than 1.5 mm (0.06 in)

Replace if it is out of specification.

* Do not attempt to straighten a bent axle.

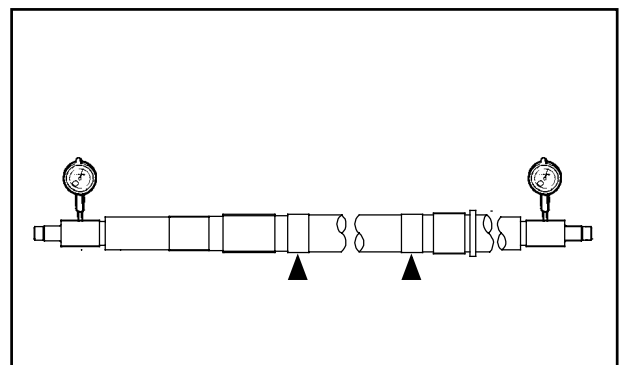

13. REAR WHEEL/SWING ARM/ HYDRAULIC BRAKE

DRIVE CHAIN INSPECTION

Remove rear wheels, rear hub (with rear axle) and swing arm.

Refer to the “REAR WHEEL — REMOVAL” and “SWING ARM REMOVAL” section.

Remove right foot board.

Remove the drive sprocket.

Remove the drive chain.

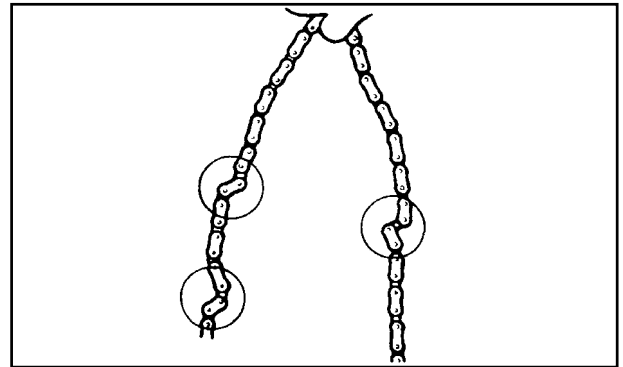

Inspect the drive chain stiffness.

Clean and lubricate or replace if stiff.

Inspect the drive sprocket and the driven sprocket.

Replace sprocket if more than 1/4 teeth wear or bent teeth.

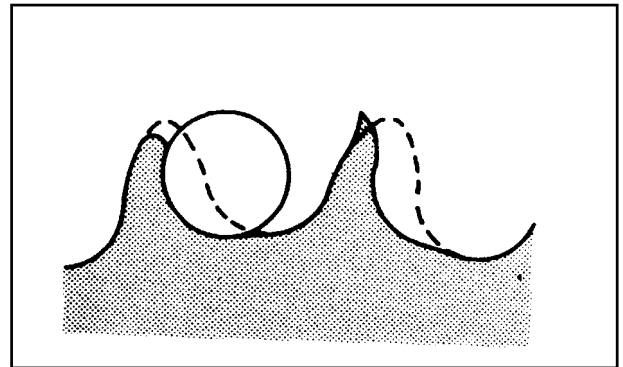

CLEAN

Place it in kerosene, and brush off as much dirt as possible. Then remove the chain from the kerosene and dry the chain.

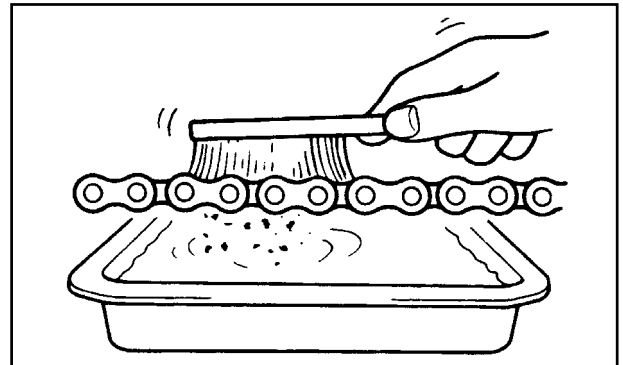

*

This machine has a drive chain with small rubber O-rings between the chain plates. Steam cleaning, high-pressure washes, and certain solvent can damage these O-rings. Use only kerosene to clean the drive chain.

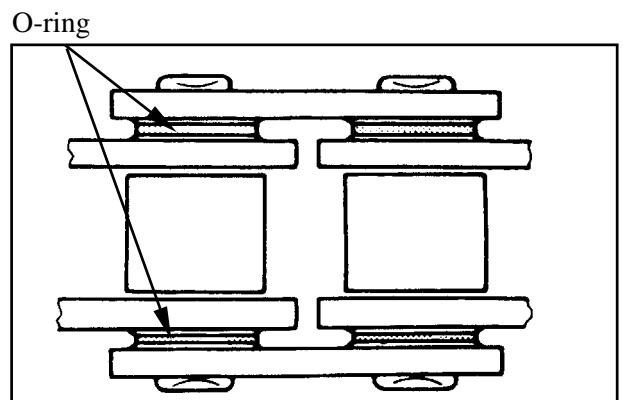

13. REAR WHEEL/SWING ARM/ HYDRAULIC BRAKE

Inspect rear axle hub.

Replace if bearings allow play in the axle hub or the bearing turns roughly.

Replace if oil seals is wear or damage.

Replace if rear axle hub is cracks, bend or damage.

Bearing and oil seal replacement steps:

Clean the outside of the rear axle.

Remove the oil seal by a flat-head screw driver.

*

Place a wood block against the outer edge to protect this edge.

Remove the bearing by a general bearing puller.

Install the new bearings and oils seal by reversing the previous steps.

*

Do not strike the center race or balls of the bearing.
Contact should be made only with the outer race.

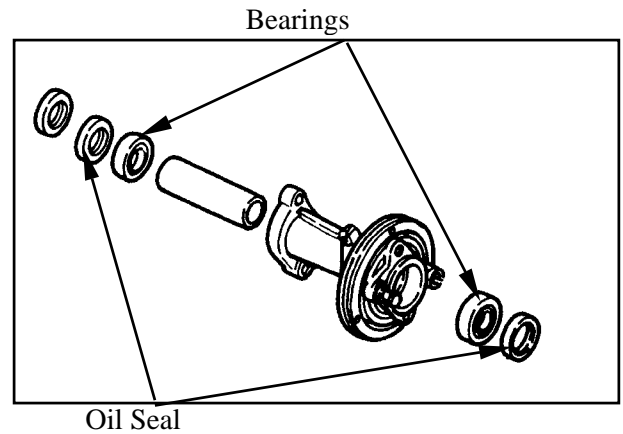

INSTALLATION

Reverse the "REMOVAL" procedures.

*

Apply grease onto the oil seal lips, bearings and bushes.

Install the rear axle hub.

*

At this time, the rear axle hub should not be tightened completely.
Final tightening is done after the chain slack adjustment.

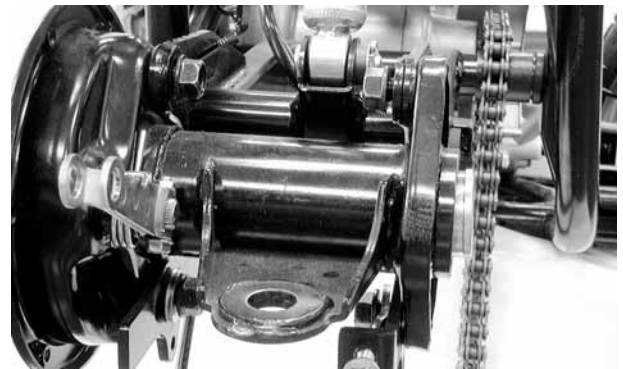

Install the rear axle.

*

Tap the axle and with a rubber hammer, this will avoid damage the axle thread.



13. REAR WHEEL/SWING ARM/ HYDRAULIC BRAKE

Install the brake drum.
Install the rubber spacer and brake drum cover.

Torque: 1 kgf-m (10 N-m, 7.2 lbf-ft)

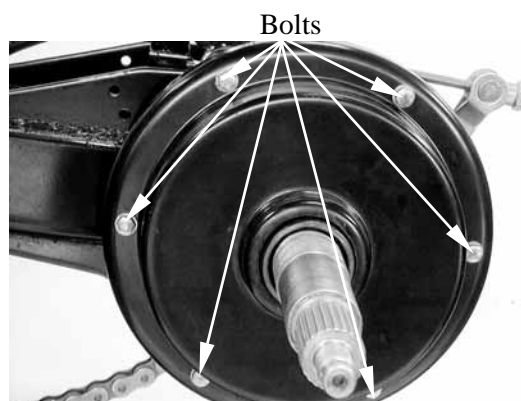

Adjust drive chain slack.
Approximately: 10~20 mm (0.4~0.8 in)



Tighten the bolts.
Torque: 7 kgf-m (70 N-m, 50 lbf-ft)

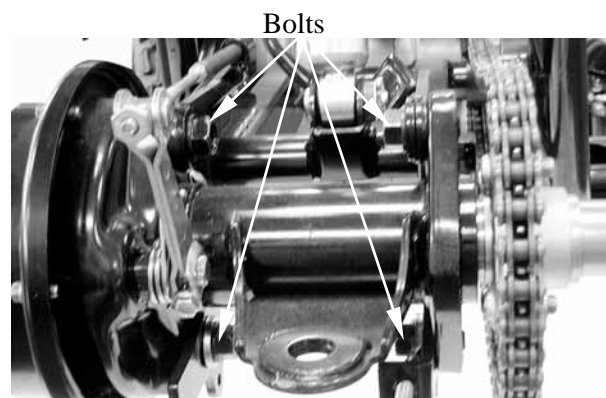

Tighten the lock nut.
Torque: 2 kgf-m (20 N-m, 15 lbf-ft)

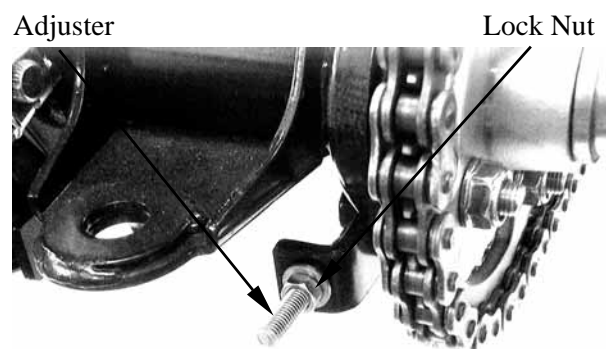

13. REAR WHEEL/SWING ARM/ HYDRAULIC BRAKE

Tighten the two nuts with the nut wrench.

Special tool:

Nut wrench F010

Torque: 12 kgf-m (120 N-m, 86 lbf-ft)

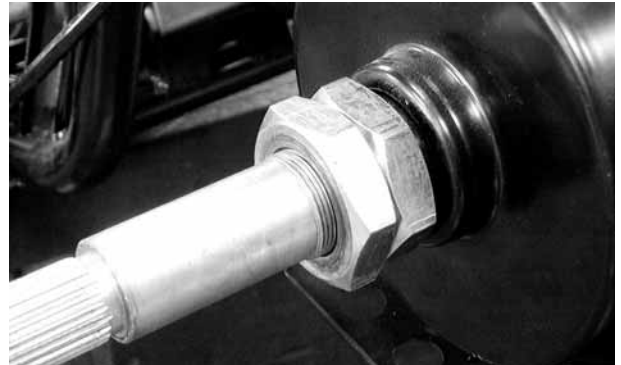

Install wheel hub, plate washer and nut (wheel hub).

Torque: 7 kgf-m (70 N-m, 50 lbf-ft)

Install cotter pins.

*

Do not loosen the axle nut after torque tightening. If the axle nut groove is not aligned with the cotter pin hole, align groove with the hole by tightening it on the axle nut.

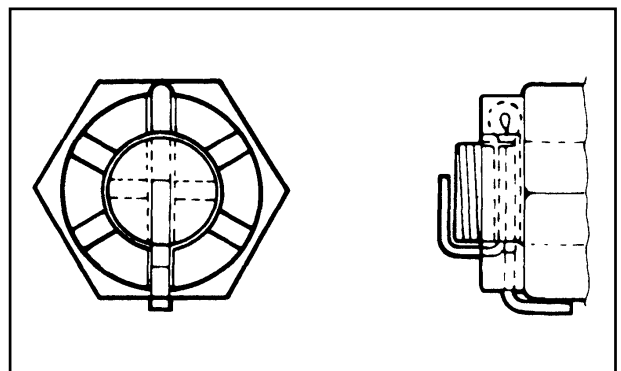

*

Always use a new cotter pin.

When reinstalling a wheel, tighten the wheel nuts in a crisscross (rather than a circular) pattern.

Torque: 4.5 kgf-m (45 N-m, 32 lbf-ft)

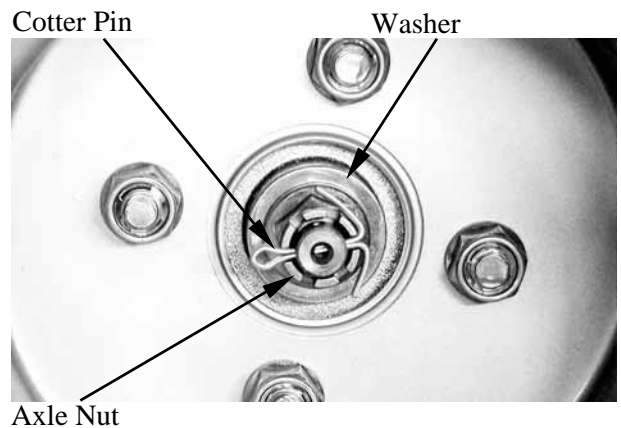

*

MXU 150:

- Tapered wheel nuts are used for rear wheels.
- Install the nuts with its tapered side towards the wheel.

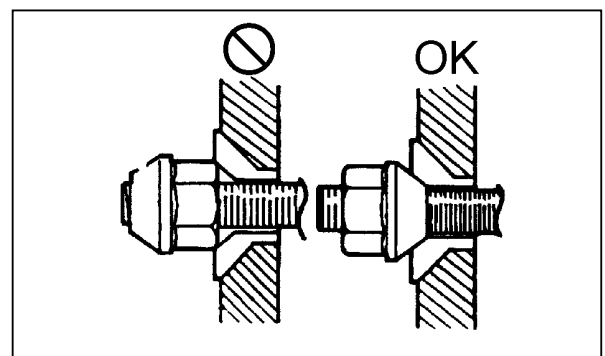

13. REAR WHEEL/SWING ARM/ HYDRAULIC BRAKE

SWING ARM

Place the machine on a level place.

Elevate the rear wheels by placing a suitable stand under the rear of frame.

* Support the machine securely so there is no danger of it falling over.

Remove the rear wheels, rear hub with rear axle.

Refer to the “REAR WHEEL - REMOVAL” section

MXU 150:
Remove the lower mounting bolt.

MX'er 150/125:
Remove the cotter pin, washer and shaft.

* When removing the lower shaft, hold the swing arm so that it does not drop downwards when the shaft is removed.

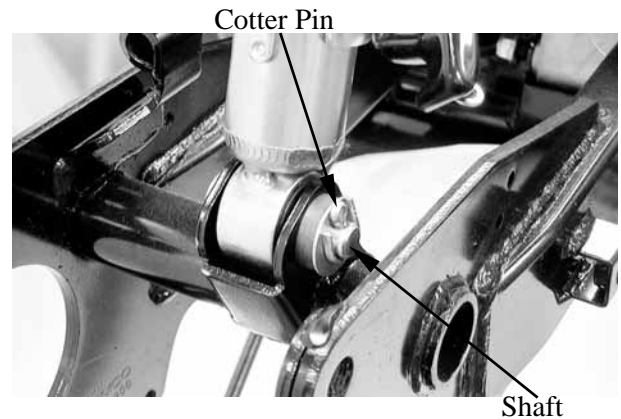

Remove the upper mounting bolt, then remove the shock absorber.

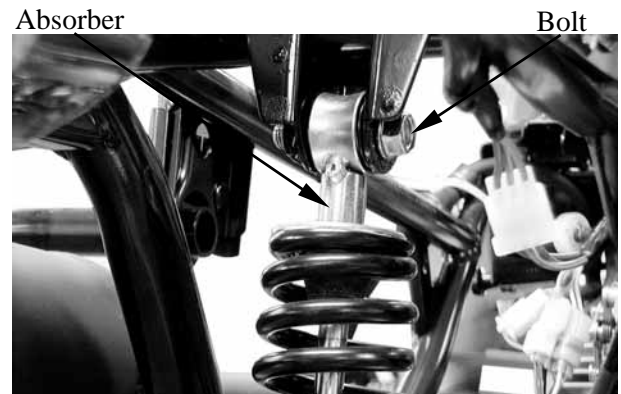

Check the tightening torque of the pivot shaft (swingarm) securing nut.

Torque: 7 kgf-m (70 N-m, 50 lbf-ft)



13. REAR WHEEL/SWING ARM/ HYDRAULIC BRAKE

Check the swing arm side play by moving it from side to side.

If side play noticeable, check the inner collar, bearing, bushing and thrust cover, or adjust the shim.

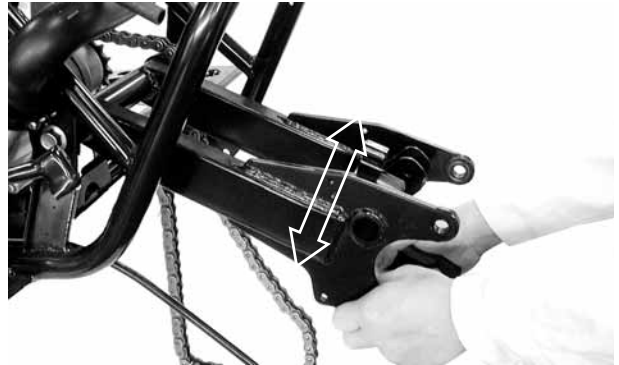

Check the swing arm vertical movement by moving it up and down.

If vertical movement is tight, binding or rough, check the inner collar, bearing, bushing and thrust cover, or adjust the shim.

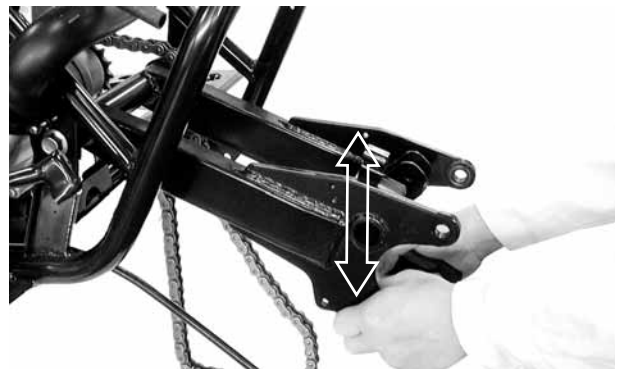

Remove the nut and pivot shaft, then remove swing arm.

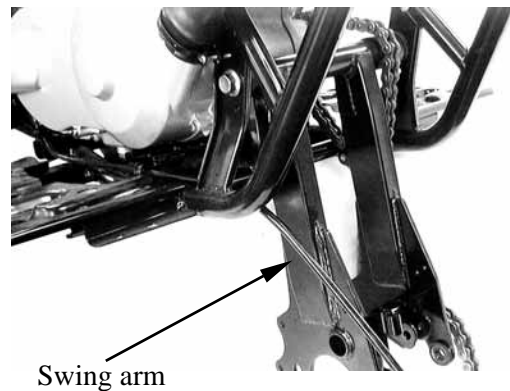

Remove the thrust covers.

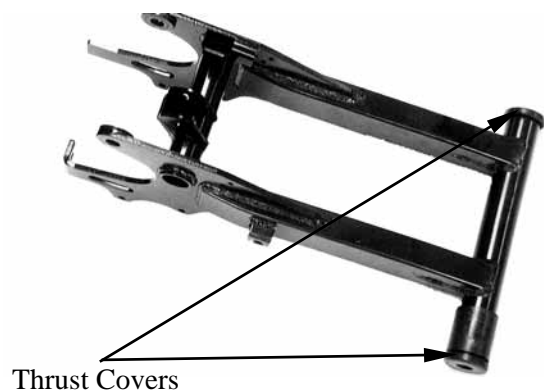

13. REAR WHEEL/SWING ARM/ HYDRAULIC BRAKE

INSPECTION

- Inspect the shock absorber rod.
- Replace the shock absorber assembly if bends or damage.
- Inspect the shock absorber.
- Replace the shock absorber assembly if oil leaks
- Inspect the spring.
- Replace the shock absorber assembly if fatigue.
- Move the spring up and down.

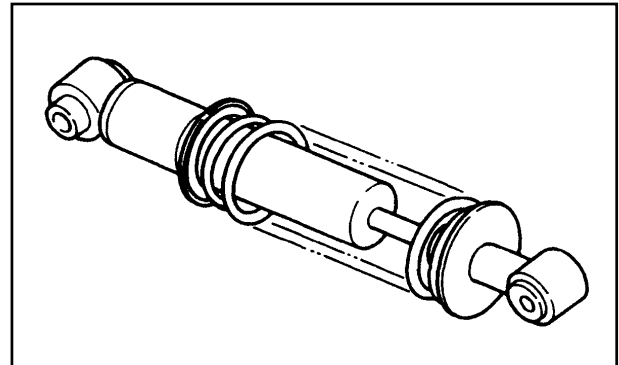

- Inspect the swing arm.
- Replace if crack, bend or damage.
- Roll the axle on a flat surface to inspect the pivot shaft.
- Replace if bends.

* Do not attempt to straighten a bent axle.

- Inspect the thrust cover, chain guard, collar and bush.
- Replace if wear or damage.

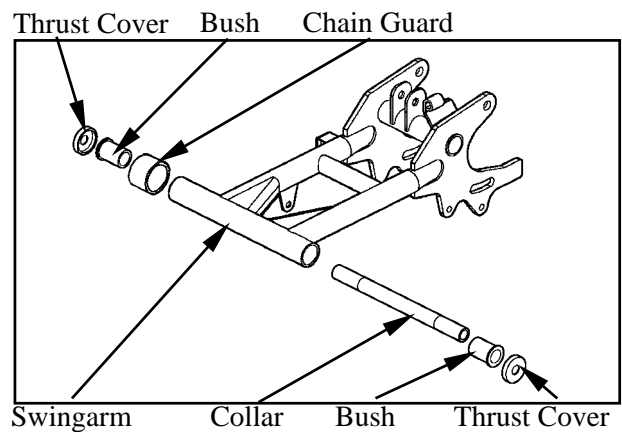

13. REAR WHEEL/SWING ARM/ HYDRAULIC BRAKE

INSTALLATION

Reverse the “REMOVAL” procedure.
Apply grease onto the collar, bush, pivot shaft and thrust cover.
Install the swing arm and tightening the nut.

Torque: 7 kgf-m (70 N-m, 50 lbf-ft)

Pivot Shaft



MXU 150:

Install the shock absorber and tightening the upper and lower mounting bolts.

Torque: 4 kgf-m (40 N-m, 29 lbf-ft)



MX'er 150/125:

Install the shock absorber and tightening the upper mounting bolt.

Torque: 4 kgf-m (40 N-m, 29 lbf-ft)

Install the shaft, washer and cotter pin.

*

Always use a new cotter pin.



Install the rear hub and rear wheels.
Refer to the “REAR WHEEL
INSTALLATION” section.

Adjust the drive chain slack.
Refer to the “DRIVE CHAIN SLACK
ADJUSTMENT” section in the CHAPTER
3.

Approximately: 10~20 mm (0.4~0.8 in)

HYDRAULIC BRAKE

BRAKE FLUID CHANGE/AIR BLEED

Place the motorcycle on its main stand on level ground and set the handlebar upright. Remove the two screws attaching the brake fluid reservoir cap.

★

Use shop towels to cover plastic parts and coated surfaces to avoid damage caused by splash of brake fluid.

Screws



Connect a transparent hose to the brake caliper bleed valve and then loosen the bleed valve nut. Use a syringe to draw the brake fluid out through the hose.

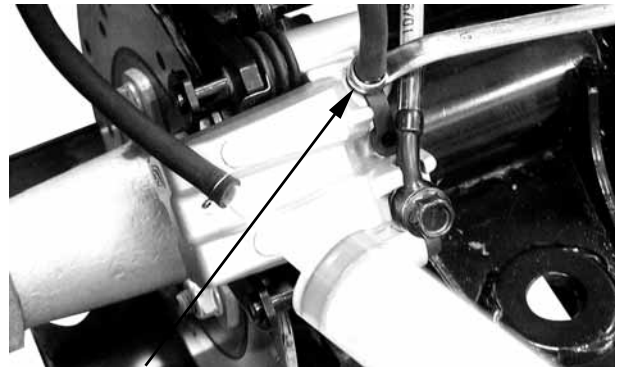

Bleed Valve

BRAKE FLUID REFILLING

Connect a transparent hose and syringe to the brake caliper bleed valve and then loosen the bleed valve nut. Fill the brake reservoir with brake fluid and use the syringe to draw brake fluid into it until there is no air bubbles in the hose. Then, tighten the bleed valve nut.

Torque: 0.6 kgf-m (6 N-m, 4.3 lbf-ft)

★

- When drawing brake fluid with the syringe, the brake fluid level should be kept over 1/2 of the brake reservoir height.
- Use only the recommended brake fluid.

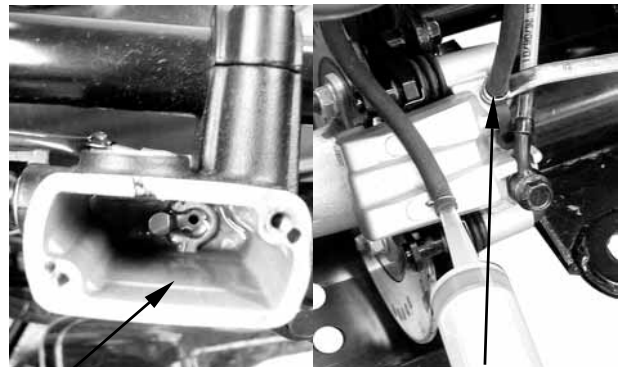

Brake Reservoir

Bleed Valve

Recommended Brake Fluid: DOT-4

13. REAR WHEEL/SWING ARM/ HYDRAULIC BRAKE

Connect a transparent hose to the bleed valve and fully apply the brake lever after continuously pull it several times. Then, loosen the bleed valve nut to bleed air from the brake system. Repeat these steps until the brake system is free of air.

✱

When bleeding air from the brake system, the brake fluid level should be kept over 1/2 of the brake reservoir height.

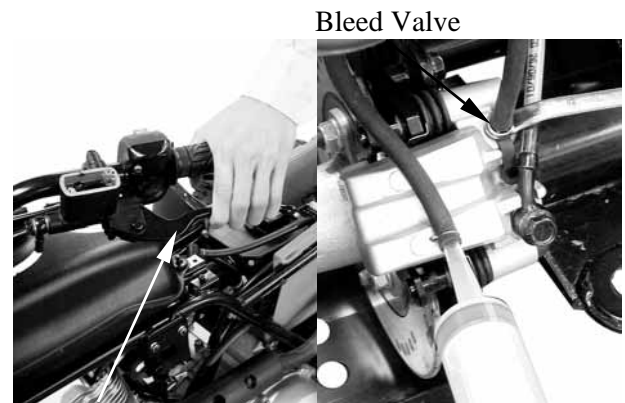

Brake Lever

Bleed Valve

BRAKE PAD/DISK

BRAKE PAD REPLACEMENT

Remove the two bolts attaching the brake caliper holder.

✱

The brake pads can be replaced without removing the brake fluid tube.

Remove the brake caliper.

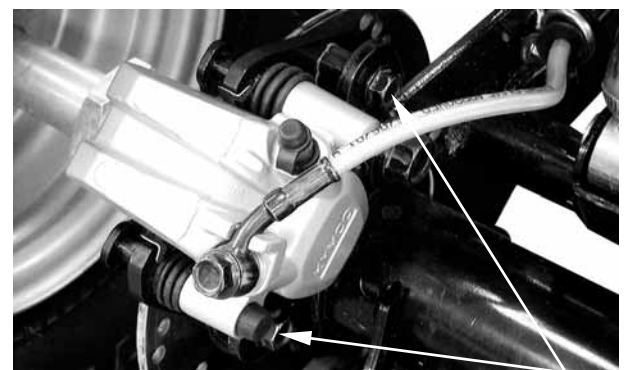

Bolts

Brake Caliper Holder

Brake Pad

Push the brake caliper holder and then remove brake pad.

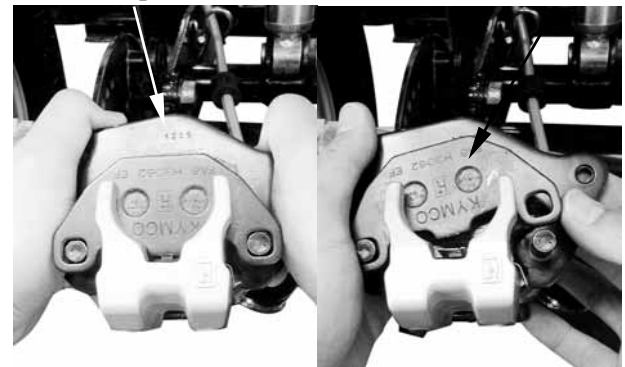

Remove the other brake pad and pad springs.

ASSEMBLY

Assemble the brake pads in the reverse order of removal.

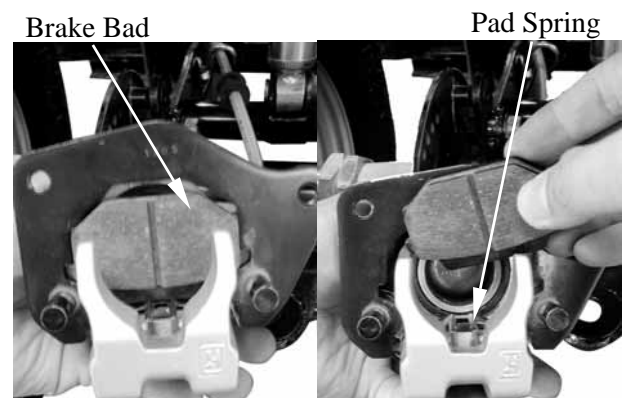

Brake Pad

Pad Spring

13. REAR WHEEL/SWING ARM/ HYDRAULIC BRAKE

BRAKE DISK

Measure the brake disk thickness.

Service Limit: 3 mm (0.12 in)

Measure the brake disk run out.

Service Limit: 0.3 mm (0.012 in)

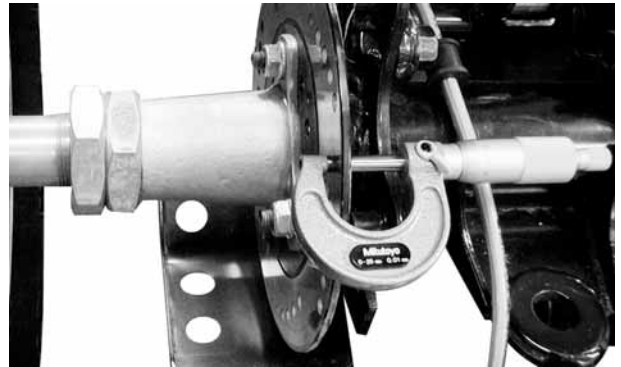

BRAKE MASTER CYLINDER

REMOVAL

Drain the brake fluid from the hydraulic brake system.

* Do not splash brake fluid onto any rubber, plastic and coated parts. When working with brake fluid, use shop towels to cover these parts.

Remove the two master cylinder holder bolts and remove the master cylinder.

* When removing the brake fluid tube bolt, be sure to place towels under the tube and plug the tube end to avoid brake fluid leakage and contamination.

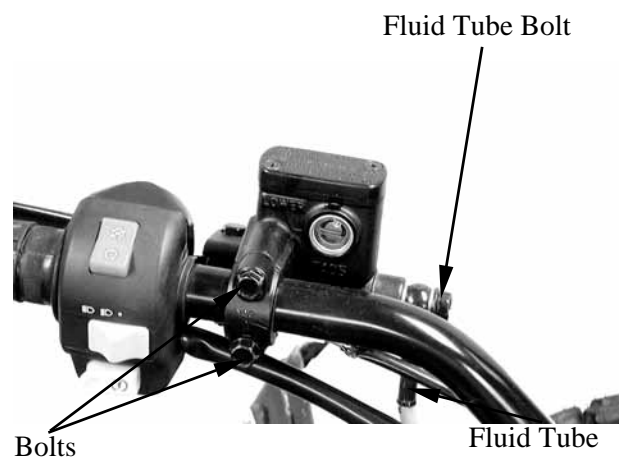

13. REAR WHEEL/SWING ARM/ HYDRAULIC BRAKE

DISASSEMBLY

Remove the piston rubber cover and snap ring from the brake master cylinder.



Snap Ring Pliers

Remove the washer, main piston and spring from the brake master cylinder.
Clean the inside of the master cylinder and brake reservoir with brake fluid.

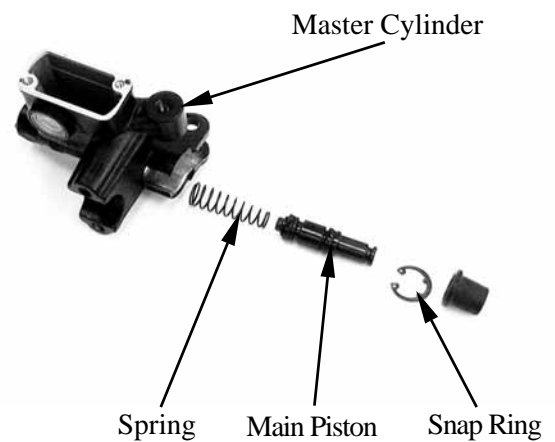

INSPECTION

Measure the brake master cylinder I.D.
Inspect the master cylinder for scratches or cracks.

Service Limit: 12.75 mm (0.51 in)



Measure the brake master cylinder piston O.D.

Service Limit: 12.64 mm (0.5056 in)



13. REAR WHEEL/SWING ARM/ HYDRAULIC BRAKE

ASSEMBLY

Before assembly, apply brake fluid to all removed parts.

Install the spring together with the 1st rubber cup.

★

- During assembly, the master cylinder, main piston and spring must be installed as a unit without exchange.
- When assembling the piston, soak the cups in brake fluid for a while.



Install the main piston and snap ring.
Install the rubber cover.
Install the brake lever.
Install the brake fluid tube with the bolt and two sealing washers. Then, install the rearview mirror.
Fill the brake reservoir with recommended brake fluid to the upper level.
Bleed air from the hydraulic brake system.
(Refer to 13-18.)

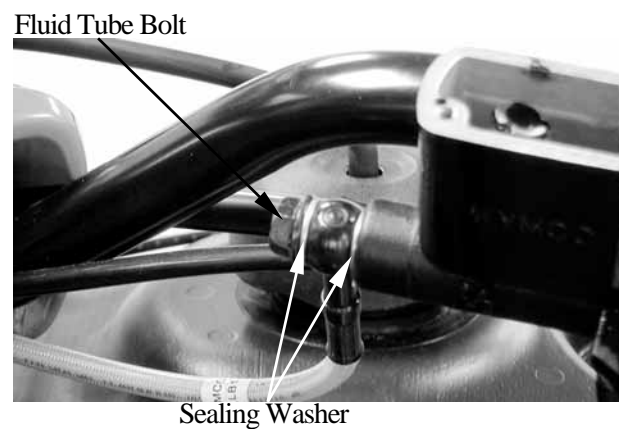

Place the brake master cylinder on the handlebar and install the master cylinder holder with the "UP" mark facing up, aligning the tab on the holder with the hole in the handlebar.
First tighten the upper bolt and then tighten the lower bolt.

Torque: 1.2 kgf-m (12 N-m, 8.6 lbf-ft)



13. REAR WHEEL/SWING ARM/ HYDRAULIC BRAKE

BRAKE CALIPER

REMOVAL

Remove the brake caliper, brake pads and pad spring.
Place a clean container under the brake caliper and disconnect the brake fluid tube from the brake caliper.

★

Be careful not to splash brake fluid on any coated surfaces.



DISASSEMBLY

Remove the brake caliper holder from the brake caliper.

Brake Caliper Holder

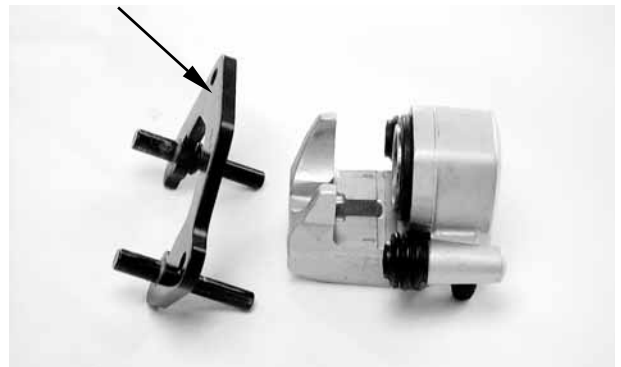

Remove the pistons from the brake caliper.
Use compressed air to press out the pistons through the brake fluid inlet opening and place a shop towel under the caliper to avoid contamination caused by the removed pistons.



Push the piston oil seals inward to remove them.
Clean each oil seal groove with brake fluid.

★

Be careful not to damage the piston surface.

Piston Oil Seals



13. REAR WHEEL/SWING ARM/ HYDRAULIC BRAKE

INSPECTION

Check the piston for scratches or wear.
Measure the piston O.D. with a micrometer gauge.

Service limit: 33.85 mm (1.654 in)



Check the caliper cylinder for scratches or wear and measure the caliper cylinder I.D.

Service limit: 34.05 mm (1.362 in)



ASSEMBLY

Clean all removed parts.

Apply silicon grease to the pistons and oil seals. Lubricate the brake caliper cylinder inside wall with brake fluid.

Install the oil seals and then install the brake caliper pistons with the grooved side facing out.

*

Install the piston with its outer end protruding 3~5mm beyond the brake caliper.



Wipe off excessive brake fluid with a clean shop towel. Apply silicon grease to the brake caliper holder pin and caliper inside. Install the brake caliper holder.

13. REAR WHEEL/SWING ARM/ HYDRAULIC BRAKE

INSTALLATION

Connect the brake fluid tube to the brake caliper, aligning the fluid tube with groove in the caliper and tighten the fluid tube bolt.

Torque: 3.5 kgf-m (35 N-m, 25 lbf-ft)

Add the recommended brake fluid into the brake reservoir and bleed air from the brake system. (Refer to 13-18.)

Install the brake caliper onto rear axle hub and tighten the bolts.

Torque: 3.2 kgf-m (32 N-m, 24 lbf-ft)

Aligning The Fluid Tube With Groove

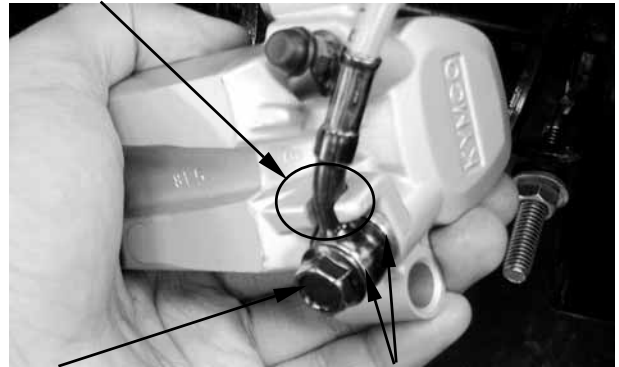

Fluid Tube Bolt

Washer



**BATTER/CHARGING SYSTEM/
A.C. GENERATOR**

SERVICE INFORMATION-----	14- 2
TROUBLESHOOTING-----	14- 3
BATTERY REMOVAL -----	14- 4
CHARGING SYSTEM -----	14- 5
REGULATOR/RECTIFIER-----	14- 6
A.C. GENERATOR CHARGING COIL -----	14- 7

14. BATTERY/CHARGING SYSTEM/ A.C. GENERATOR

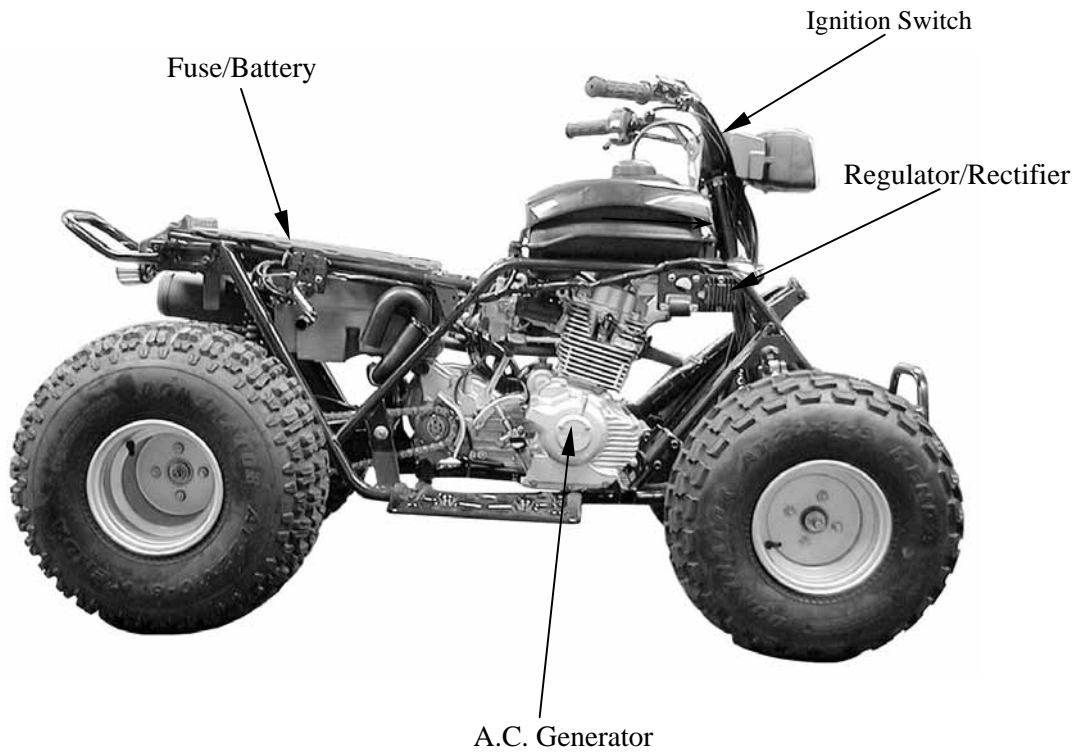

CHARGING CIRCUIT

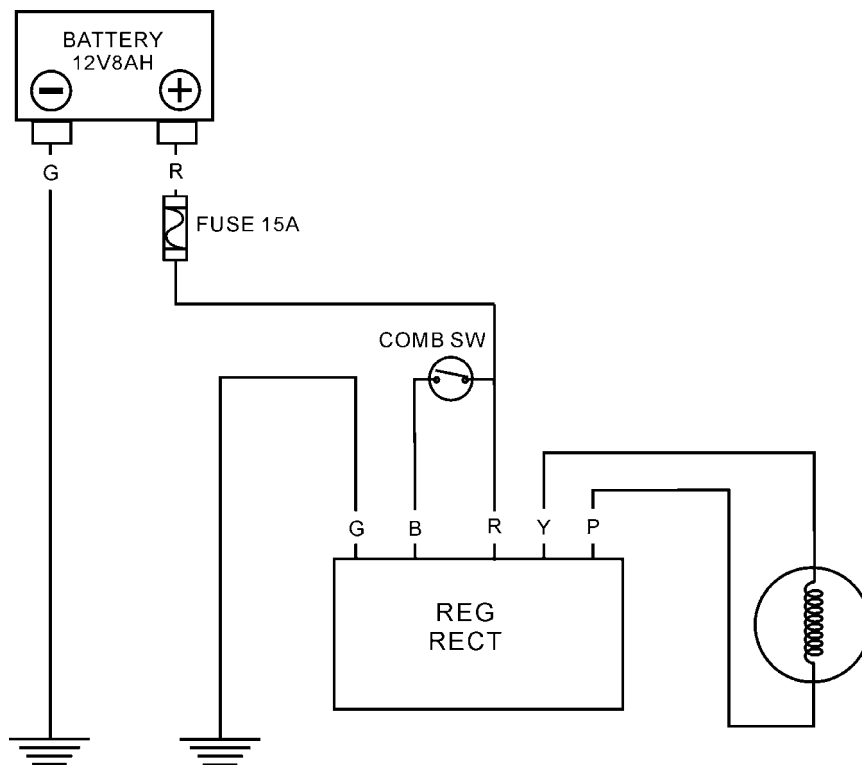

SERVICE INFORMATION

GENERAL INSTRUCTIONS

The battery electrolyte (sulfuric acid) is poisonous and may seriously damage the skin and eyes. Avoid contact with skin, eyes, or clothing. In case of contact, flush with water and get prompt medical attention

- The battery can be charged and discharged repeatedly. If a discharged battery is not used for a long time, its service life will be shortened. Generally, the capacity of a battery will decrease after it is used for 2~3 years. A capacity-decreased battery will resume its voltage after it is recharged but its voltage decreases suddenly and then increases when a load is added.
- When a battery is overcharged, some symptoms can be found. If there is a short circuit inside the battery, no voltage is produced on the battery terminals. If the rectifier won't operate, the voltage will become too high and shorten the battery service life.
- If a battery is not used for a long time, it will discharge by itself and should be recharged every 3 months.
- A new battery filled with electrolyte will generate voltage within a certain time and it should be recharged when the capacity is insufficient. Recharging a new battery will prolong its service life.
- Inspect the charging system according to the sequence specified in the Troubleshooting.
- Do not disconnect and soon reconnect the power of any electrical equipment because the electronic parts in the regulator/rectifier will be damaged. Turn off the ignition switch before operation.
- It is not necessary to check the MF battery electrolyte or fill with distilled water.
- Check the load of the whole charging system.
- Do not quick charge the battery. Quick charging should only be done in an emergency.
- Remove the battery from the motorcycle for charging.
- When replacing the battery, do not use a traditional battery.
- When charging, check the voltage with a voltmeter.

SPECIFICATIONS

Item		Standard	
Battery	Capacity/Model	12 V-8 AH	
	Voltage (20°C)	Fully charged	13.1 V
		Undercharged	12.3 V
	Charging current	STD: 0.9 A Quick: 3 A	
	Charging time	STD: 5~10 hr Quick: 30 min	
A.C. Generator	Capacity	0.114 KW/5000 rpm	
	Charging coil resistance (20°C)	Yellow~Pink	
Regulator/Rectifier	Type	Single-phase half-wave SCR	
	Limit voltage	Lighting	12~14 V/5000 rpm (Electric tester, tachometer)
		Charging	10~13 V/5000 rpm
		13.5~15.5 V/5000 rpm	

TORQUE VALUES

Regulator/Rectifier lock nut 0.9 kgf-m (9 N-m, 6.5lbf-ft)

TESTING INSTRUMENTS

Kowa electric tester

Sanwa electric tester

TROUBLESHOOTING

No power

- Dead battery
- Disconnected battery cable
- Fuse burned out
- Faulty ignition switch

Low power

- Weak battery
- Loose battery connection
- Charging system failure
- Faulty regulator/rectifier

Intermittent power

- Loose battery cable connection
- Loose charging system connection
- Loose connection or short circuit in lighting system

Charging system failure

- Loose, broken or shorted wire or connector
- Faulty regulator/rectifier
- Faulty A.C. generator

BATTERY REMOVAL

Pull backward the lock lever, then pull up the seat at the rear.

Remove the battery by removing the bolt. First disconnect the battery negative (-) cable and then the positive (+) cable.

 When disconnecting the battery positive (+) cable, do not touch the frame with tool; otherwise it will cause short circuit and sparks to fire the fuel.

The installation sequence is the reverse of removal.

 First connect the positive (+) cable and then negative (-) cable to avoid short circuit.

BATTERY VOLTAGE (OPEN CIRCUIT VOLTAGE) INSPECTION

Remove the seat.

Disconnect the battery cables.

Measure the voltage between the battery terminals.

Fully charged : 13.1 V

Undercharged : 12.3 V max

* Battery charging inspection must be performed with a voltmeter.

CHARGING

Connect the charger positive (+) cable to the battery positive (+) terminal.

Connect the charger negative (-) cable to the battery negative (-) terminal.

 • Keep flames and sparks away from a charging battery.
• Turn power ON/OFF at the charger, not at the battery terminals to prevent sparks near the battery to avoid explosion.
• Charge the battery according to the

* • Quick charging should only be done in an emergency.
• Measure the voltage 30 minutes after the battery is charged.

Charging current: Standard : 0.9 A

Quick : 3 A

Charging time : Standard : 5 ~ 10 hours

Quick : 30 minutes

After charging: Open circuit voltage: 12.8 V min.

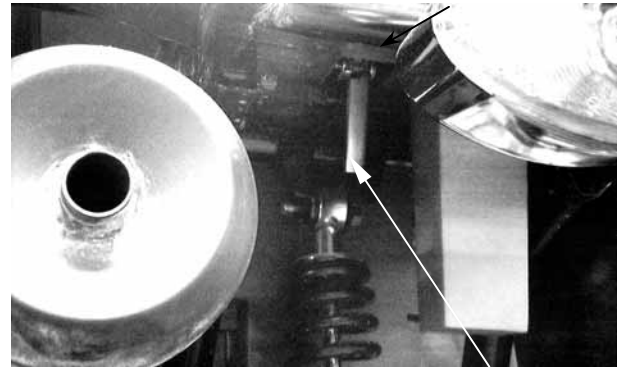

Lock Lever



CHARGING SYSTEM

SHORT CIRCUIT TEST

Disconnect the ground wire from the battery and connect an ammeter across the battery negative (-) terminal and the ground wire. Turn the ignition switch OFF and check for short circuit.

- * Connect the electric tester positive (+) terminal to ground wire and the tester negative (-) terminal to the battery negative (-) terminal.

If any abnormality is found, check the ignition switch and wire harness for short circuit.

CURRENT TEST

This inspection must be performed with an electric tester when the battery is fully charged.

Warm up the engine for inspection.

Connect the electric tester across the battery terminals. Disconnect the red wire from the fuse terminal and connect an ammeter between the red wire lead and the fuse terminal as shown.

Attach a tachometer to the engine.

Start the engine and gradually increase the engine speed to measure the limit voltage and current.

Limit Voltage/Current:

13.5 ~ 15.5 V / 0.5 A max. (5000 rpm max.)

If the limit voltage is not within the specified range, check the regulator/rectifier.

LIGHTING SYSTEM LIMIT VOLTAGE INSPECTION

Remove the front cover.

- * Measure the voltage with the electric tester in the DC range.

Limit Voltage: 14.7±0.4 V

If the limit voltage is not within the specified range, check the regulator/rectifier.

PERFORMANCE TEST

Position \ RPM	3000	8000
	Day	4 A 16 V
Night	1.1 A 14 V (1.0A min.)	2.1 A 14 V (3.7 A max.)

Perform this test with a fully charged battery.



(-) Terminal



Headlight Wire Coupler

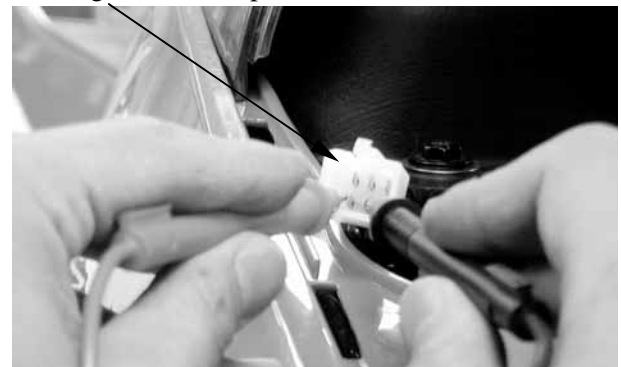

REGULATOR/RECTIFIER

MAIN HARNESS CIRCUIT INSPECTION

Remove the front fender.
Remove the regulator/rectifier lock nuts and 5P coupler.

Regulator/Rectifier

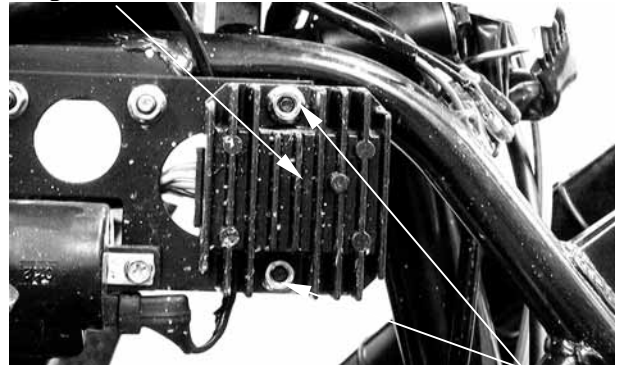

Lock Nut

REGULATOR/RECTIFIER INSPECTION

If the main harness terminals are normal, check the regulator/rectifier coupler for loose connection and measure the resistance between the regulator/rectifier terminals.

- Do not touch the tester probes with your finger because human body has resistance.
- Use the following specified testers for accurate testing. Use of an improper tester in an improper range may give false readings.
 - Kowa Electric Tester
 - Sanwa Electric Tester
 - Kowa Electric Tester TH-5H
- Proper range for testing:
 - Use $XK\Omega$ range for Sanwa Tester
 - Use $X100\Omega$ range for Kowa Tester
- If the dry battery in the tester is weak, the readings will be incorrect. In this case, check the dry battery.
- The Kowa tester readings are 100 times the actual values. Be careful during testing.

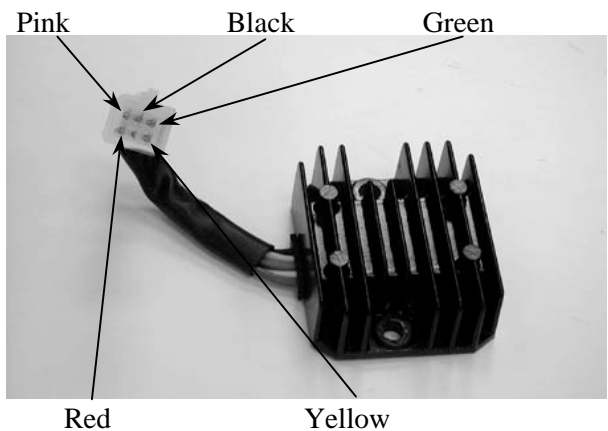

Probe [⊕] Probe(-)	Black	Pink	Red	Yellow	Green
Black		4-7K	13-17K	4-7K	1-2K
Pink	∞		4-7K	∞	∞
Red	∞	∞		∞	∞
Yellow	∞	∞	4-7K		∞
Green	1-2K	4-6K	13-17K	4-6K	

Replace the regulator/rectifier if the readings are not within the specifications in the table.

A.C. GENERATOR CHARGING COIL

* The inspection of A.C. generator charging coil can be made with the engine installed.

INSPECTION

Disconnect the A.C. generator pink and yellow wires and measure the resistance between the pink and yellow wires.

Resistance: 0.2 Ω (at 20°C)

Replace the A.C. generator charging coil if the reading is not within the specifications.



IGNITION SYSTEM

SERVICE INFORMATION-----	15- 2
TROUBLESHOOTING-----	15- 3
CDI UNIT INSPECTION-----	15- 4
IGNITION COIL INSPECTION -----	15- 6
PULSER COIL -----	15- 7

15. IGNITION SYSTEM

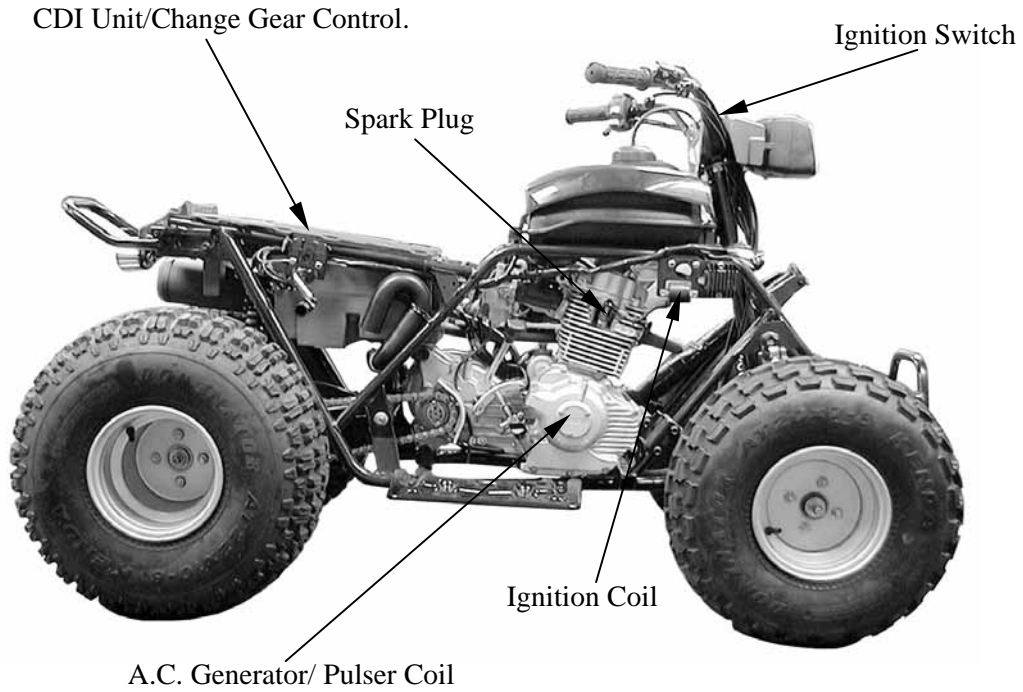

IGNITION CIRCUIT

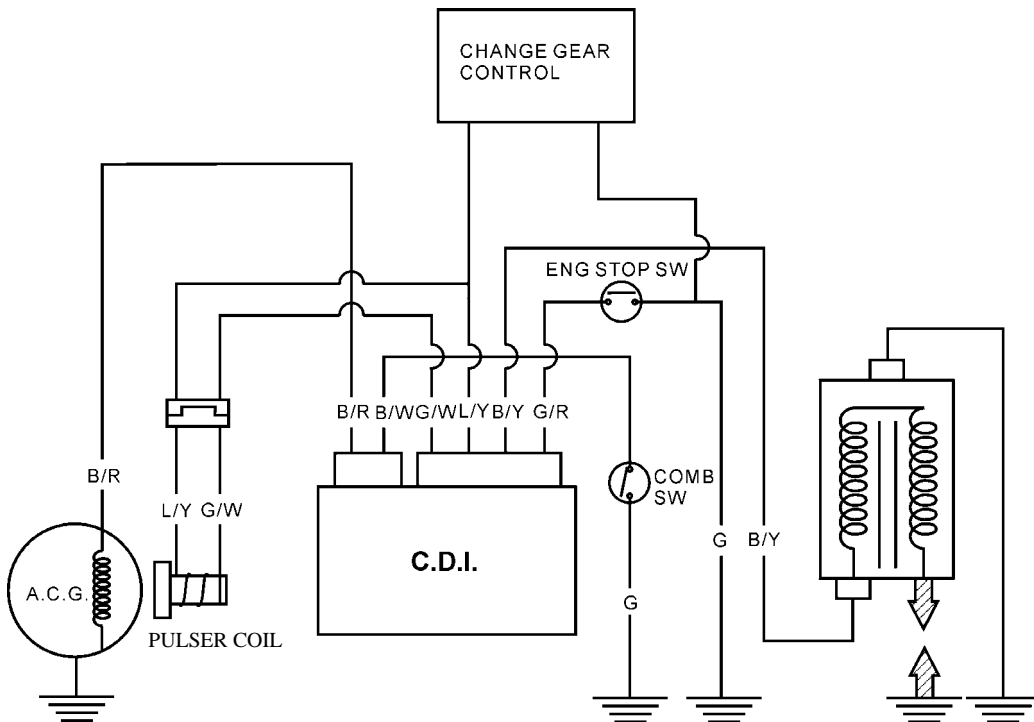

15. IGNITION SYSTEM

SERVICE INFORMATION

GENERAL INSTRUCTIONS

- Check the ignition system according to the sequence specified in the Troubleshooting.
- The ignition system adopts CDI unit , change gear control and the ignition timing cannot be adjusted.
- If the timing is incorrect, inspect the CDI unit, A.C. generator, change gear control and replace any faulty parts. Inspect the CDI unit with a CDI tester
- Loose connector and poor wire connection are the main causes of faulty ignition system. Check each connector before operation.
- Use of spark plug with improper heat range is the main cause of poor engine performance.
- The inspections in this section are focused on maximum voltage. The inspection of ignition coil resistance is also described in this section.
- Inspect the ignition switch according to the continuity table specified in page 17-5.
- Inspect the spark plug referring to Section 3.

SPECIFICATIONS

Item		Standard	
Spark plug	Standard type	CR8E	
	Hot type		
	Cold type		
Spark plug gap		0.6~0.7 mm (0.024~0.028 in)	
Ignition timing	“F” mark Full advance	15°BTDC/1,700±100 rpm	
Ignition coil resistance (20°C)	Primary coil		0.2~0.3 Ω
	Secondary coil	with plug cap	3.2~4.8 KΩ
		plug cap	4.2~5.2 KΩ
Pulser coil resistance (20°C)		50~60 Ω	
Exciter coil resistance (20°C)		100~120 Ω	
Ignition coil primary side max. voltage		12 V min.	
Pulser coil max. voltage		2.1 V min.	

TESTING INSTRUMENT

Kowa Electric Tester

or commercially available electric tester with resistance over 10MΩ/CDV

15. IGNITION SYSTEM

TROUBLESHOOTING

High voltage too low

- Weak battery or low engine speed
- Loose ignition system connection
- Faulty CDI unit
- Faulty ignition coil
- Faulty pulser coil

Normal high voltage but no spark at plug

- Faulty spark plug
- Electric leakage in ignition secondary circuit
- Faulty ignition coil

Good spark at plug but engine won't start

- Faulty CDI or incorrect ignition timing
- Faulty change gear control unit
- Improperly tightened A.C. generator flywheel

No high voltage

- Faulty ignition switch
- Faulty CDI unit
- Poorly connected or broken CDI ground wire
- Dead battery or faulty regulator/rectifier
- Faulty ignition coil connector
- Faulty pulser coil

15. IGNITION SYSTEM

CDI UNIT INSPECTION

Remove the seat.
Disconnect the CDI coupler and remove the CDI unit.
Measure the resistance between the terminals using the electric tester.

- *
- Due to the semiconductor in circuit, it is necessary to use a specified tester for accurate testing. Use of an improper tester in an improper range may give false readings.
 - Use a Sanwa Electric Tester or Kowa Electric Tester.
 - In this table, “Needle swings then returns” indicates that there is a charging current applied to a condenser. The needle will then remain at “∞” unless the condenser is discharged.

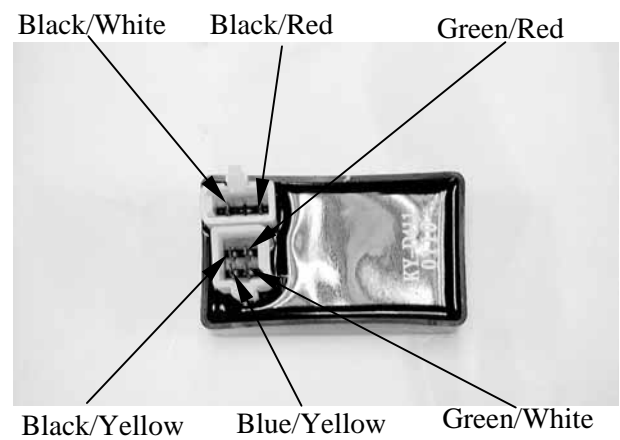
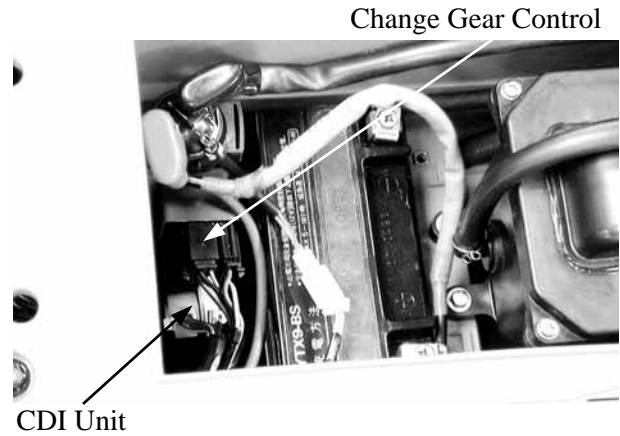

Testing Range

Use the xKΩ range for the Sanwa Tester.
Use the xKΩ range for the Kowa Tester.

Unit: KΩ

Probe⊕ (-)Probe	Black/ White	Black/ Red	Blue/ White	Green	Green/ White	Black/ Yellow
Black/ White		∞	∞	∞	∞	∞
Black/ Red	3-6K		Needle Swings then ∞	Needle Swings then ∞	∞	∞
Blue/ White	35-42K	18-22K		8-10K	8-10K	∞
Green	15-18K	4.5-5.5K	7-9K		There is continuity	∞
Green/ White	15-18K	4.5-5.5K	8-9K	There is continuity		∞
Black/ Yellow	∞	∞	∞	∞	∞	

Note: The readings in this table are taken with a Sanwa Tester.

15. IGNITION SYSTEM

Test the CDI unit using the CDI tester.

* Operate the CDI tester by following the manufacturer's instructions.

Connect the special connector to the CDI coupler and CDI tester.

Switch Range	Good CDI	Faulty CDI
1. OFF	No spark	—
2. P	No spark	—
3. EXT	No spark	Good spark
4. ON1	Good spark	No spark
5. ON2	Good spark	No spark

If the CDI unit is faulty, replace it with a new one.

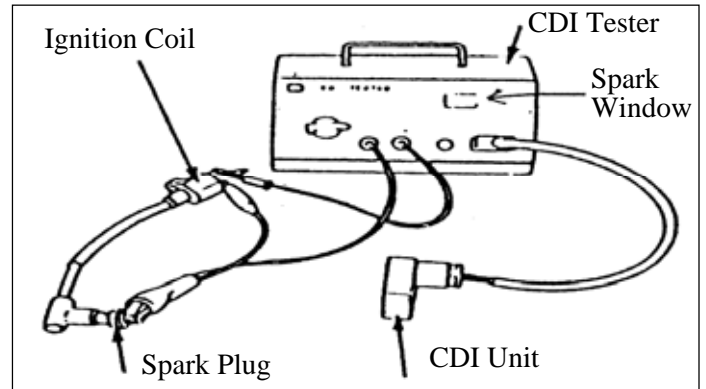

Remove the seat.
Disconnect the change gear control coupler and remove the change gear control unit.
Measure the resistance between the terminals using the electric tester.

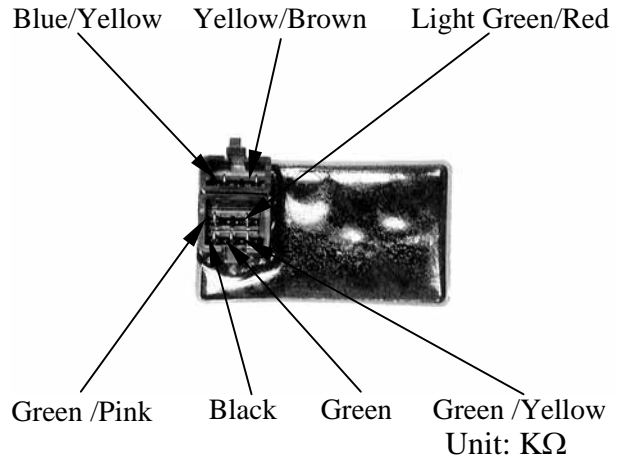

Testing Range

Use the xKΩ range for the Sanwa Tester.

Use the xKΩ range for the Kowa Tester.

Probe⊕ (-)Probe	Black	Green	Green/ Yellow	Green/ Pink	Light Green/ Red	Blue/ Yellow	Yellow/ Brown
Black		5-50K	5-50K	5-50K	5-50K	5-50K	5-50K
Green	∞		5-50K	5-50K	5-50K	5-50K	0
Green/ Yellow	∞	5-50K		10-50K	10-50K	10-50K	5-50K
Green/ Pink	∞	∞	∞		0	∞	∞
Light Green/ Red	∞	∞	∞	0		∞	∞
Blue/ Yellow	∞	50-200K	50-200K	50-200K	50-200K		
Yellow/ Brown	∞	0	5-50K	5-50K	5-50K	5-50K	

Note: The readings in this table are taken with a Sanwa Tester.

15. IGNITION SYSTEM

IGNITION COIL INSPECTION CONTINUITY TEST

Remove the front cover.
Remove the spark plug cap.
Disconnect the ignition coil wires.

* This test is to inspect the continuity of ignition coil.

Measure the resistance between the ignition coil primary coil terminals.

Resistance: 0.2~0.3 Ω/20°C

Remove the spark plug cap and measure the secondary coil resistance between the spark plug wire and the primary coil terminal.

Resistance: 3.2~4.8 KΩ/20°C

* This test is for reference only. Accurate test should be performed with a CDI tester.

Ignition Coil



Measure the spark plug cap resistance.
Remove the spark plug cap and measure the spark plug resistance.

Resistance: 4.2~5.2 KΩ/20°C

* Measure the resistance in the XKΩ range of the electric tester.



PERFORMANCE TEST

Test the performance with a CDI tester.

*

- Operate the CDI tester by following the manufacturer's instructions.
- Use the special connector to connect the CDI unit.

If the spark is weak, inspect the spark plug and CDI unit. If both of them are normal, replace the ignition coil with a new one.

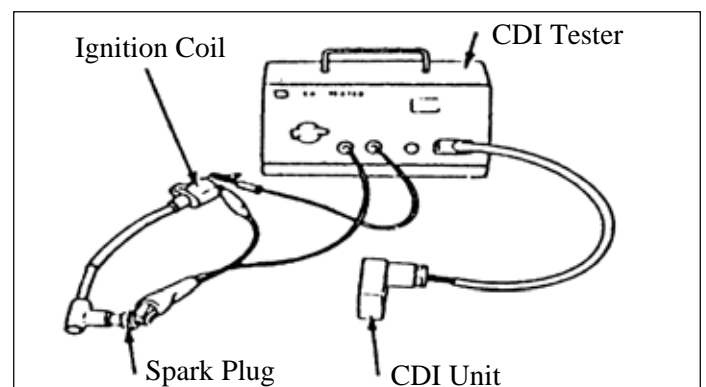

15. IGNITION SYSTEM

PULSER COIL

INSPECTION

Remove the front cover.

Disconnect the pulser coil wire coupler and measure the resistance between the blue/yellow and green/white wire terminals.

Resistance: 50~60 Ω



EXCITER COIL

INSPECTION

Disconnect the exciter coil wire coupler and measure the resistance between the black/red wire terminal and ground.

Resistance: 100~120 Ω

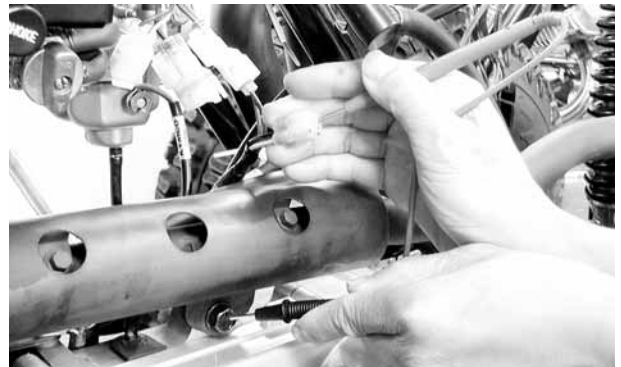

16. STARTING SYSTEM

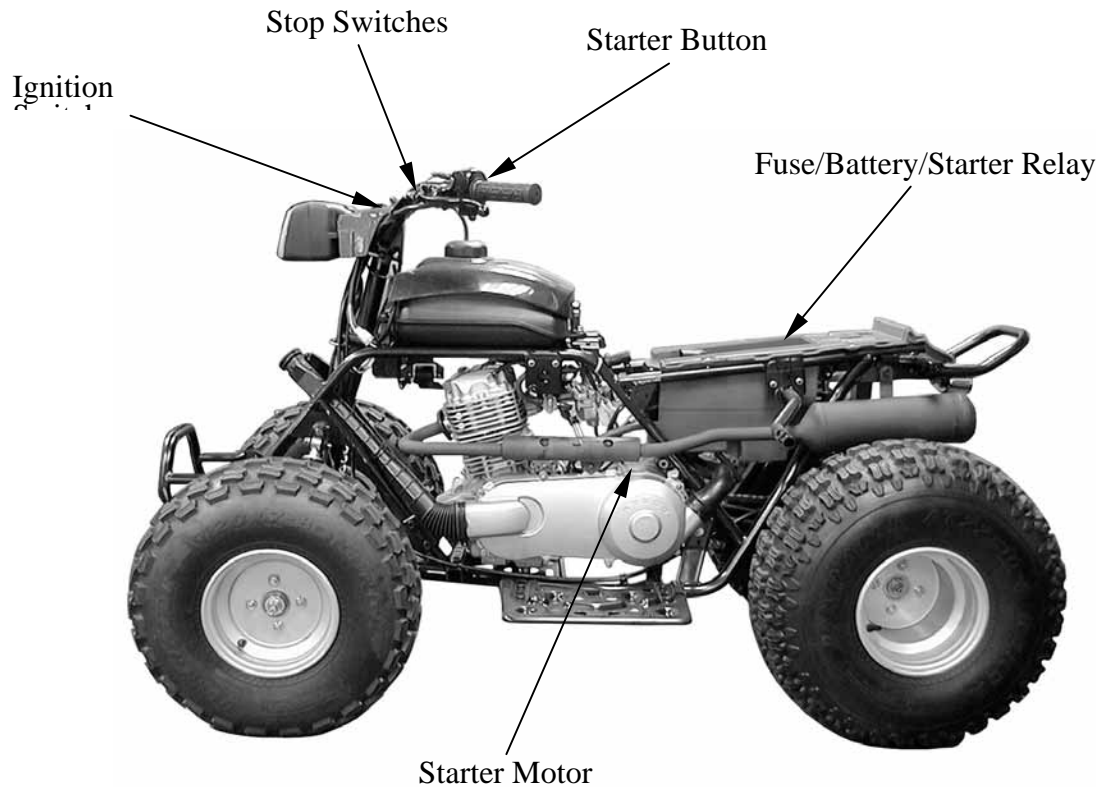

STARTING CIRCUIT

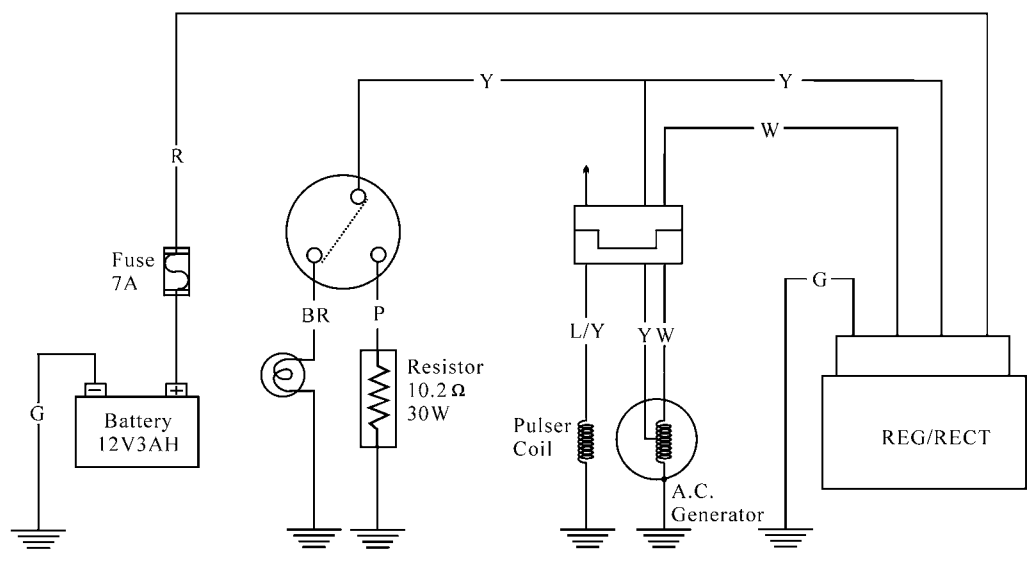

16. STARTING SYSTEM

SERVICE INFORMATION

GENERAL INSTRUCTIONS

- The removal of starter motor can be accomplished with the engine installed.
- For the starter clutch removal, refer to Section 4.

SPECIFICATIONS

mm (in)

Item	Standard	Service Limit
Starter motor brush length	12.5 (0.5)	8.5 (0.34)

TROUBLESHOOTING

Starter motor won't turn

- Fuse burned out
- Weak battery
- Faulty ignition switch
- Faulty starter clutch
- Faulty front or rear stop switch
- Faulty starter relay
- Poorly connected, broken or shorted wire
- Faulty starter motor

Lack of power

- Weak battery
- Loose wire or connection
- Foreign matter stuck in starter motor or gear

Starter motor rotates but engine does not start

- Faulty starter clutch
- Starter motor rotates reversely
- Weak battery

16. STARTING SYSTEM

STARTER MOTOR

REMOVAL

★ Before removing the starter motor, turn the ignition switch OFF and remove the battery ground. Then, turn on the ignition switch and push the starter button to see if the starter motor operates properly.

Remove the two starter motor mounting bolts and the motor.

Remove the waterproof rubber jacket and disconnect the starter motor cable connector.

DISASSEMBLY

Remove the two starter motor case screws, front cover, motor case and other parts.

INSPECTION

Inspect the removed parts for wear, damage or discoloration and replace if necessary. Clean the commutator if there is metal powder between the segments.

Check for continuity between pairs of the commutator segments and there should be continuity.

Also, make a continuity check between individual commutator segments and the armature shaft. There should be no continuity.



Starter Motor Cable

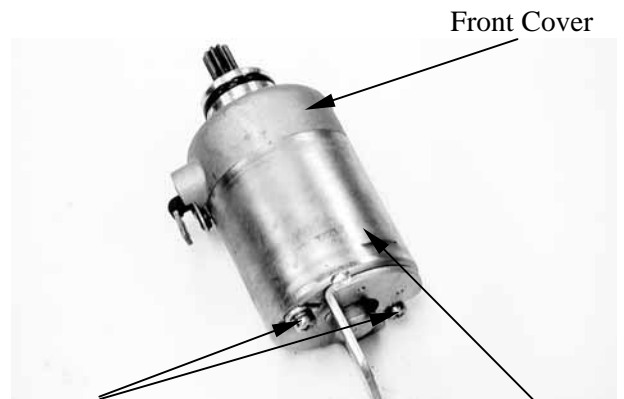

Case Screws

Motor Case



Commutator

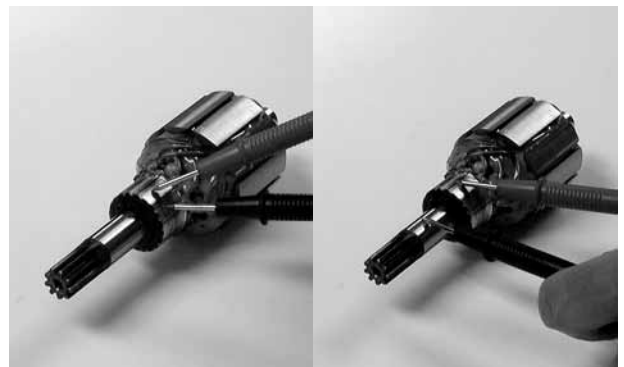

16. STARTING SYSTEM

STARTER MOTOR CASE CONTINUITY CHECK

Check to confirm that there is no continuity between the starter motor wire terminal and the motor front cover.

Also check for the continuity between the wire terminal and each brush.

Replace if necessary.



Wire Terminal

Measure the length of the brushes.

Service Limit: 8.5mm replace if below



Check for continuity between the brushes. If there is continuity, replace with new ones.



Check if the needle bearing in the front cover turns freely and has no excessive play.

Replace if necessary.

Check the dust seal for wear or damage.

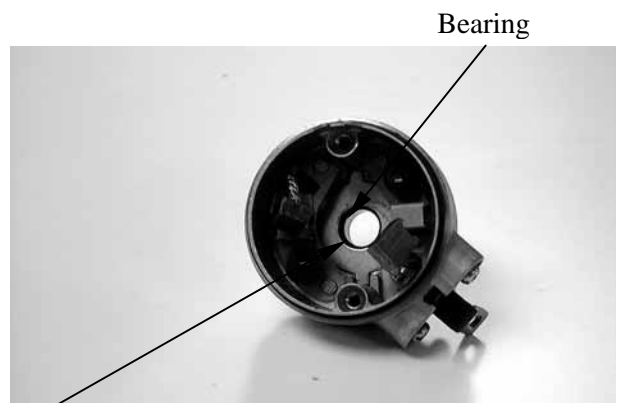

Dust Seal

Bearing

16. STARTING SYSTEM

ASSEMBLY

Apply grease to the dust seal in the front cover.
Install the brushes onto the brush holders.
Apply a thin coat of grease to the two ends of the armature shaft.
Insert the commutator into the front cover.

- ★
- Be careful not to damage the brush and armature shaft mating surfaces.
 - When installing the commutator, the armature shaft should not damage the dust seal lip.

Install a new O-ring to the front cover.
Install the starter motor case, aligning the tab on the motor case with the groove on the front cover.
Tighten the starter motor case screws.

- ★
- When assembling the front cover and motor case, slightly press down the armature shaft to assemble them.

Commutator

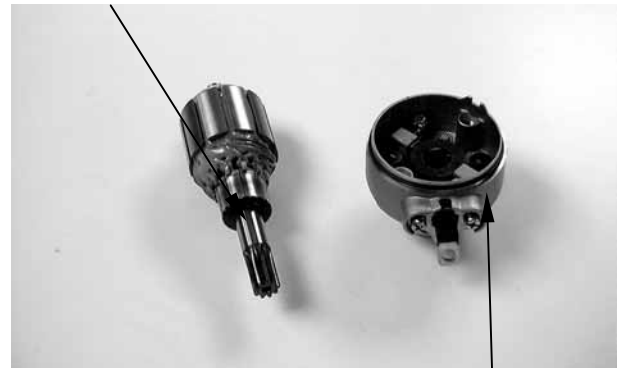

Front Cover

Tab Groove O-ring



Motor Case

Starter Relay

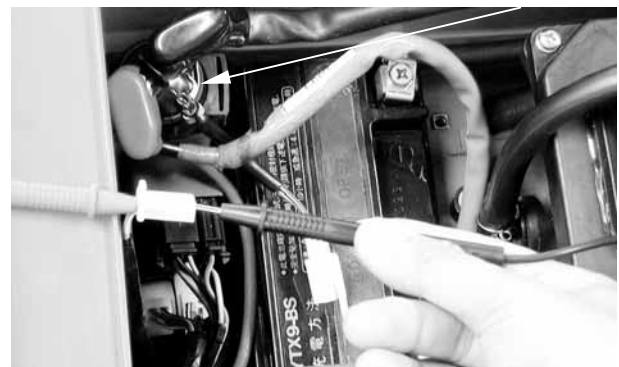

STARTER RELAY

INSPECTION

Remove the seat.
Turn the ignition switch ON and the starter relay is normal if you hear a click when the starter button is depressed.
If there is no click sound:

- Inspect the starter relay voltage
- Inspect the starter relay ground circuit
- Check for continuity between the starter relay yellow/red and green/red wire terminals

STARTER RELAY VOLTAGE INSPECTION

Connect a 12 V battery across the starter relay yellow/red and green/red wire terminals.
Connect an electric tester between the starter relay large terminals and check for continuity between the two terminals.
The relay is normal if there is continuity.
Replace the starter relay with a new one if there is no continuity.



16. STARTING SYSTEM

STARTER MOTOR INSTALLATION

Connect the starter motor cable connector and properly install the waterproof rubber jacket.

Check the O-ring for wear or damage and replace if necessary.

Apply grease to the O-ring and install the starter motor.

Tighten the two mounting bolts.

★

The starter motor cable connector must be installed properly.



O-ring

17. LIGHTS/ SWITCHES

LIGHTS/SWITCHES

SERVICE INFORMATION-----	17- 1
TROUBLESHOOTING-----	17- 1
HEADLIGHT (MX'er 150/125) -----	17- 2
HEADLIGHT (MXU 150)-----	17- 3
POSITION LIGHT (MXU 150) -----	17- 4
INSTRUMENTS (MX'er 150/125)/STOP LIGHT/TAILLIGHT -----	17- 4
IGNITION SWITCH -----	17- 5
STOP SWITCH -----	17- 6
HANDLEBAR SWITCH (MX'er 150/125)-----	17- 7
HANDLEBAR SWITCH (MXU 150) -----	17- 8
NEUTRAL/REVERSE SWITCHES -----	17- 9

17. LIGHTS/ SWITCHES

SERVICE INFORMATION

GENERAL INSTRUCTIONS

- An electric tester is needed to measure or test the electric equipment.
- Be sure to use fuses and bulbs of the same specifications to avoid damage of electrical equipment.
- After installation of each switch, a continuity check must be performed. A continuity check can usually be made without removing the part from the motorcycle.

TROUBLESHOOTING

Lights do not come on when ignition switch is “ON”

- Faulty ignition switch
- Fuse burned out
- Weak battery
- Burned bulb
- Faulty switch
- Poorly connected, broken or shorted wire

Engine starts but stalls during idling

- Clogged carburetor

17. LIGHTS/ SWITCHES

HEADLIGHT (MX'er 150/125) BULB REPLACEMENT

Disconnect the cover of the ignition switch and remove the two headlight attaching bolts.

Remove the headlight and disconnect the headlight wire coupler.

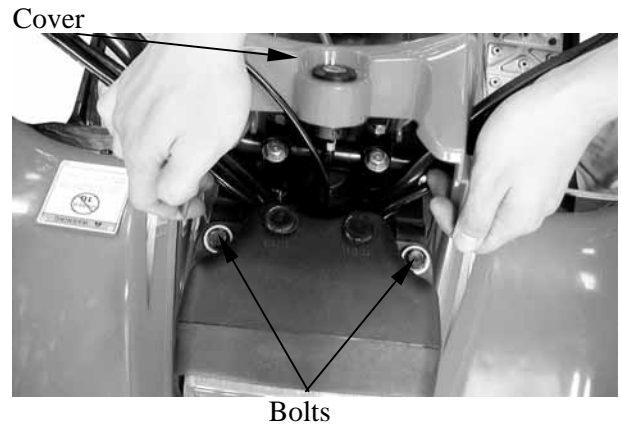

Remove the two headlight case attaching screws and disconnect the headlight.



Check the bulb for damage and replace with a new one if necessary.

Disconnect the headlight wire coupler.

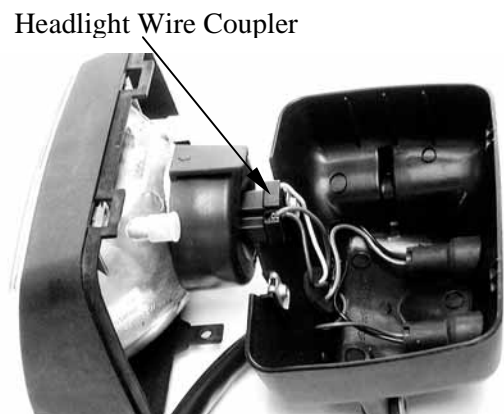

Remove the rubber boot.

Push and disconnect the spring from the headlight cover.

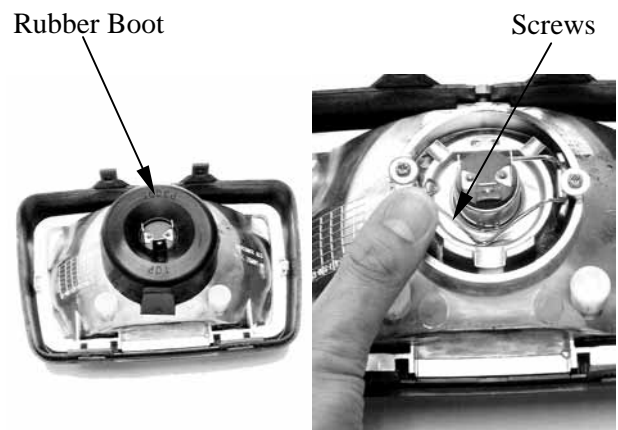

17. LIGHTS/ SWITCHES

Remove the headlight bulb

INSTALLATION

Install the headlight in the reverse order of removal.

* After installation, adjust the headlight beam.

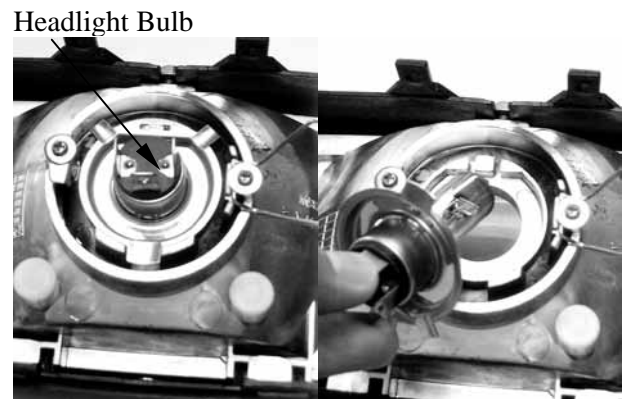

HEADLIGHT (MXU 150)

HEADLIGHT

Remove the front fender. (See page 2-13.)

Remove the rubber boot from the headlight case.

Disconnect the headlight wire connector.

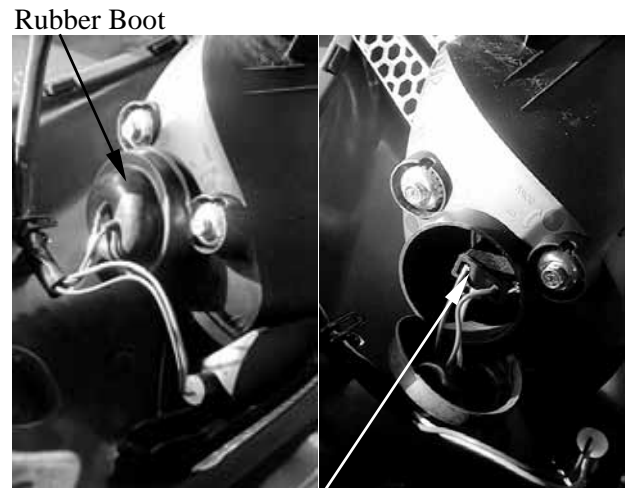

Headlight Connector

Relax the lock clips to remove the bulb and replace with a new one.

Install the bulb, aligning the bulb socket groove with the bulb tab and set the lock clips.

Connect headlight wire connector.

Install the rubber boot.

Install the front fender in the reverse order of removal.

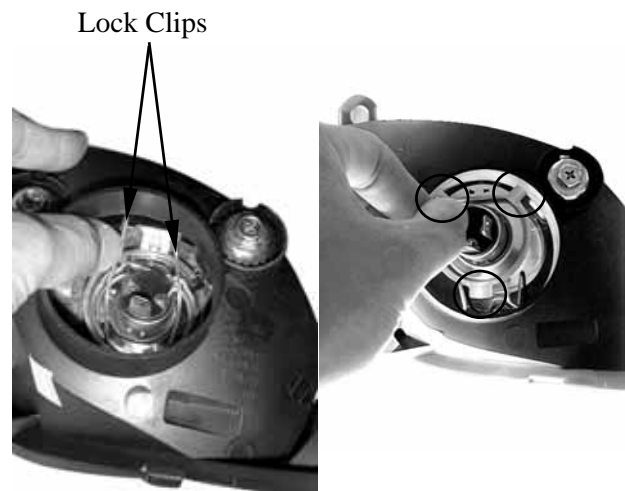

17. LIGHTS/ SWITCHES

POSITION LIGHT (MXU 150)

Remove the bulb socket by pulling it out.

Remove the bulb.

Install the bulb in the reverse order of removal



Bulb Socket

INSTRUMENTS (MX'er 150/125)

REMOVAL

Remove the two headlight attaching bolts.
Remove the headlight and disconnect the headlight wire coupler.

Remove the two headlight case attaching screws and disconnect the headlight.

Remove the light shell, rubber boot and bulb socket.

Check the bulb for damage and replace with a new one if necessary.

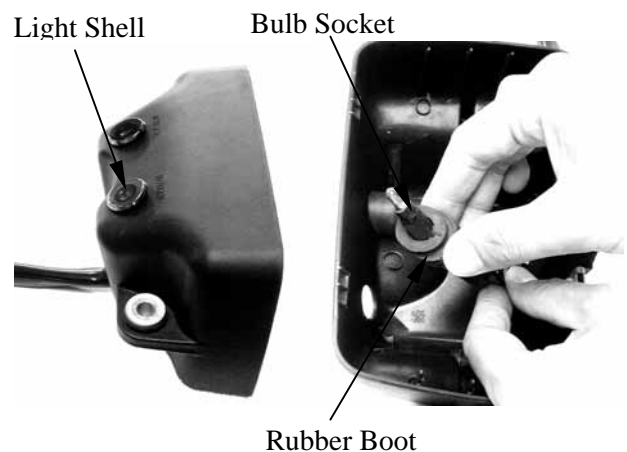

INSTALLATION

The installation sequence is the reverse of removal.

STOP LIGHT/TAILLIGHT

MX'er 150/125:

Remove the two taillight shell screws and the shell.



Taillight Shell Screws

17. LIGHTS/ SWITCHES

Remove the bulb and check the bulb for damage. Replace with a new one if necessary.

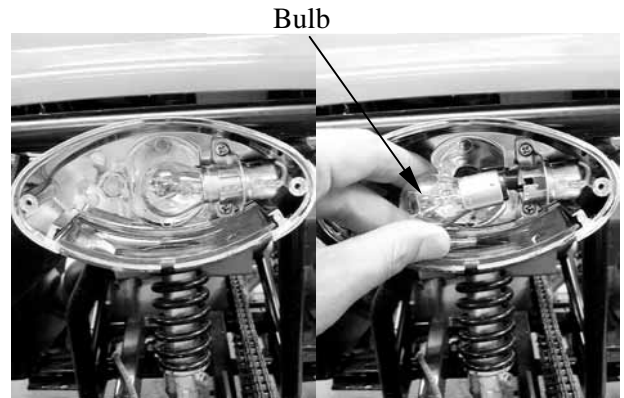

MXU 150:

Remove the bulb socket by turning it counterclockwise.
Remove the bulb.

Install the bulb in the reverse order of removal.

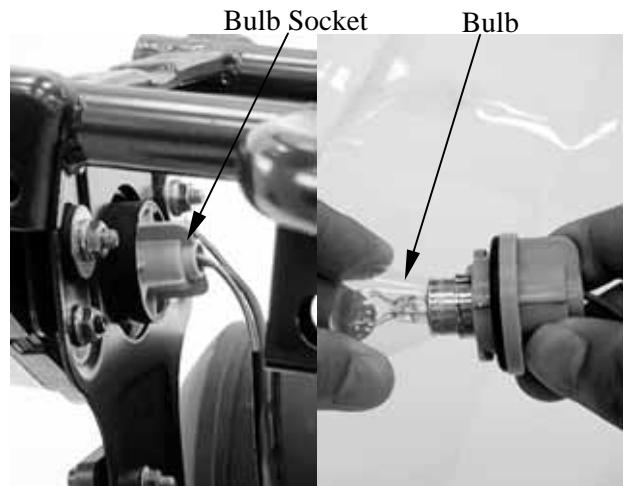

IGNITION SWITCH

MX'er 150/125:

Check for continuity between the wires indicated below.

Color Position	Black	Red	Black/ White	Green
OFF			○ — ○	
ON	○ — ○			



17. LIGHTS/ SWITCHES

MXU 150:

INSPECTION

Disconnect the ignition switch connectors. (Refer to the “HANDLEBAR COVER REMOVAL” section in chapter 2.)

Check for continuity between the switch side connector terminals in each switch position.

Continuity should exist between the color coded wires as right:

REPLACEMENT

Release the switch wire from the wire clips on the steering shaft holder frame pipe.

Remove the handlebar cover (see page 2-12).

Remove the ignition switch from the cover while pushing in the two stoppers.

Install a new ignition switch by aligning the locating tab with the groove in the cover.

Install the removed parts in the reverse order of removal.

COMB SW

	IG	E	BAT1	BAT2	PO
OFF	○	○			
ON			○	○	
PO			○	○	○
COLOR	B/W	G	R	B	BR

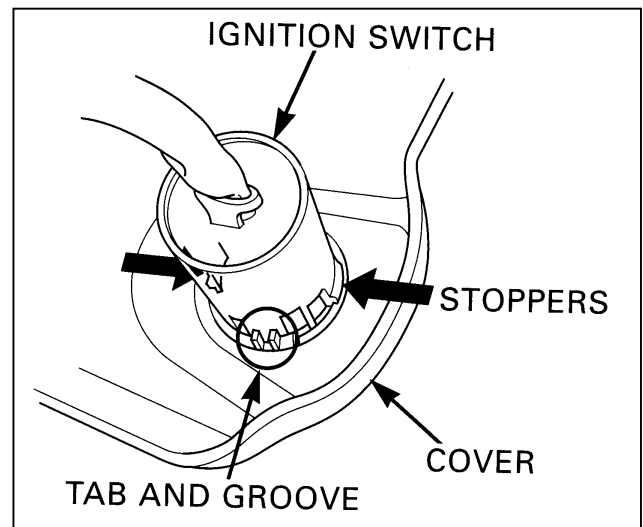

STOP SWITCH

Disconnect the front stop switch wire coupler.

Check for continuity between the front stop switch wires.

Brake lever applied: There is continuity.

Brake lever released: There is no continuity.



17. LIGHTS/ SWITCHES

HANDLEBAR SWITCH (MX'er 150/125)

STARTER BUTTON

Remove the center cover.
Disconnect the starter button yellow/brown and yellow/red wires.
Check for continuity between the black and yellow/red wires.

Color Position	Yellow/Brown	Yellow/Red
FREE		
PUSH	○	○

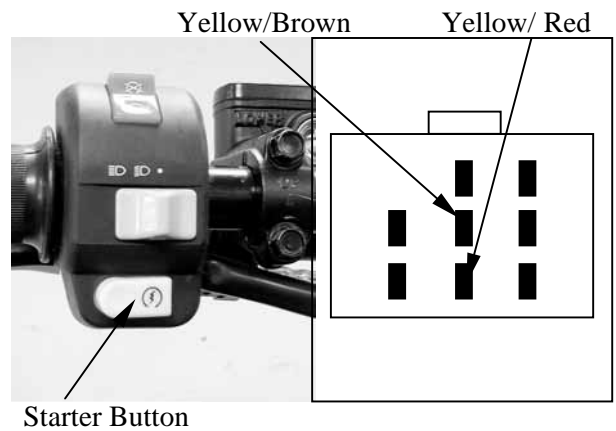

HEADLIGHT SWITCH

Remove the center cover.
Disconnect the headlight switch wire coupler. Check for continuity between the headlight switch wires.

Color Position	Black	Brown	White	Blue
•				
☰	○	○	○	
☷	○	○		○

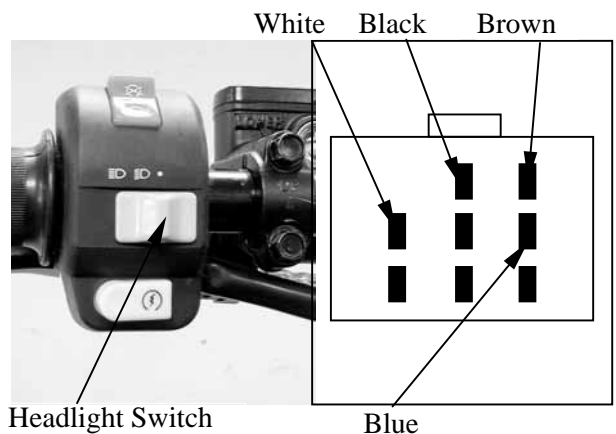

ENGINE STOP SWITCH

Remove the center cover.
Disconnect the headlight switch wire coupler. Check for continuity between the headlight switch wires.

Color Position	Green/Red	Green
⊗		
⊙	○	○

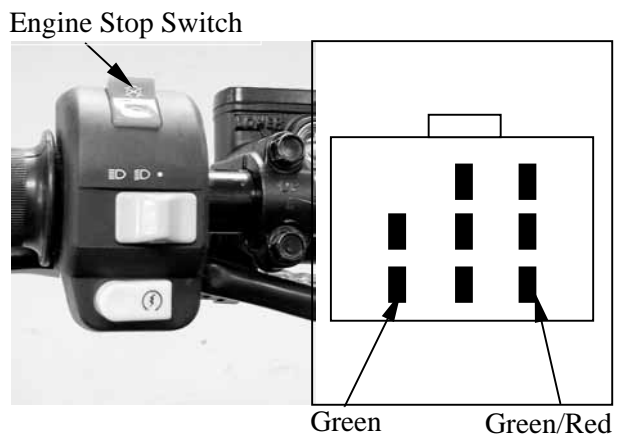

17. LIGHTS/ SWITCHES

HANDLEBAR SWITCH (MXU 150)

INSPECTION

Remove front center cover. (See page 2-12)

Disconnect the connectors.

Check for continuity between the switch side connector terminals in each switch position.

Continuity should exist between the color coded wires as next page:

KILL SW

	E	IG
COLOR	G	G/R

START SW

	ST	C
FREE		
PUSH		
COLOR	Y/R	Y/BR

DIMMER SW

	HL	LO	HI	PO
COLOR	B	W	L	BR

PASSING SW

	BAT	HI
FREE		
PUSH		
COLOR	B	L

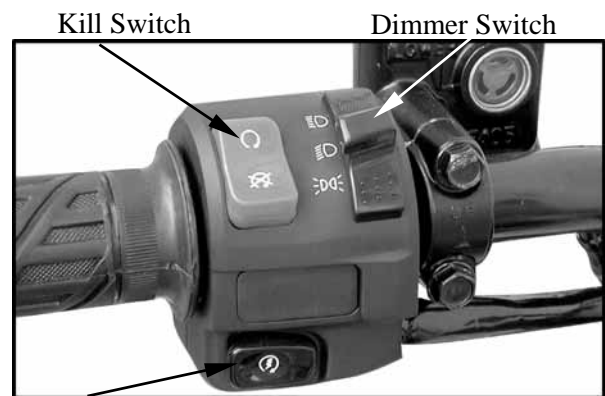

Start Switch

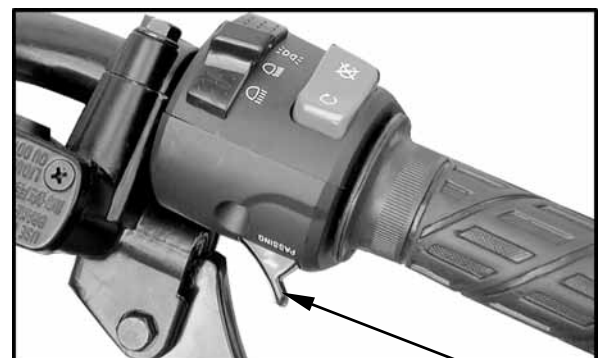

Pass Switch

17. LIGHTS/ SWITCHES

NEUTRAL/REVERSE SWITCHES

INSPECTION

Disconnect the neutral/reverse switch wire connector. (See page 6-2.)

Check for continuity between the switch side connector terminal and engine ground.

NEUTRAL SWITCH

There should be continuity with the transmission in neutral and no continuity with it in any gear except neutral.

REVERSE SWITCH

There should be continuity with the transmission in reverse and no continuity with it in any gear except reverse.

REPLACEMENT

Remove drive and driven pulley. (Refer to chapter 9)

Remove the two bolts and set plates.
Remove neutral/reverse switch.

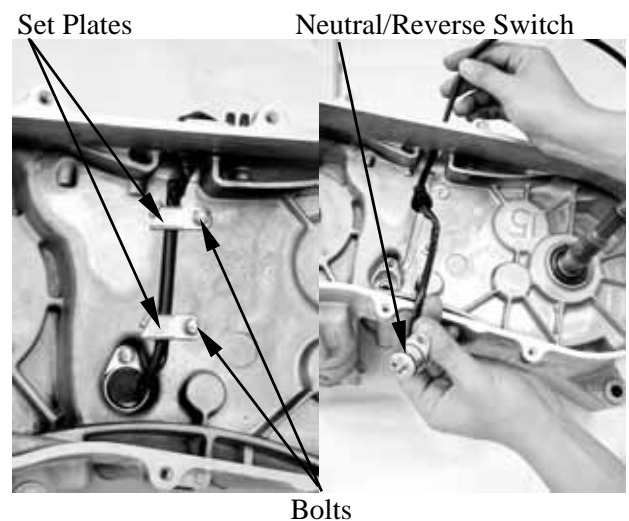

Install a new switch with a new O-ring (apply engine oil to O-ring).

* Make sure that the lever on the neutral/reverse switch correctly engages with the locating slot on the shift shaft.

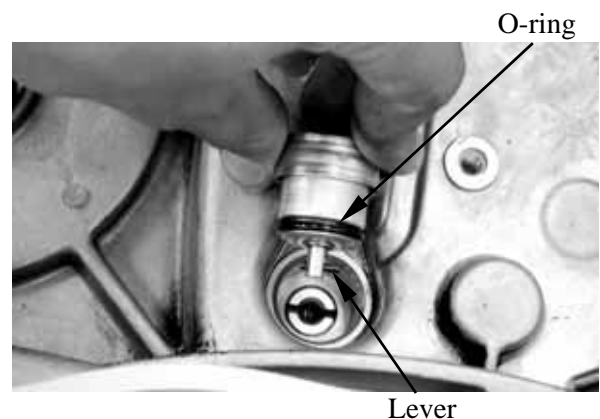

ONLY ATV ON ROAD AVAILABLE

18

BRAKE PEDAL ADJUSTMENT -----	18- 1
INSTRUMENT (MX'er 150/125) -----	18- 2
INDICATOR LIGHT (MX'er 150/125) -----	18- 2
TURN SIGNAL LIGHT (MXU 150) -----	18- 3
HORN -----	18- 4
HAZARD SWITCH (MX'er 150/125)-----	18- 4
HANDLEBAR SWITCH (MXU 150) -----	18- 4

18. ONLY ATV ON ROAD AVAILABLE

BRAKE PEDAL ADJUSTMENT

The brake pedal free play should be adjusted to 10~20 mm (0.4~0.8 in) at the brake pedal pivot. If the free play is incorrect, adjust as Follows:

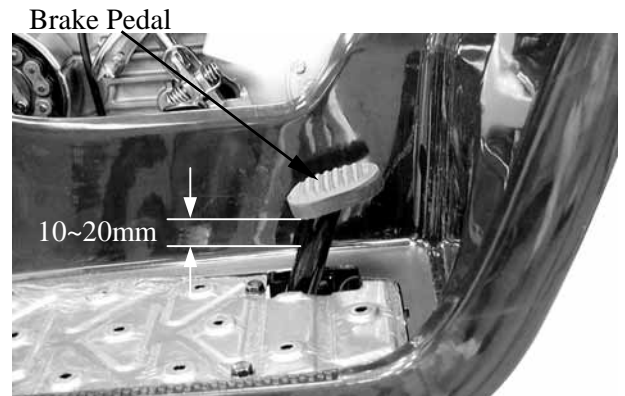

Keep front brake lever free play at 10~20 mm (0.4~0.8 in). (Refer to page 3-9)

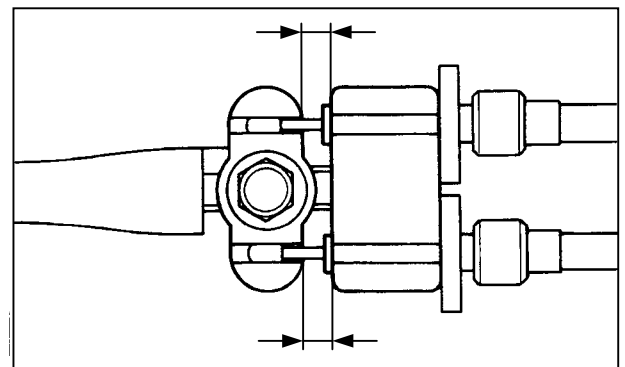

Loosen the lock nut.
Turn the adjusting bolt until the front lower brake cable is tensed.
Apply the front brake lever and check front brake cam lever to make sure that the brake does not drag after adjusting.
Tighten the lock nut.

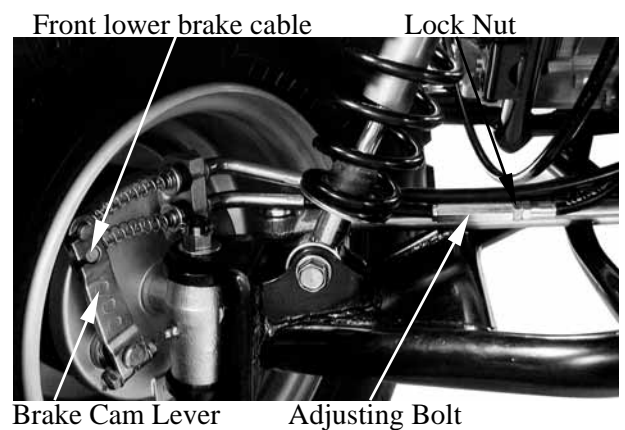

Turn the adjusting nut on the brake cam lever to decrease play or increase play.
Turn the adjusting nut until specified free play is obtained.

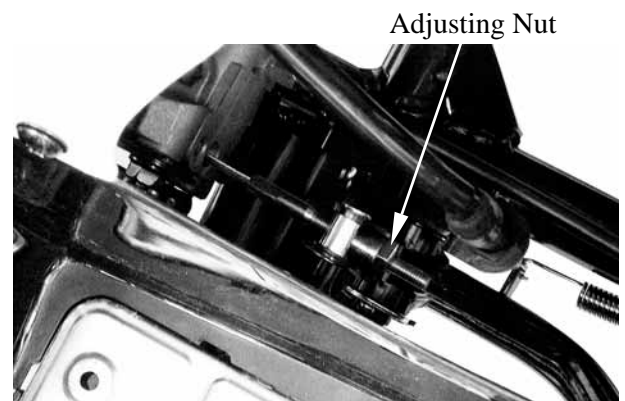

18. ONLY ATV ON ROAD AVAILABLE

INSTRUMENT (MX'er 150/125)

REMOVAL

Remove the two instrument attaching screws.

Disconnect the instrument connectors and remove the instrument.



Screws

SENSOR WHEEL

If the sensor is lost or worn, the speed will be not calculated on the instrument.

Speed Wheel

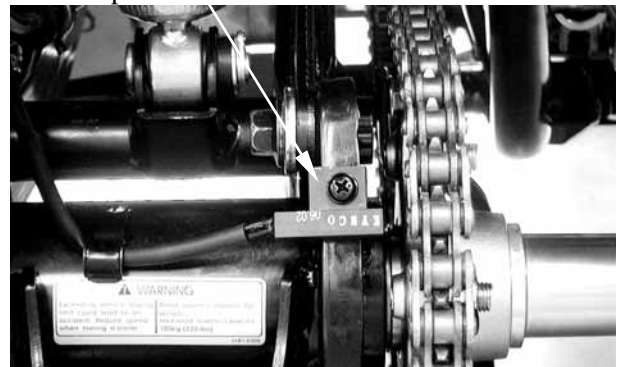

INDICATOR LIGHT (MX'er 150/125)

REMOVAL

Remove the screw and disconnect the cover of the ignition switch.

Screw



Remove the bulb socket and bulb.

Check the bulb for damage and replace with a new one if necessary.

INSTALLATION

The installation sequence is the reverse of removal.

Bulb Socket

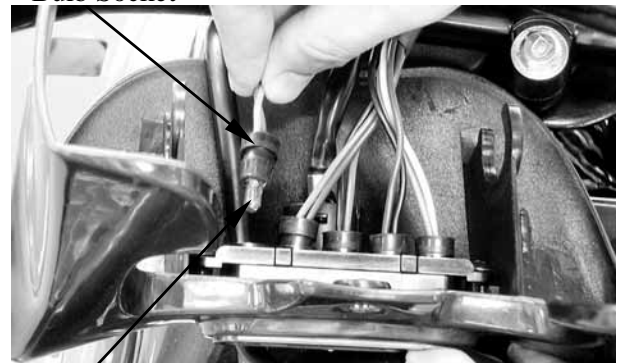

Bulb

18. ONLY ATV ON ROAD AVAILABLE

TURN SIGNAL LIGHT (MXU 150)

FRONT

Remove the rubber boot from the turn signal light case.
Remove the bulb socket by turning it counterclockwise.

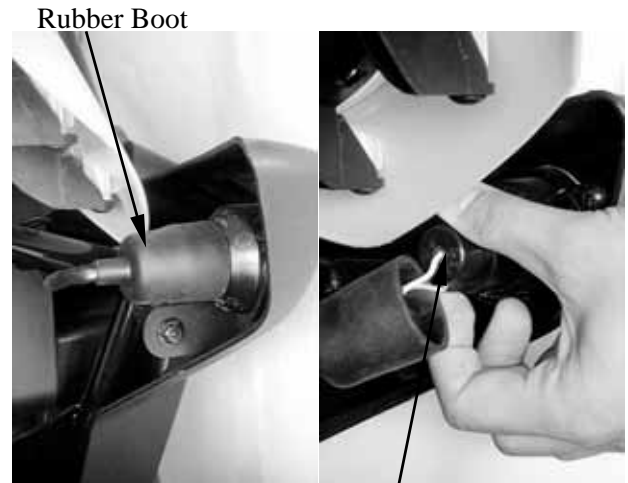

Bulb Socket

Remove the bulb.

Install the bulb in the reverse order of removal.

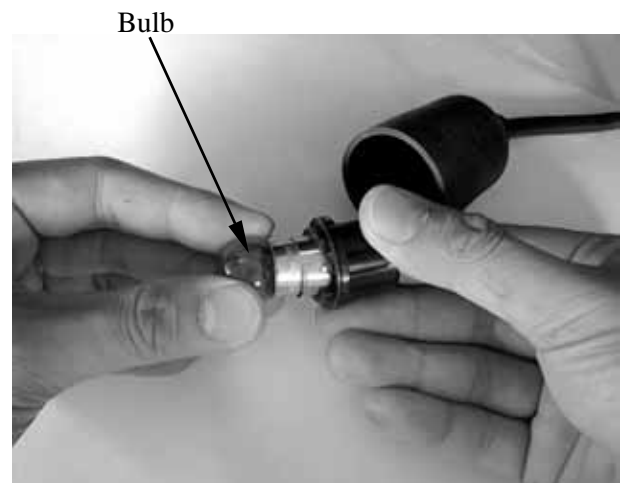

Bulb

REAR

Remove the bulb socket by turning it counterclockwise.
Remove the bulb.

Install the bulb in the reverse order of removal.

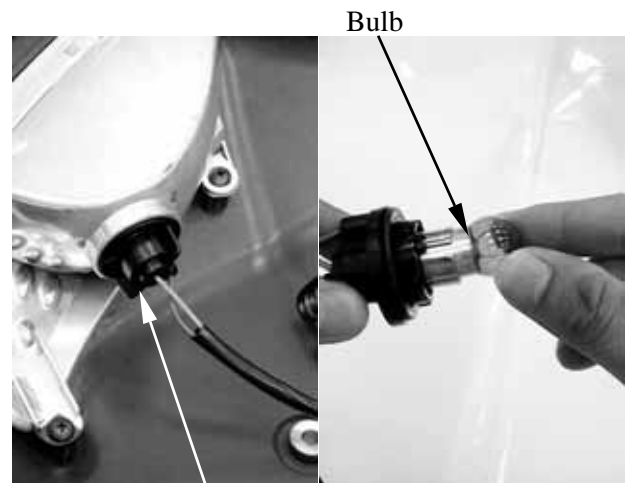

Bulb Socket

18. ONLY ATV ON ROAD AVAILABLE

HORN

REMOVAL

Disconnect the horn switch wire.
Remove the bolt and remove horn.

INSTALLATION

The installation sequence is the reverse of removal.



Bolt

Horn Switch wire

HAZARD SWITCH (MX'er 150/125)

Check for continuity between the wires indicated below.

Color Position	Yellow /Black	Black
	—	—



Hazard Switch

HANDLEBAR SWITCH (MXU 150)

HORN SW

	HO	BAT
FREE		
PUSH	○	○
COLOR	LG	B

WINKER SW

	R	L	WR
L		○	○
R	○	—	○
COLOR	SB	O	GR

START SW

	ST	C
FREE		
PUSH	○	○
COLOR	Y/R	Y/BR

DIMMER SW

	PO	LO	HI
	○		
	○	○	
	○	—	○
COLOR	B	W	L

HAZARD SW

	BAT	HA
	○	○
●		
COLOR	R	Y/B

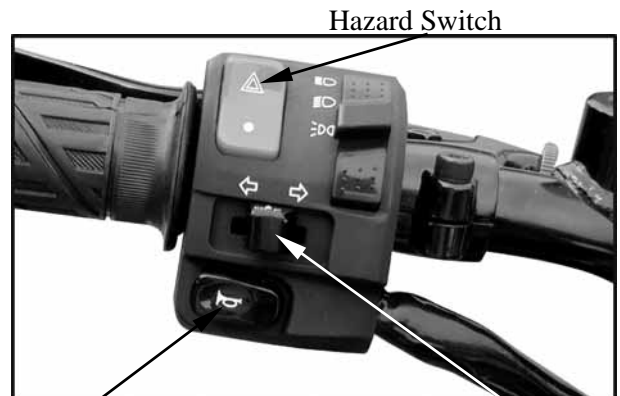

Hazard Switch

Horn Switch

Winker Switch



Light Switch

Start Switch